

WOODWAY USA, Inc.

WOODWAY®

Curve LTG Treadmill

Owner's Manual



Copyright 2022 ©
WOODWAY® USA, Inc. All rights reserved.
No portion of this content may be reproduced in any form without permission from the publisher, except as permitted by U.S. copyright law.

OM-011-EN-R2

WOODWAY® History

WOODWAY's ® history began in Germany in 1974. Willi Schoenberger, a technical director in charge of planning a fitness center, noticed that the most important piece of equipment, the treadmill, did not meet the most important requirements: a mechanically sound machine that is designed to meet human needs.

He envisioned a comfortable surface that did not interfere with the natural biomechanics of running or walking. Also, he wanted to design a transportation system which eliminated the friction associated with the conventional (conveyor belt) treadmills. After intensive research, and trial and error (and in cooperation with the Deutsche Sporthochschule in Koln, Germany), Willi developed and patented a very unique and revolutionary treadmill design.

In 1975, WOODWAY® GMBH was founded in Weil am Rhein, Germany. The name "WOODWAY"® is derived from the German "wald weg" or "way of the woods" – the feel of running on a soft pine needle covered path in the forest.

In 1983, a manufacturing license was awarded to Sakai Medical, for the use of WOODWAY® technology in the Japanese marketplace.

In 1988, a U.S. license was granted to a small, but well-established manufacturing company in Waukesha, Wisconsin. WOODWAY® USA was formed when the U.S. incarnation of the WOODWAY® was developed and completed in 1990. WOODWAY® USA is very proud to be the primary manufacturer of WOODWAY® Treadmills worldwide, exporting treadmills each month to Germany and Japan for international distribution, in addition to serving our domestic customers and clients.

Today, WOODWAY's ® design and manufacturing facilities in the United States, Germany and Japan make WOODWAY® the largest specialized treadmill manufacturer in the world. Constant enhancements in quality, design and function are shared and implemented by all three WOODWAY® manufacturers.

See "**Contact Information**" on **page 16** for WOODWAY® Customer Service information.

Table Of Contents

1. Introduction

- 1.1 How To Use This Manual 4

2. Important Safety Instructions

- 2.1 Safety 5
- 2.2 Hazard Signal Words.....5
- 2.3 General Safety..... 6

3. Installation

- 3.1 Optional Tools..... 12
- 3.2 Hardware/Tools Included 12
- 3.3 Unpacking 13
- 3.4 Assembly 15
- 3.5 Adjusting Treadmill Feet..... 23

1 Introduction

1.1 How To Use This Manual (READ THIS FIRST)

This manual is published in PDF format. It is designed for printing.

This owner's manual supports equipment installation and set-up. Observe all safety procedures. See "Hazard Signal Words" on page 6. Also see "General Safety" on page 7 for general safety considerations.



Read the manual before using the equipment or engaging in any adjustment procedures.

2 Important Safety Instructions

2.1 Safety

- Read all instructions before using the Curve LTG.
- Save these instructions.
- **WARNING:** Failure to leave ample clearance around the Curve LTG could cause you to be trapped between the Curve LTG and a wall if you fall, resulting in burns or other serious injury from the moving slatbelt. Allow a minimum clearance of 18 inches (46cm) on each side of the Curve LTG. Allow a minimum clearance of 6.3 feet (191cm) at the rear of the Curve LTG. (FIG. 2.3.1)

2.2 Hazard Signal Words

Set-up and adjusting the equipment can be hazardous. Many (but not all) such actions are identified in this manual. Warnings associated with hazards are found throughout this manual. The main signal words are DANGER, WARNING, and CAUTION.



DANGER

Strong Potential For Serious Injury Or Death

Used in situations where there is a hazard that WILL cause serious injury or death if not avoided.



WARNING

Potential For Serious Injury Or Death

Used in situations where there is a hazard that COULD cause serious injury or death if not avoided.



CAUTION

Potential For Minor Injury Or Equipment Damage

Used in situations where there is a hazard that COULD cause injury or equipment damage if not avoided.

2.3 General Safety

The equipment supported by this manual is safe and reliable when operated and maintained properly. Observe all precautionary statements and safety instructions. For safety instruction explanations. **"Hazard Signal Words" on page 6**



CAUTION

Servicing By Unqualified Technicians Can Lead To Injury Or Death

Serviceable only by qualified service technicians. A qualified service technician is a person who has successfully completed the WOODWAY® factory authorized service school or has equivalent training and experience.



WARNING

Injury Hazard

Follow all listed service precautions.

Precautions To Observe:

- Set up and operate the equipment on a solid, level surface.
- Use the equipment only for its intended purpose as described in this Owner's Manual. Do not use attachments not specified by the manufacturer.
- Never clean or service while connected to electrical power source.
- Do not operate the equipment out doors.
- Keep all loose clothing and towels away from the running surface.
- Prevent shoelaces from extending beyond the bottom of shoes.
- Keep the area behind equipment clear and at least 6-1/2 ft (2 m) from walls or furniture.
- Keep hands away from all moving parts.
- Inspect the equipment for worn or loose components prior to use. Tighten or replace any worn or loose components.
- Read, understand, and test all emergency stop procedures.
- Equipment capacity is rated for 350 lbs. (158.8 kg).
- Use caution when mounting and dismounting the equipment. Use the handrails.
- Wear proper athletic shoes with rubber or high-traction soles. Do not use shoes with heels or leather soles. Ensure no stones are embedded in the profile of the soles.
- Regularly inspect the equipment for damage and/or wear. Repair immediately as needed. Use only manufacturer supplied or approved components.
- Do not attempt service without contacting WOODWAY® Service.
- Always keep the running surface clean and clear of obstructions.

 **CAUTION**

Improper Operation Causes Accidents

Using the equipment for other than its intended purpose can cause accidents or equipment damage.

- These instructions must be completely read and understood before servicing the equipment.
- Operating Instructions in the Owner’s Manual must be completely read and understood before operating the equipment for operational testing and functional diagnosis.
- Keep this manual accessible for all users.

Note: WOODWAY® is not liable for accidents, equipment damage, or consequences related to miss-use or failure to follow the operating or servicing instructions. WOODWAY® reserves the right to make technical changes in the context of product improvement without prior notice. Illustrations are for basic understanding only and may differ from the actual design. WOODWAY® accepts no liability for accidents, equipment damage, or personal injury caused by using third-party accessories.

Table 1: Storage And Transportation Requirements (All Models)

Parameter	Value
Temperature	- 22 to 158° F (-30 to 70° C)
Relative Humidity	15 to 85% (non-condensing)

 **CAUTION**

Moisture Hazard

Store the equipment only in closed, dry rooms. Direct contact with moisture (rain, fog, etc.) can cause serious damage to the electronics. Damaged electronics can negatively affect safe operation.

Note: Curve LTG treadmills have no drive motor. Electrical power requirements are minimal. The display system is powered by an enclosed generator.

Note: This equipment is not intended for use in damp locations.

2.3.1 Equipment Specifications

Table 2: Curve LTG Specifications

Running Surface	16.6 in X 61.8 in (42.2 cm X 157.0 cm)
Slats	60 Rubber on plastic composite
Drive System	98 roller bearings and 12 guide rollers.
Overall Dimensions	33 in W X 74 in L X 72 in H (84 x 189 x 184 cm)
Mass	296.8 lbs. (134.6 kg)
Standard Display (Self Powered)	Standard Display Board: shows the parameters of Speed, Time, Energy, Group/Circuit Mode, Lap, Heart Rate (when paired w/smart device)
Power Requirements	NA
Variable Resistance	NA

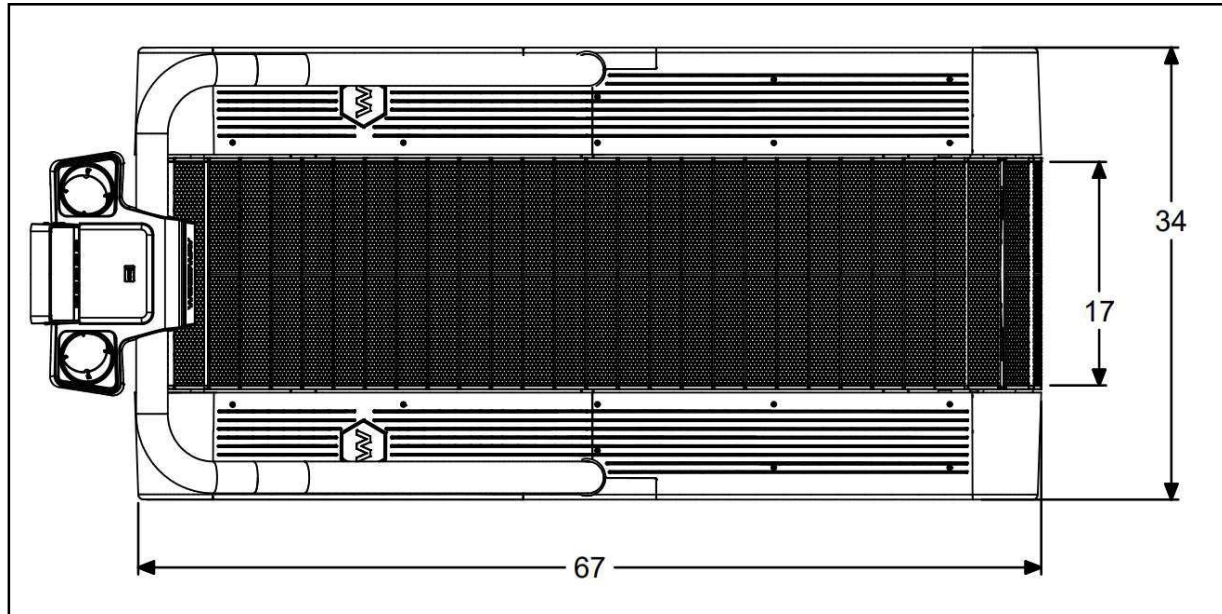

FIG. 1 Curve LTG Dimensions

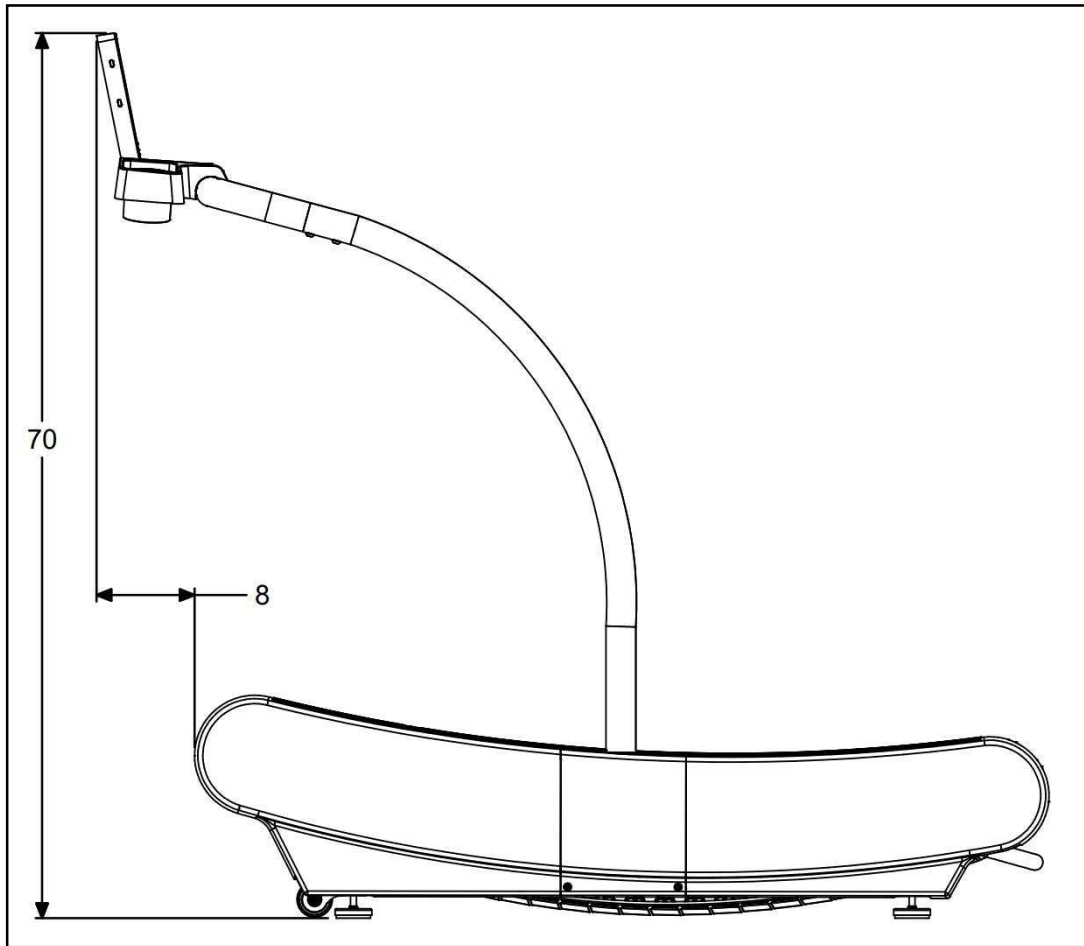

FIG. 2 Curve LTG Dimensions

2.3.2 Customer Service And Nameplate Information

Table 3: Contact Information

USA	Europe
WOODWAY® USA, Inc. W229N591 Foster Ct. Waukesha. WI 53186 USA	WOODWAY® GmbH Steinackerstr, 20 79576 Weil am Rhein Germany
Tel: 1(262) 548-6235	Tel: +49 (0) 7621-940-999-0
Fax: 1(262) 522-6235	Fax: +49 (0) 7621-940-999-40
Email: service@woodway.com	Email: service@woodway.de
Web: woodway.com	Web: woodway.de

Each product receives a serial number during manufacturing. This serial number has an alphanumeric code with 7-8 characters or a numeric code with 9 digits. The serial number is on the name plate, mounted on the rear of the display or on the left front of the frame.

Specific functions are stated on the nameplate and on the delivery note. Refer to the nameplate data during service calls.

3 Installation

This section describes the proper procedure for moving the equipment and positioning it into the final location. Follow the process precisely as presented. The process is incomplete until equipment is ready for installation, post-installation testing, and commissioning.

CAUTION

Condensation Hazard

Bringing cold equipment into a warm environment can cause condensation. This moisture can damage the electronics if energized. Allow the equipment to rest at room temperature for at least three hours to acclimate to the warm environment. Do not energize until the equipment is dry.

Note: WOODWAY® is not responsible for damages and missing parts if not recorded on the delivery note upon delivery. Report damage or defects to the carrier and to the responsible WOODWAY® dealer immediately. ["Contact Information" on page 16.](#)

WARNING

Toppling Equipment Injury Hazard

Improper handling can result in losing control. If the equipment topples, injury or damage can result.

- Carry the equipment using at least four persons.
- Carry the equipment as low to the floor as practical.
- Only properly trained workers can safely use forklifts, pallet jacks, or similar devices.
- Never lift by side handles, or computer console.

3.1 Optional Tools

- #2 Phillips Screwdriver
- 16mm Open End Wrench

3.2 Hardware/Tools Included

- Hardware and Tools Supplied on Blister Pack

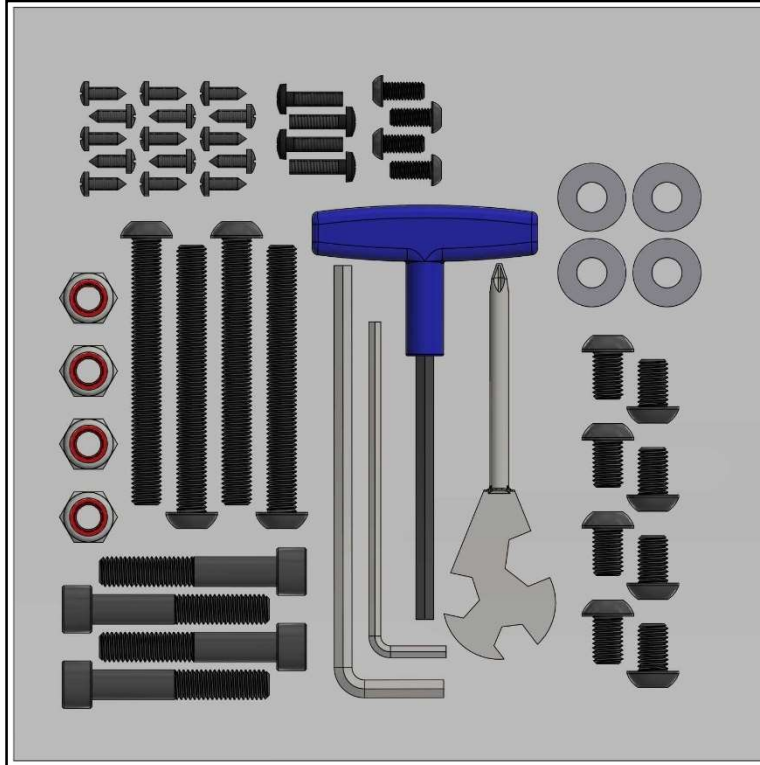

FIG. 3 Blister Pack

3.3 Unpacking

- Move boxed unit to room where it will be used. The packaged Curve LTG is very heavy and weighs 317 lbs (144 kg) packaged.
- **WARNING:** To avoid injury, use caution when moving and lifting the Curve LTG during unpacking and assembly.
- Locate where the Curve LTG will be used to provide space as shown.

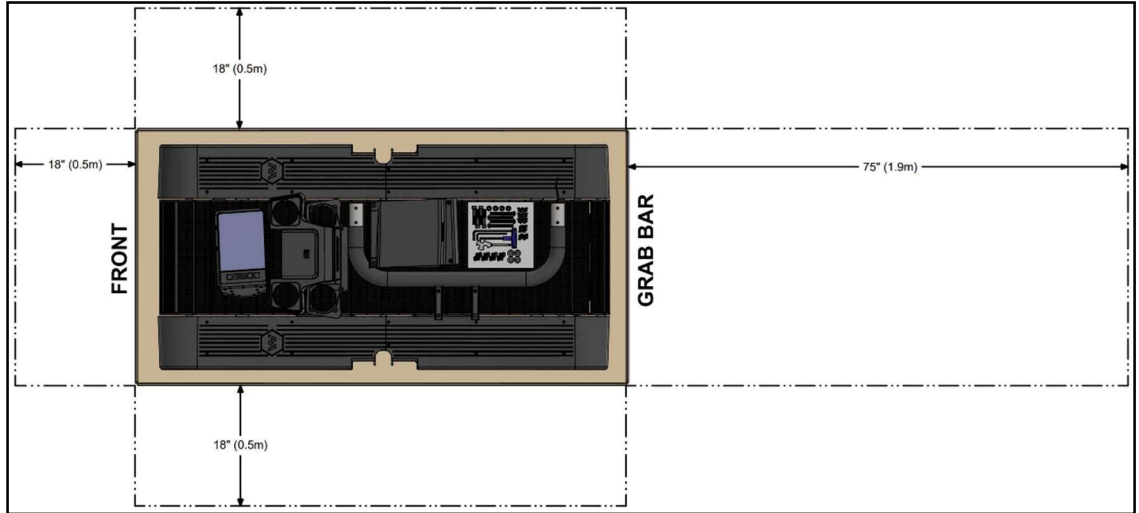

FIG. 4 Clearance

- Cut the straps, and take off the top of the box.

FIG. 5 Top Box Removal



- Remove any wood bracing and packing foam from inside the box.
- The display and enclosure tray will be in a smaller box positioned on top of the Curve LTG base.
- Cut open the bottom shipping box as shown.

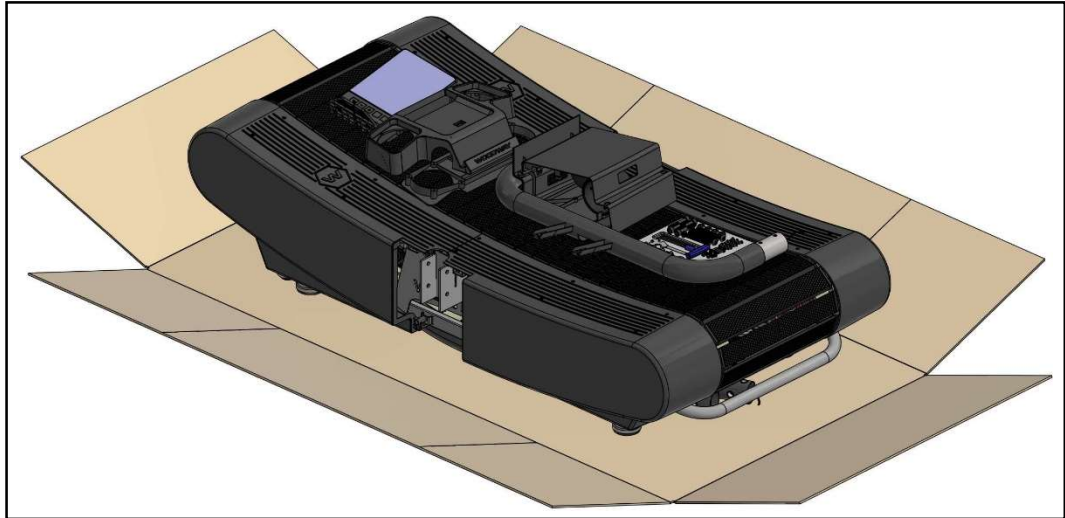

FIG. 6 Bottom Box

- Move the components from the top of the base, and the handrails packed below the base to an area to the side of the base.

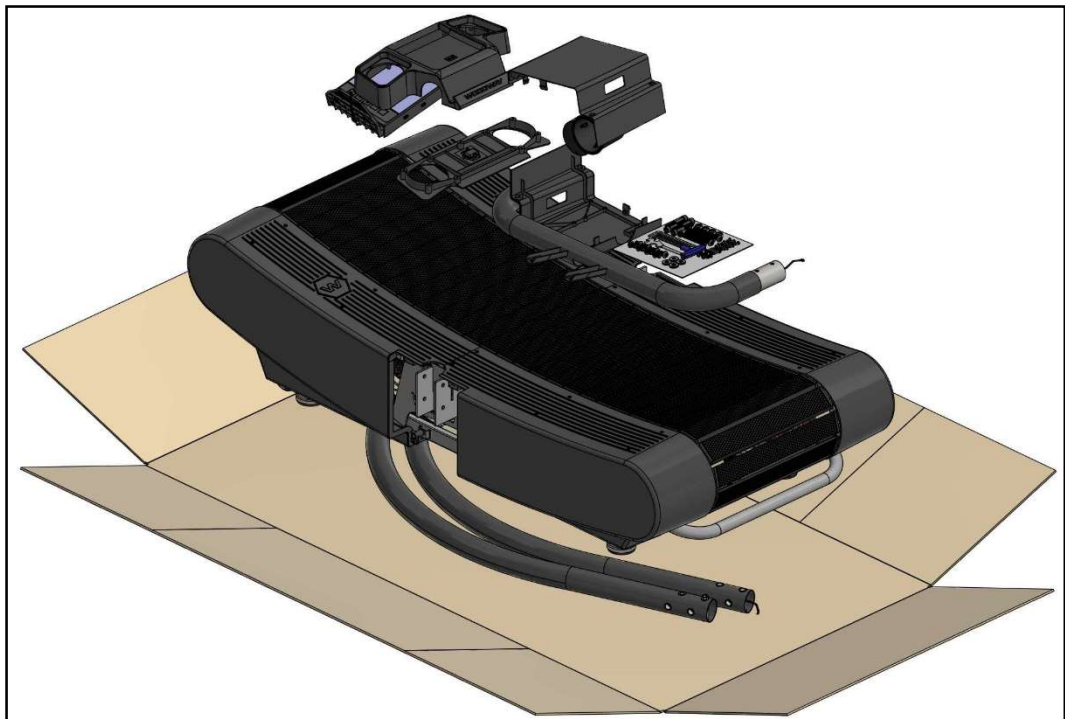

FIG. 7 Box Contents

- Remove the Curve LTG base from bottom box and place it where it will be used as determined in step one. Two people need to utilize the grab bar to lift the aft side of the Curve LTG and use the front caster wheels to position the Curve LTG accordingly.

3.4 Assembly

- Assemble the display, mount plate, and enclosure tray.



FIG. 8 Display Assembly



FIG. 9 (Assembled)

- Assemble display/tray to the horseshoe portion of the handrail.

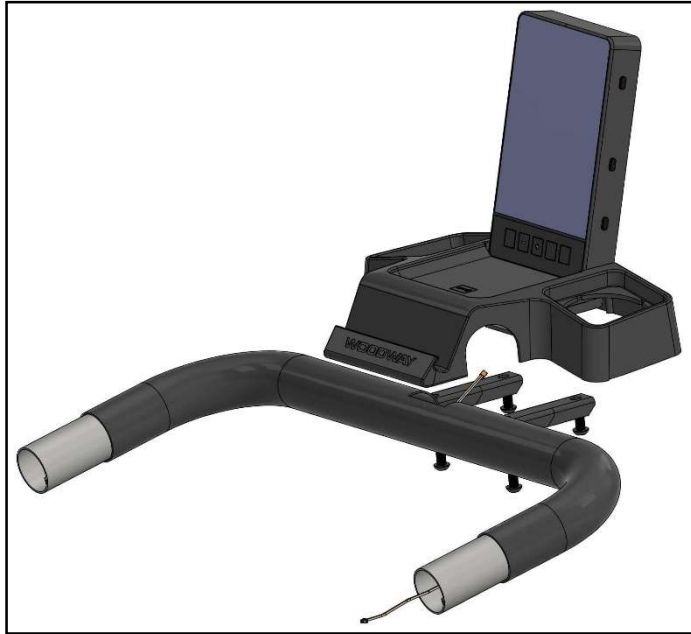

FIG. 10 Display to Horseshoe



FIG. 11 (Assembled)

- Connect the wires from the horseshoe assembly to the wires from the display assembly and stow the extra length of wire.
- Set to the side the assembled display/tray and handrail.

- Position the handrail with the wire connection to the righthand side of the base, and the handrail without any wires to the lefthand side of the base.



FIG. 12 Handrails to Base

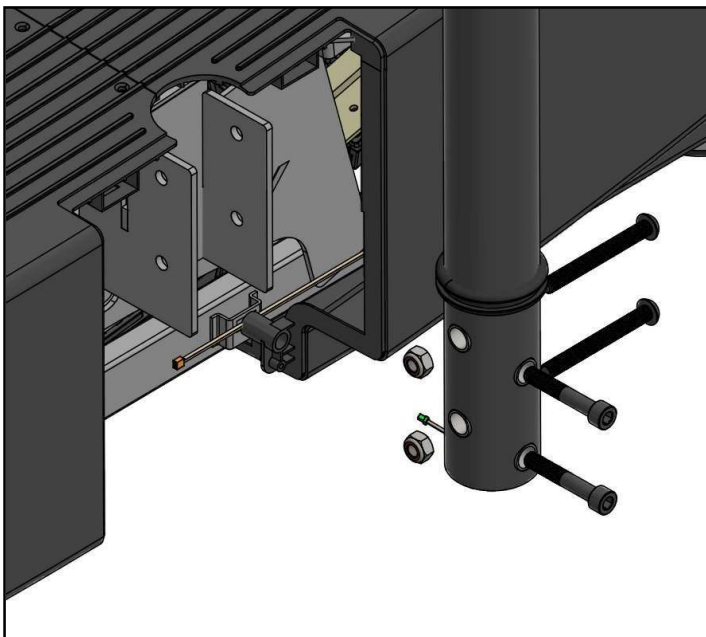

FIG. 13 Handrails to Base

- Mount the LH and RH handrails to the base with the hardware shown.



FIG. 14 Mounting Handrails

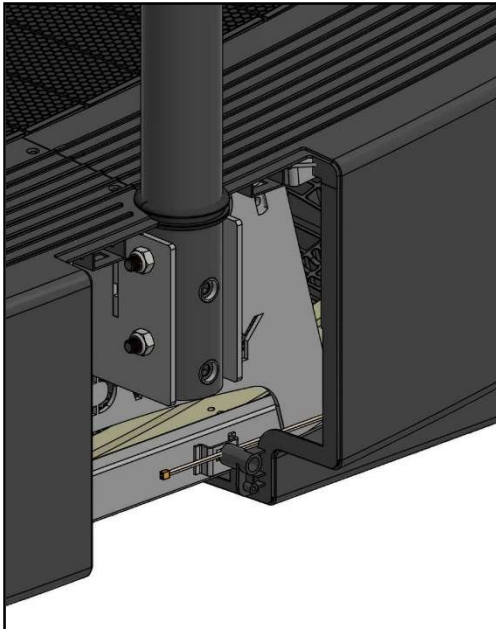

FIG. 15

- Connect the wires from the bottom of the RH handrail to the base frame wires. Use the twist-tie used in packaging to wrap and stow the extra length of wire to the base frame.
- Do not tighten the hardware yet. This hardware be tightened after the display assembly is installed.

- Loosely insert the LH side of the display/tray and handrail (horseshoe) assembly into the top end of the LH handrail.



FIG. 16 Horseshoe to Handrails

- Connect the wires from the horseshoe to the wires from the RH handrail.

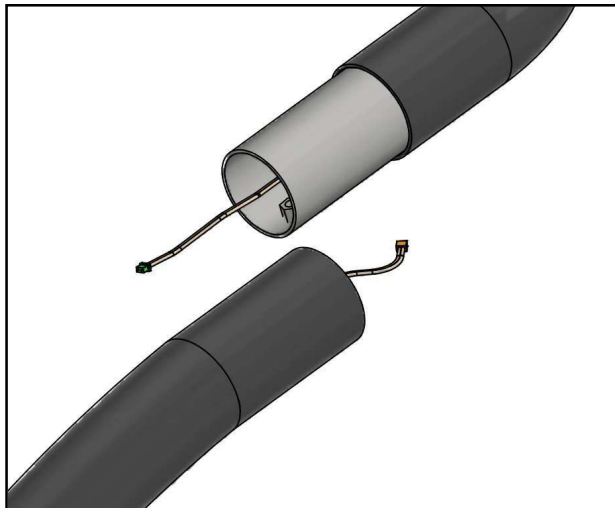

FIG. 17

- Once the two wires are connected, push the extra length of the connected wires into the RH handrail.
- Insert the RH side of the horseshoe into the top end of the RH handrail. To completely insert the horseshoe into the LH and RH handrails you may need to push several times on the LH, then the RH side of the horseshoe until the horseshoe is completely inserted into the handrails.



FIG. 18 Handrails and Hardware

- Insert and tighten the hardware shown, then tighten the hardware at the bottom of the LH and RH handrails.



FIG. 19 Hardware Installed

- Insert the cup holders into the top of the display tray. Install tray bottom cover with hardware.



FIG. 20 Display Enclosure



FIG. 21 (Assembled)

- Install the remaining two side cover panels.

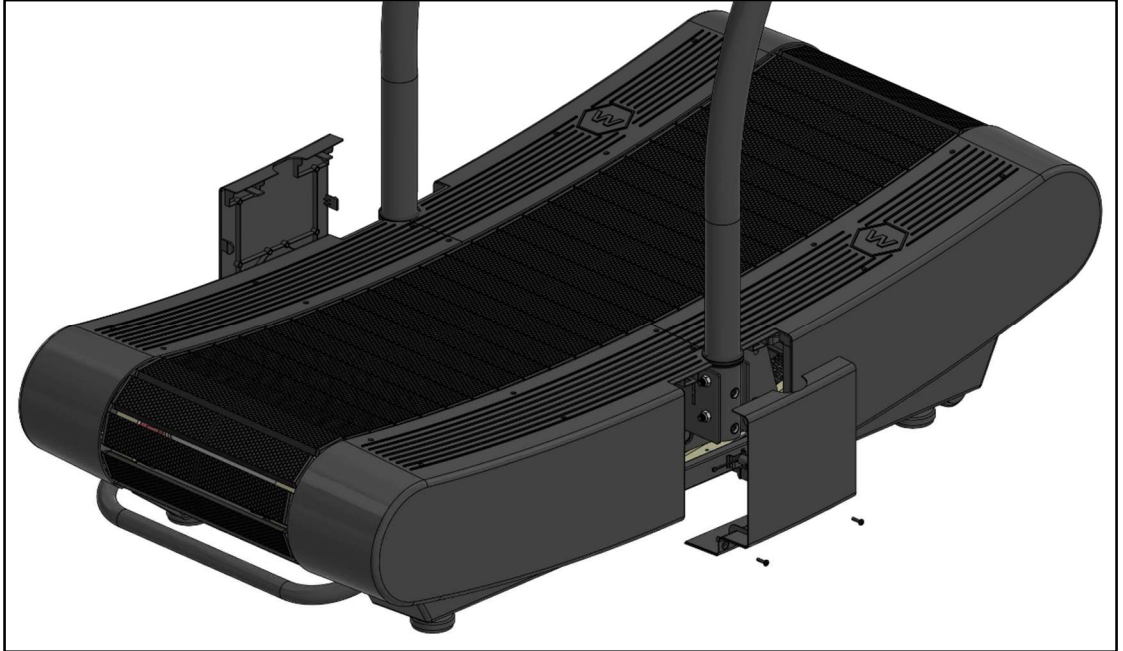

FIG. 22 Side Covers



FIG. 23 (Assembled)

- Adjust grommets as necessary during side panel installation.

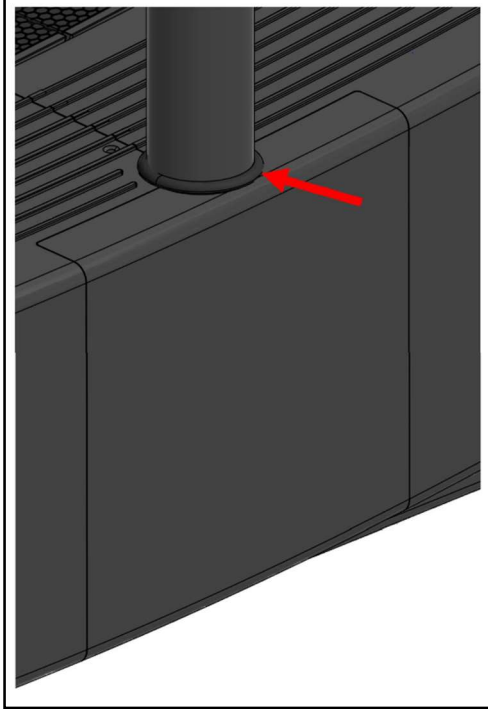

FIG. 24 Grommets

3.5 Adjusting Treadmill Feet

- Adjust the front feet down, one at a time, to raise the caster wheels just off the floor surface. When the front feet are adjusted to the proper position, tighten the locking nuts to the frame.

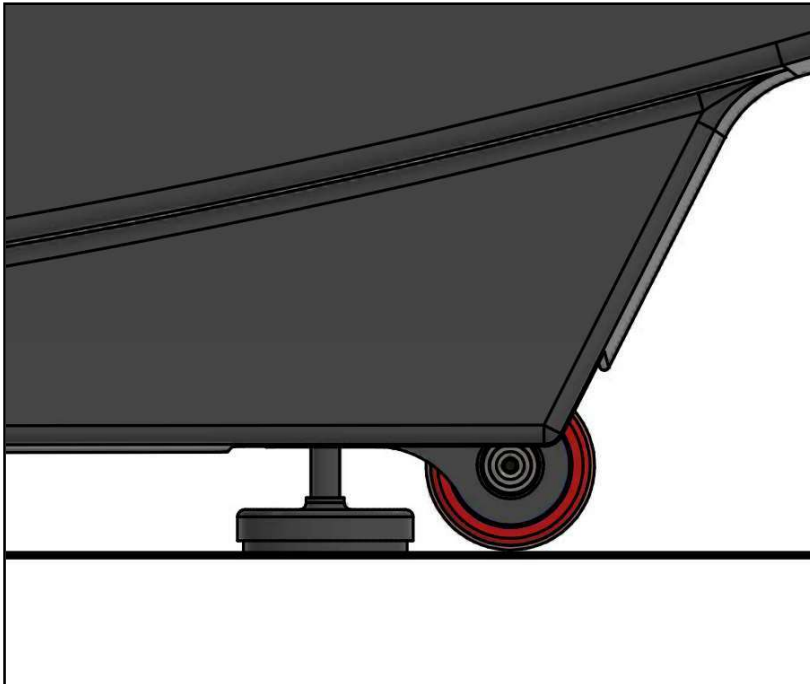

FIG. 25 Adjusting Front Feet

- Adjust the aft feet down, one at a time, until the bottom of the side cover panels are parallel to the floor. When the aft feet are adjusted to the proper position, tighten the locking nuts to the frame.

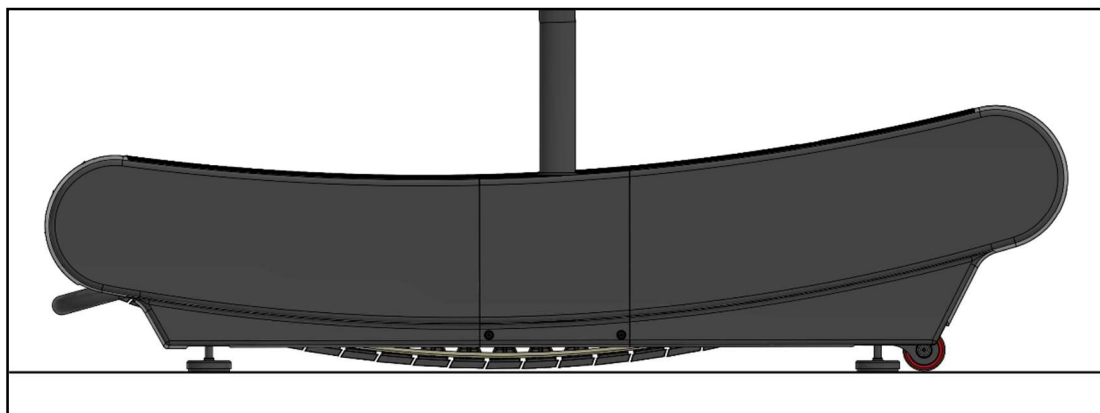

FIG. 26 Adjusting Aft Feet

- Check to be sure that the caster wheels are still raised just off the floor surface. If not, readjust the feet as in the previous steps.
- This will be the treadmill position starting point.
- When walking or jogging on the Curve LTG take notice of your position on the slatbelt relative to the handrails. If you feel that your position while using the Curve LTG is too far aft, the aft feet can be adjusted as noted in the previous steps to raise the aft end of the Curve LTG. When ever adjusting the feet positions, always make very small adjustments, tighten the locking nuts to the frame, and check to make sure that the front caster wheels are still raised just off the floor surface.

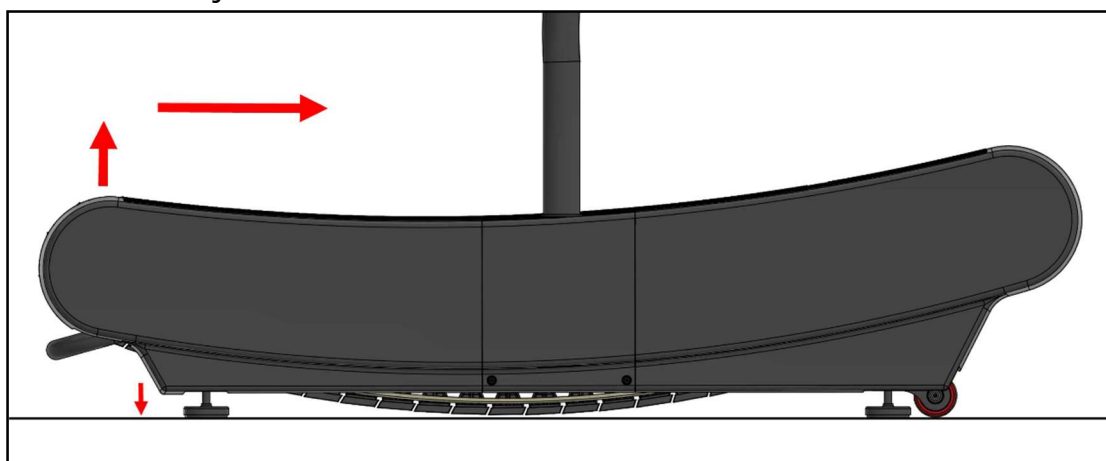

FIG. 27 Adjusting User Position

- **WARNING:** Failure to adhere to the above adjustment steps could create a hazard for the user.