

# ROGUE®

# FM-6 FUNCTIONAL TRAINER

## WEIGHT STACK OPTION

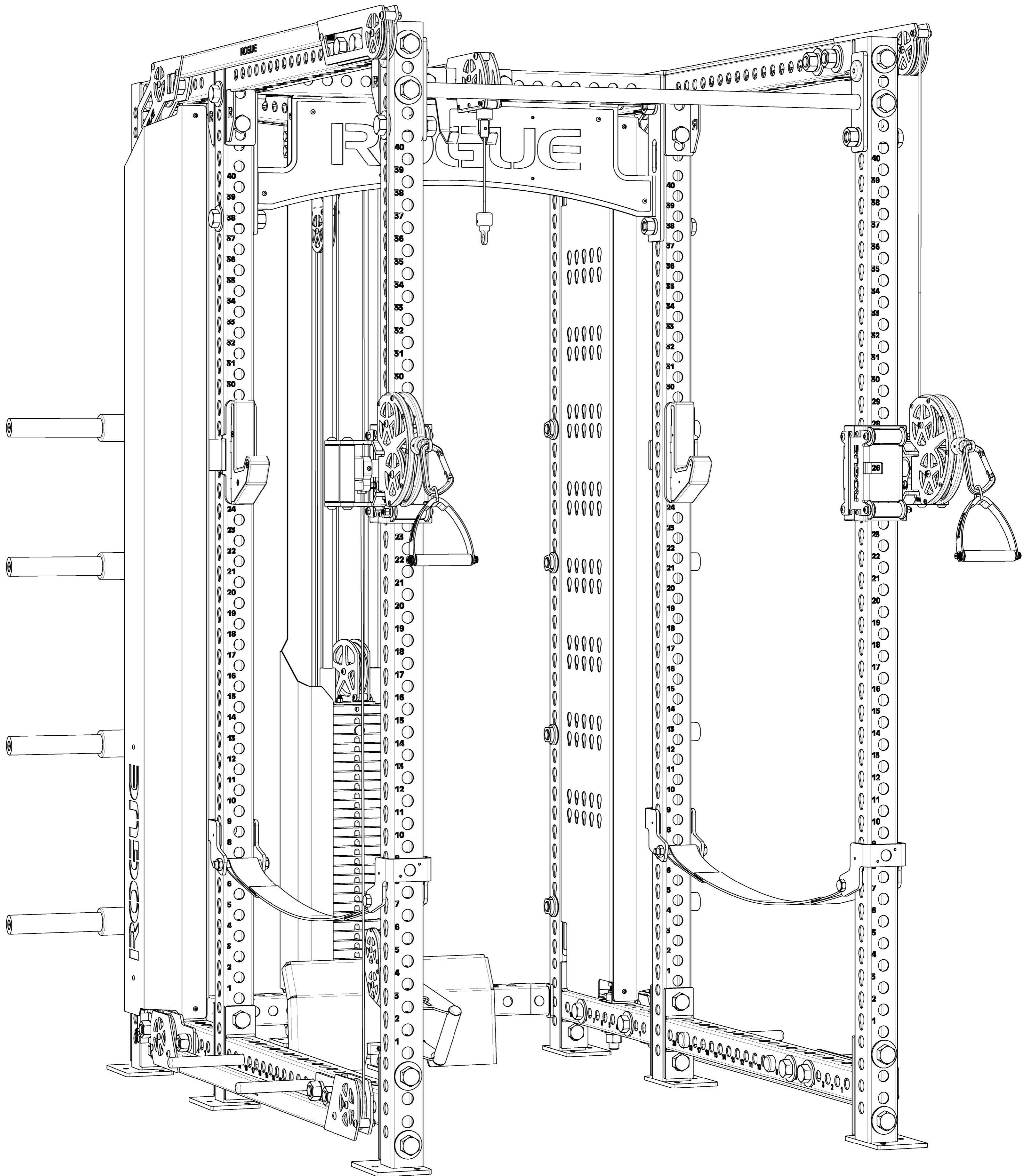

### **⚠ IMPORTANT SAFETY INFORMATION**

#### **DISCLAIMER:**

Resistance training, gymnastics training, and activities at height are potentially dangerous and may lead to severe injury or even death. Use common sense when training, obtain instruction in the proper execution of movements, and understand your limitations. This equipment must only be used by competent and responsible persons. Obtaining instruction in appropriate techniques and methods of use is your own responsibility. You assume all risks and responsibilities for all damage, injury or death which may occur during or following incorrect use of this equipment in any matter whatsoever. Rogue Fitness bears no liability beyond the replacement value of the equipment in question.

#### **WARNING:**

**THIS RACK MUST BE BOLTED TO THE FLOOR BEFORE USE. MINIMUM TWO PEOPLE REQUIRED FOR SAFE ASSEMBLY. MISUSE OF THIS RACK CAN RESULT IN SEVERE INJURY.**

Both Rogue Fitness and buyer disclaim any express or implied warranty, including, without limitation, warranties or merchantability and/or fitness for a particular purpose with respect to the equipment. Buyer assumes all liability to use of equipment.

# TABLE OF CONTENTS

## RM-6 RACK

Included Tools.....	3
Included Parts.....	4
Assembly.....	14

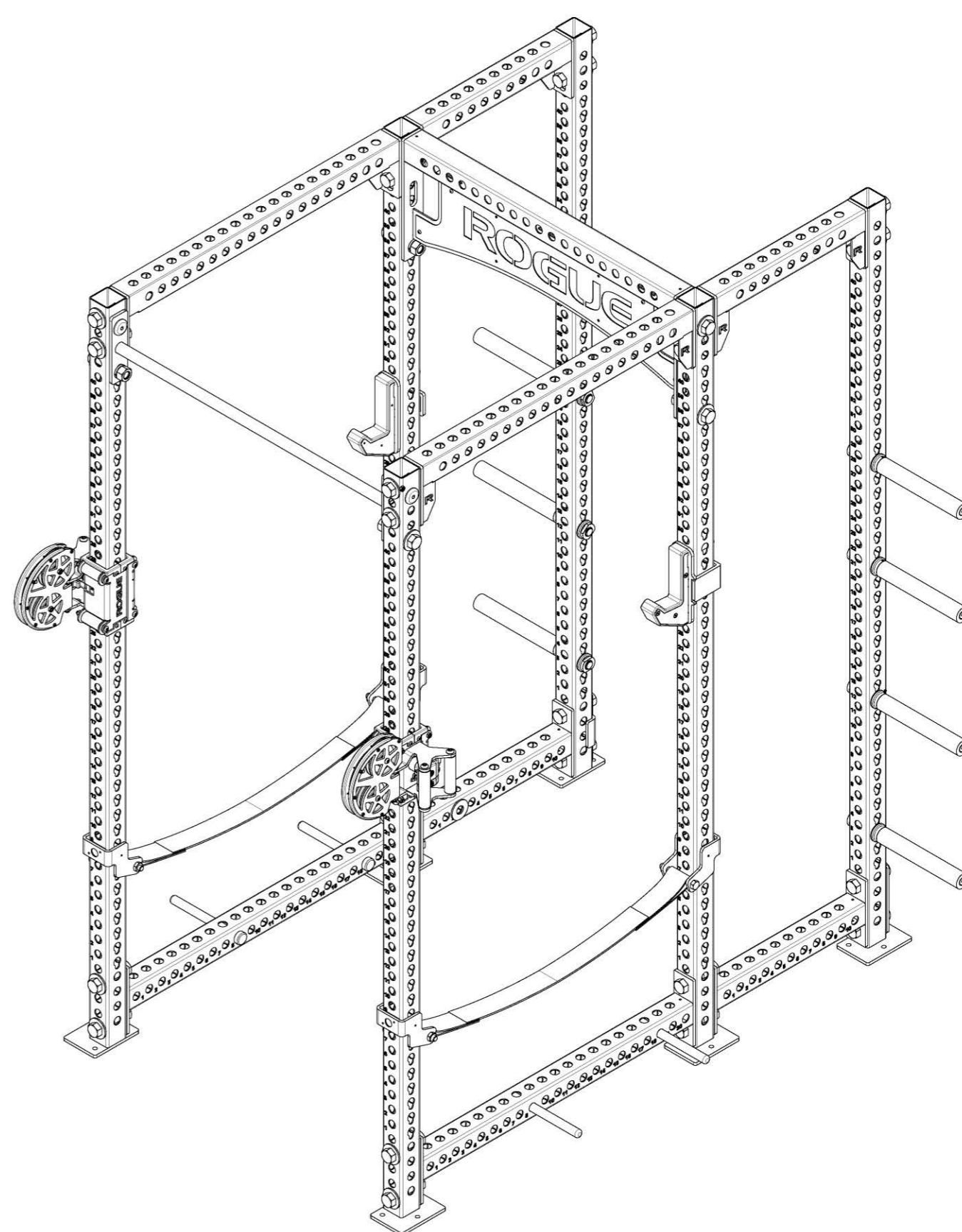

## FM-6 ADD-ON KIT

Included Tools.....	3
Included Parts.....	6
Assembly.....	18

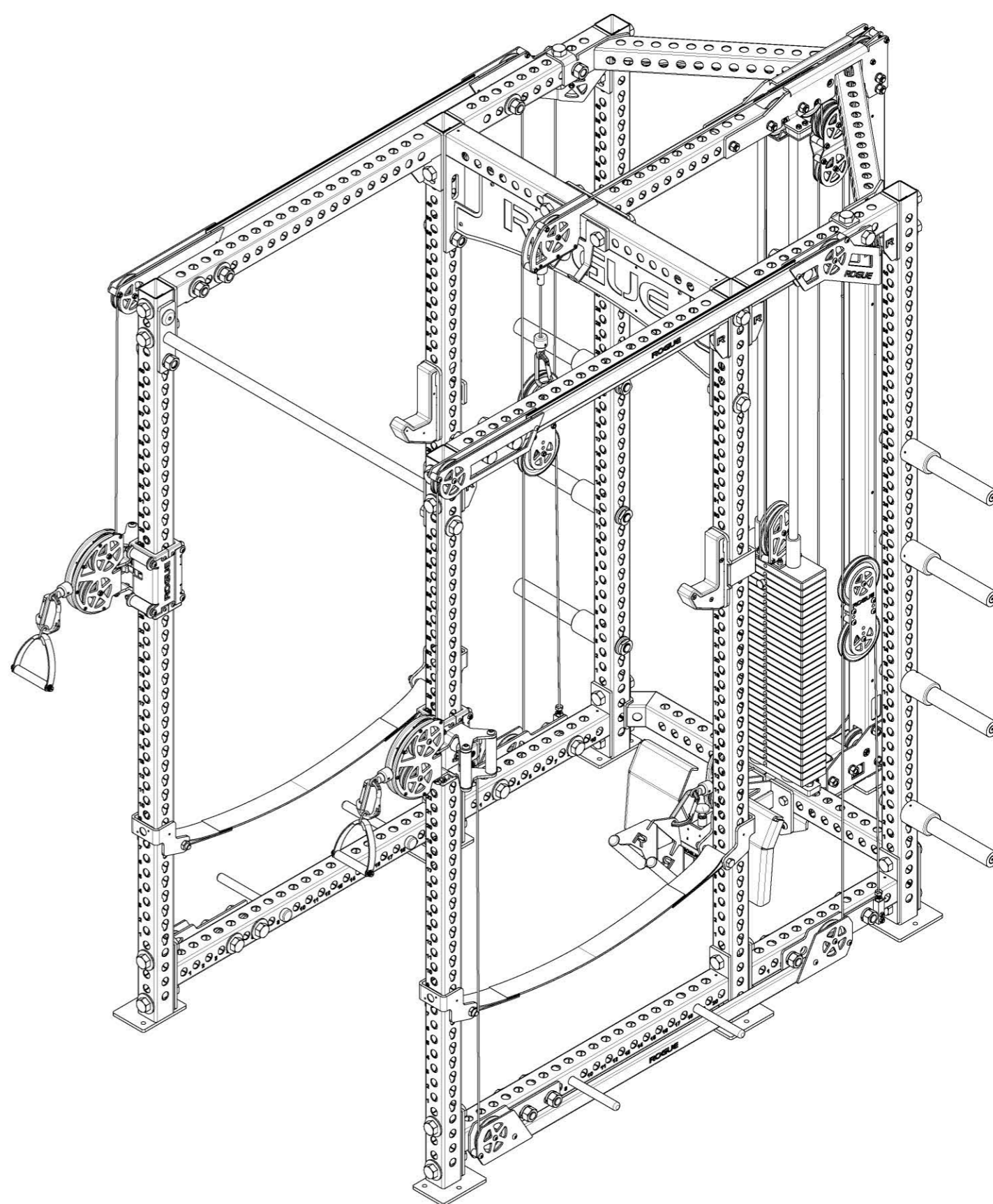

## FM-6 SHROUD KIT

Included Tools.....	3
Included Parts.....	12
Assembly.....	52

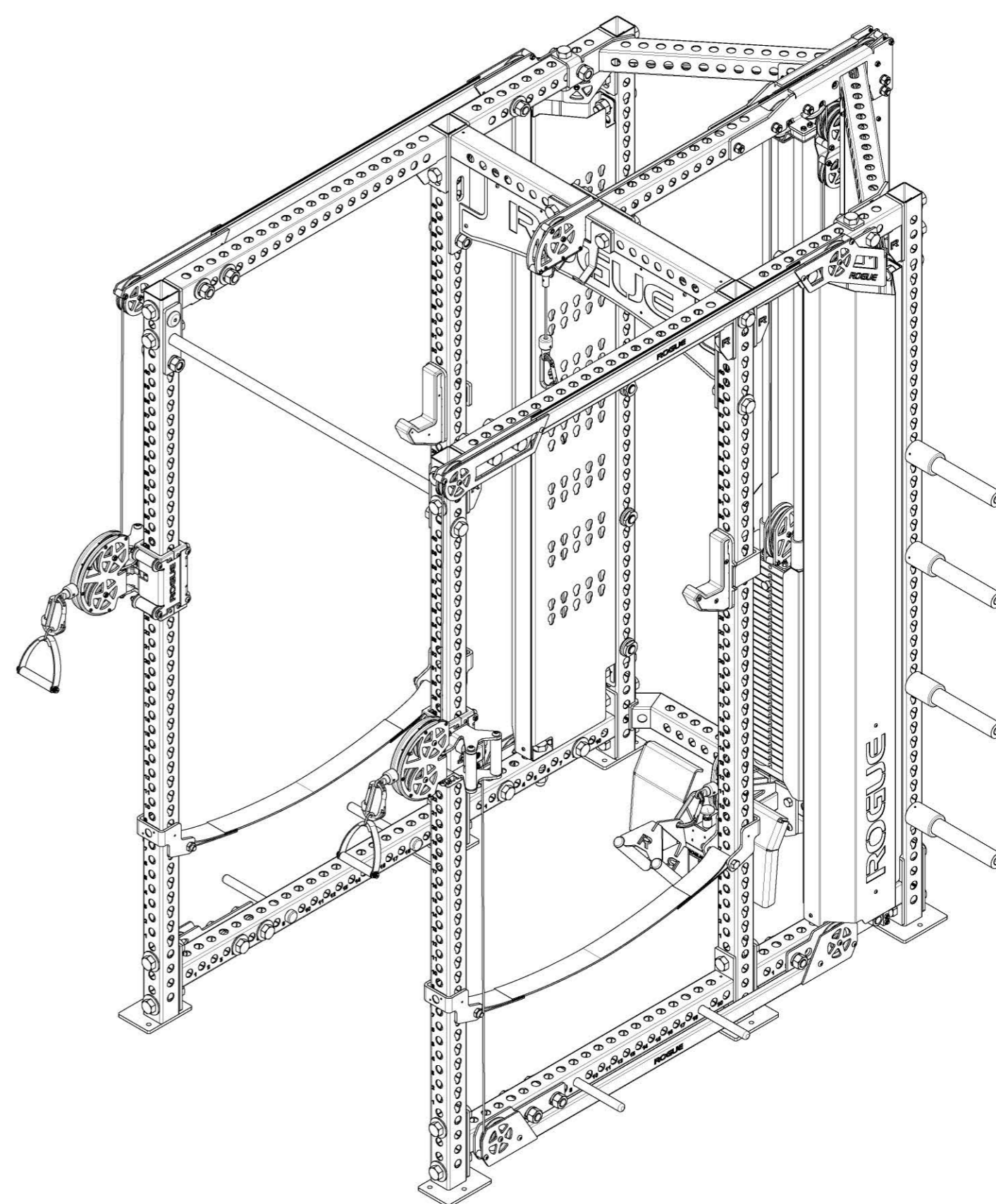

# INCLUDED TOOLS

Note: Images not shown at scale

**1** Qty: **2x**

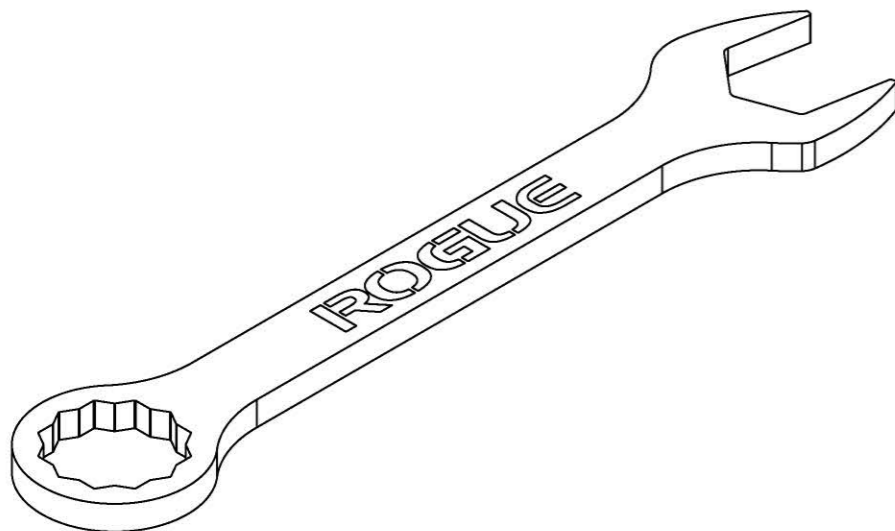

1-1/2" Wrench

**2** Qty: **2x**

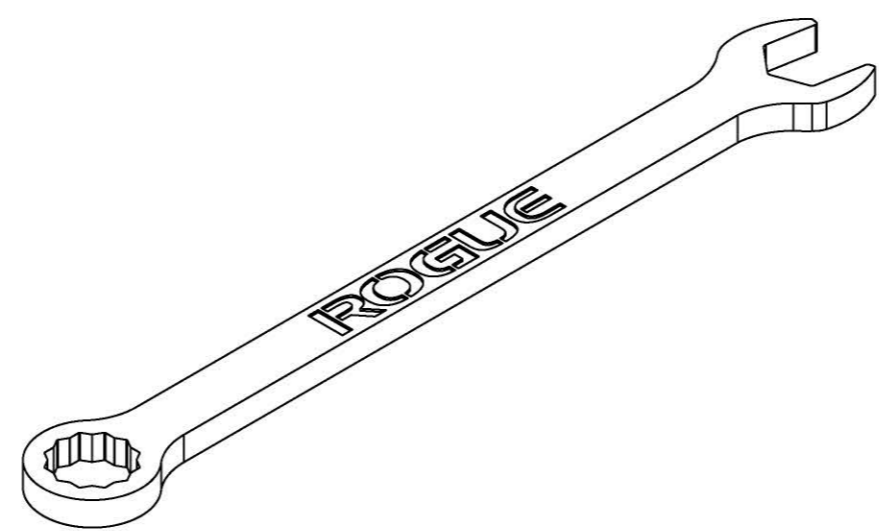

15/16" Wrench

**3** Qty: **1x**

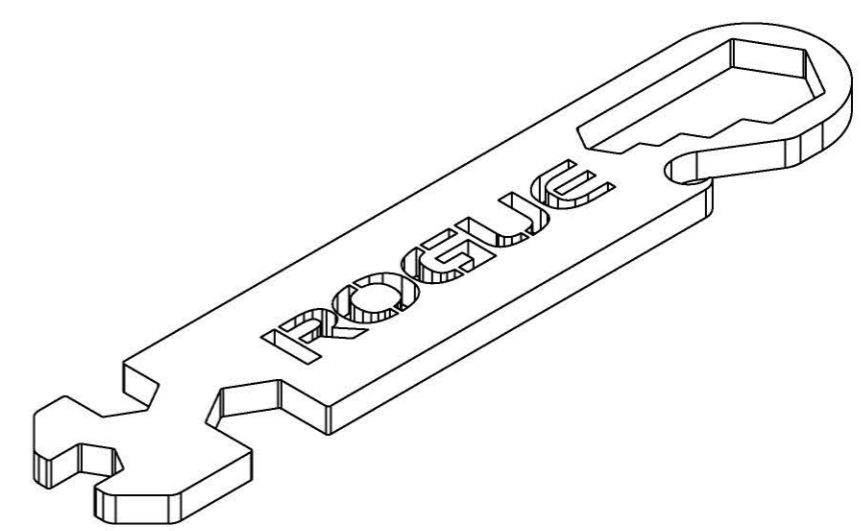

Multi Tool (3/4", 9/16", and 7/16" Wrench)

**4** Qty: **1x**

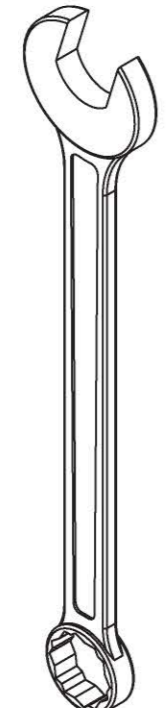

5/8" Wrench

**5** Qty: **1x**

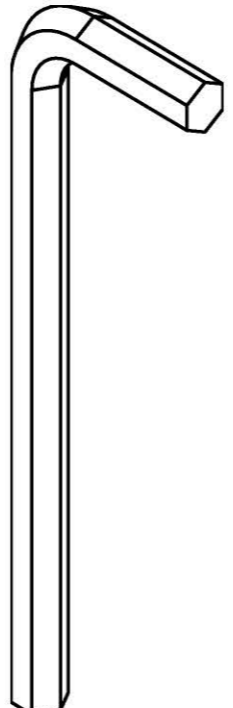

3/8" Allen Key

**6** Qty: **1x**

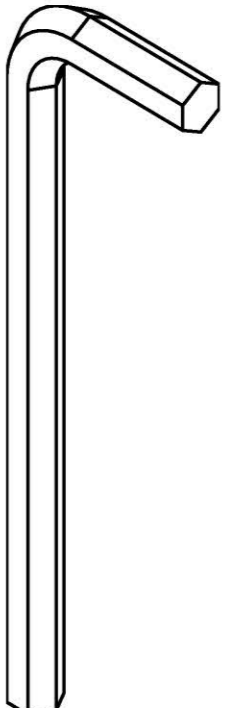

5/16" Allen Key

**7** Qty: **1x**



7/32" Allen Key

**8** Qty: **1x**



5/32" Allen Key

**9** Qty: **1x**

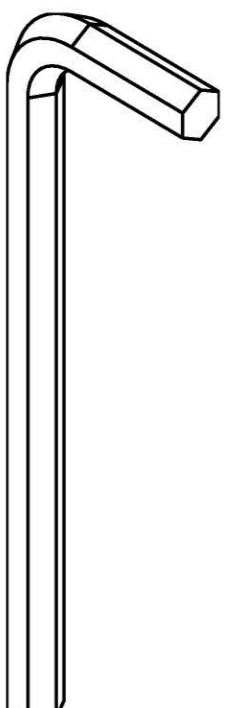

1/8" Allen Key

**10** Qty: **1x**



3/32" Allen Key

# INCLUDED PARTS: RM-6 FULL RACK

Note: Images not shown at scale.

**1** Qty: **6x**

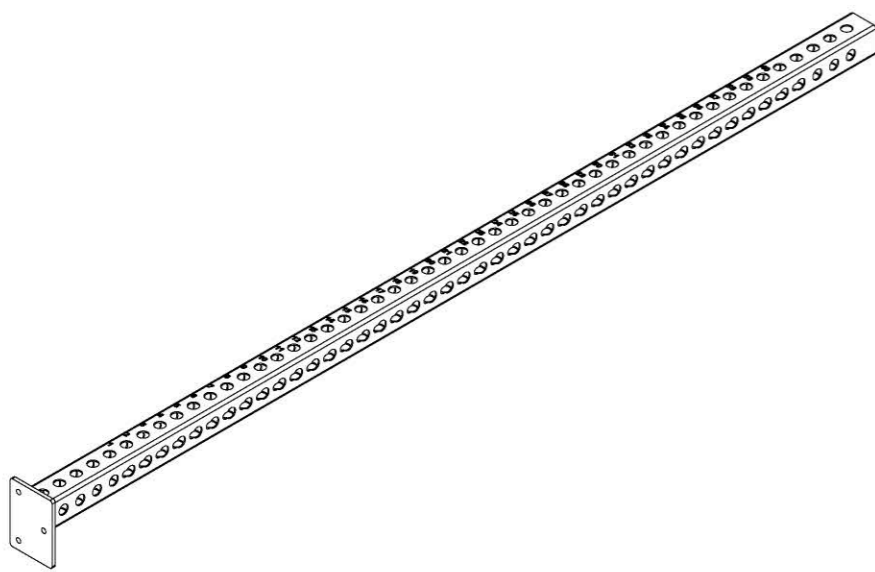

90" or 100" Monster Upright

**2** Qty: **2x**

\*

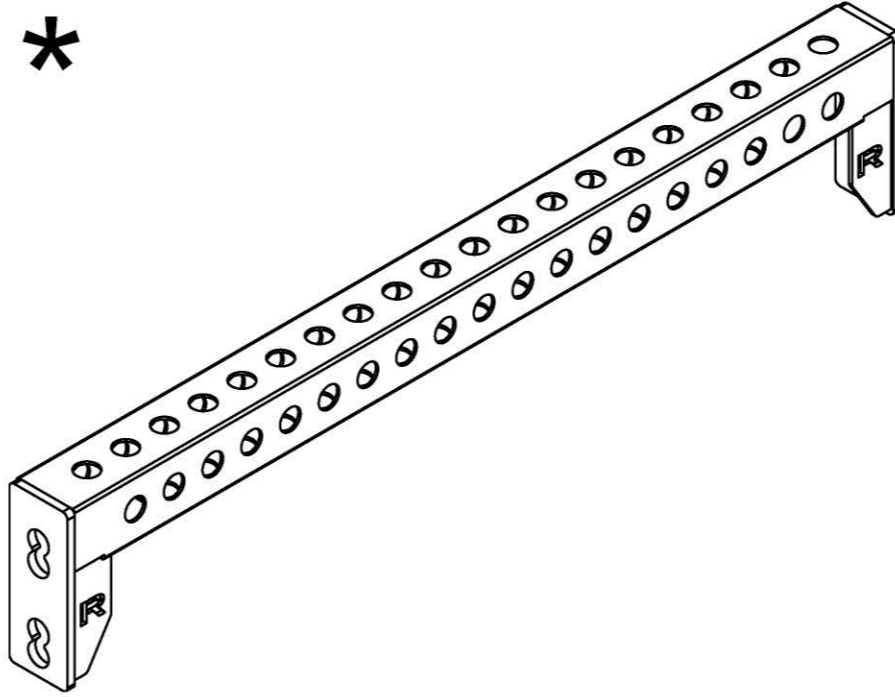

Front Top Crossmember

**3** Qty: **2x**

\*

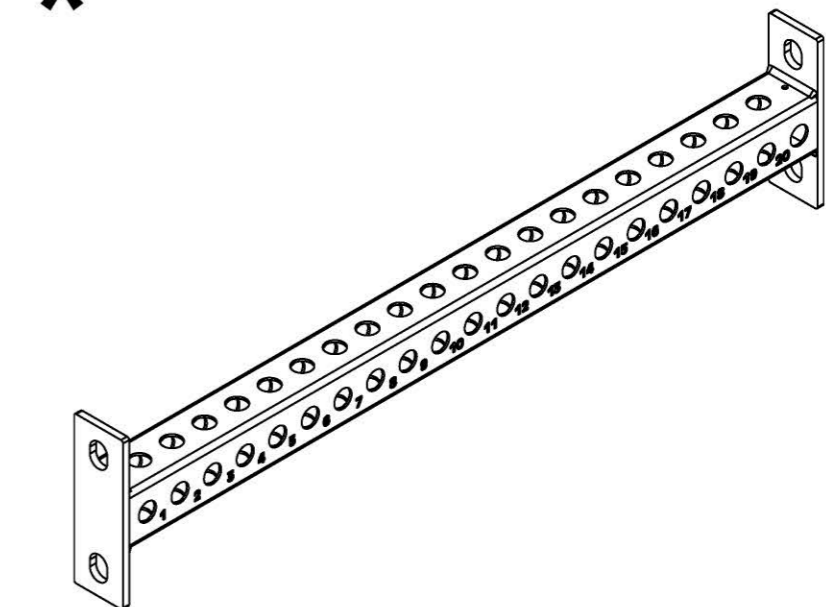

Front Low Crossmember

**4** Qty: **2x**

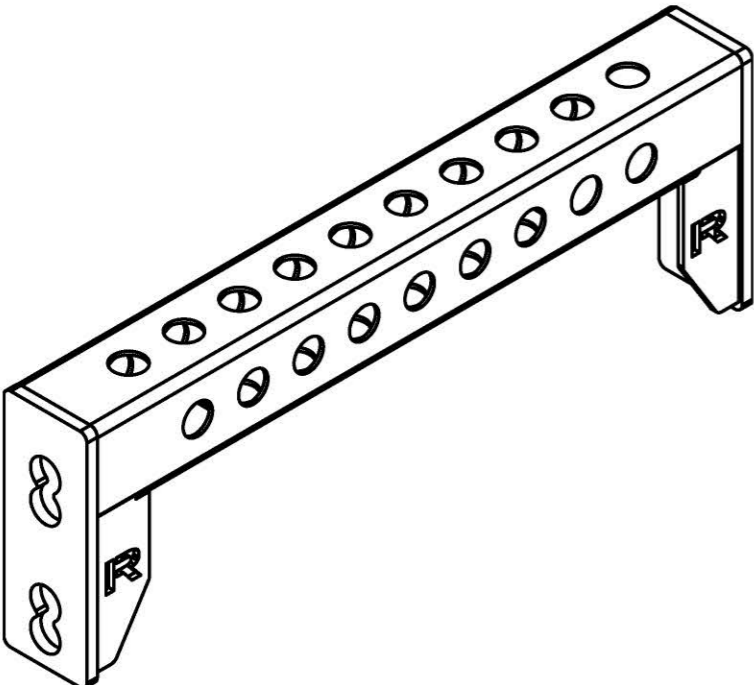

24" Rear Top Crossmember

**5** Qty: **2x**

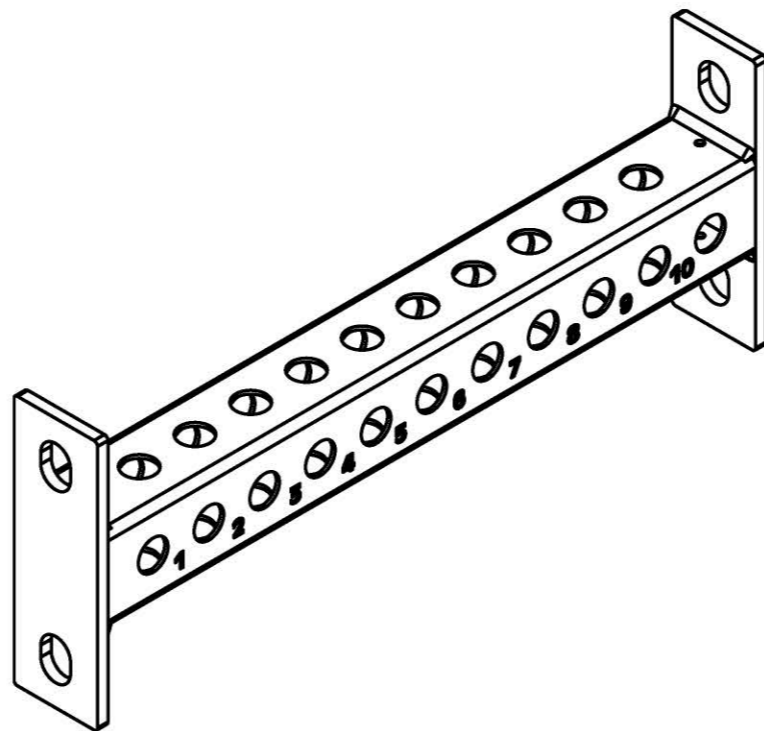

24" Rear Low Crossmember

**6** Qty: **1x**

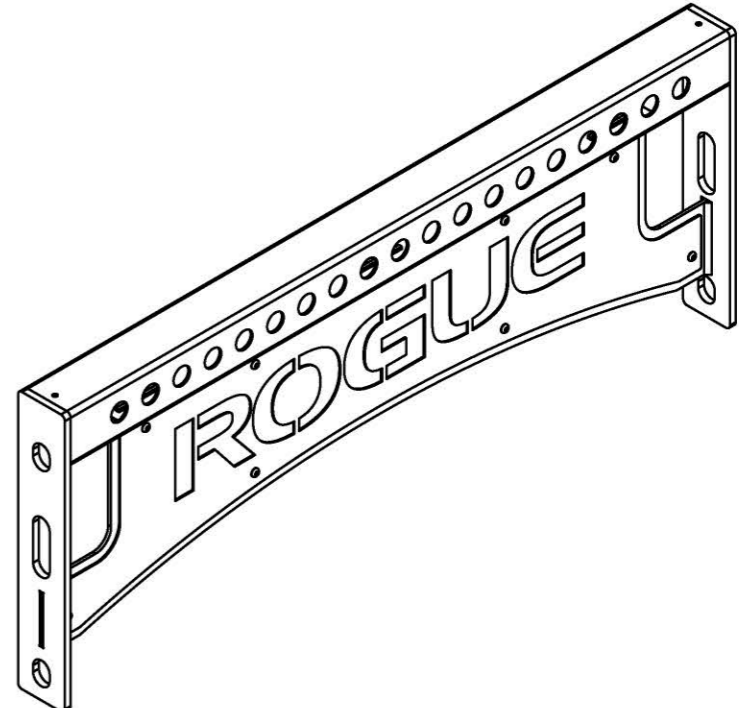

Nameplate Crossmember

**7** Qty: **1x**

\*\*

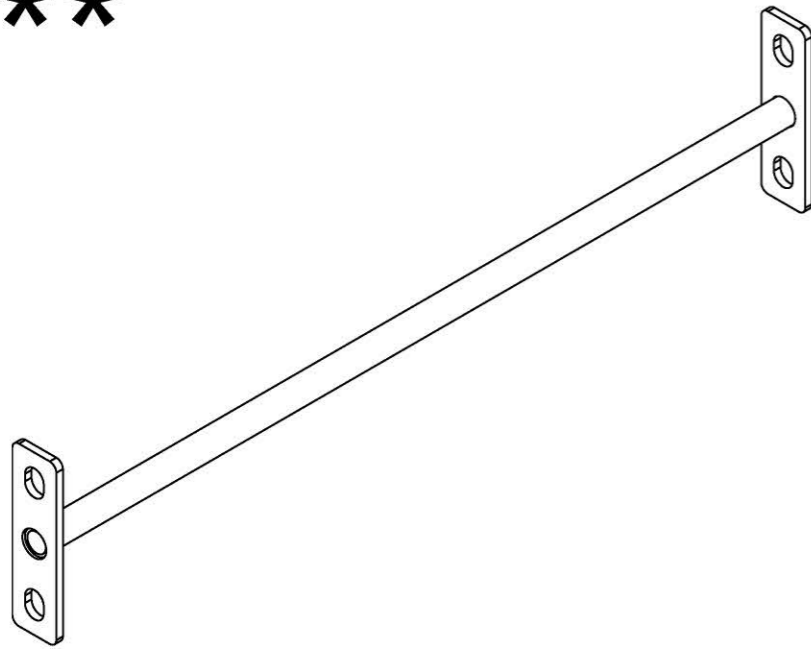

Pull-up Bar

**8** Qty: **8x**

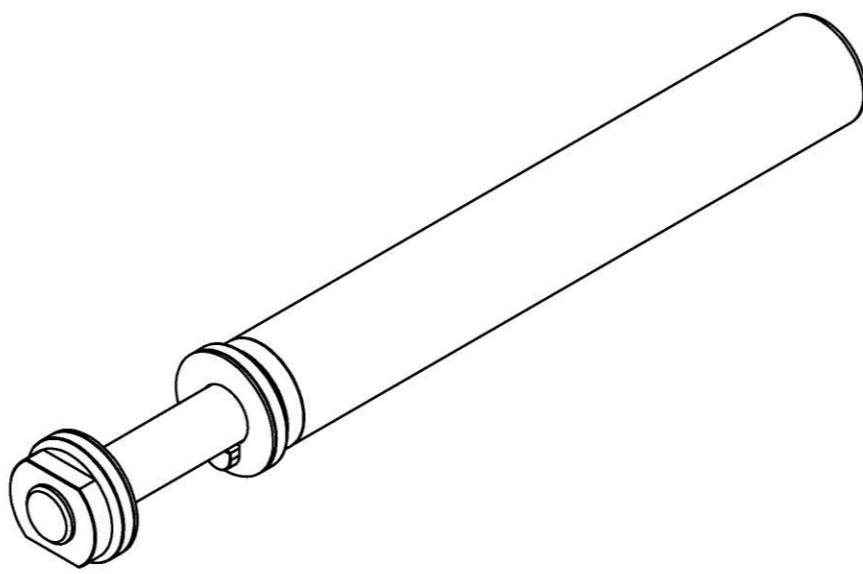

Monster Plate Storage Pin

**9** Qty: **1x**

\*\*

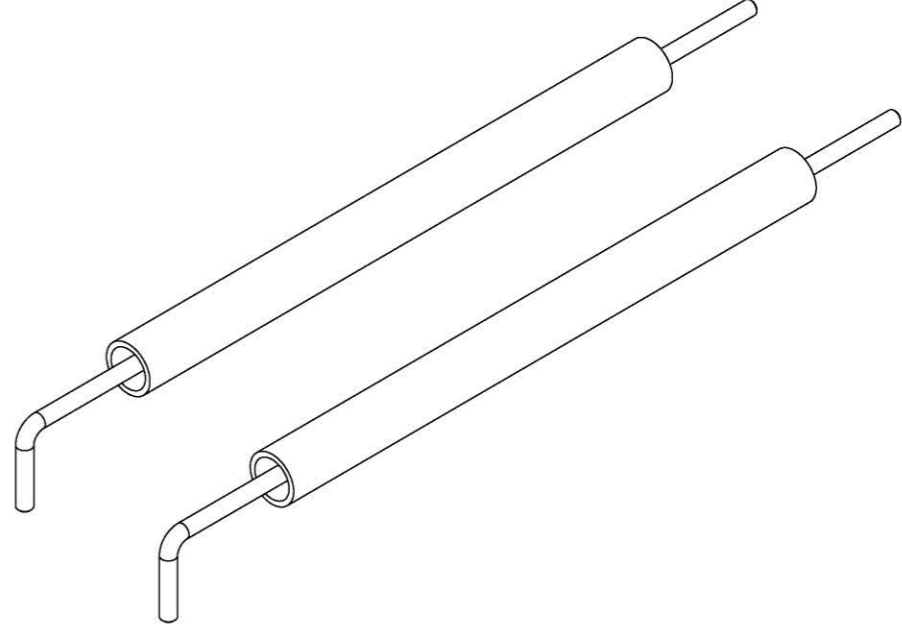

Pair of Safety Spotter Arms

**10** Qty: **4x**

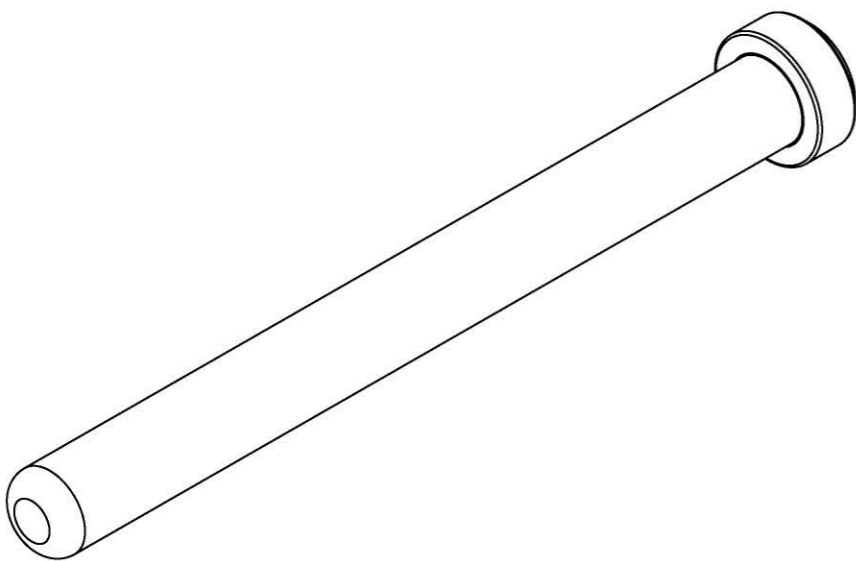

Band Peg

**11** Qty: **1x**

\*\*

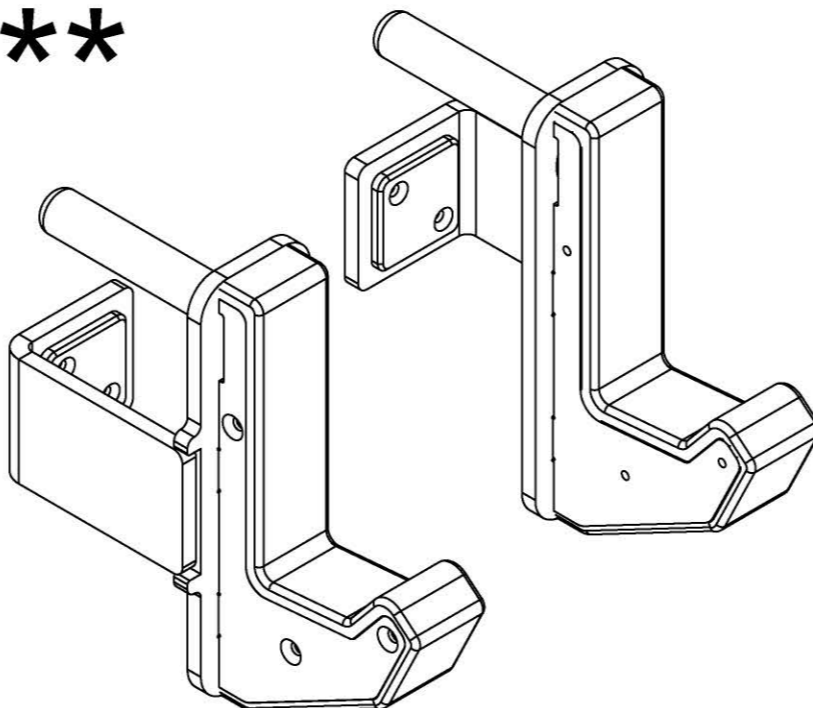

Pair of Monster J-cups

**12** Qty: **8x**

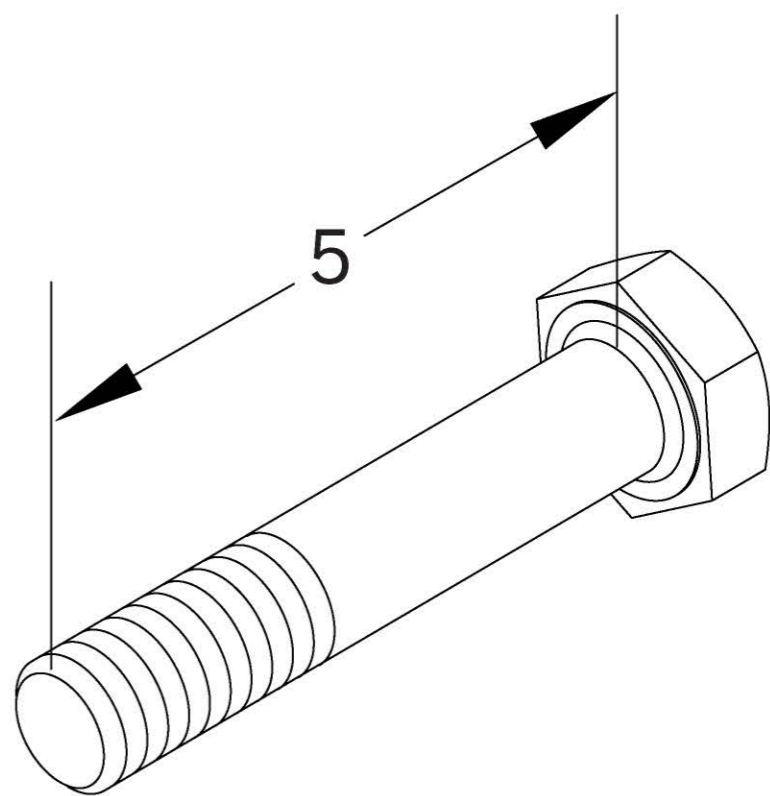

1" x 5" Hex Bolt

\* Front Crossmember length depends on Rack Depth selection made at checkout.

\*\* Items may look different than drawings shown. Style depends on selection made at checkout.

# INCLUDED PARTS: RM-6 FULL RACK

Note: Images not shown at scale.

**13** Qty: **24x**

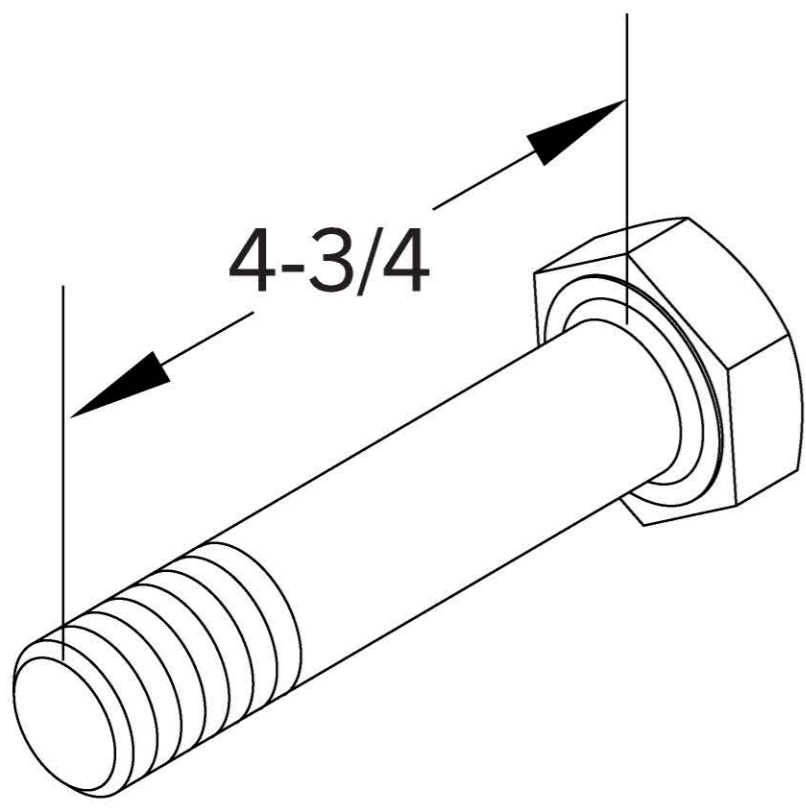

1" x 4-3/4" Hex Bolt

**14** Qty: **24x**

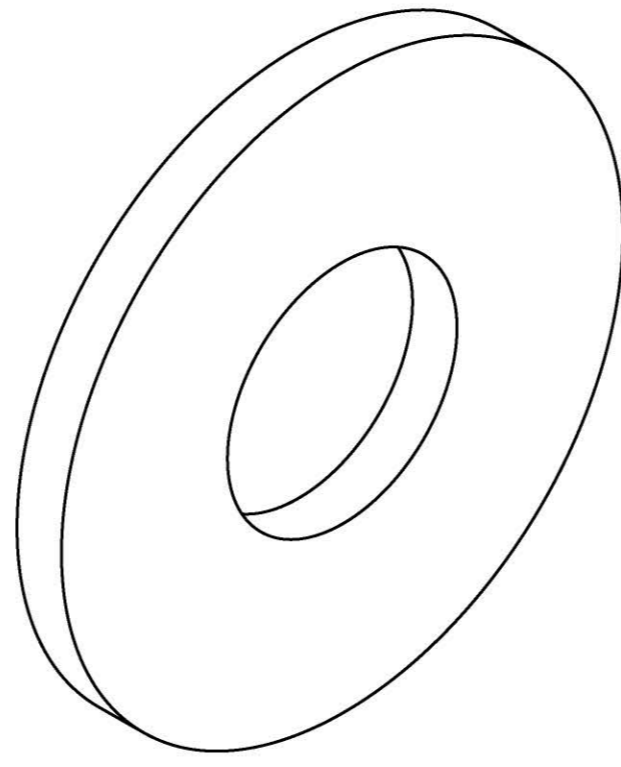

1" Flat Washer

**15** Qty: **32x**

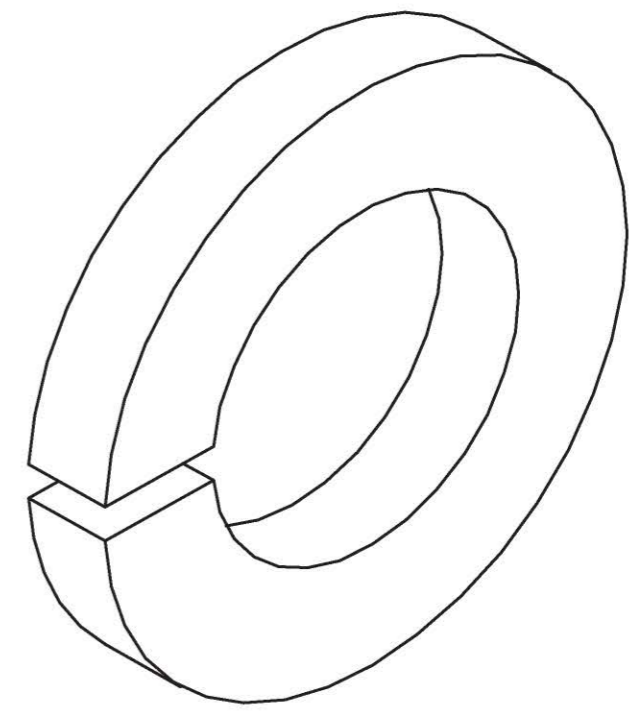

1" Lock Washer

**16** Qty: **32x**

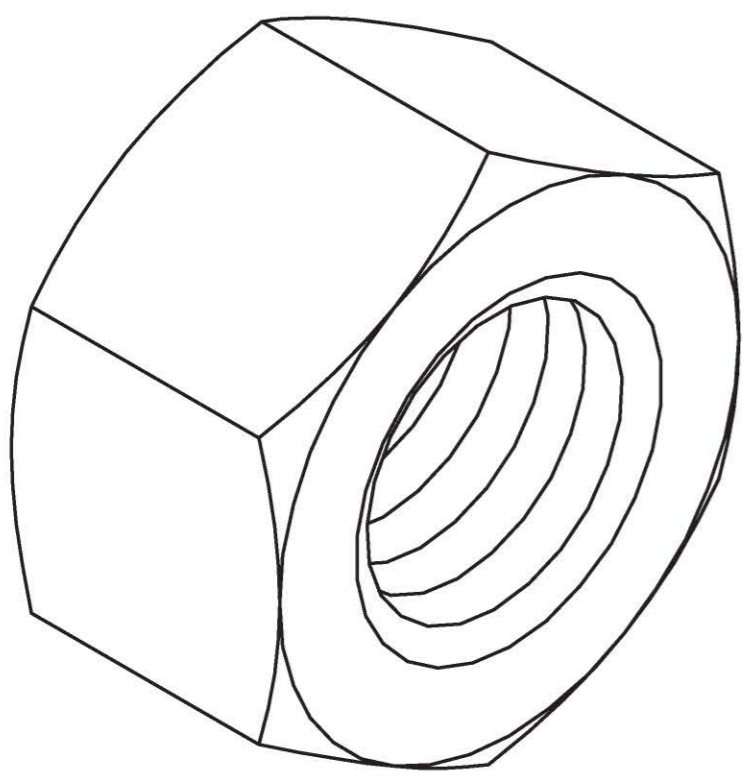

1" Hex Nut

# INCLUDED PARTS: FM-6 ADD-ON KIT

Note: Images not shown at scale.

**17** Qty: **1x**

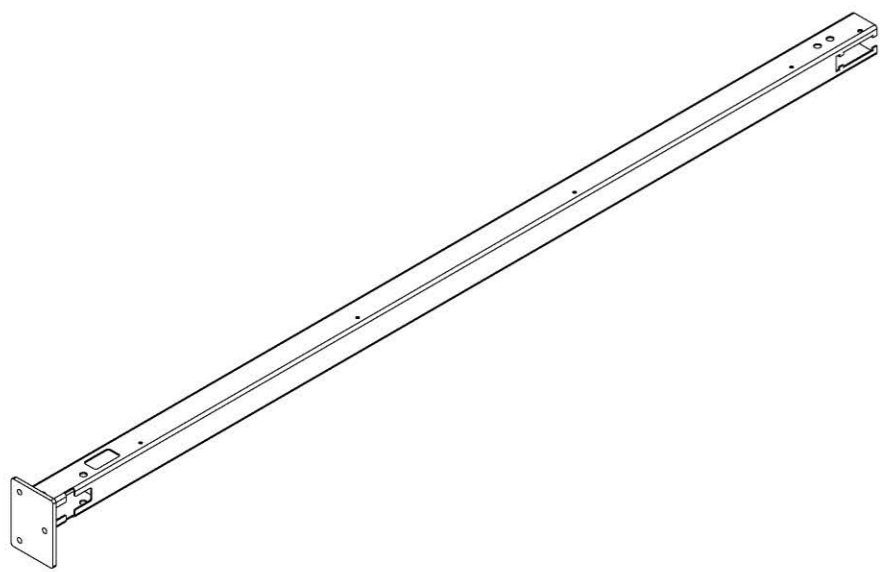

90" or 100" Rear 3X3 Upright

**18** Qty: **1x**

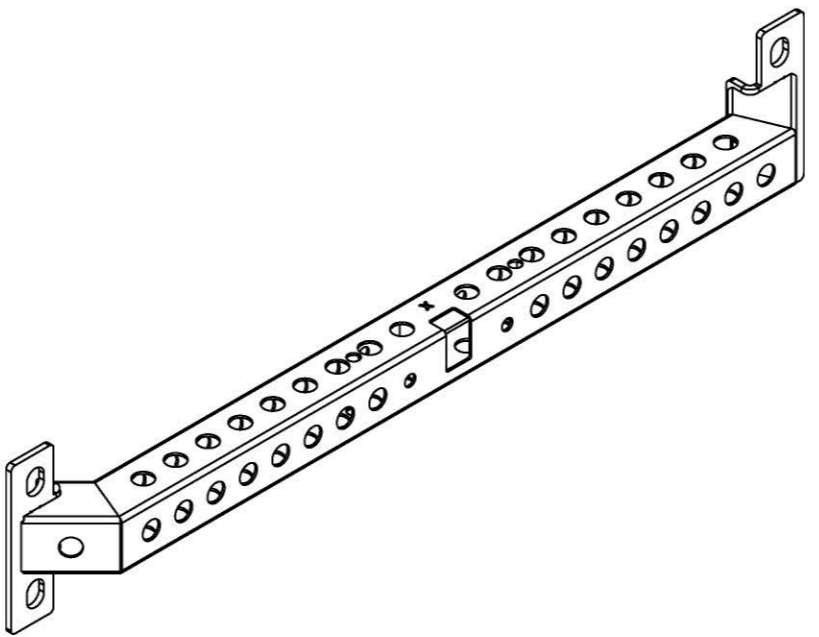

Low Row Crossmember

**19** Qty: **1x**

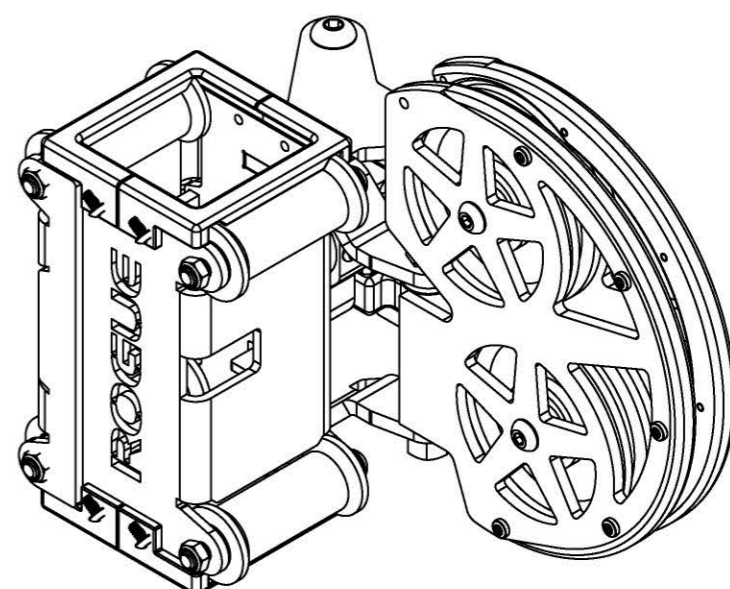

Swivel Trolley RH

**20** Qty: **1x**

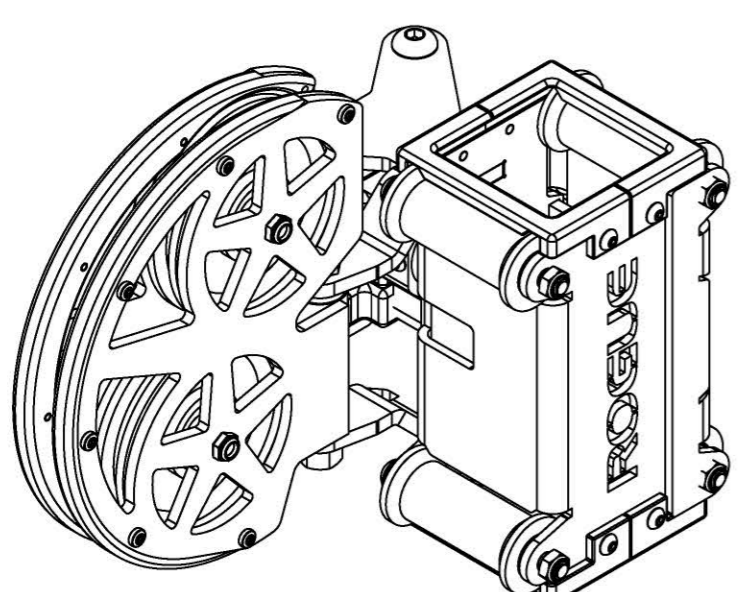

Swivel Trolley LH

**21** Qty: **1x**



Top Center Crossmember

**22** Qty: **1x**

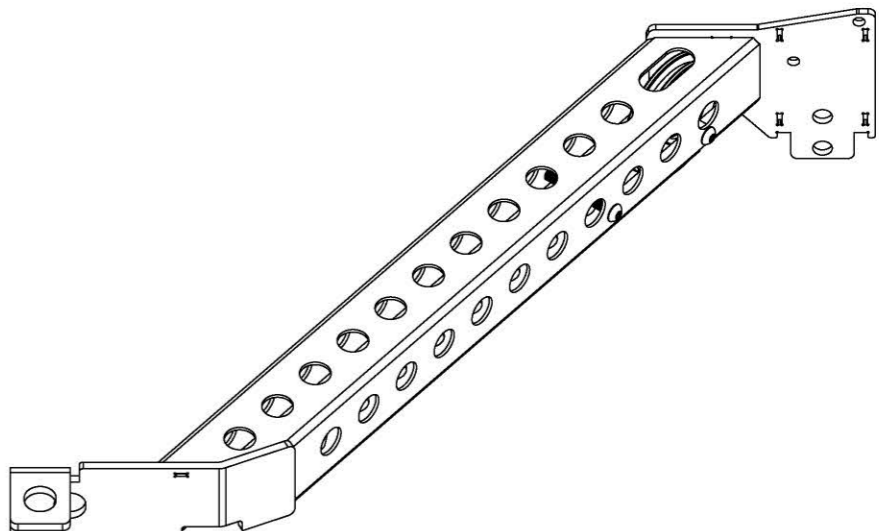

Top Rear Angle Crossmember - RH

**23** Qty: **1x**

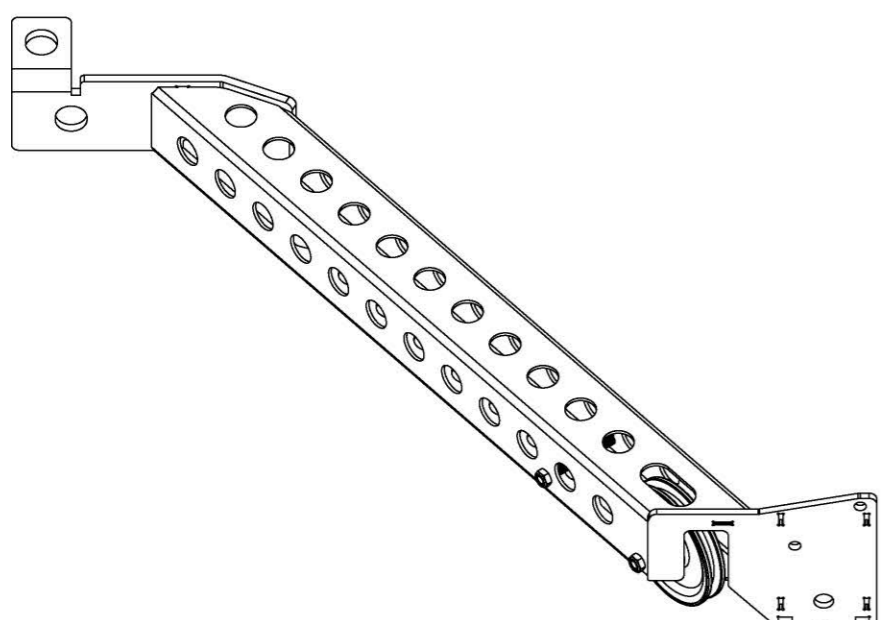

Top Rear Angle Crossmember - LH

**24** Qty: **1x**

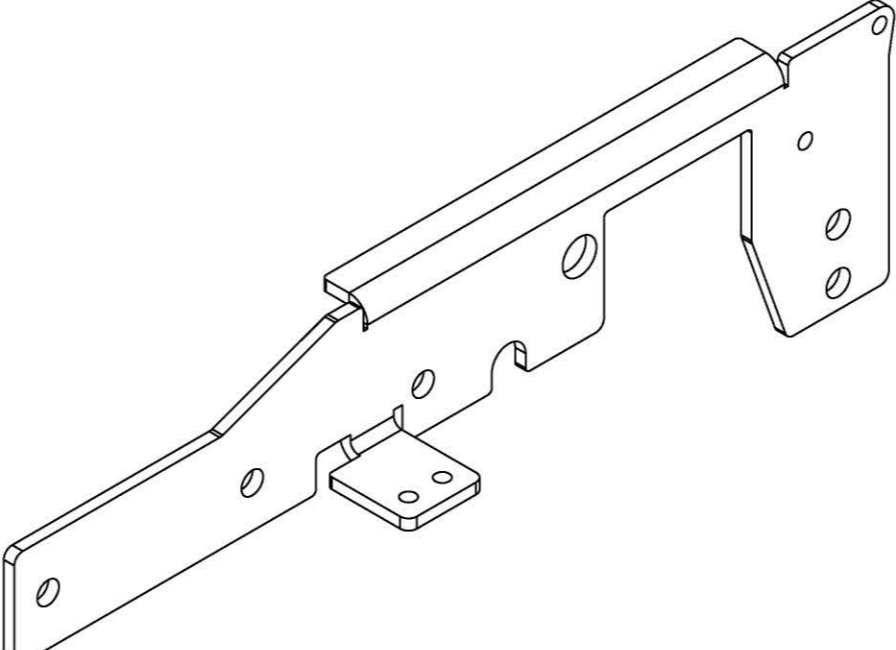

Top Rear Connector Plate - RH

**25** Qty: **1x**

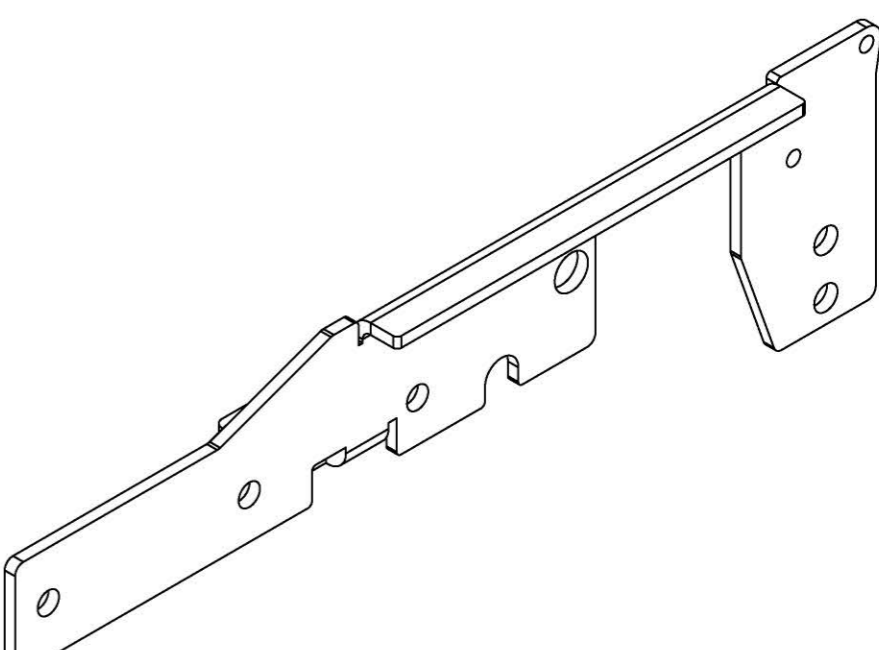

Top Rear Connector Plate - LH

**26** Qty: **1x**

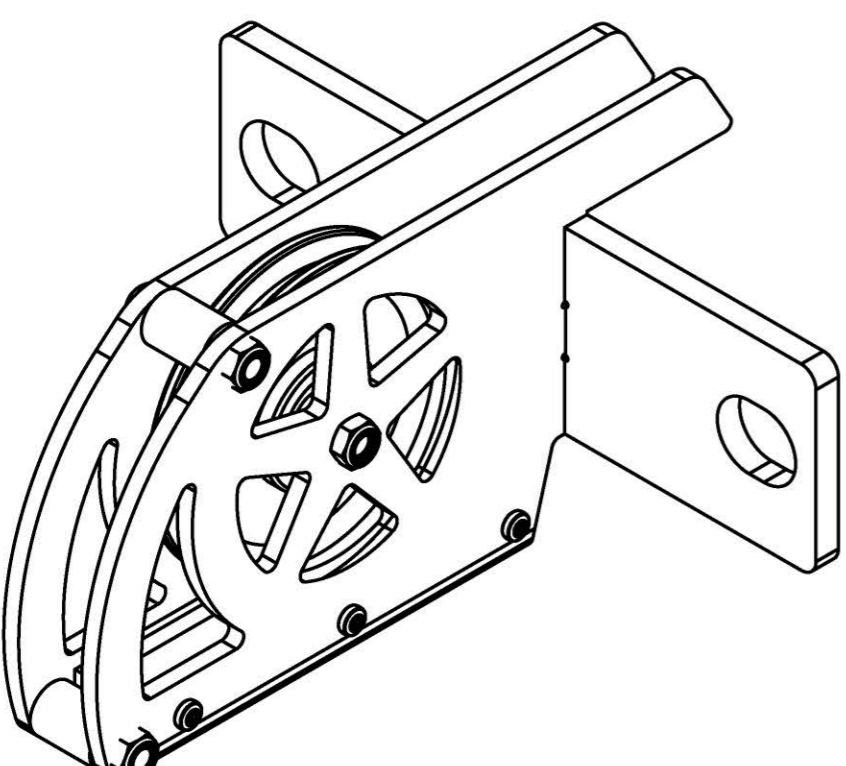

Lat Pulldown Pulley Bracket

**27** Qty: **1x**

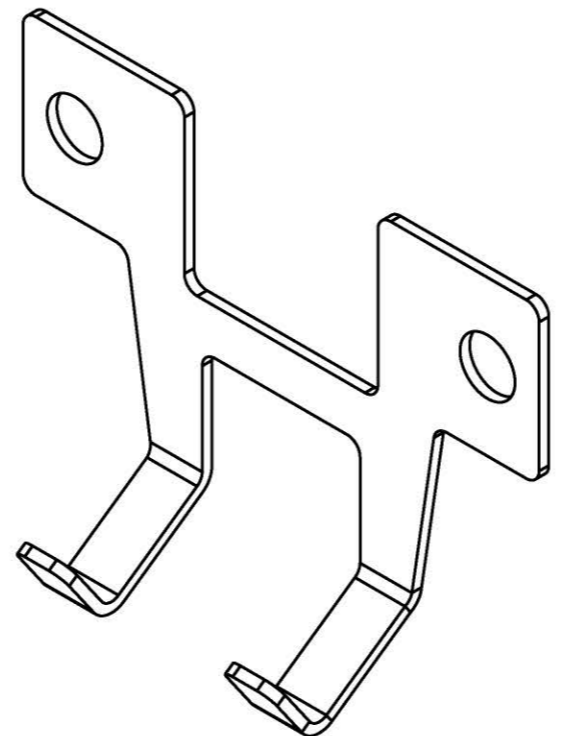

Lat Bar Hanger

**28** Qty: **1x**



Low Row Footplate Assembly

# INCLUDED PARTS: FM-6 ADD-ON KIT

Note: Images not shown at scale.

**29** Qty: **1x**

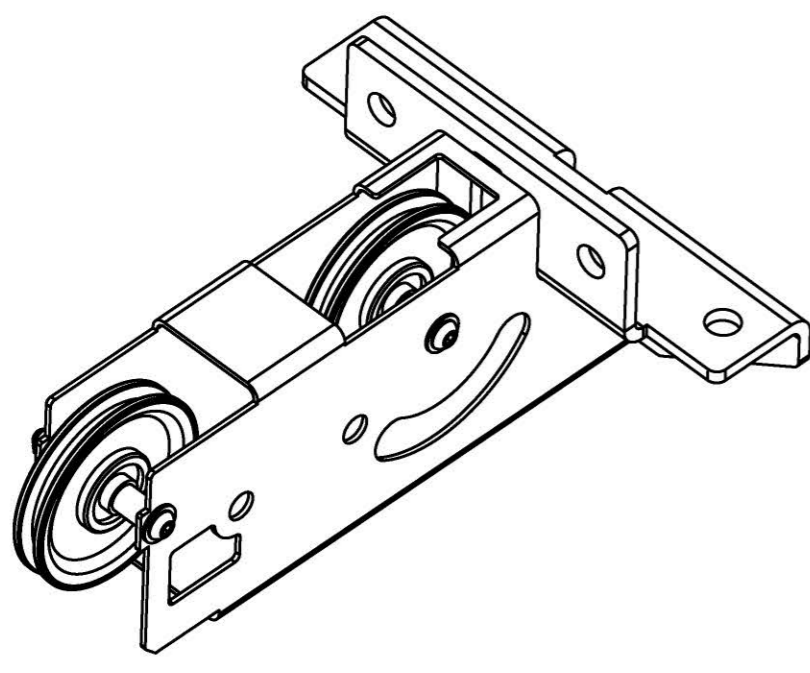

Low Rear Pulley Assembly

**30** Qty: **2x**

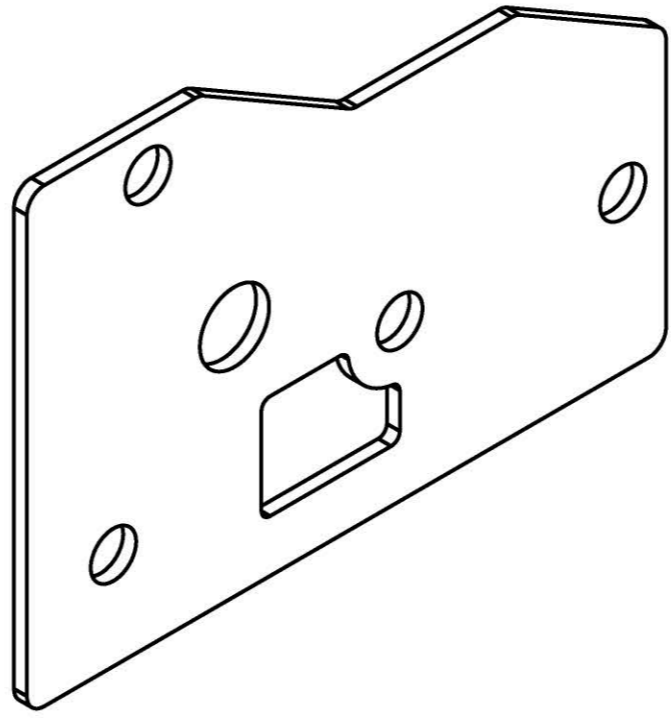

Rear Connector Plate

**31** Qty: **2x**

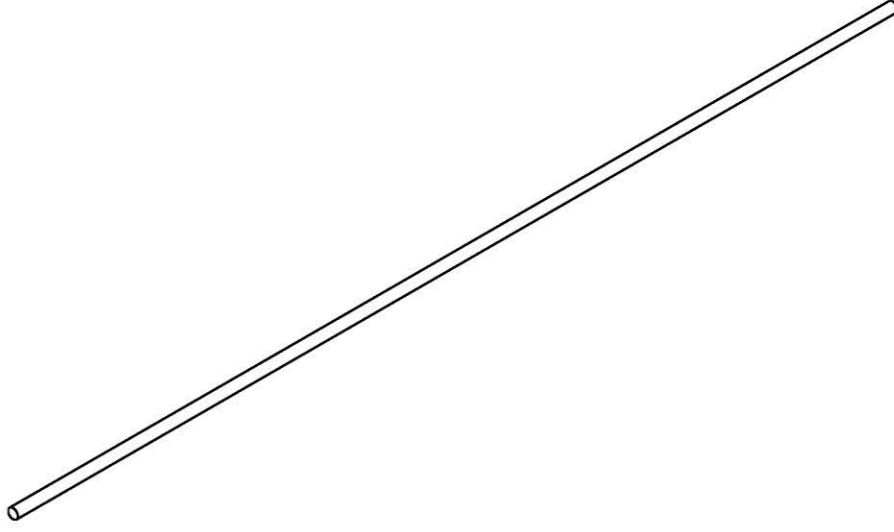

Guide Rod

**32** Qty: **1x**

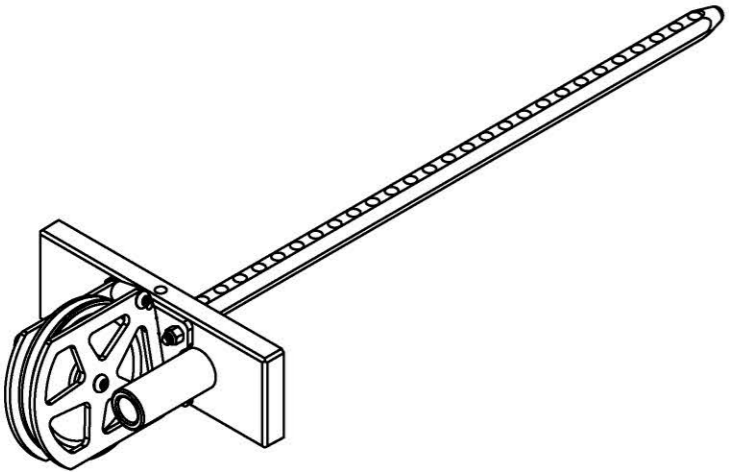

Weight Stack Stem

**33** \*Qty: **23x or 28x**

\*

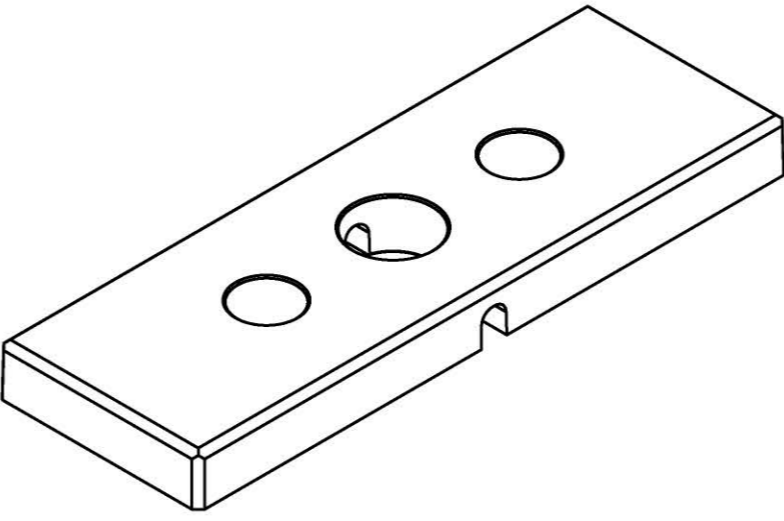

10LB Weight Stack Plate

**34** Qty: **1x**



Weight Stack Selector Pin w/ Lanyard

**35** Qty: **1x**

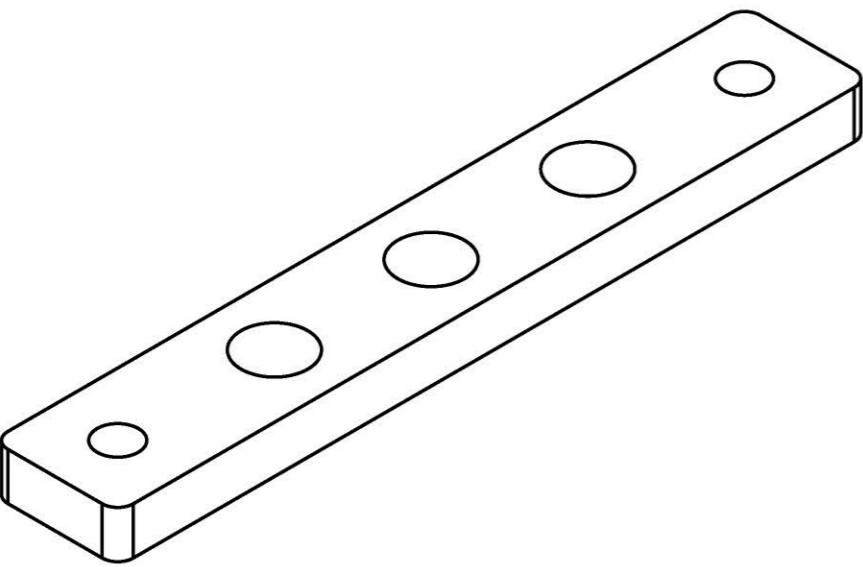

Weight Stack Spacer

**36** Qty: **1x**

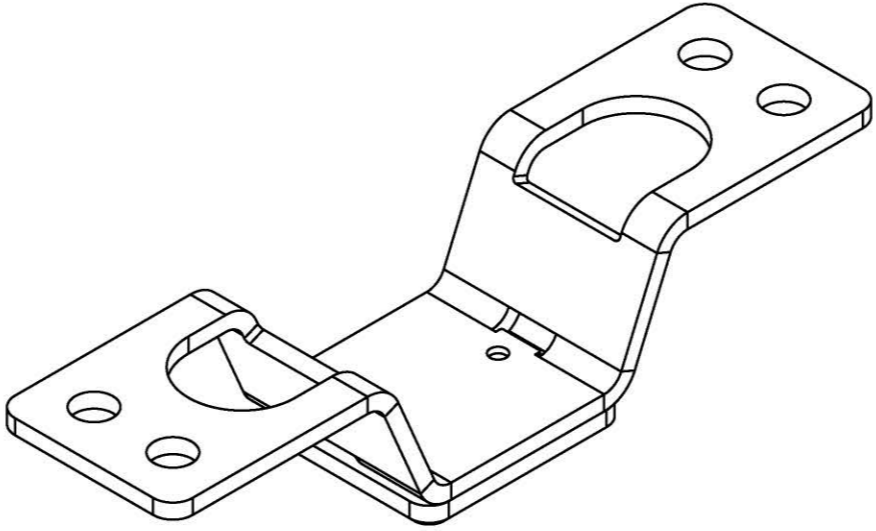

Top Weight Stack Stop Block

**37** Qty: **2x**

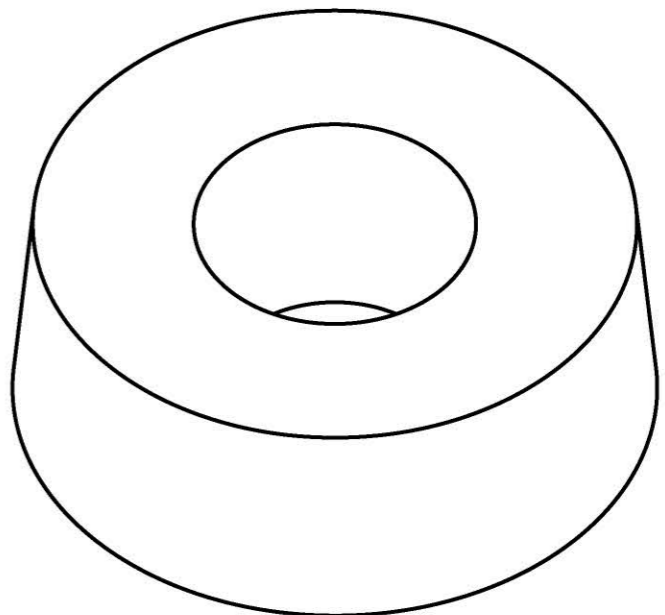

Weight Stack Bumper

**38** Qty: **2x**

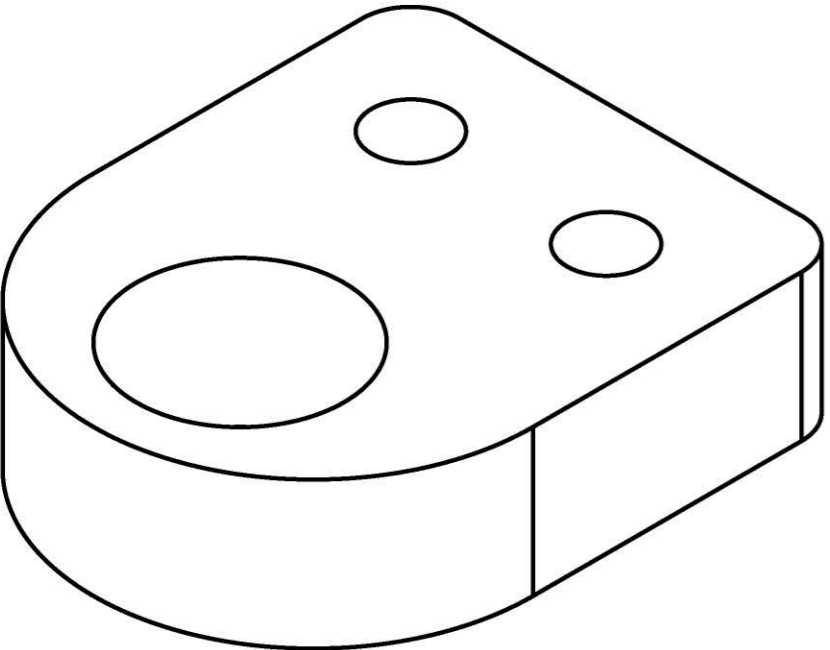

Guide Rod Spacer

**39** Qty: **2x**

\*\*

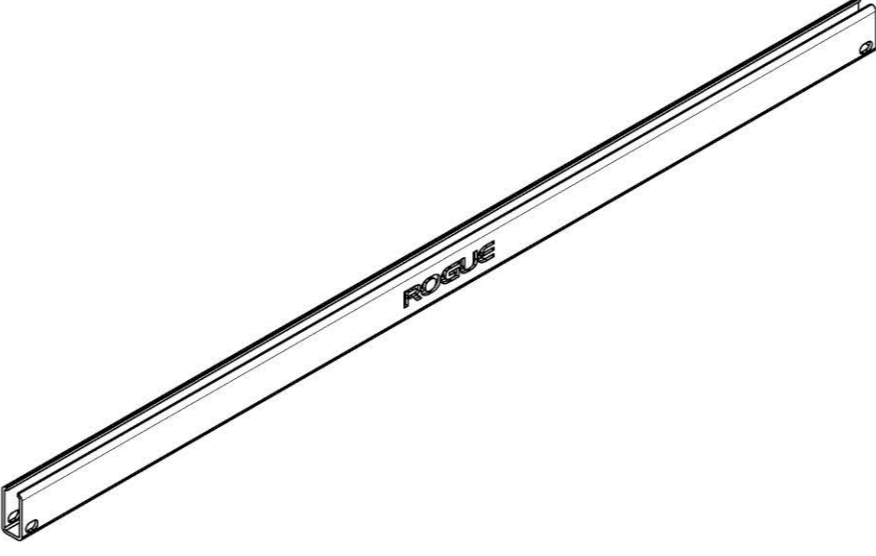

Top Cable Cover Rail (24", 30", or 43")

**40** Qty: **2x**

\*\*

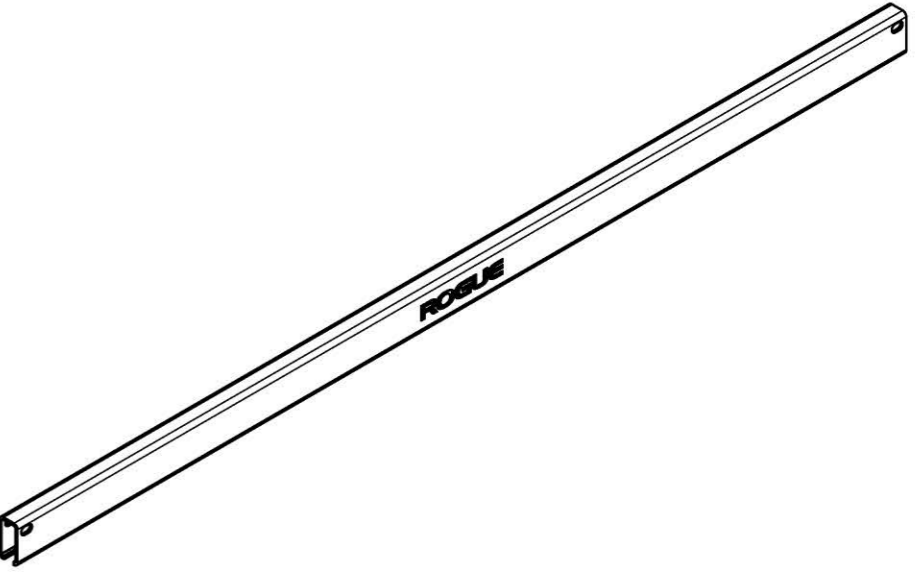

Low Cable Cover Rail (24", 30", or 43")

\* Quantity depends on 250 lb or 300 lb weight stack selected at checkout.

\*\* 24", 30", or 43" length depends on rack depth selection made at checkout.

# INCLUDED PARTS: FM-6 ADD-ON KIT

Note: Images not shown at scale.

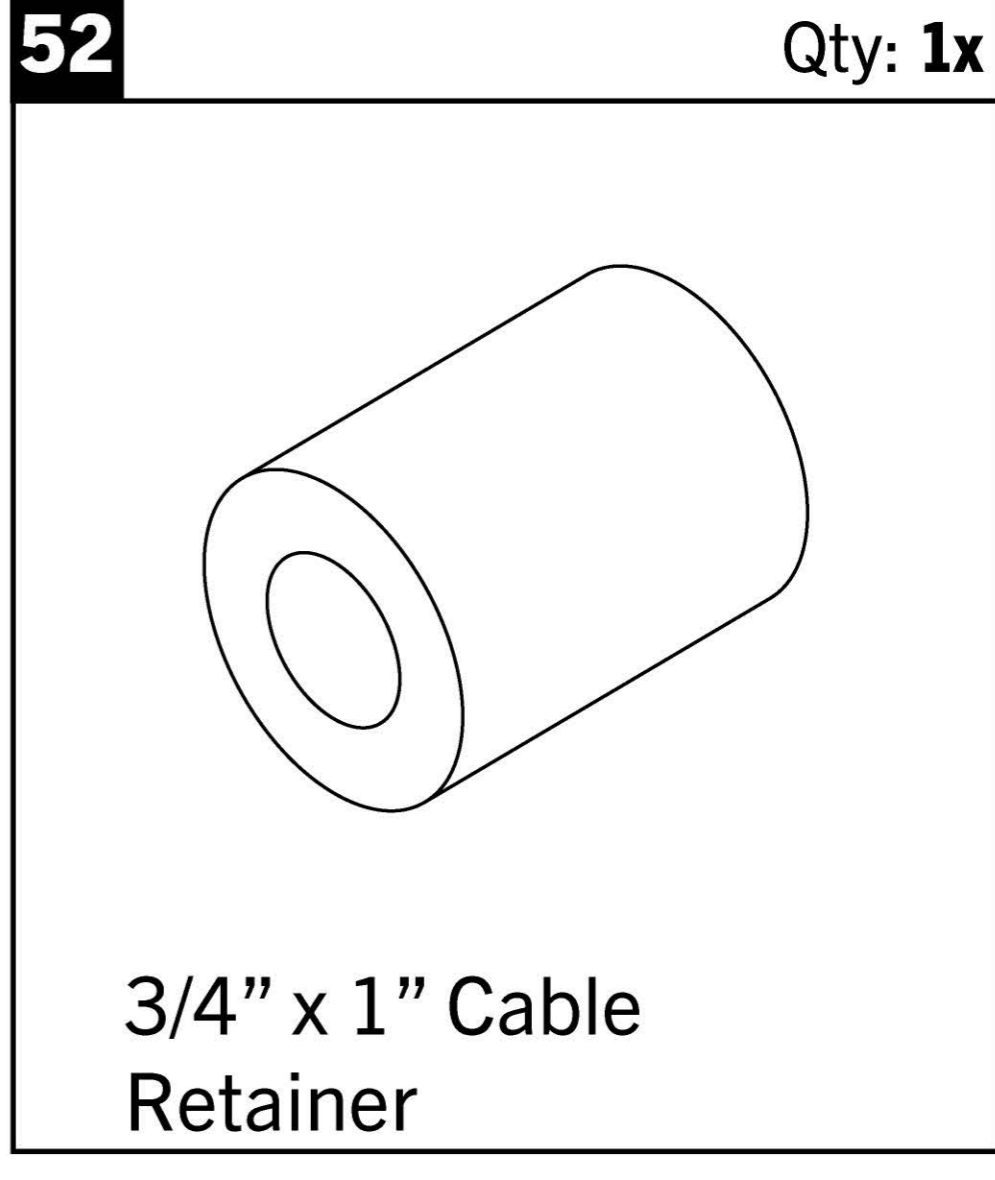
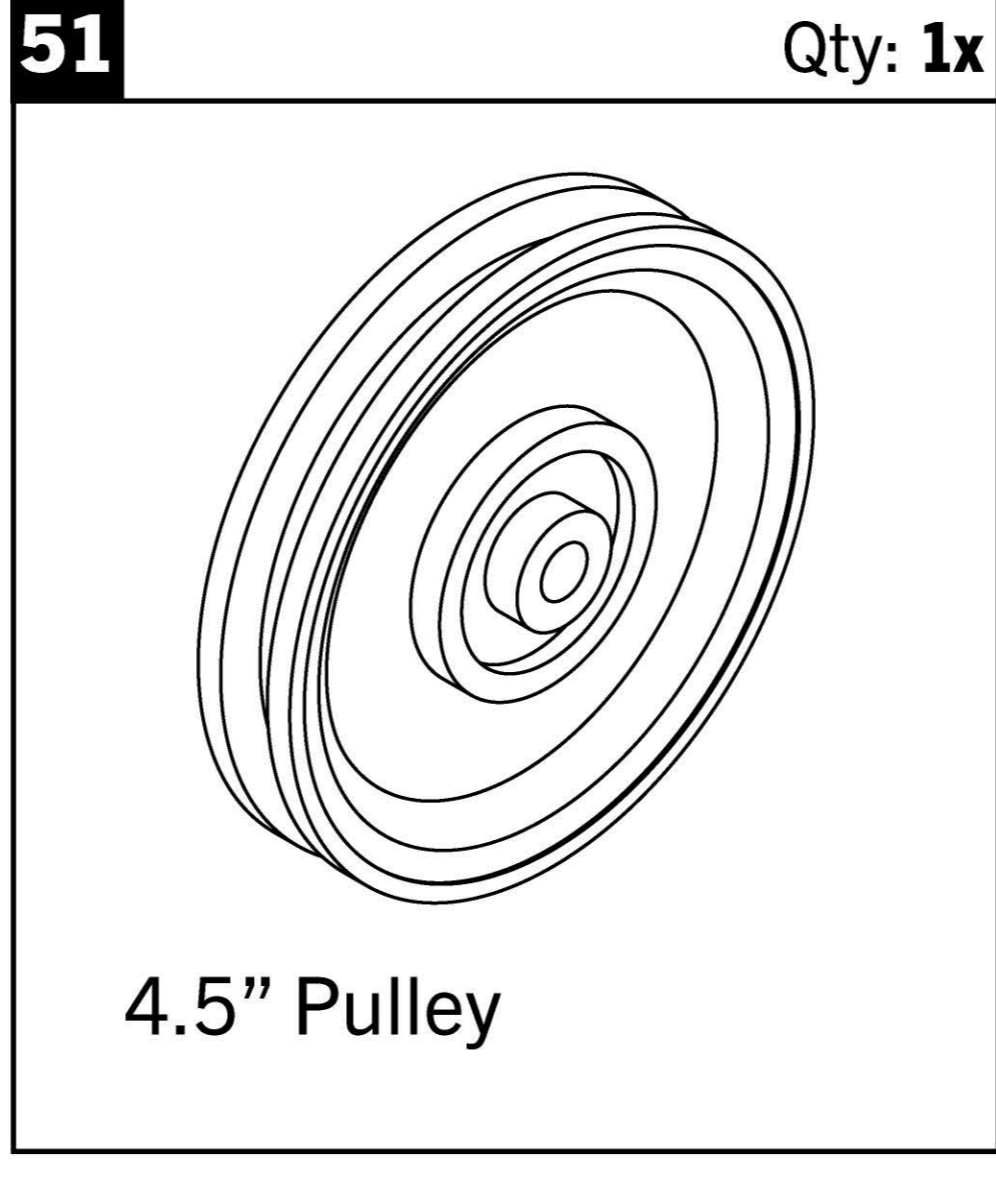
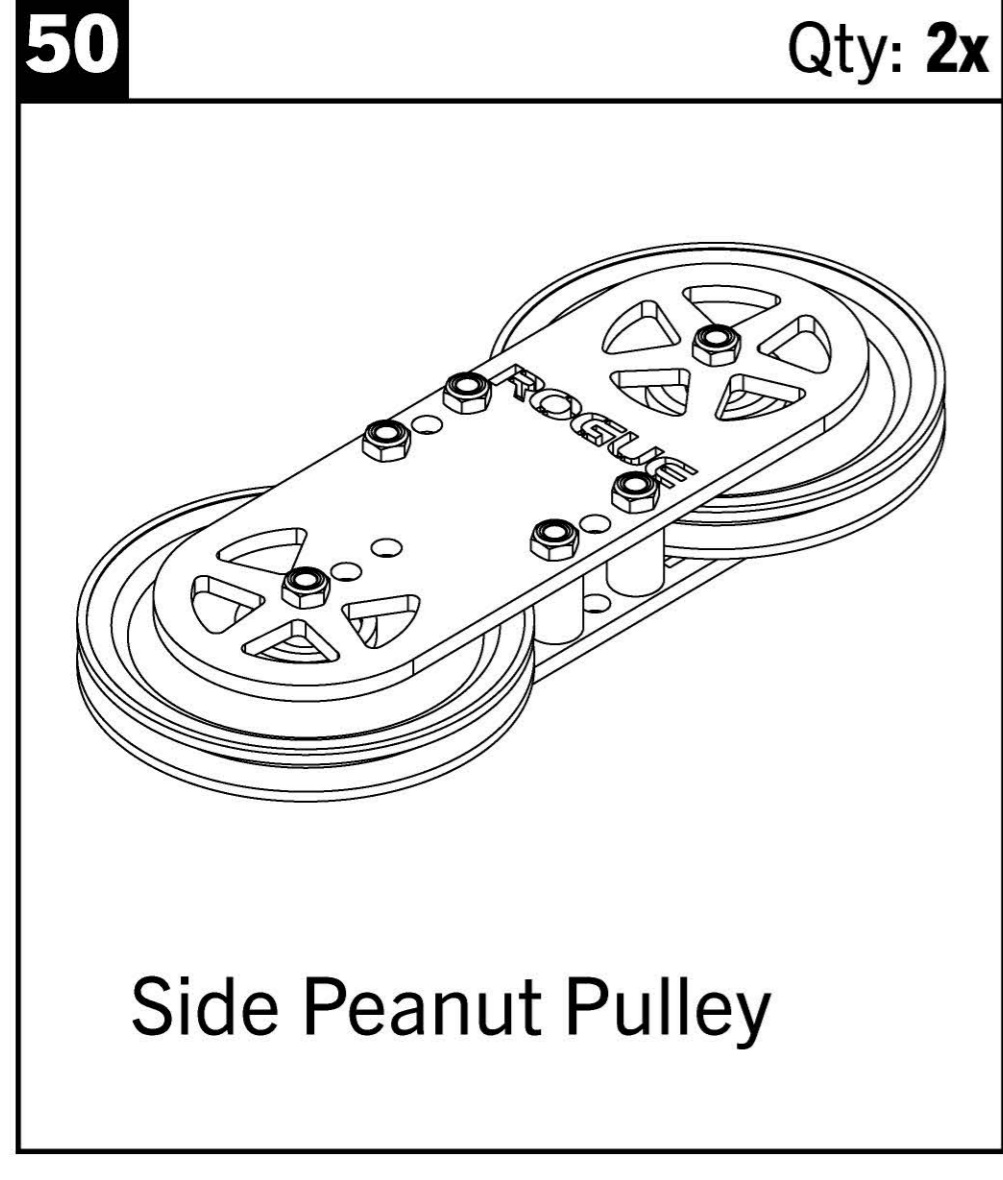
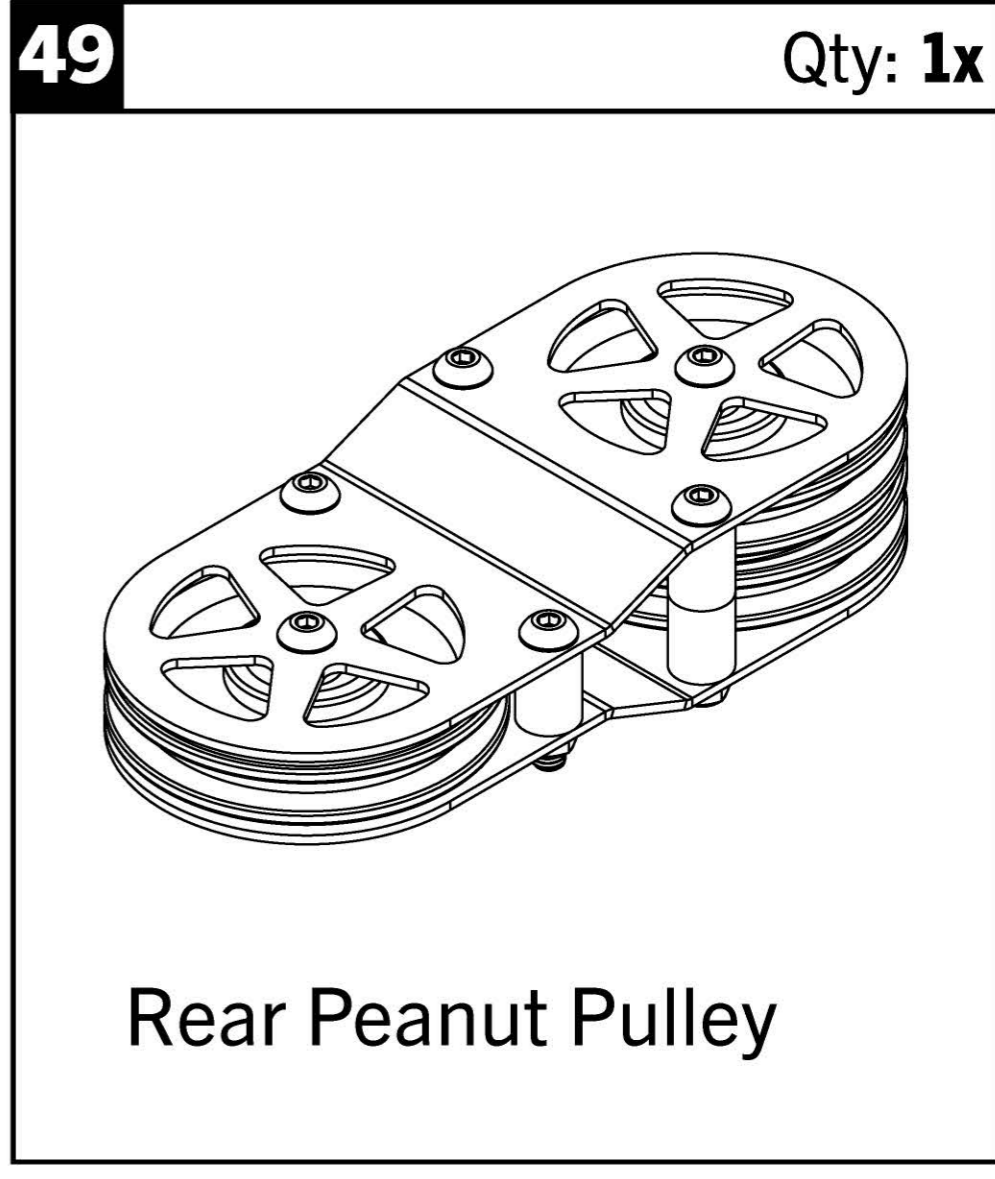
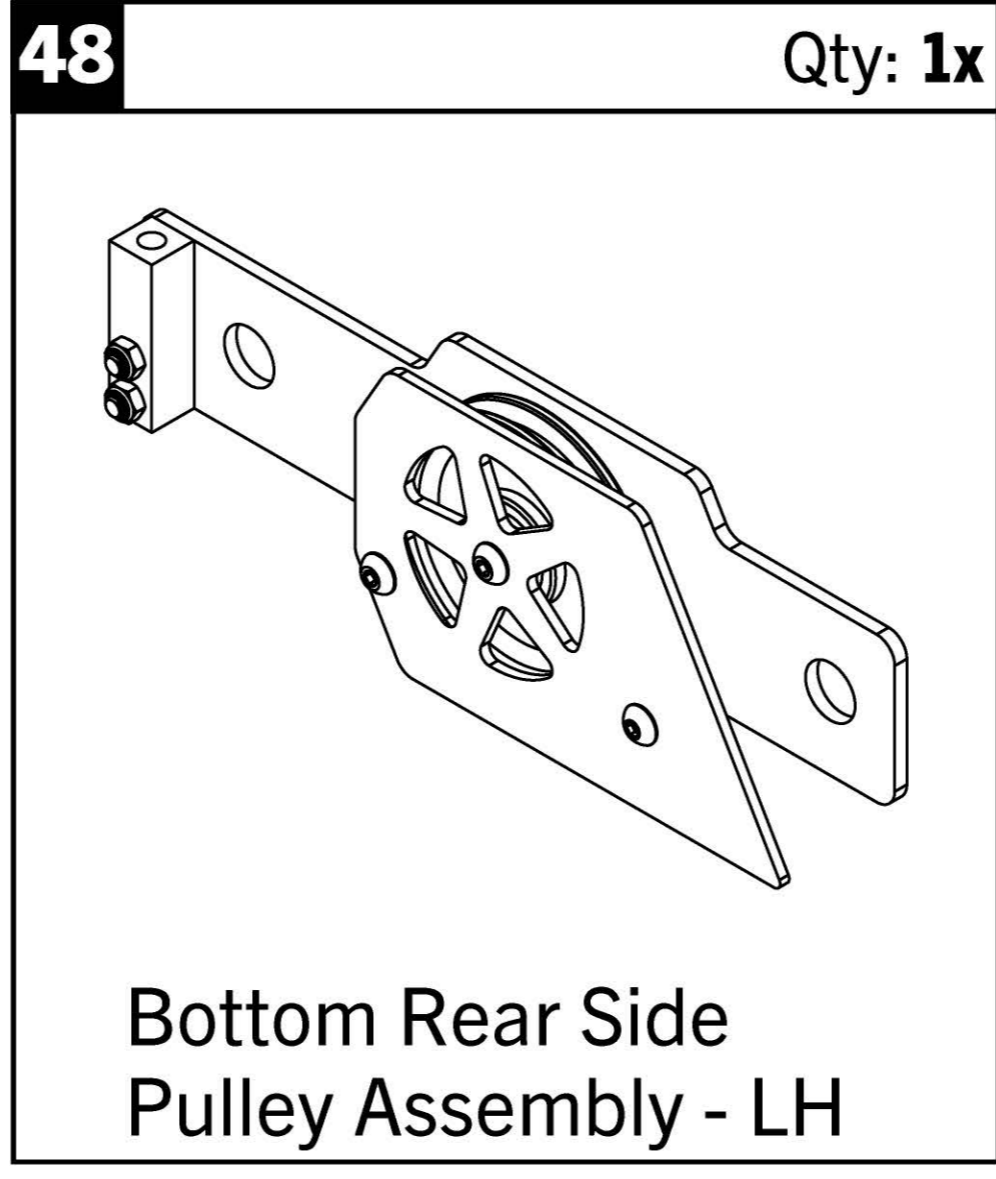
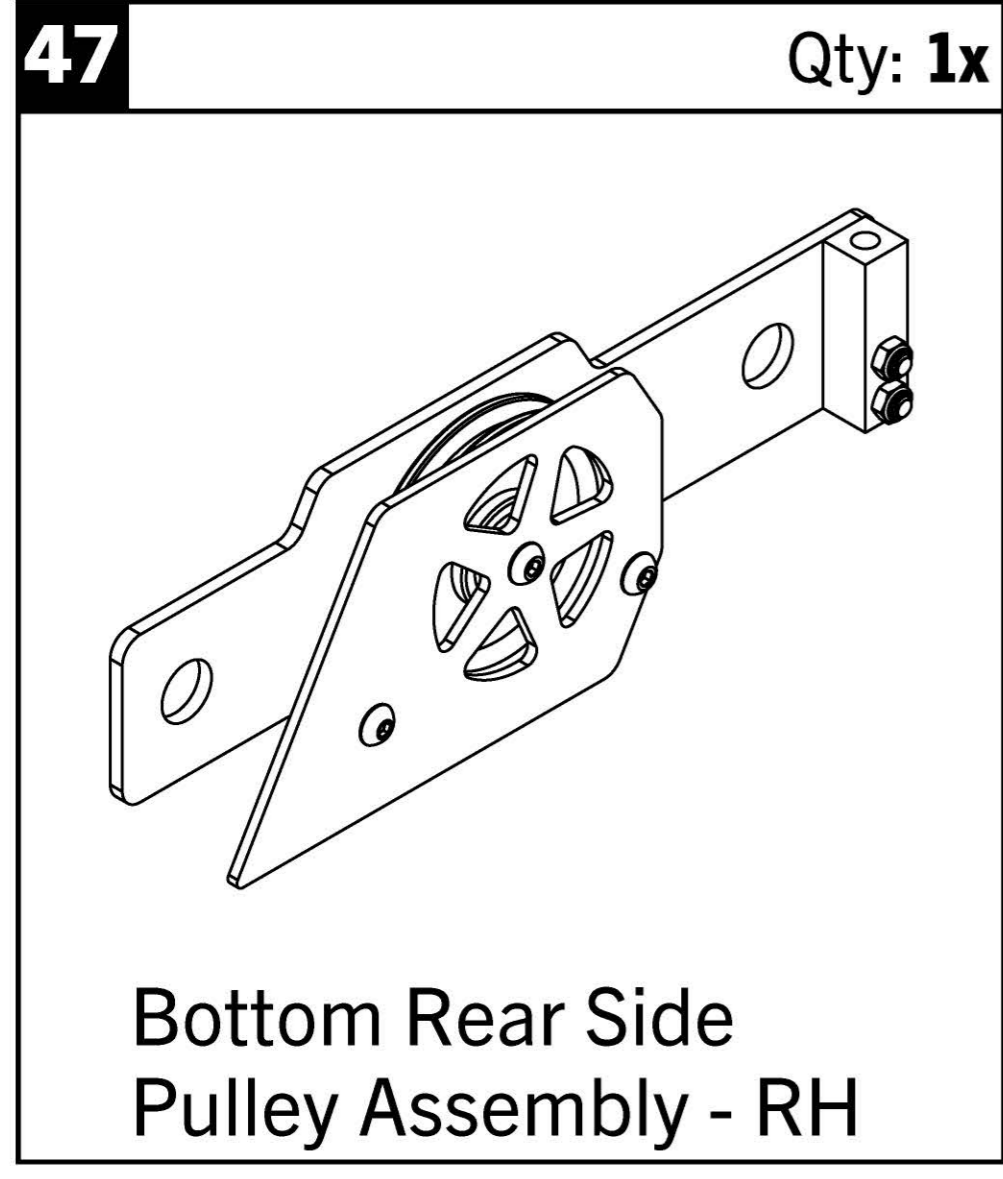
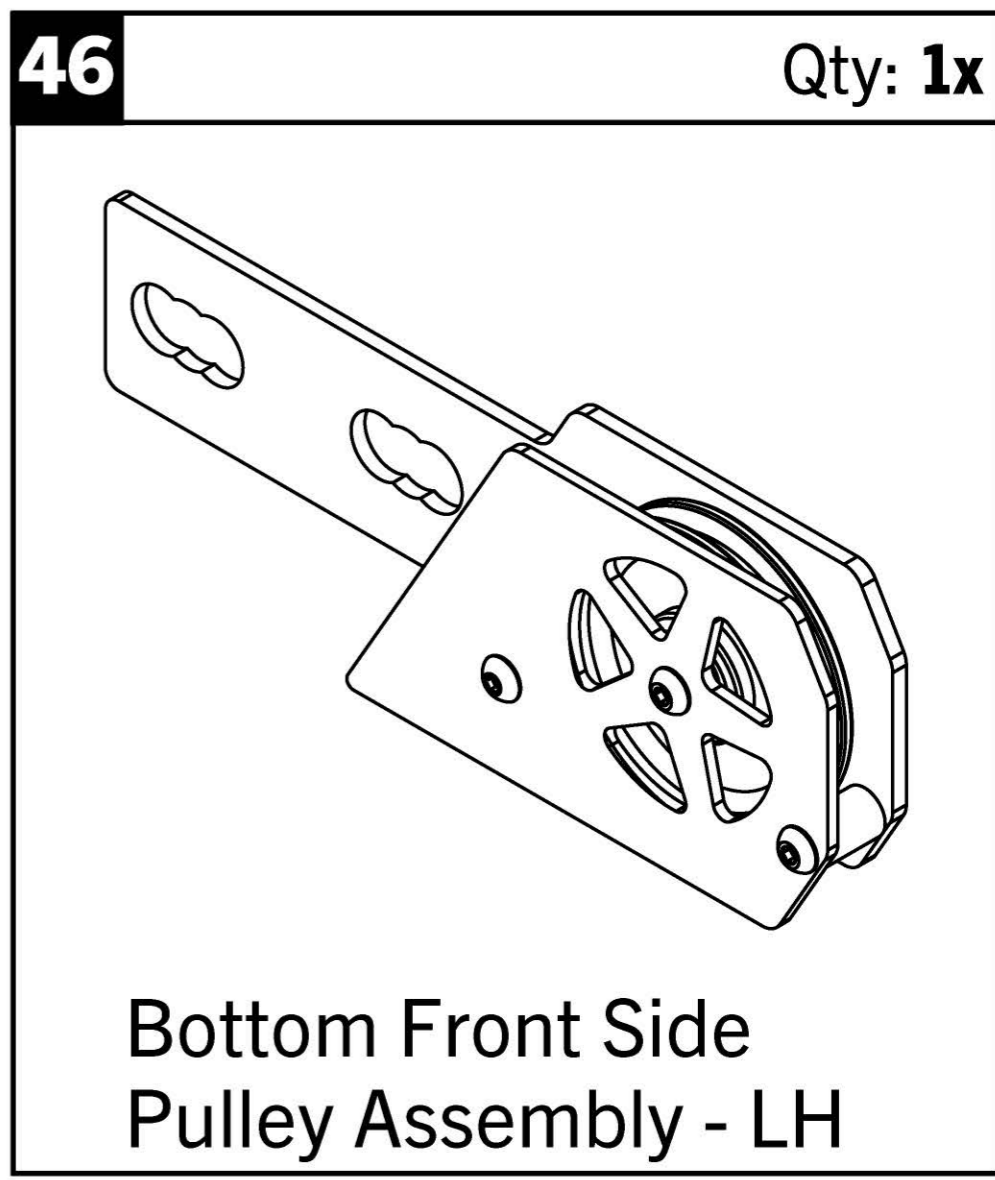
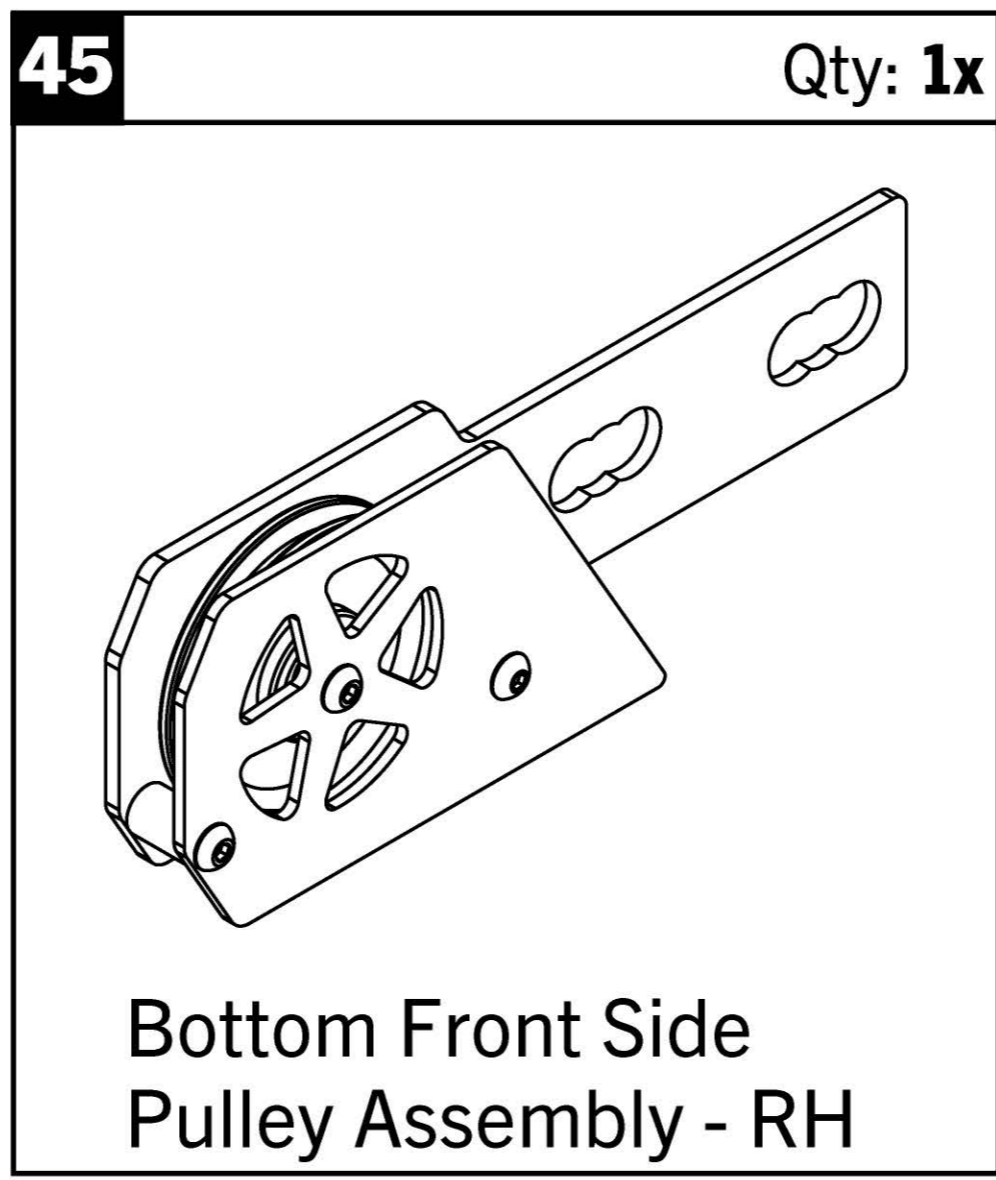
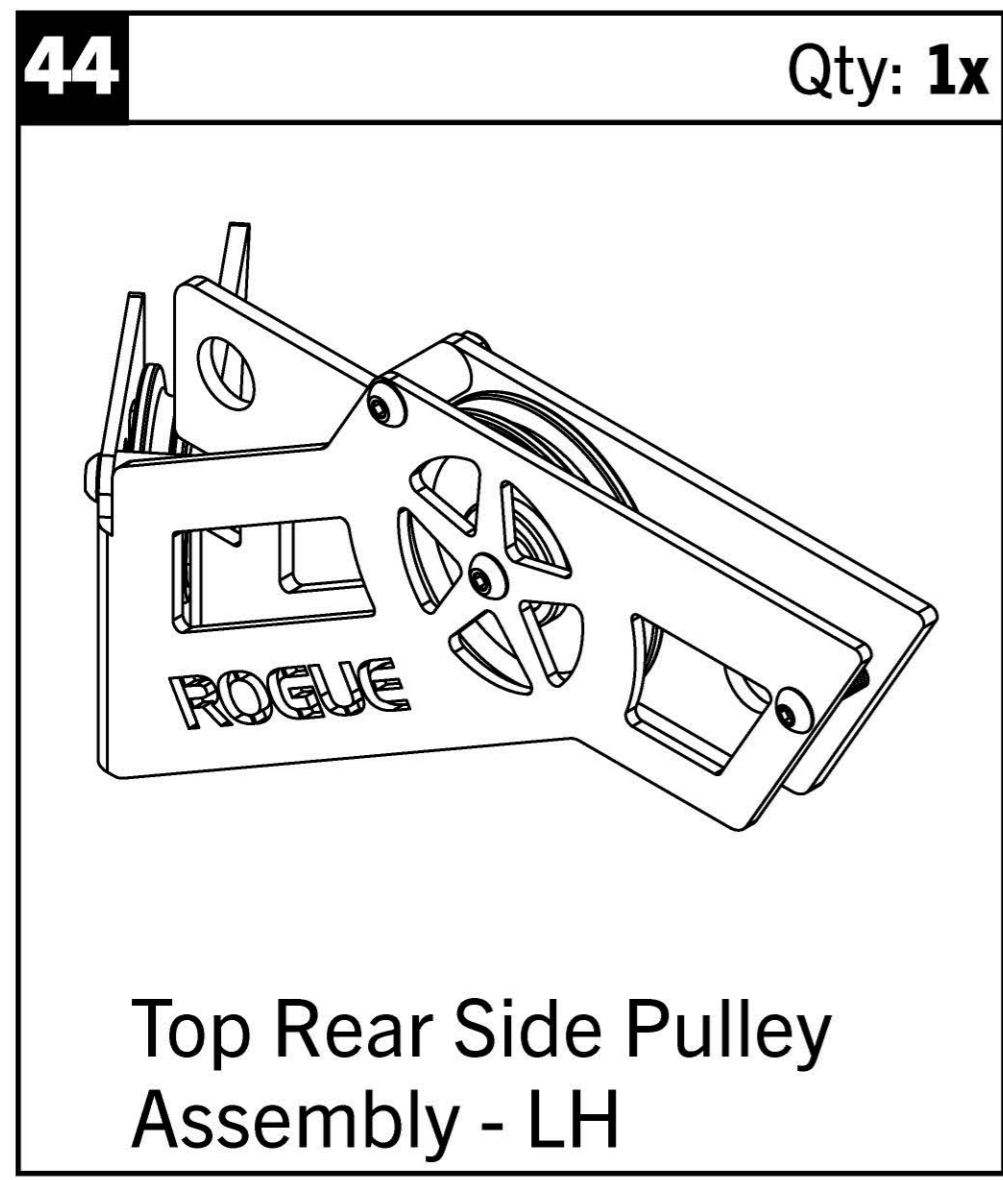
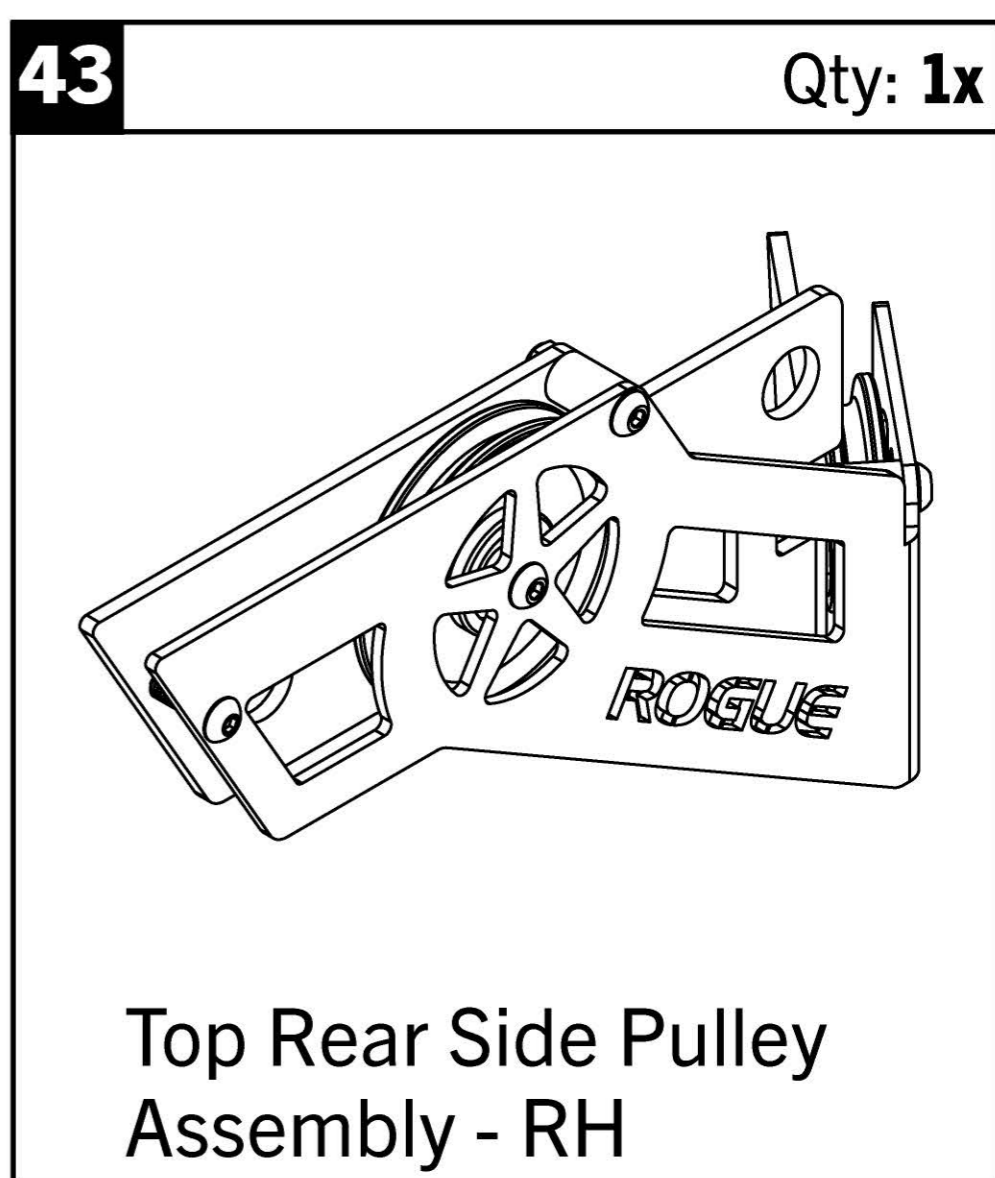
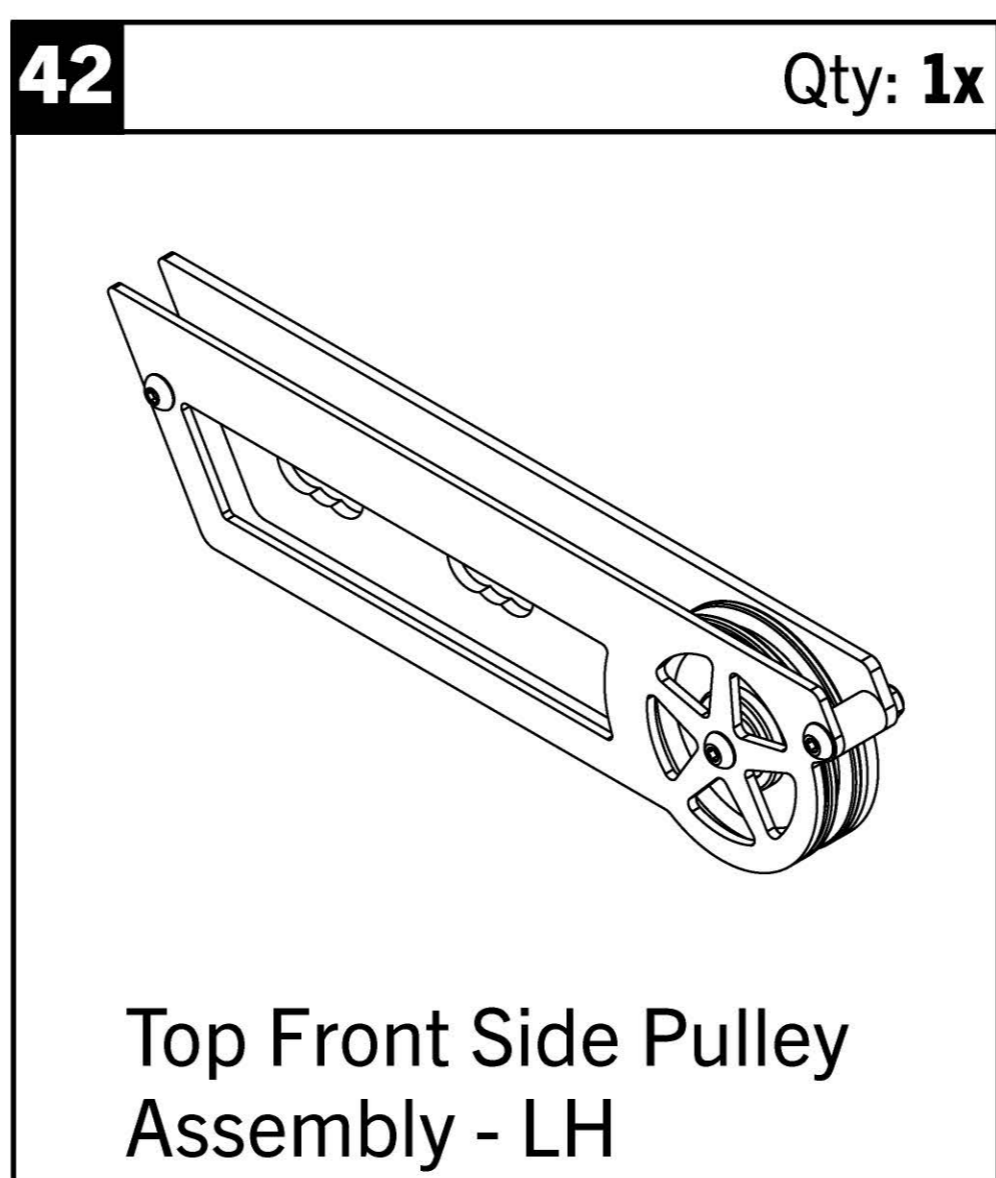
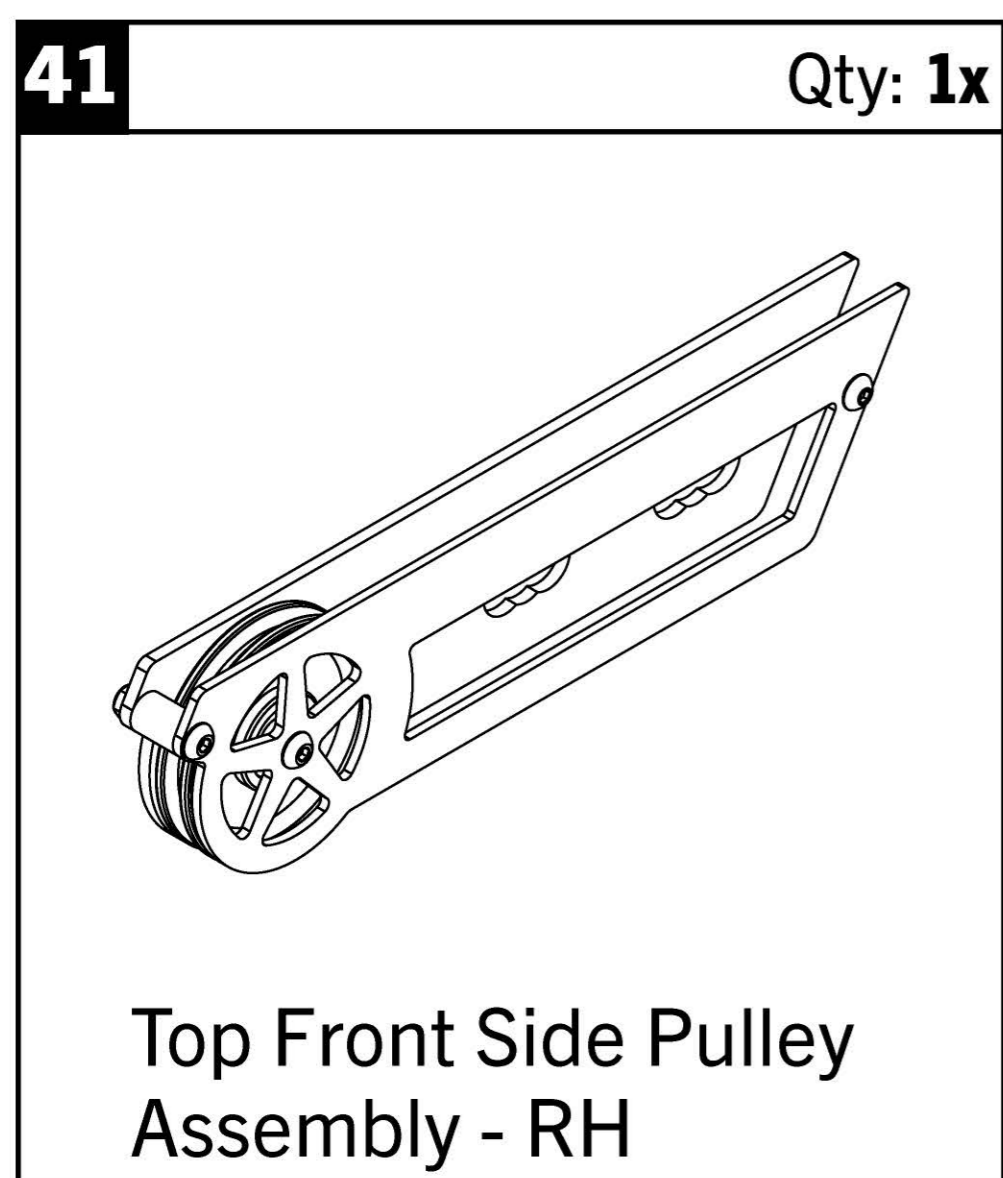



# INCLUDED PARTS: FM-6 ADD-ON KIT

Note: Images not shown at scale.

**53** Qty: **1x**

Trolley/Trolley Cable  
(Blue Tag)

**54** Qty: **1x**

\*

See Note\*

Lat Pull/Low Row Cable  
(Yellow Tag)

**55** Qty: **2x**

Low Side Cable  
(Red Tag)

**56** Qty: **1x**

20 LB. 9.10kg	30 LB. 13.6kg	40 LB. 18.2kg	50 LB. 22.7kg	60 LB. 27.2kg
70 LB. 31.8kg	80 LB. 36.4kg	90 LB. 40.9kg	100 LB. 45.5kg	110 LB. 50.5kg
120 LB. 54.5kg	130 LB. 59.1kg	140 LB. 63.6kg	150 LB. 68.2kg	160 LB. 72.7kg
170 LB. 77.3kg	180 LB. 81.8kg	190 LB. 86.4kg	200 LB. 90.9kg	210 LB. 95.5kg
220 LB. 100kg	230 LB. 104.5kg	240 LB. 109.1kg	250 LB. 113.6kg	260 LB. 118.2kg
270 LB. 122.7kg	280 LB. 127.3kg	290 LB. 131.8kg	300 LB. 136.4kg	

Weight Stack Number  
Label Sheet

**57** Qty: **8x**

Plate Storage Spacer

**58** Qty: **1x**

Stainless Lat Bar

**59** Qty: **1x**

Standard Grip Triangle

**60** Qty: **2x**

Single Handle Cable Attachment

**61** Qty: **2x**

D Carabiner

**62** Qty: **2x**

1" Shoulder Bolt -  
Female

**63** Qty: **2x**

1" Shoulder Bolt - Male

**64** Qty: **20x**

1" x 5" Hex Bolt

\* Extra "retainer" hardware shown is not included on Lat Pull/Low Row Cable for 90" Racks.

# INCLUDED PARTS: FM-6 ADD-ON KIT

Note: Images not shown at scale.

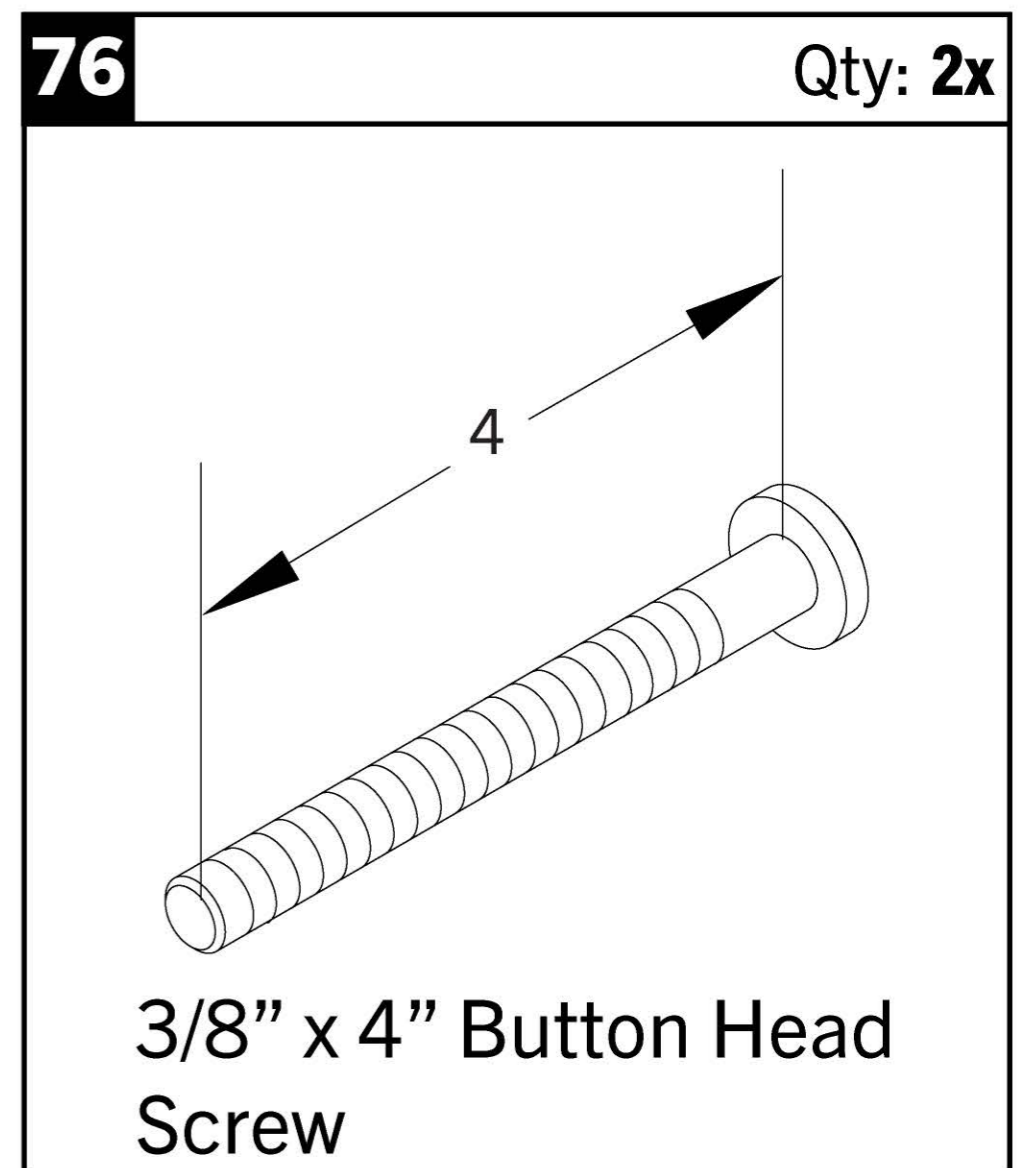
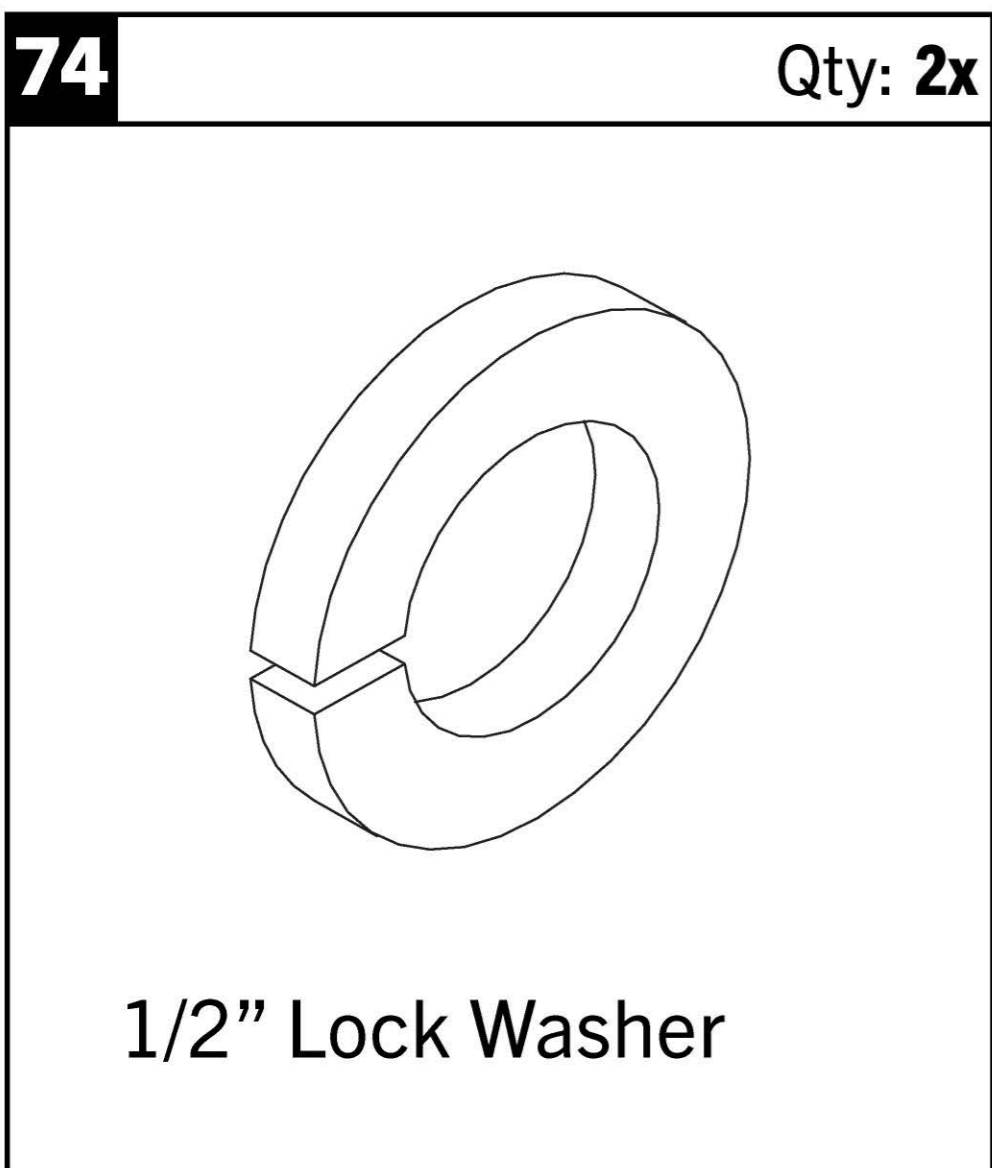
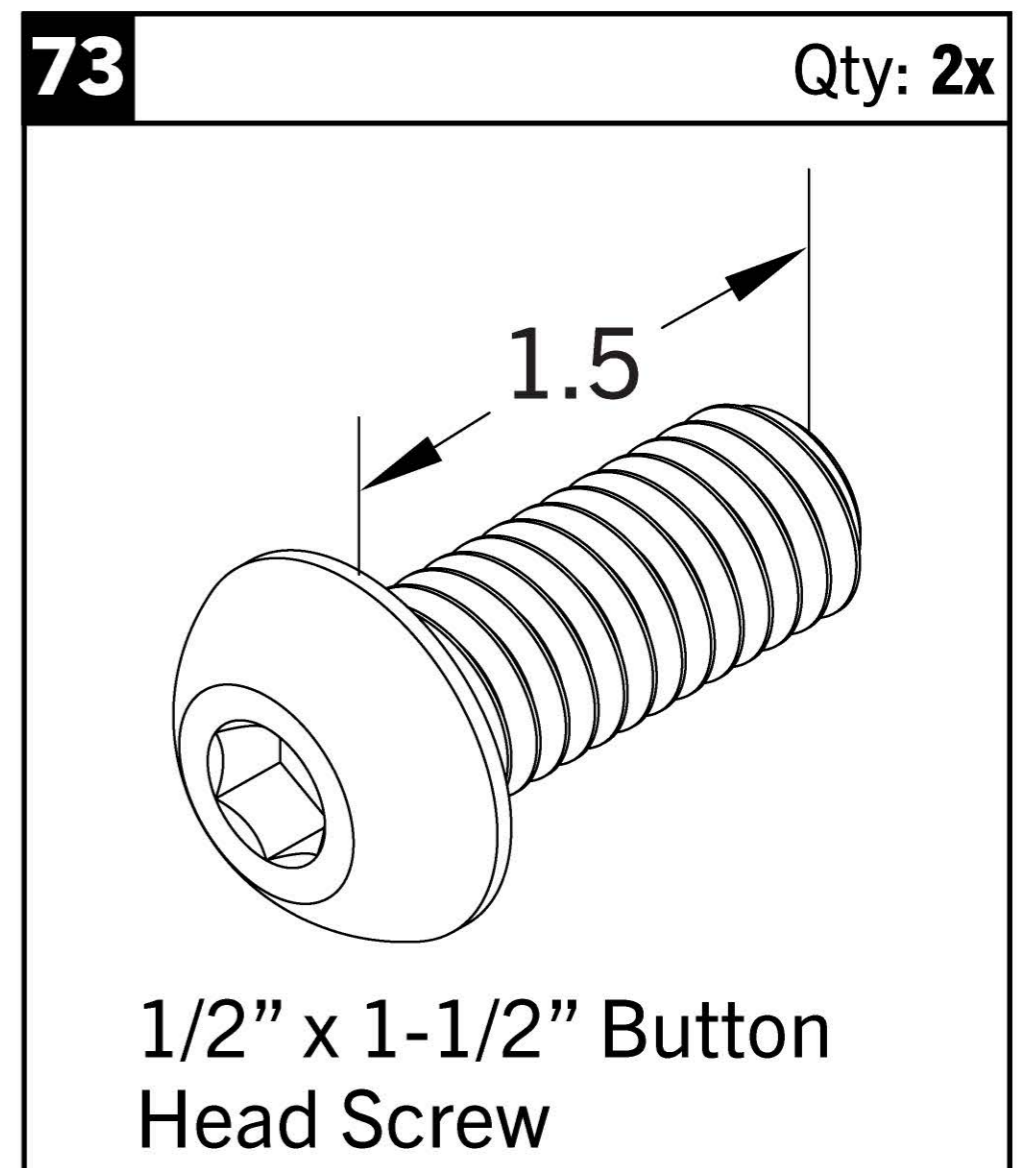
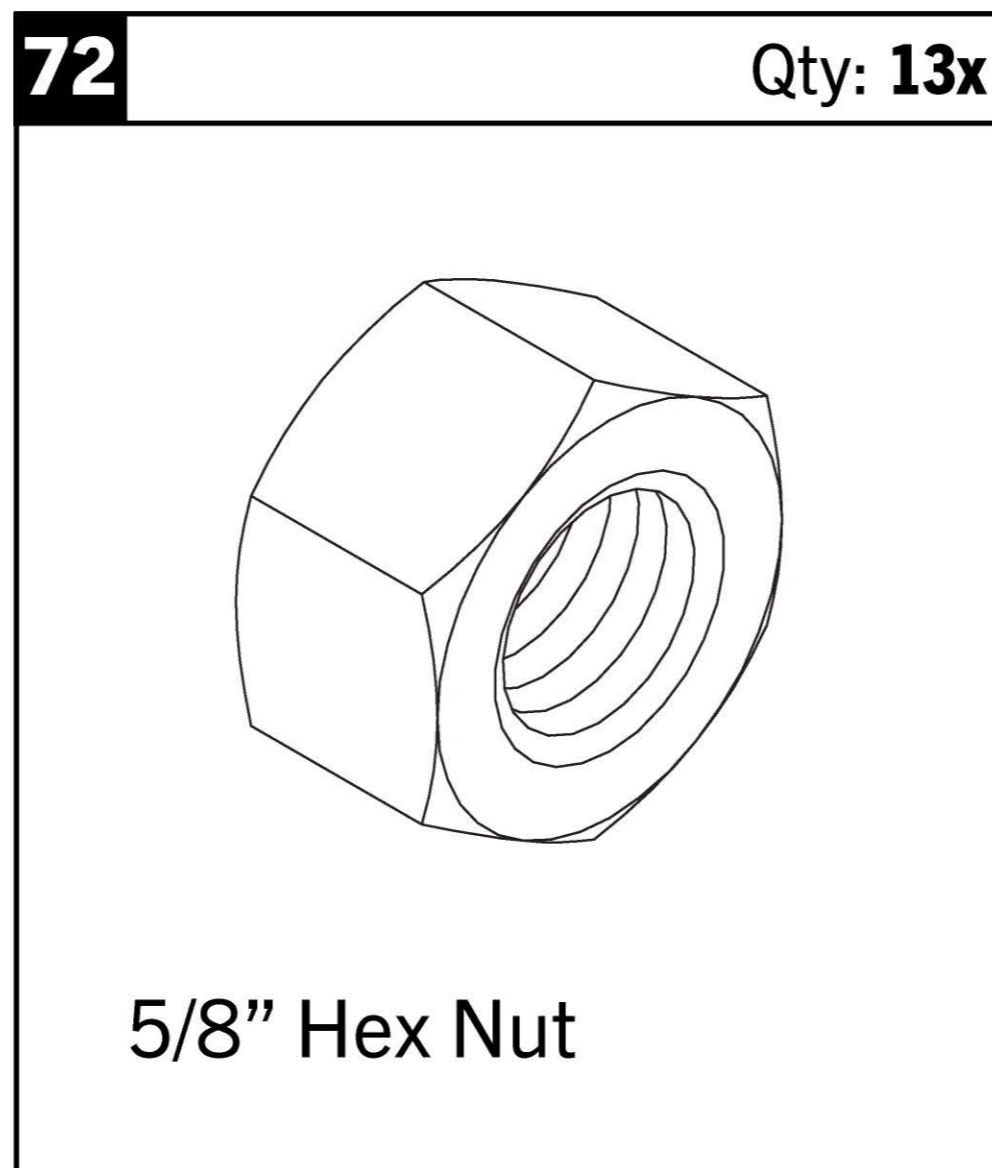
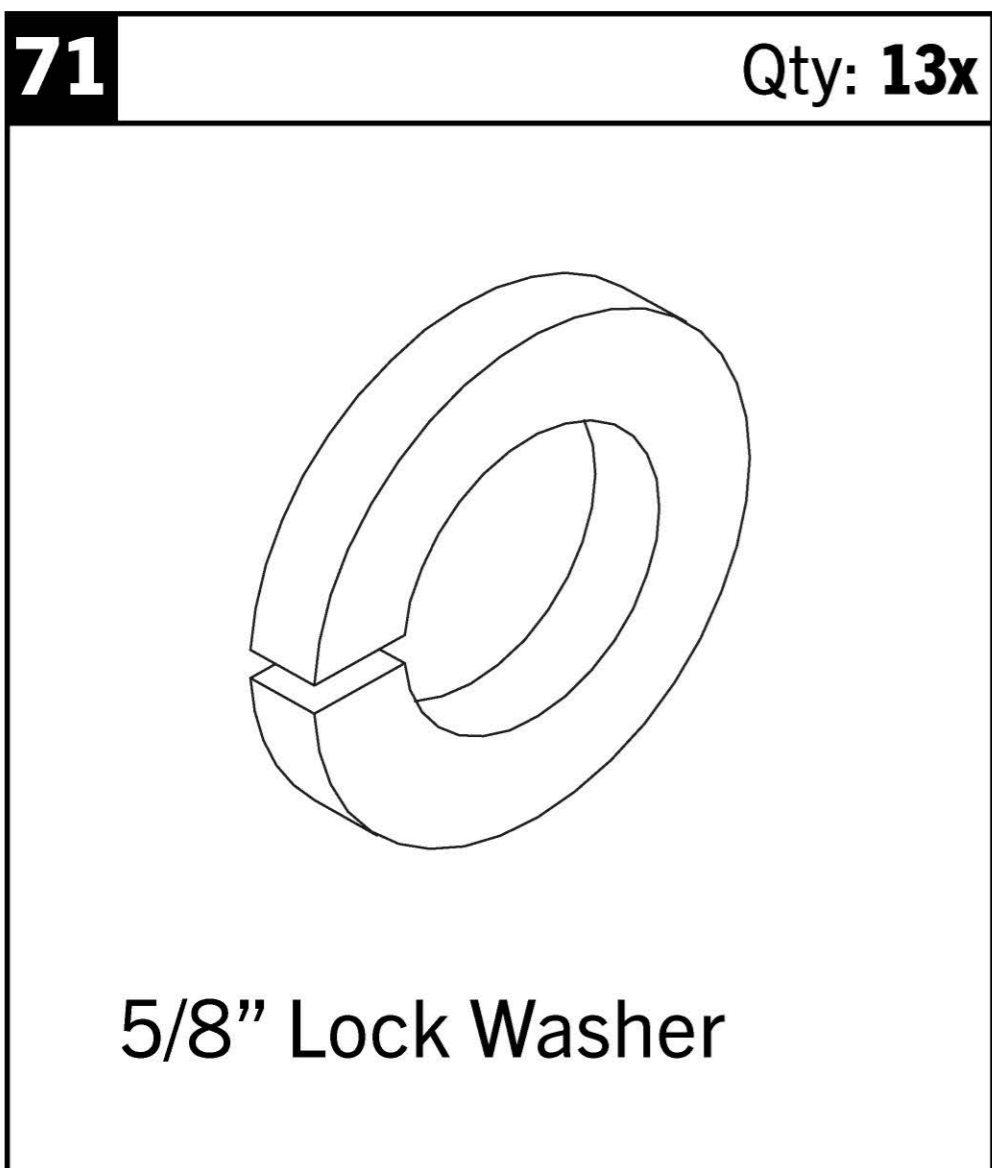
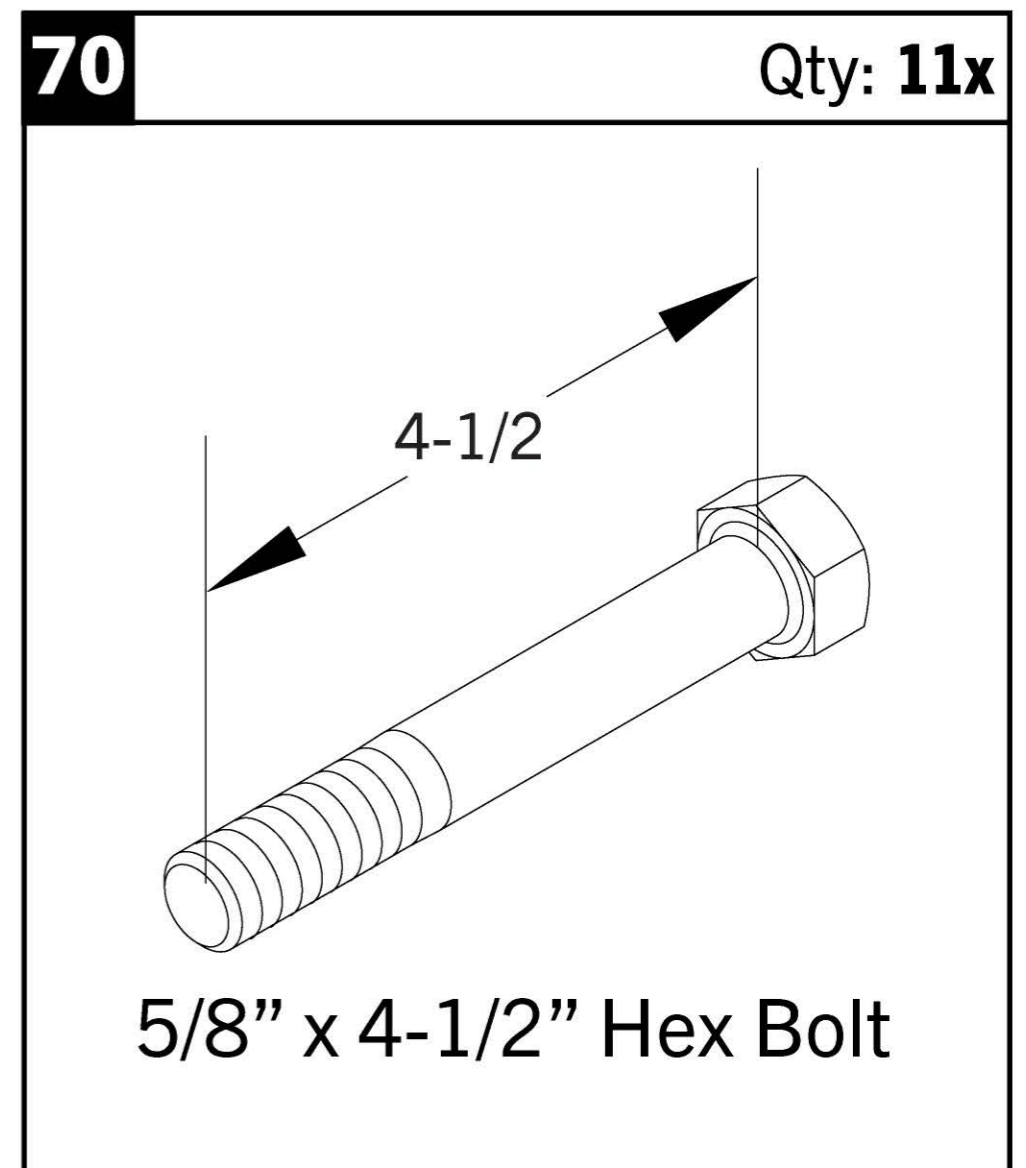
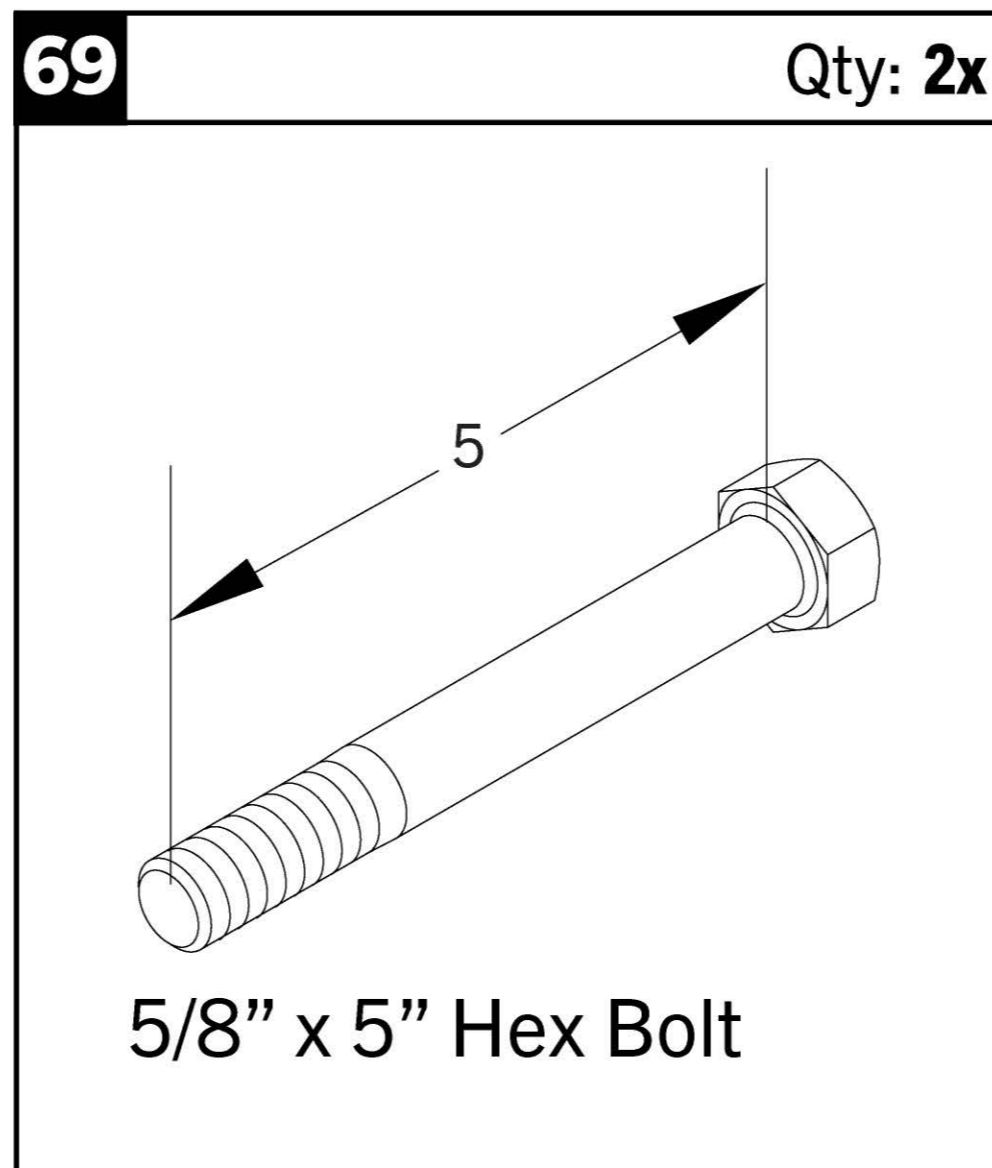
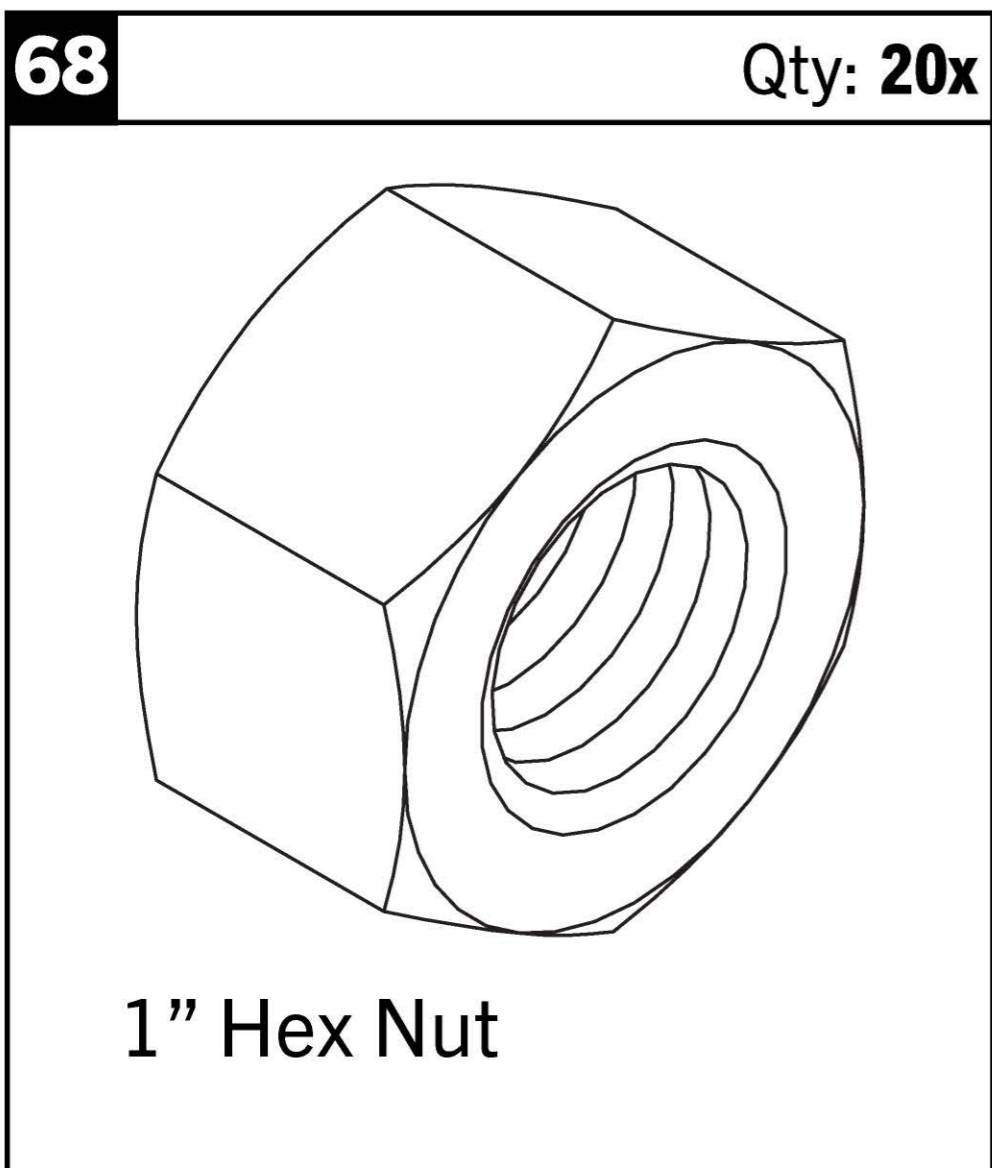
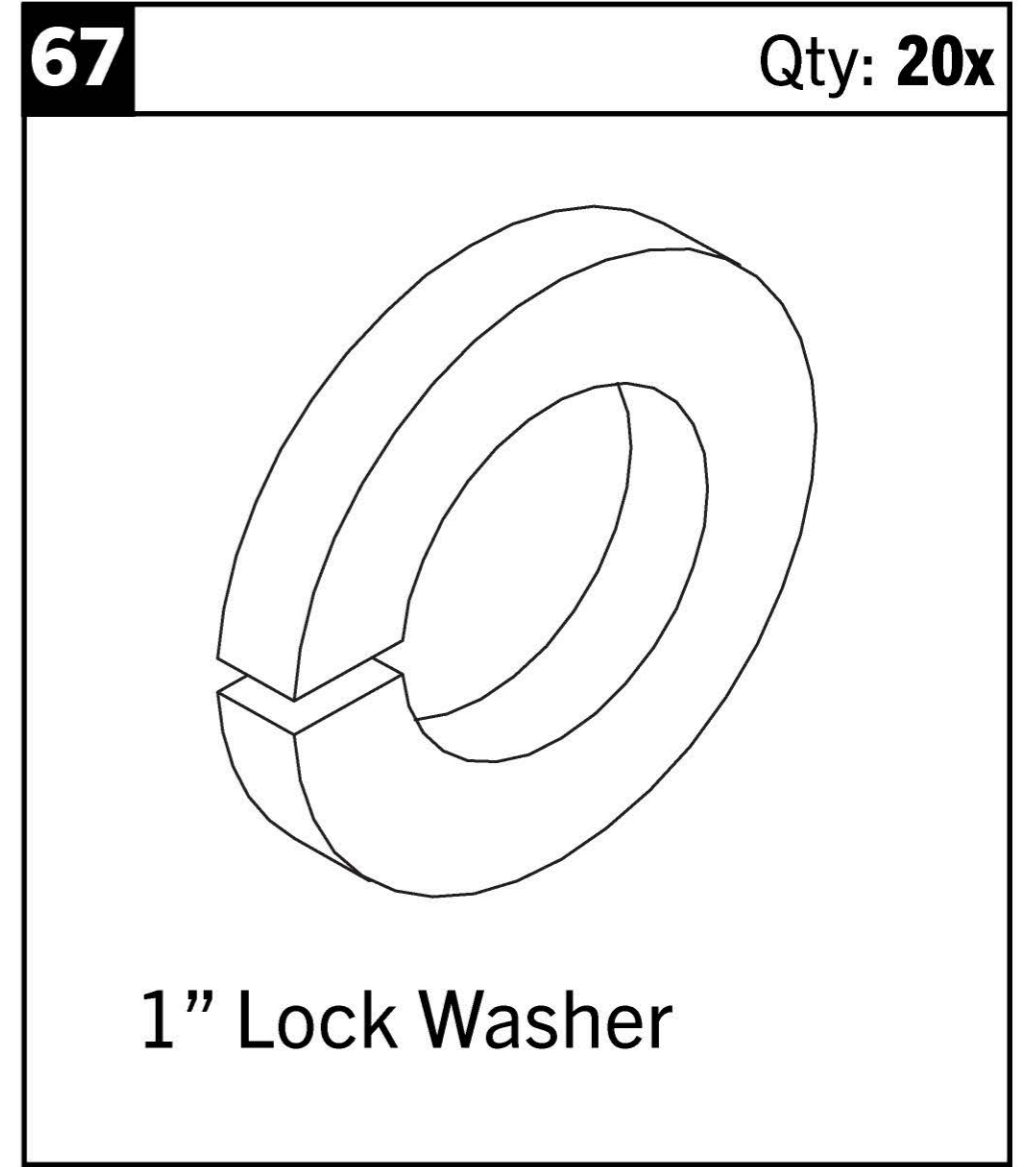
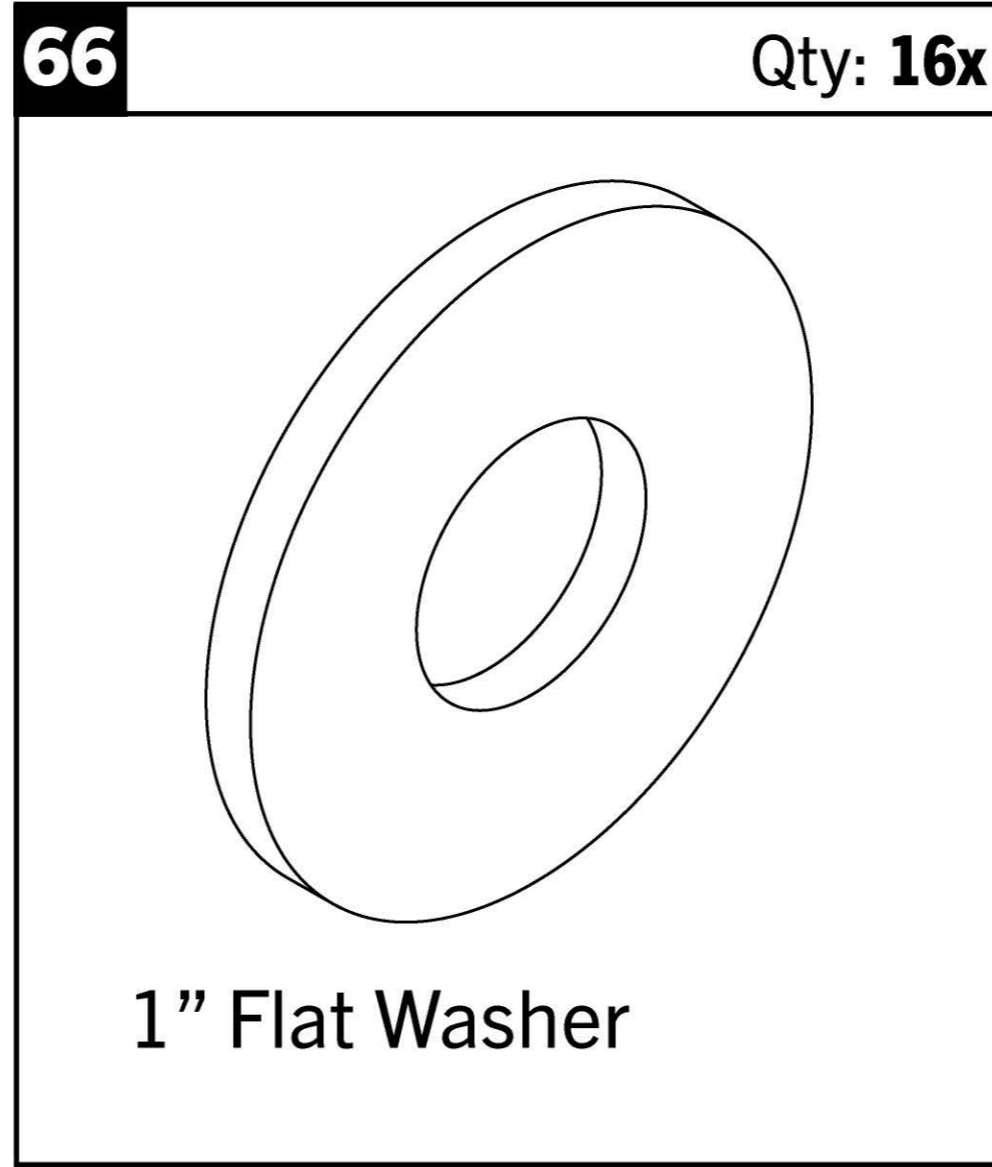
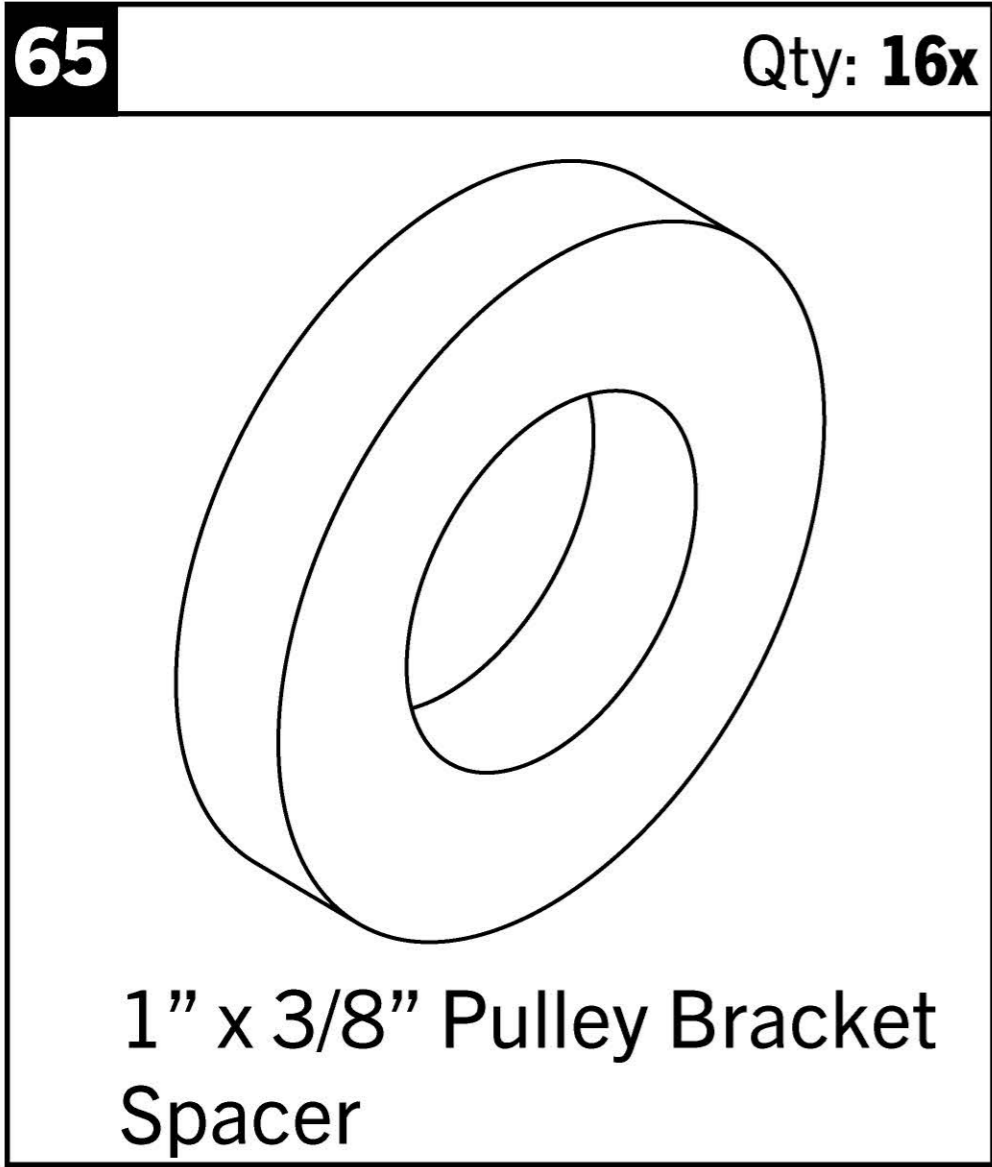

# INCLUDED PARTS: FM-6 ADD-ON KIT

Note: Images not shown at scale.

**77**

Qty: **4x**

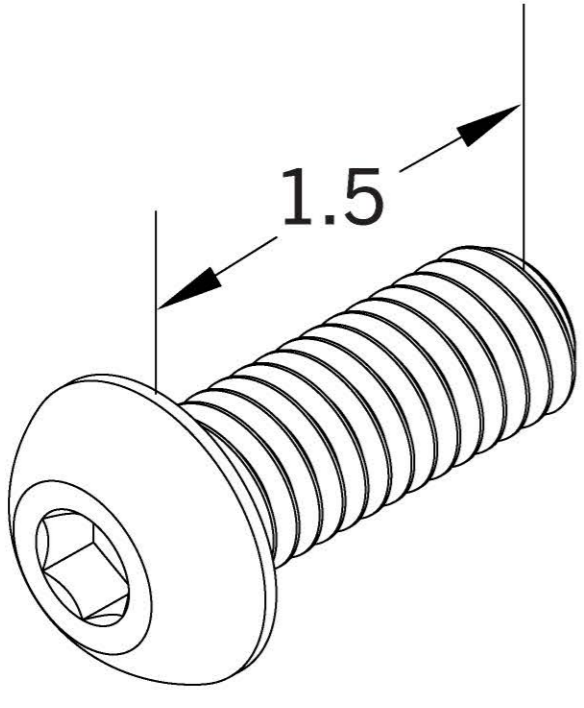

3/8" x 1.5" Button  
Head Screw

**78**

Qty: **6x**

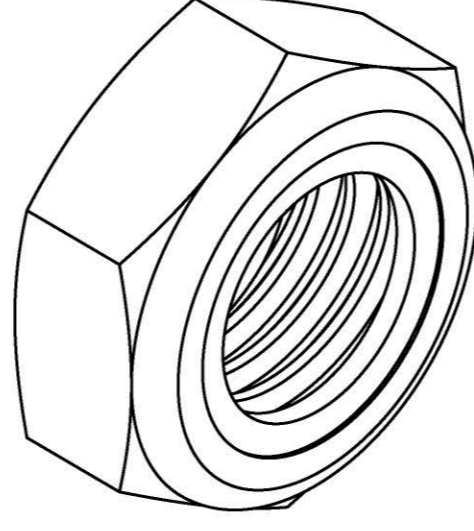

3/8" Thin Nylock Nut

# INCLUDED PARTS: SHROUD KIT

Note: Images not shown at scale.

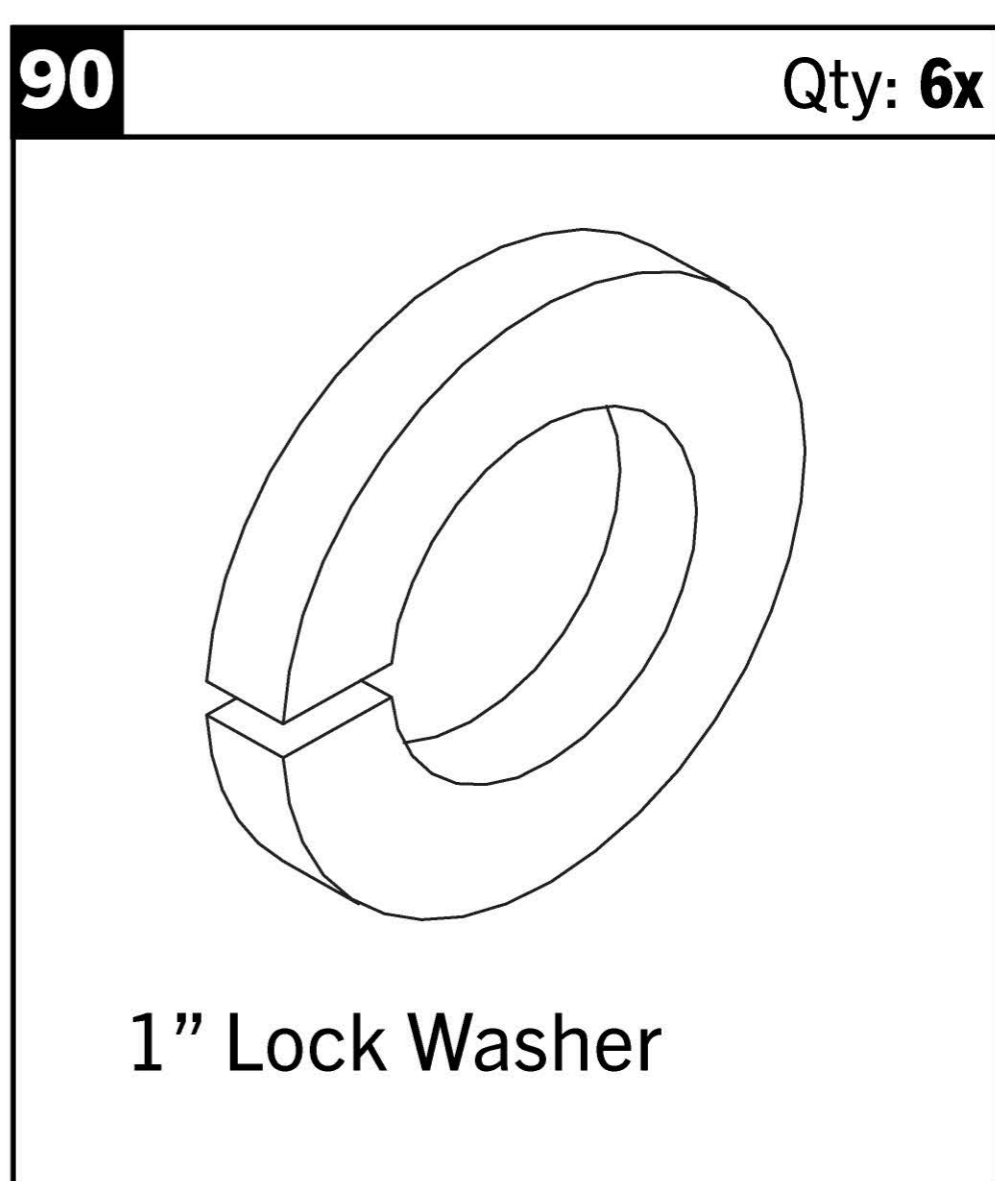
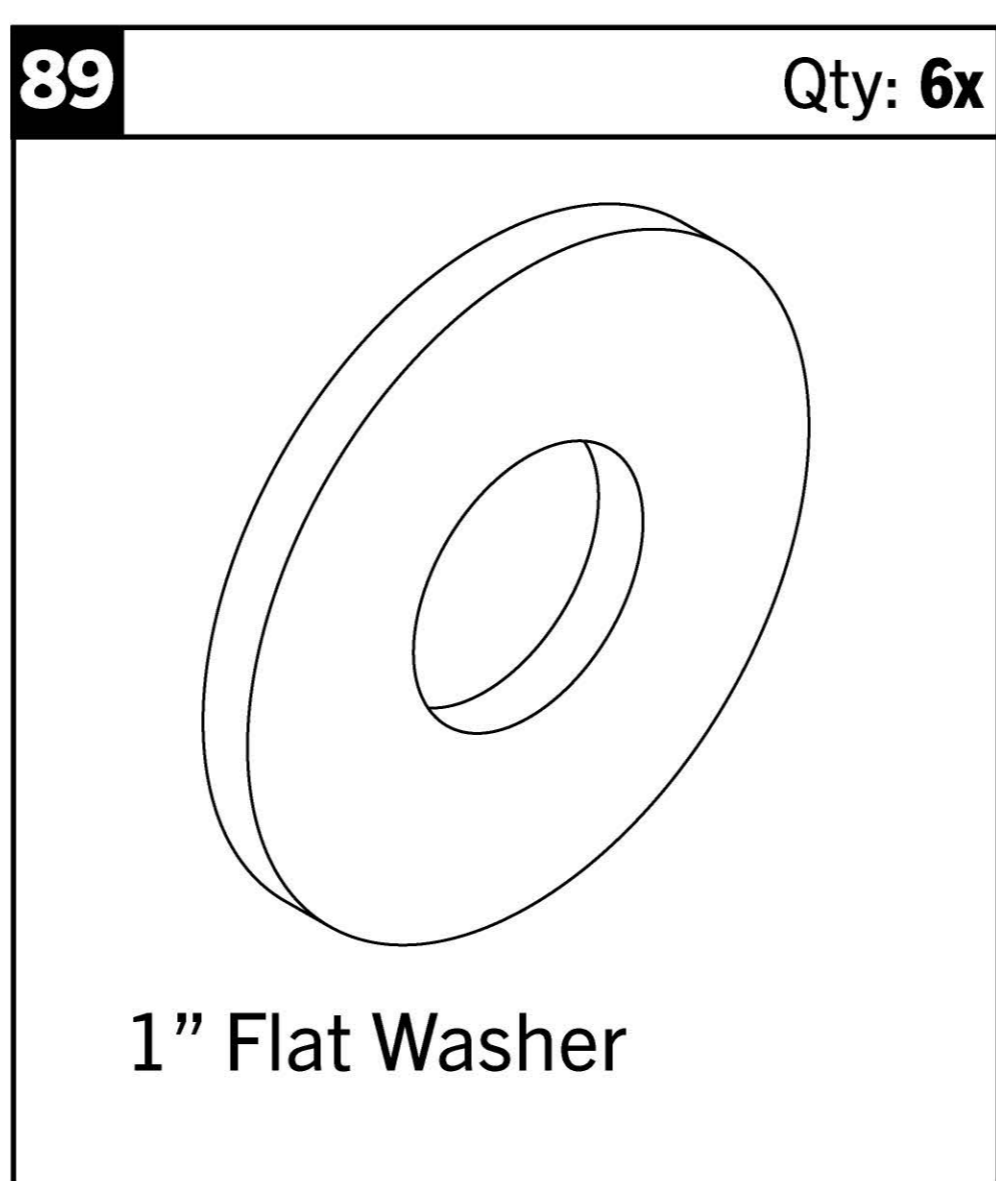
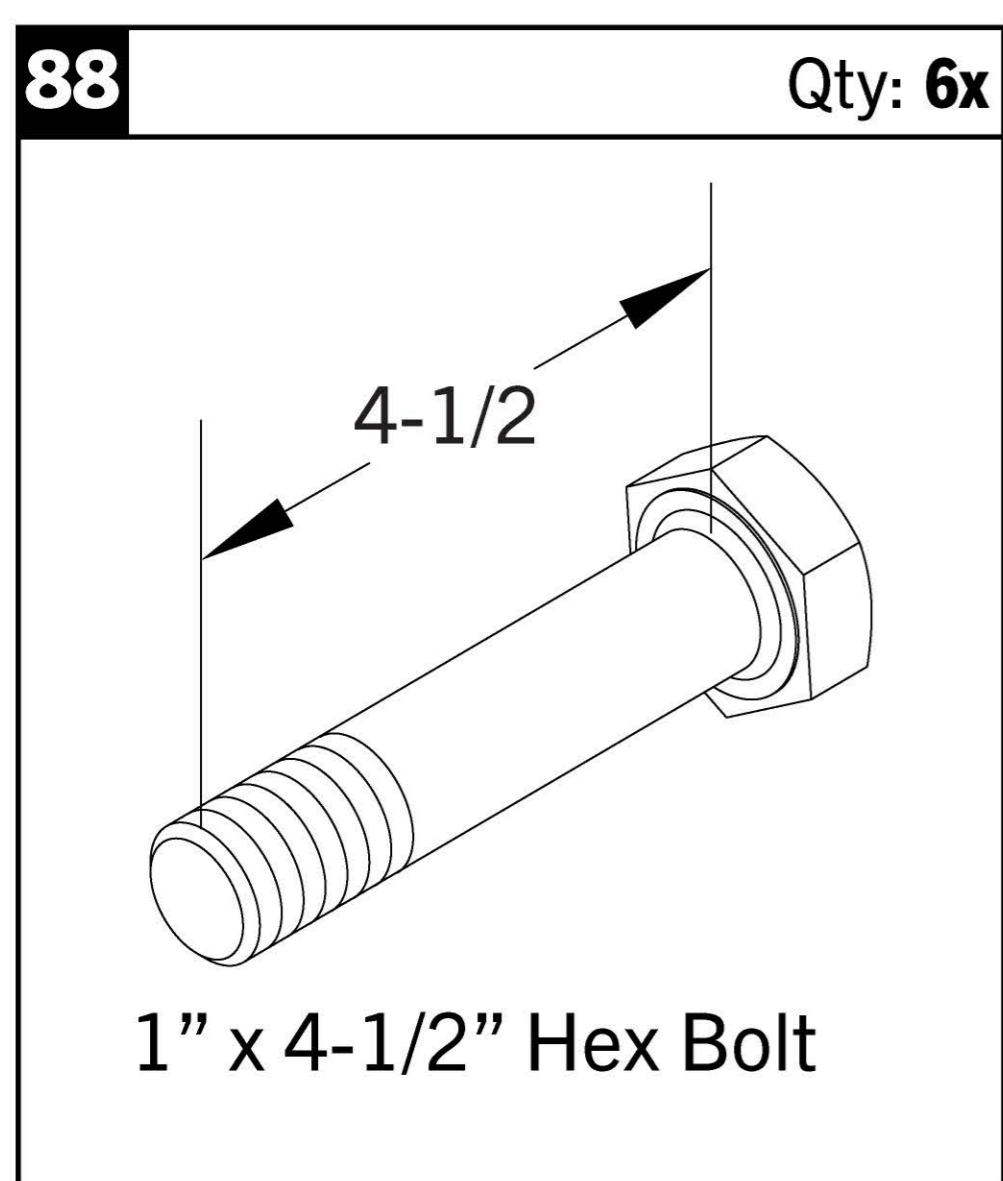
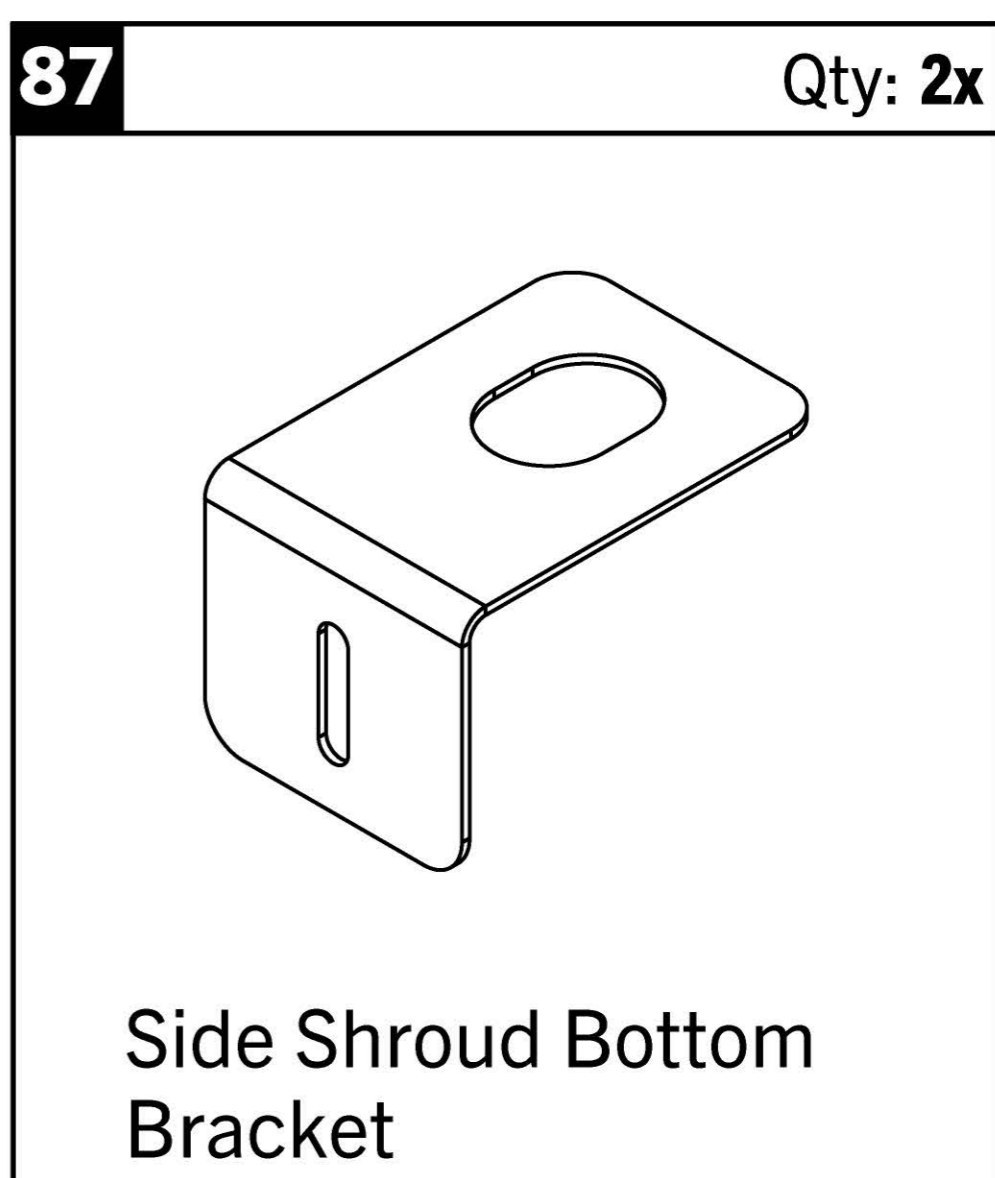
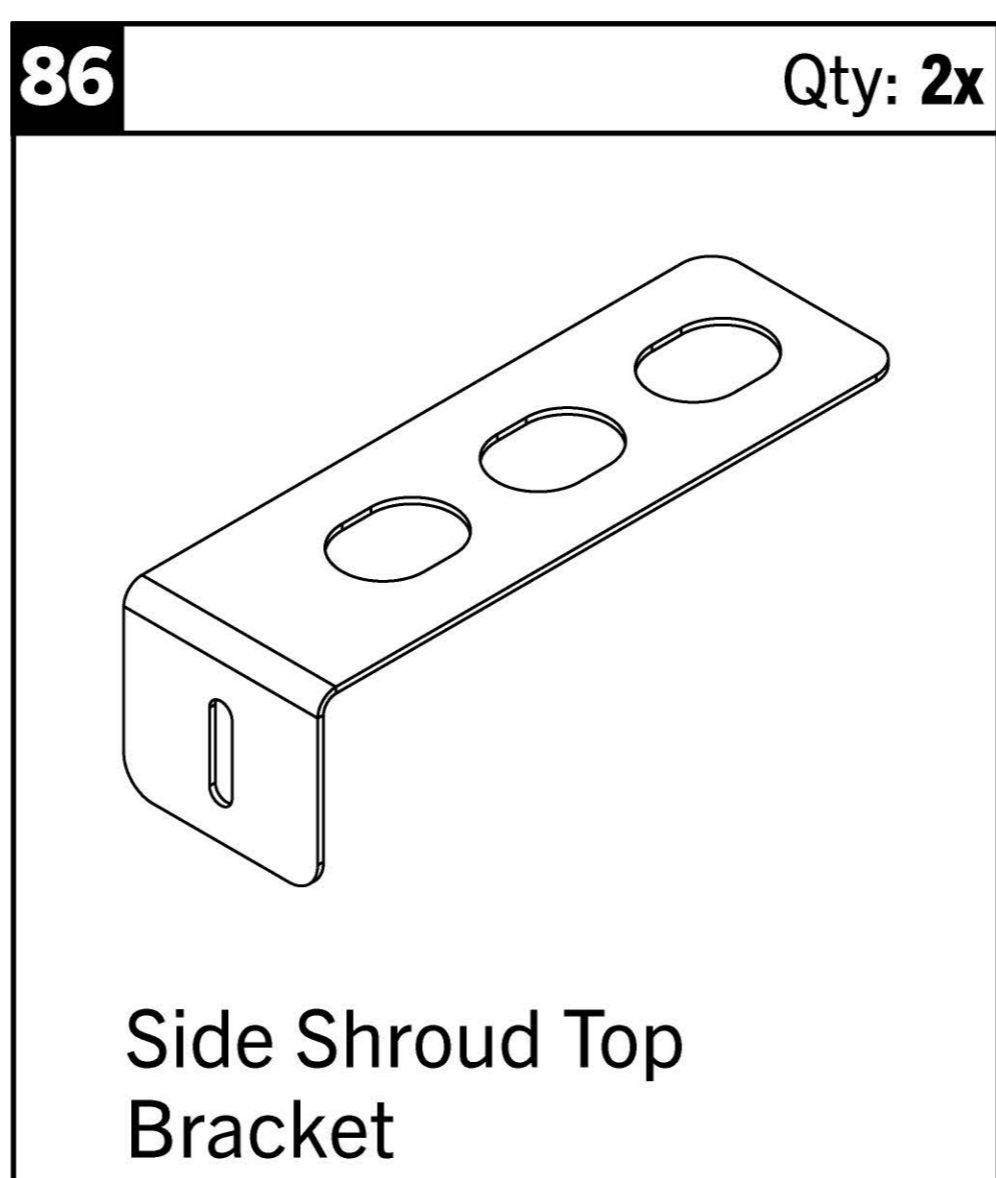
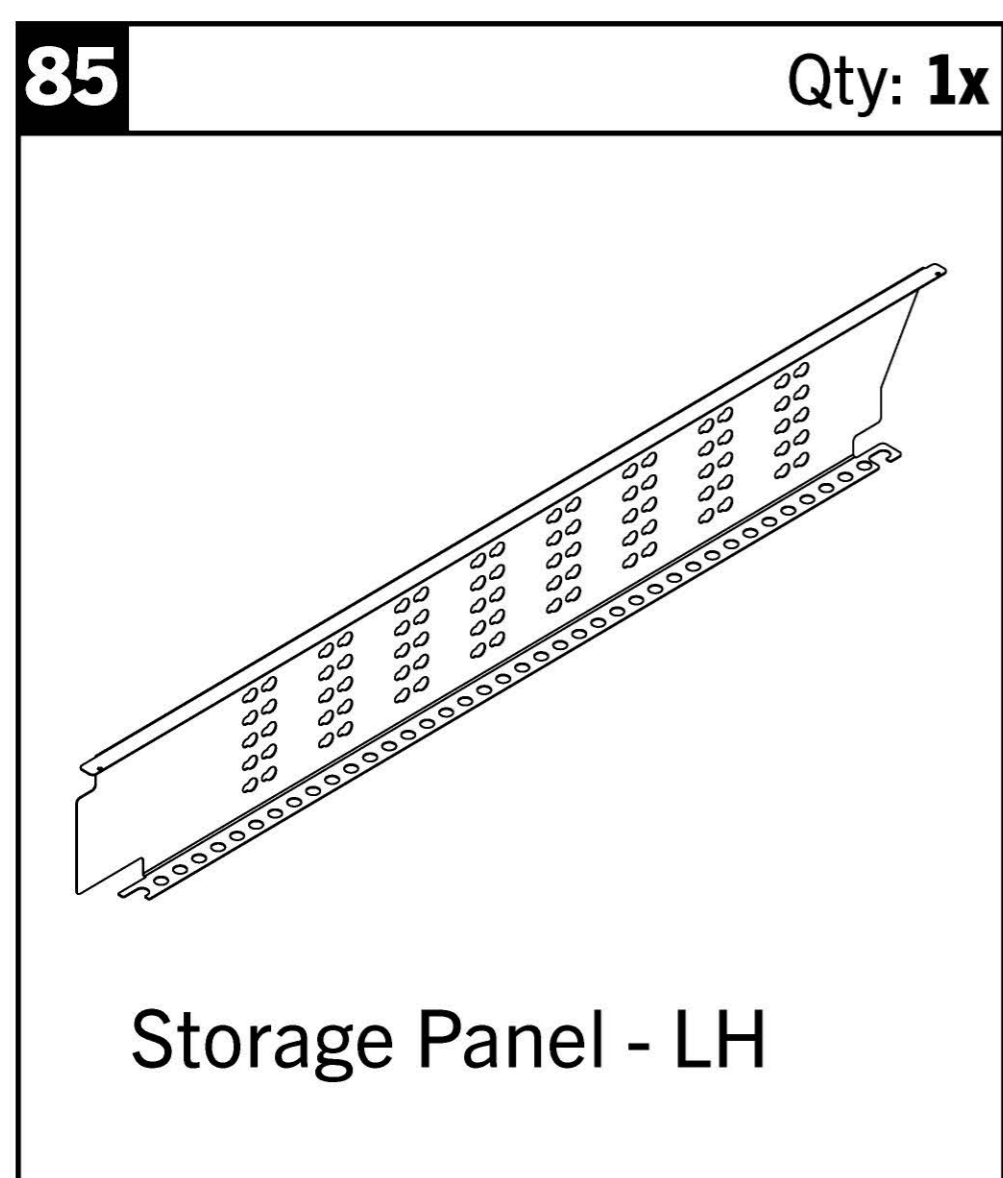
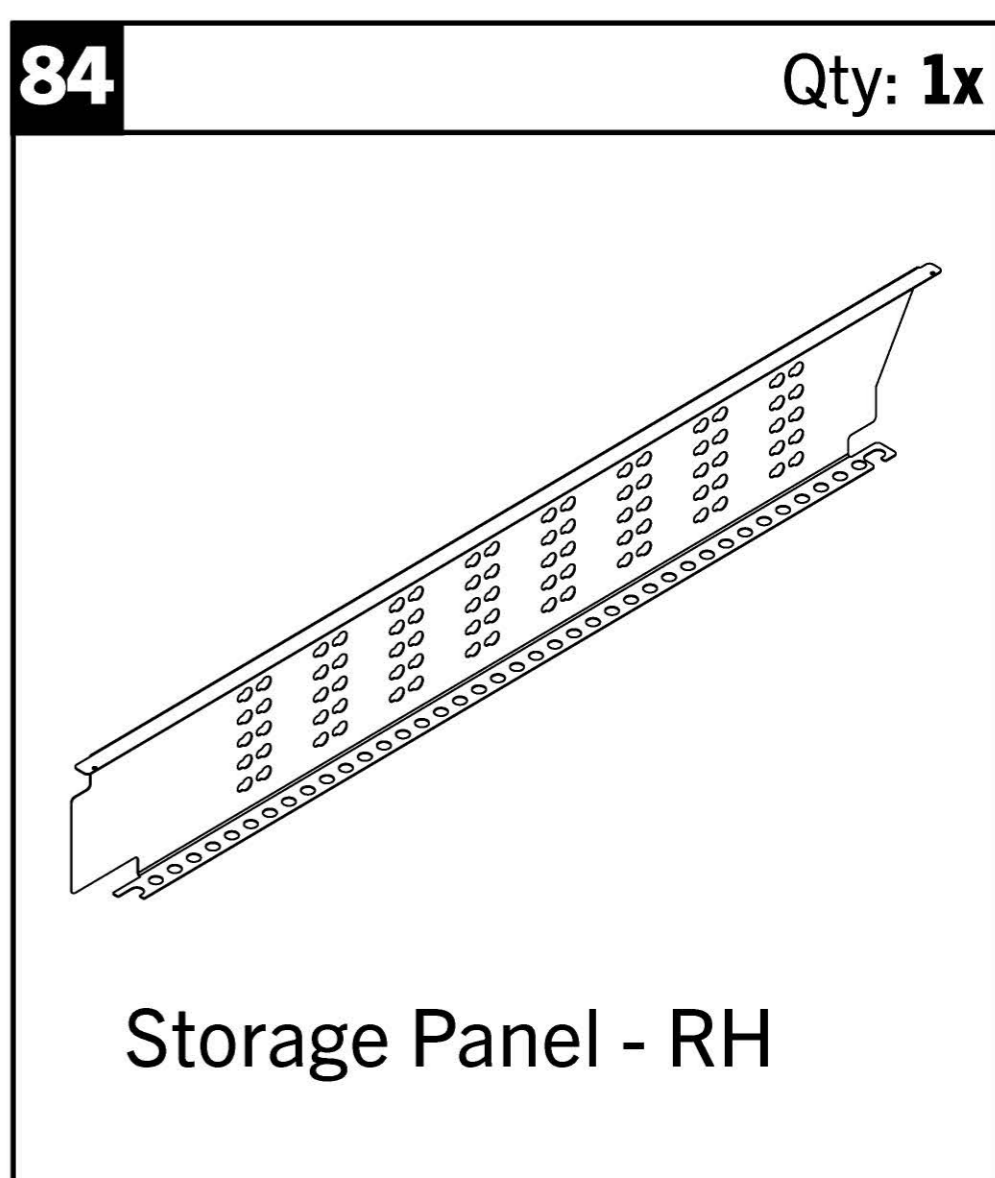
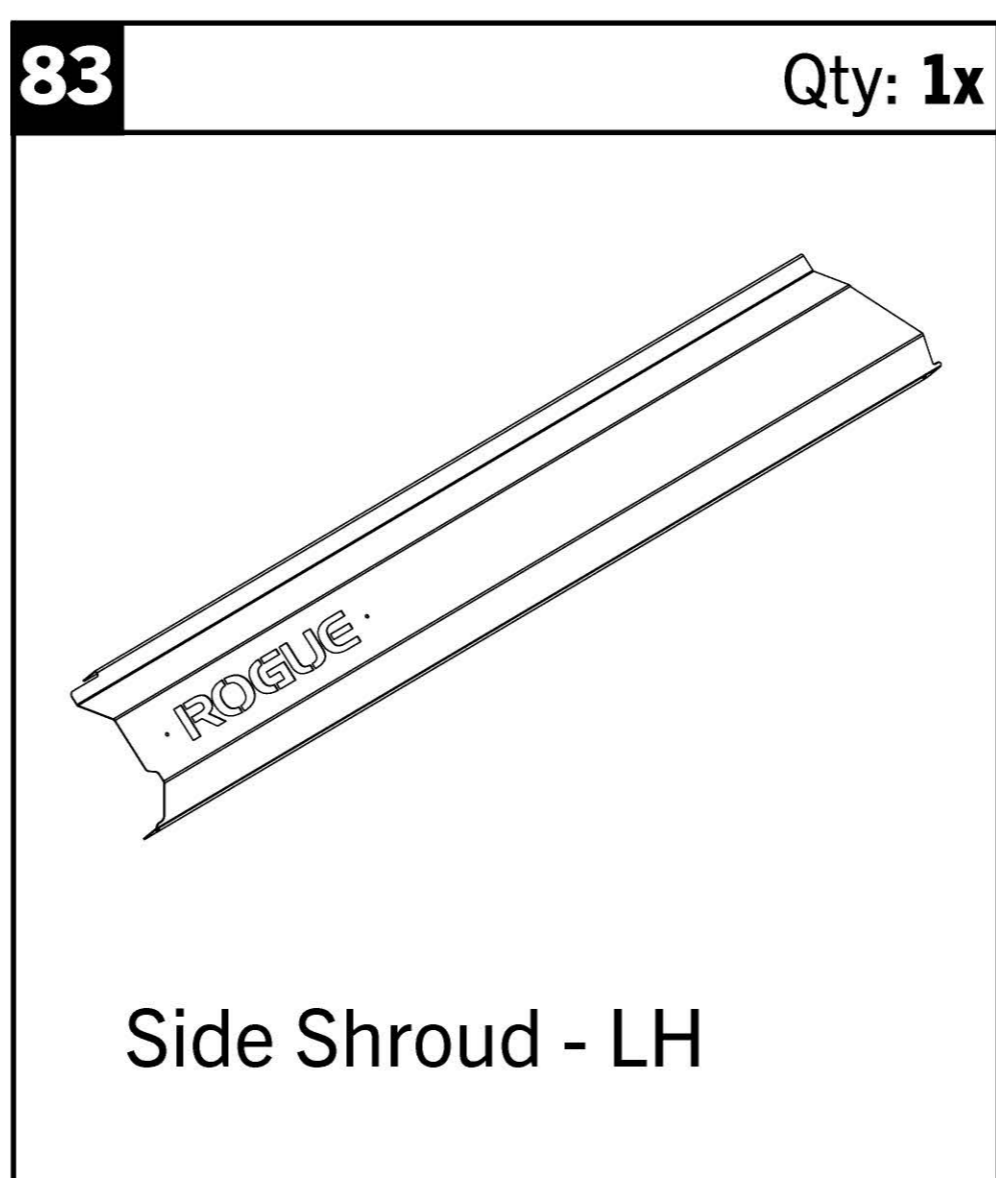
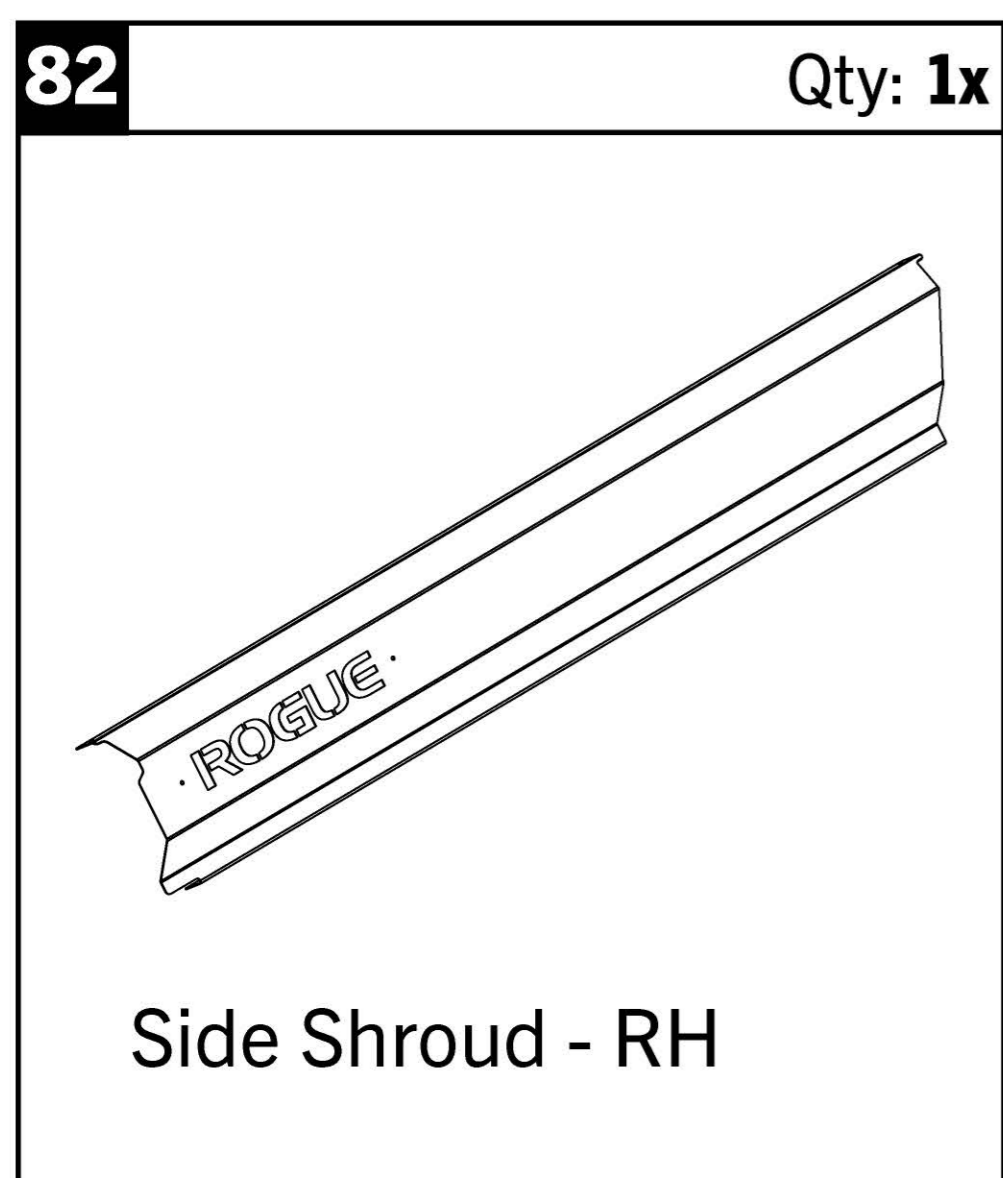
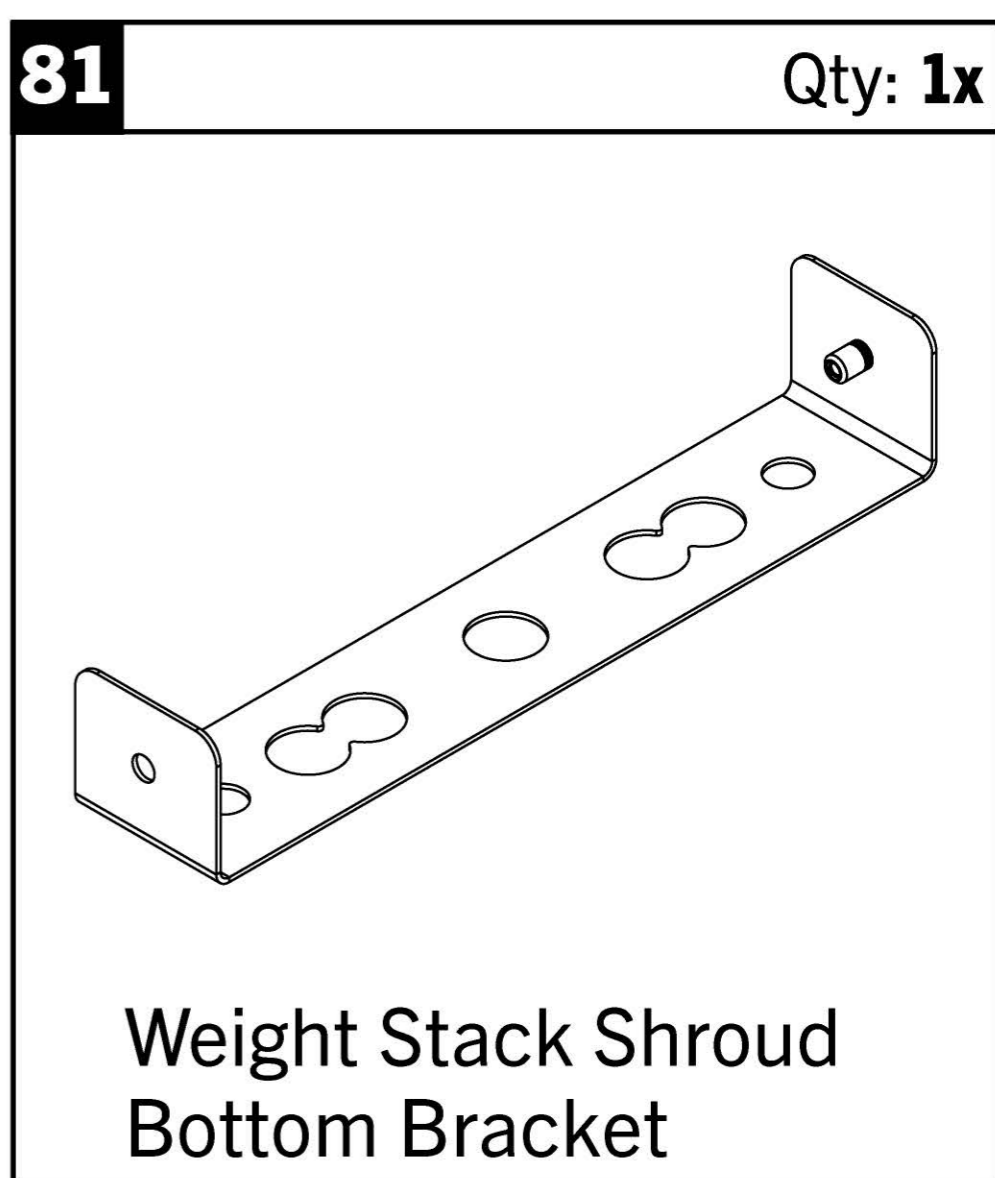
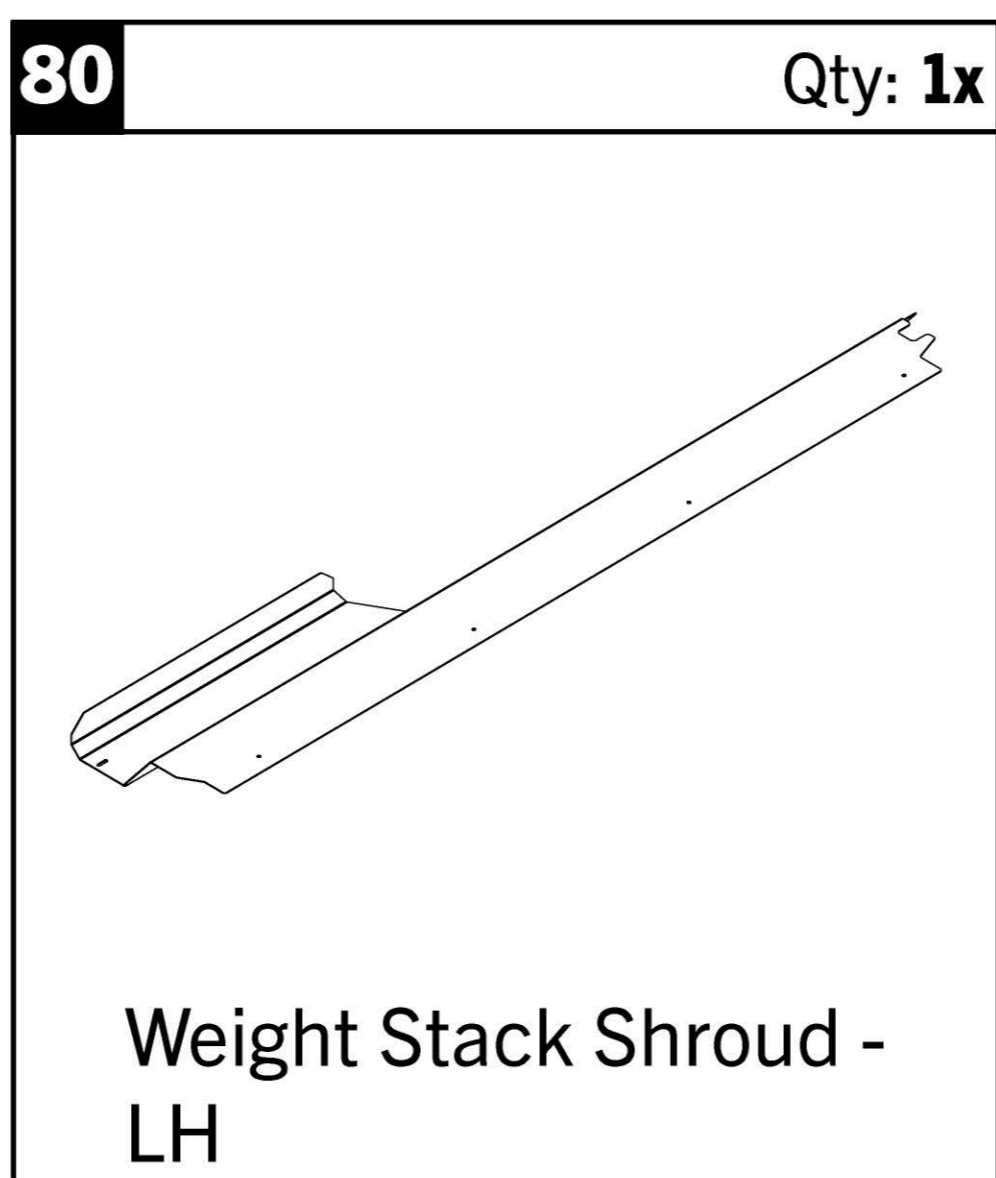
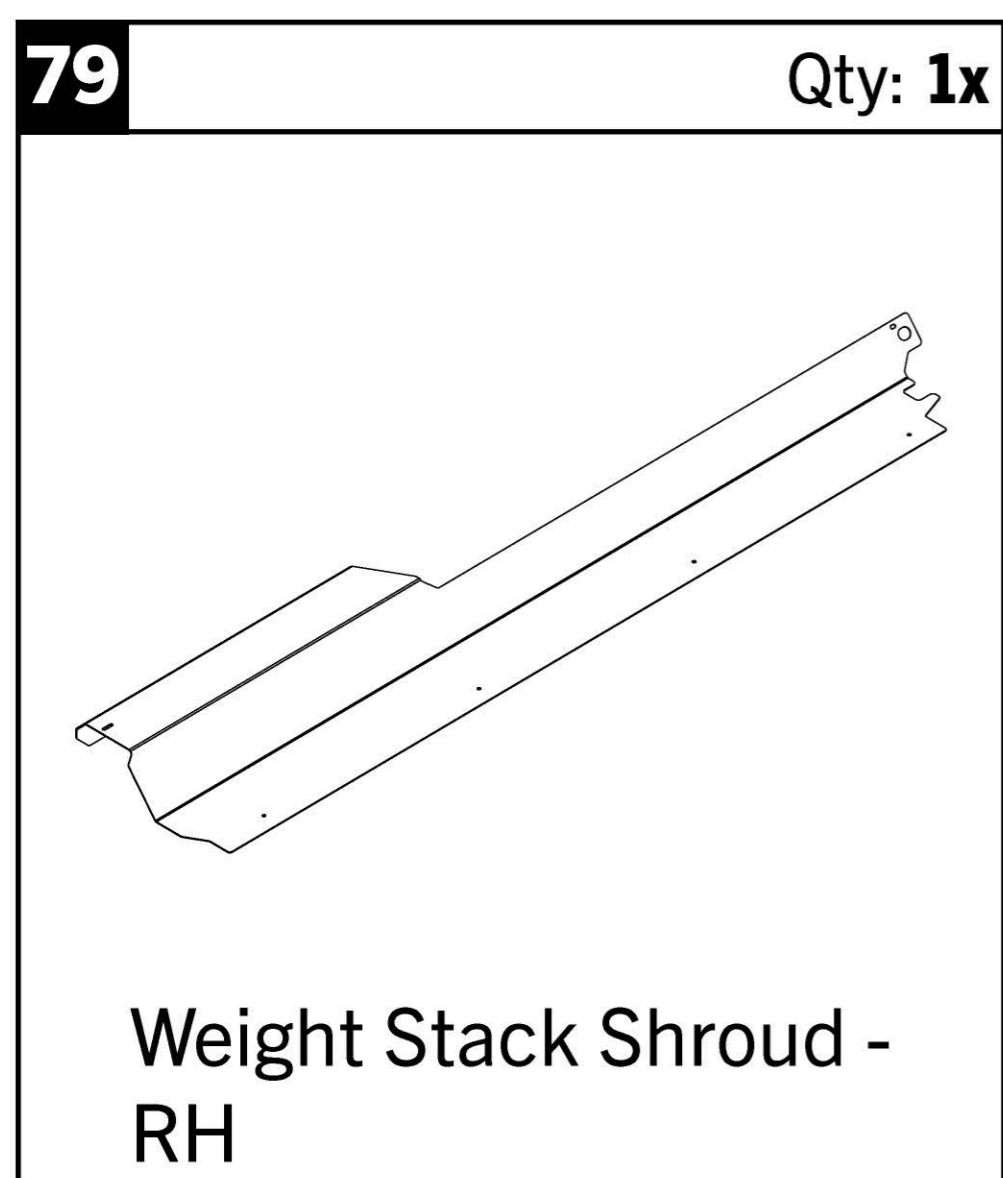

# INCLUDED PARTS: SHROUD KIT

Note: Images not shown at scale.

**91** Qty: **6x**

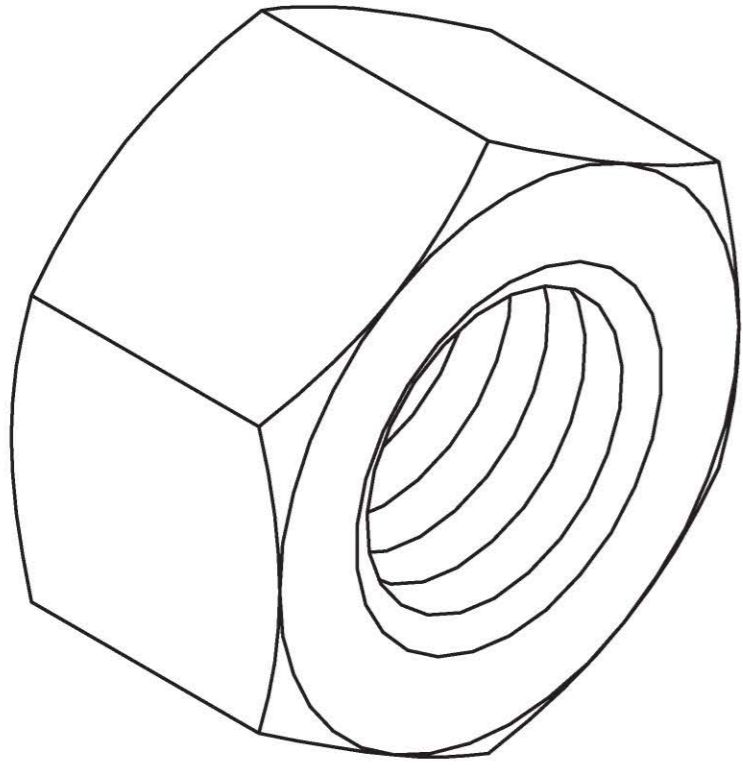

1" Hex Nut

**92** Qty: **6x**

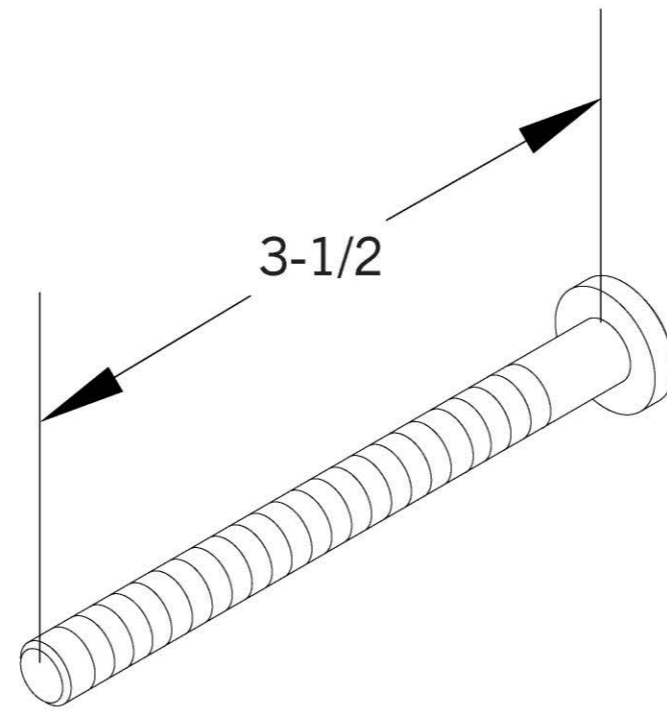

1/4" x 3-1/2" Button Head Screw

**93** Qty: **6x**

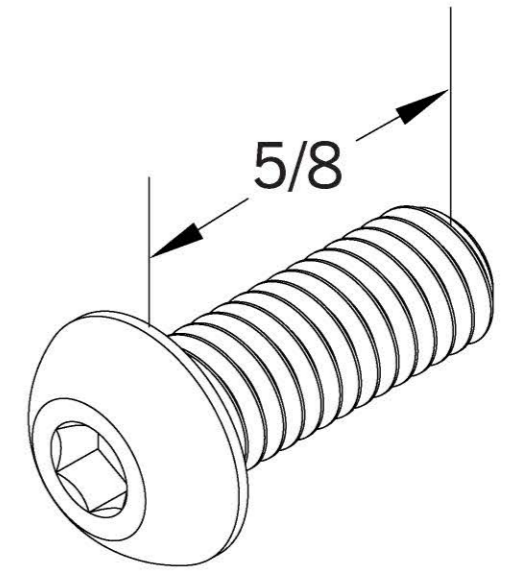

1/4" x 5/8" Button Head Screw

**94** Qty: **6x**

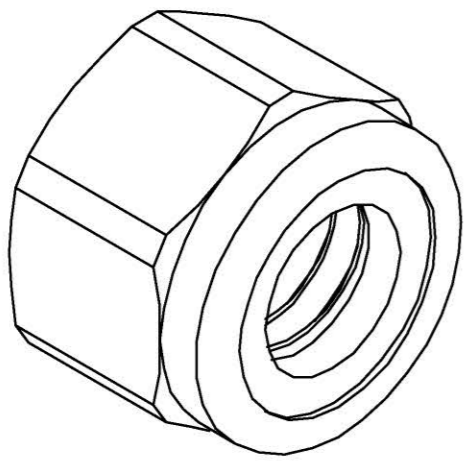

1/4" Nylock Nut

**95** Qty: **4x**

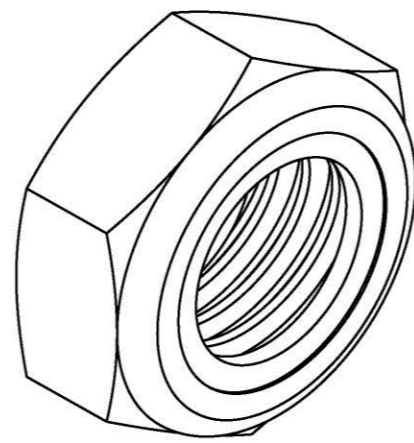

1/4" Thin Nylock Nut

# STEP 1

## Note:

- DO NOT use tools to tighten throughout assembly unless otherwise specified.
- If modifying existing rack with Add-on Kit, skip Steps 1-4 and proceed to **STEP 5**.
- While pulling the handle triggers, slide Swivel Trolley RH [19] and Swivel Trolley LH [20] onto two Monster Uprights [1].

- Note the orientation of Swivel Trolleys in relation to the feet at bottom of uprights.
- Slide about halfway down Upright and release triggers to lock pop pins in place when the viewing window is showing number 23.

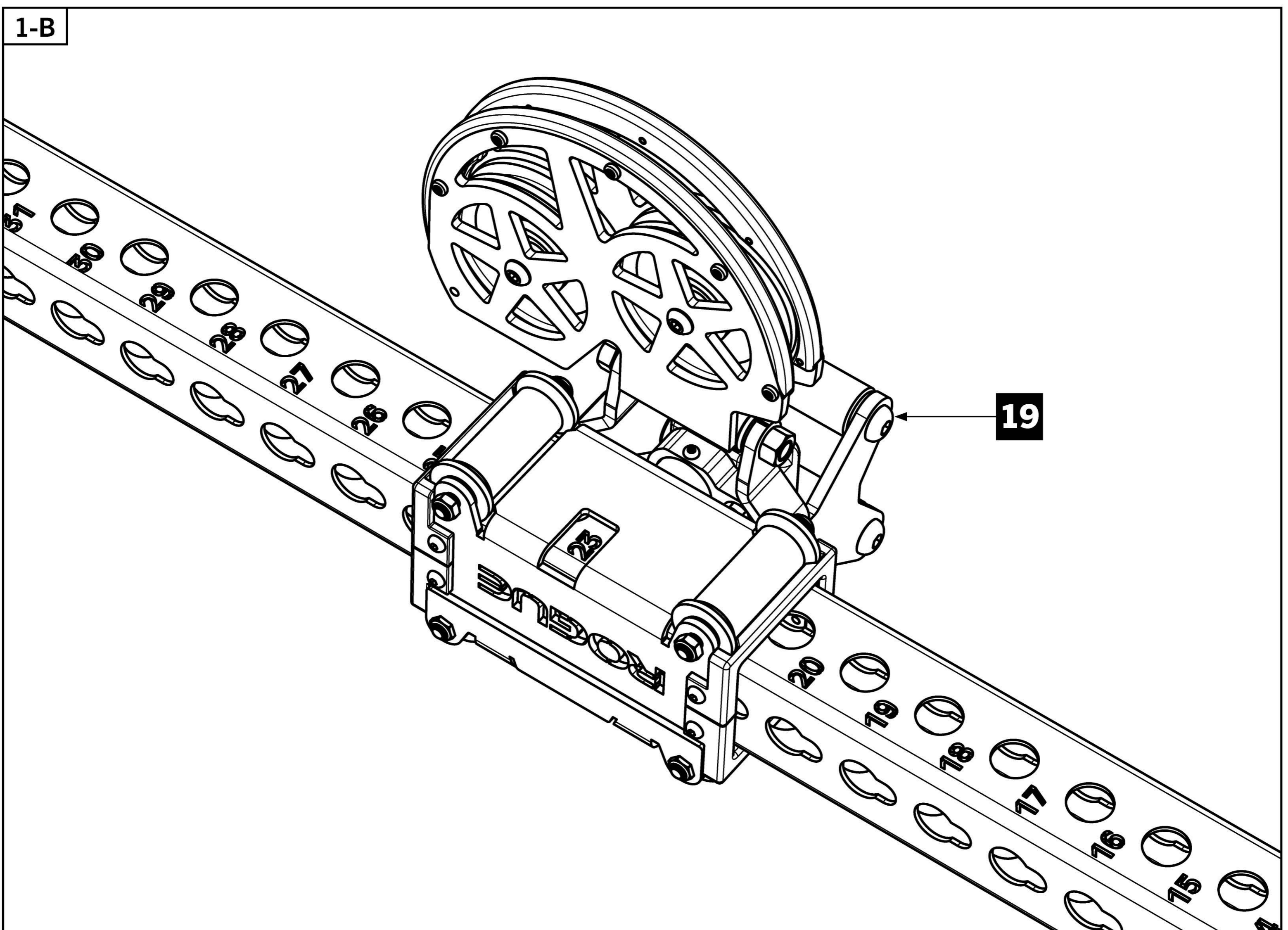
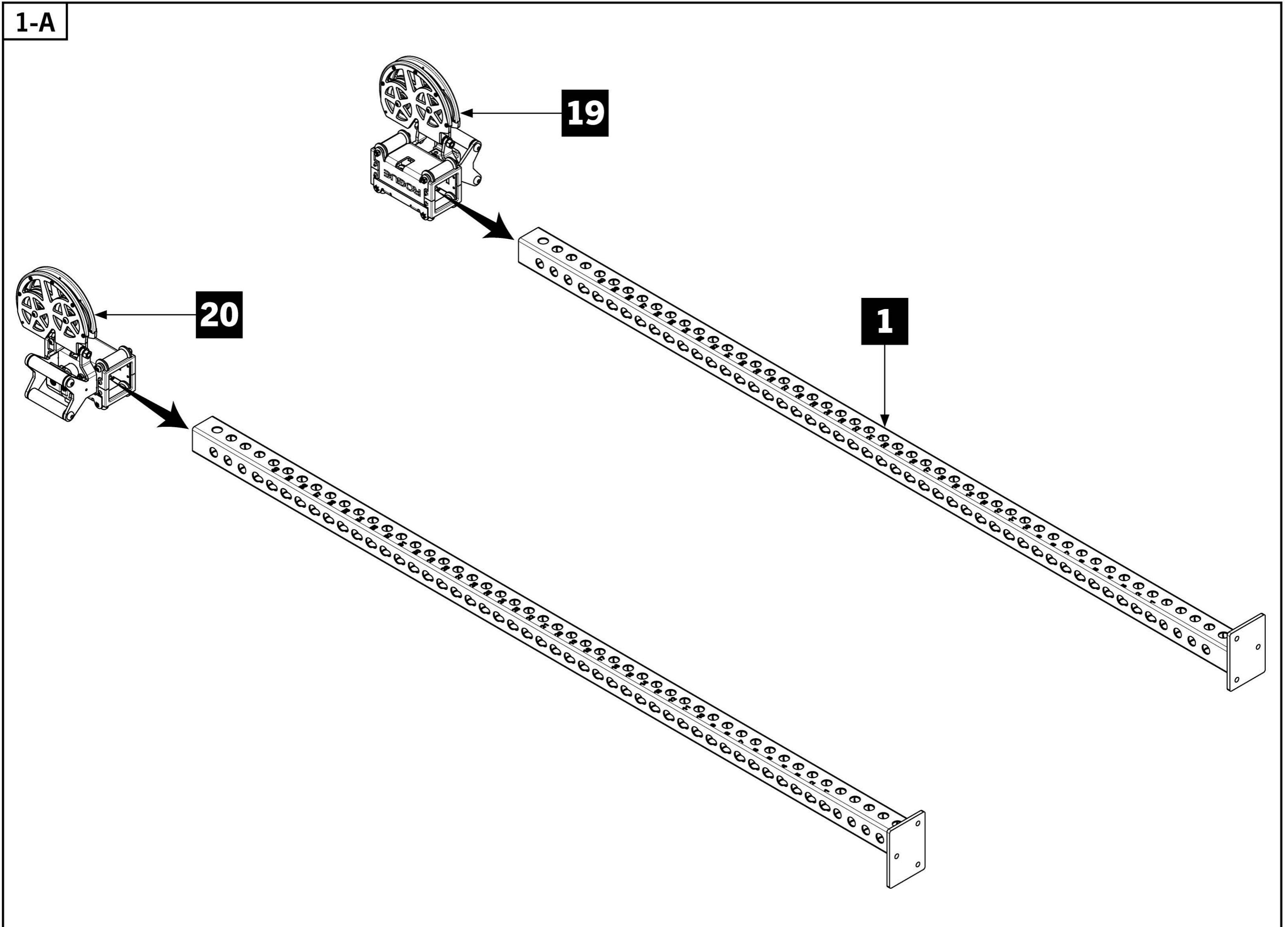

## STEP 2

- Refer to overview image to plan assembly and ensure ample floor space is allotted.
- Lay down all parts on a non-abrasive surface in the orientation shown below.
- Position the footplates of uprights approximately 55" apart.
- Note orientation of Swivel Trolleys and Upright feet in relation to the ground.
- Connect Uprights to Crossmembers using 1"x4-3/4" Hex Bolts [13], 1" x 5" Hex Bolts [12], 1" Flat Washers [14], 1" Lock Washers [15], and 1" Hex Nuts [16].
- Ensure to use 1" x 5" Hex Bolts [12] for central uprights.
- **HAND-TIGHTEN ONLY.** Do not use tools throughout assembly unless specified.

### OVERVIEW

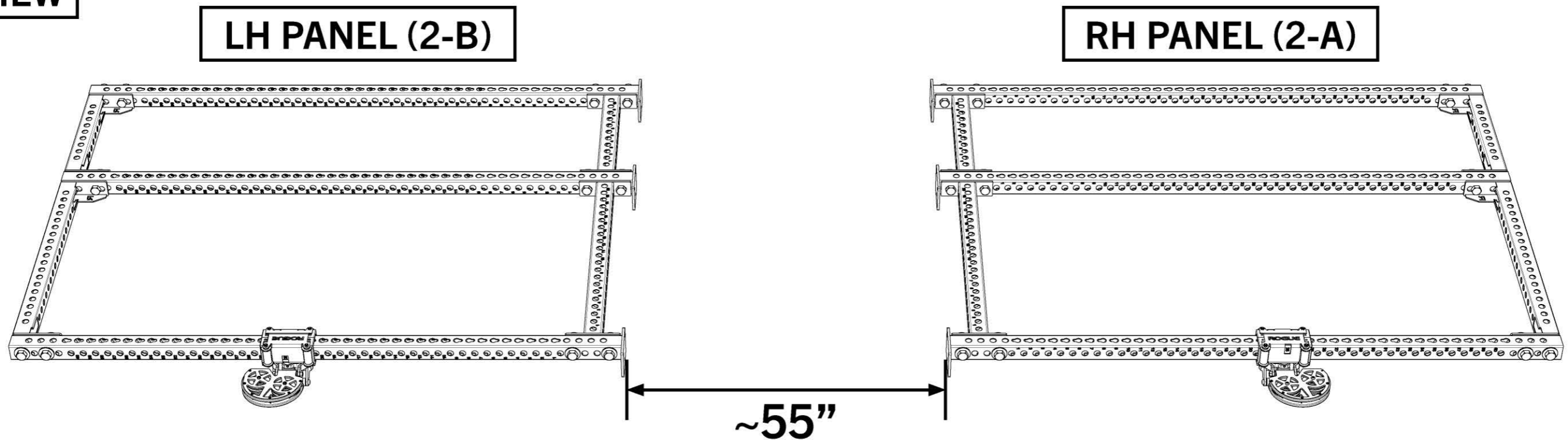

### 2-A

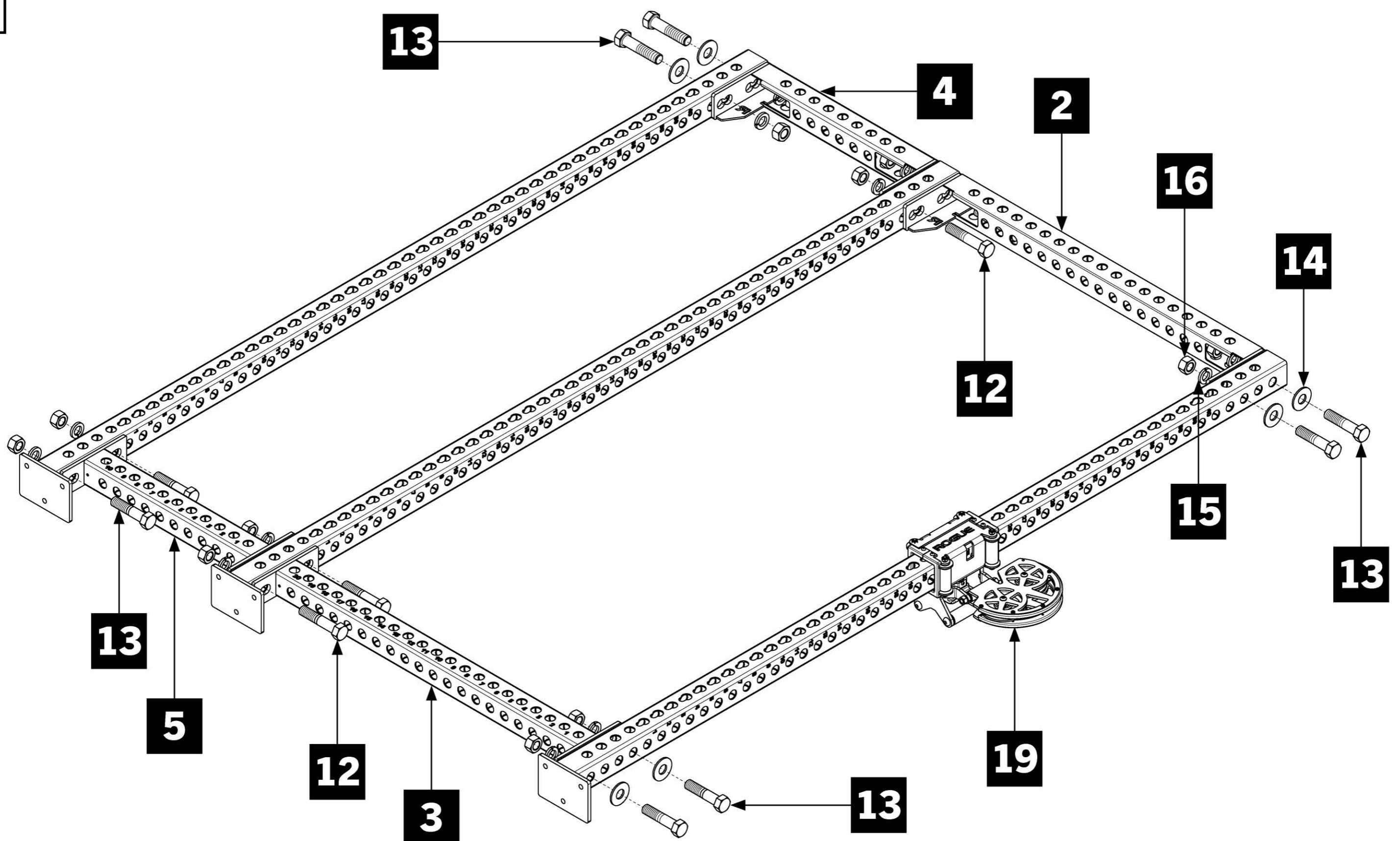

### 2-B

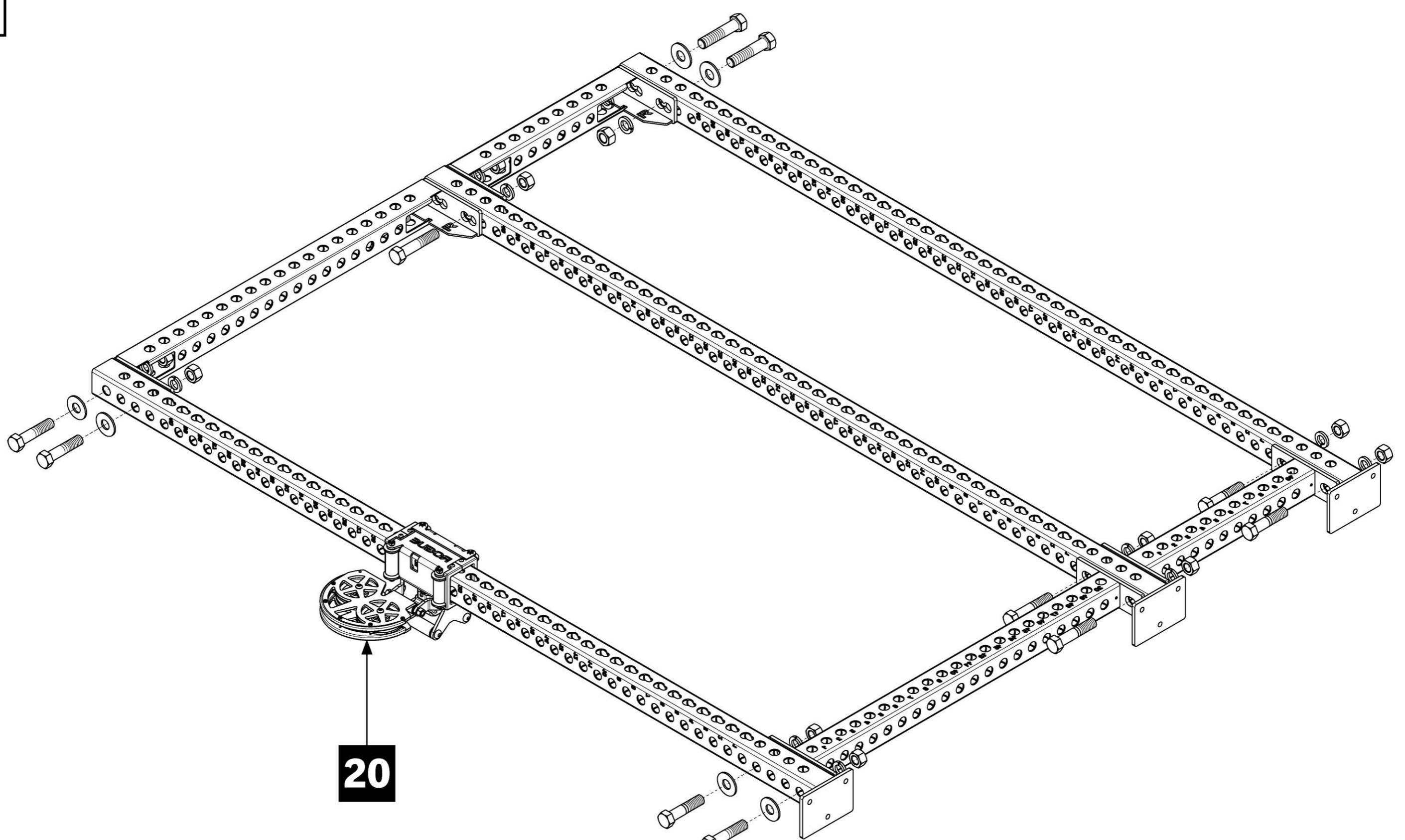

# STEP 3

## IMPORTANT:

- For safety, we recommend the remainder of these instructions be completed with **2 or 3 people**.
- Have two people stand one assembled panel up first.
- One person stabilizes the first panel while the other stands up the second panel.

- One or two people should stabilize both panels, ensuring panels don't fall while another person assembles the spanning Crossmembers in **STEP 4**.

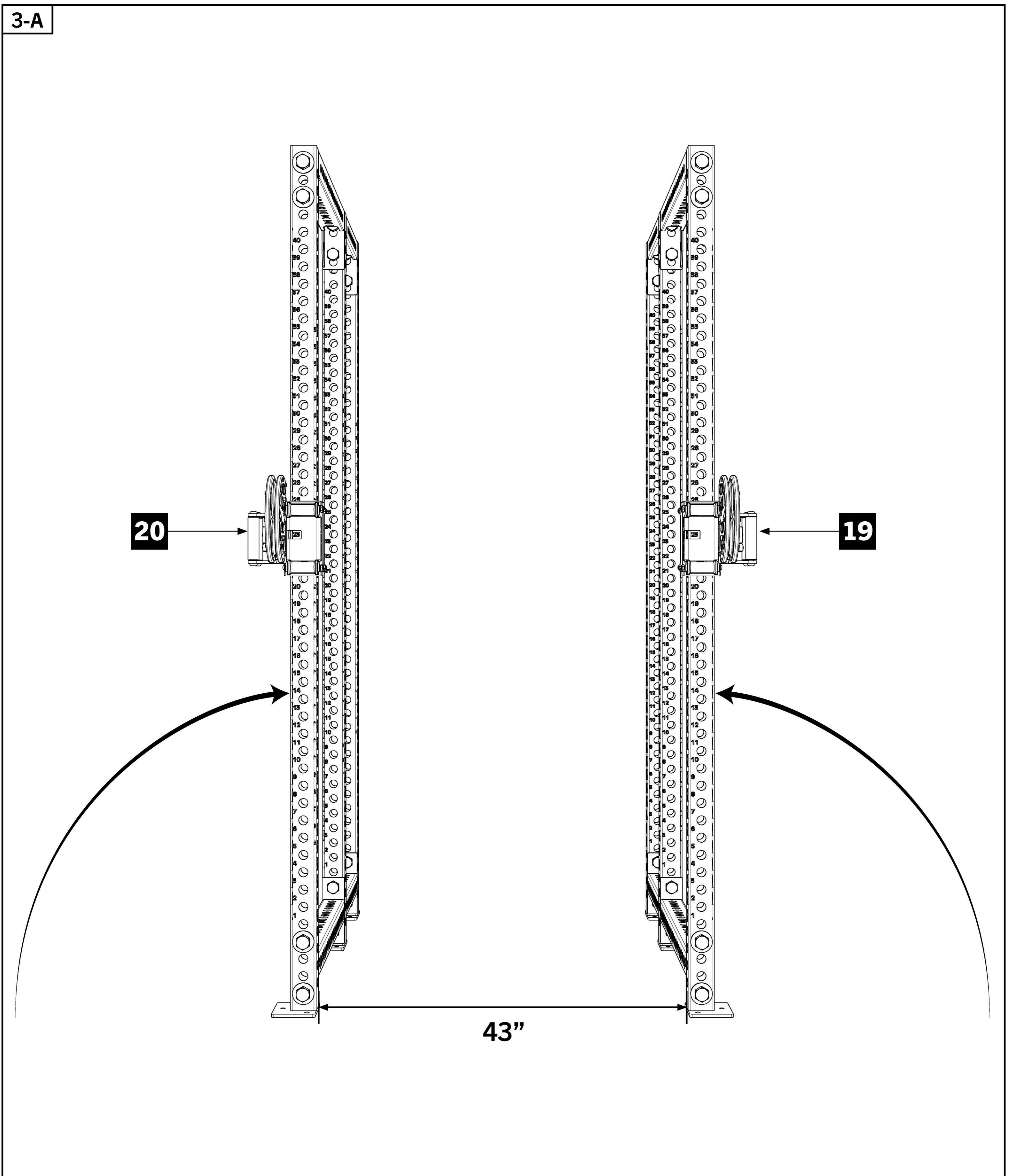
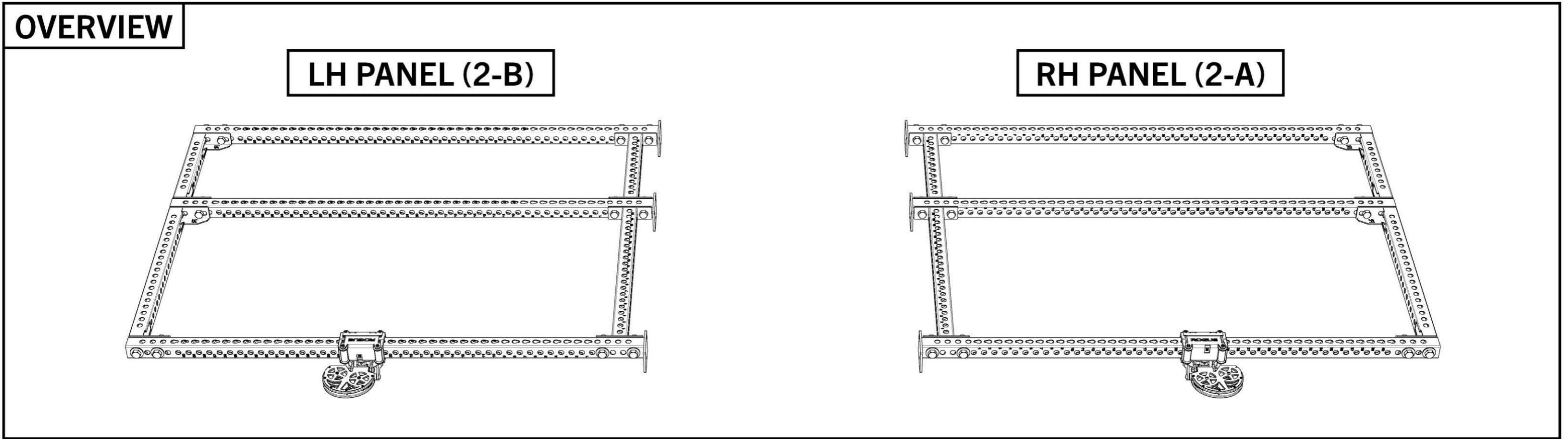



# STEP 4

## Tools Required:

- 3/8" Allen Key
- Attach Nameplate Crossmember [6] to middle Uprights using 1" x 4-3/4" Hex Bolt [13], 1" Flat Washers [14], 1" Lock Washers [15], and 1" Hex Nuts [16].

- Attach Pull-up Bar [7] to front Uprights using 1" Shoulder Bolts [63,62], 1" x 4-1/2" Hex Bolts, 1" Flat Washers, 1" Lock Washers, and 1" Hex Nuts.
- **!** Fully tighten 1" Shoulder Bolts using 3/8" Allen Key. **DO NOT TIGHTEN HEX BOLTS.**

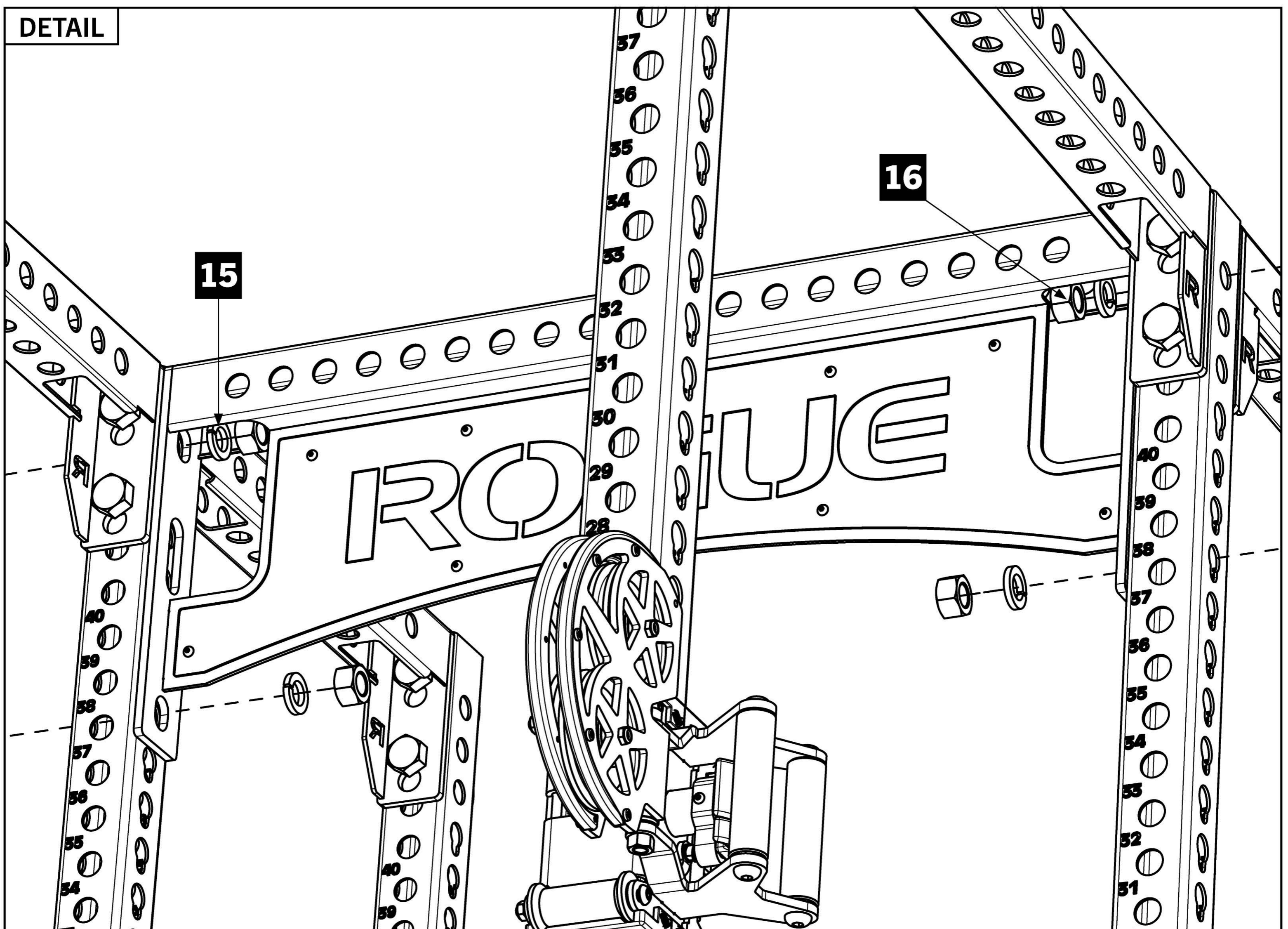
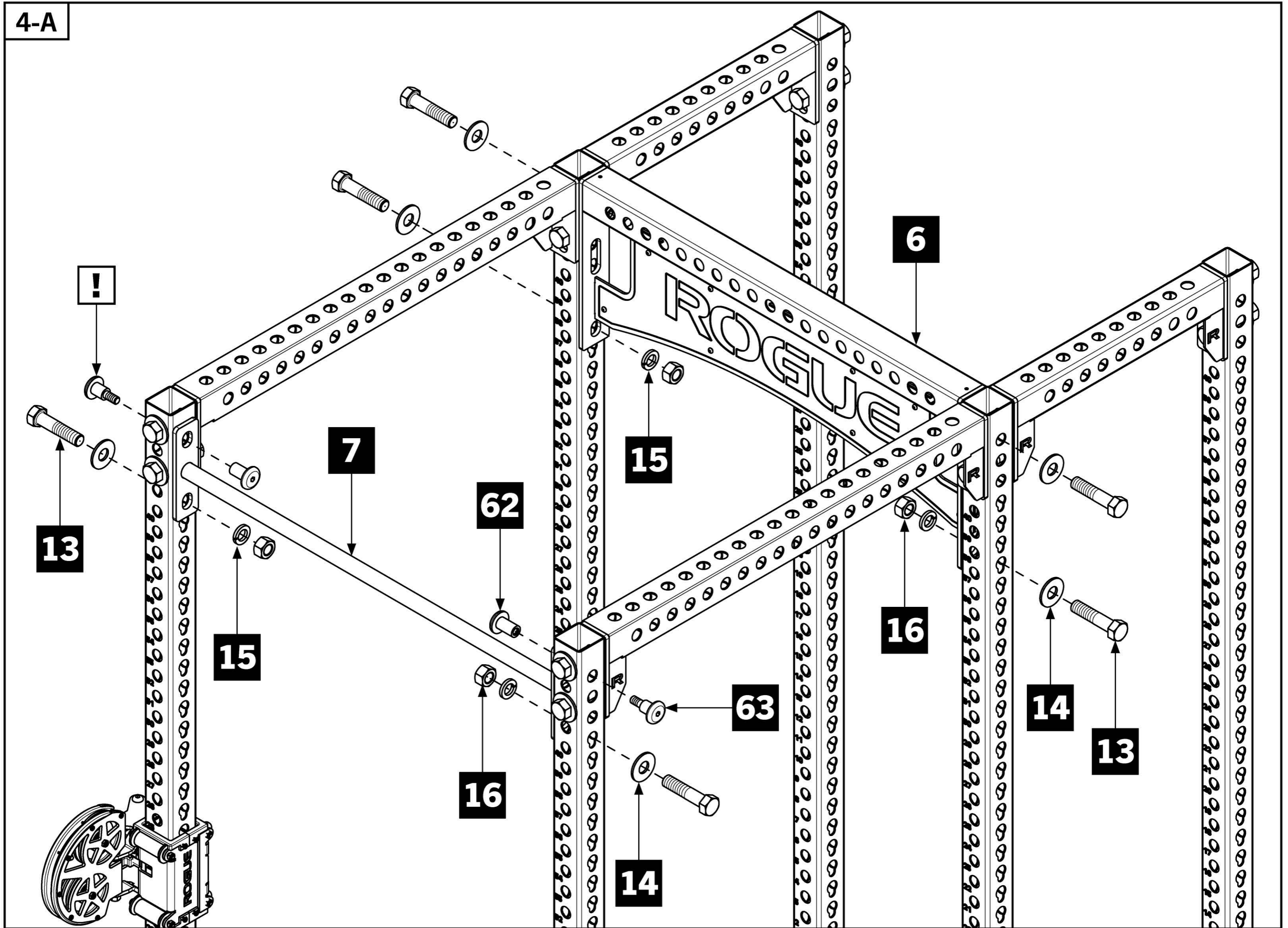

## STEP 5 (BEGIN ADD-ON KIT ASSEMBLY)

- If modifying existing RM rack with add-on kit, begin following assembly instructions.
- Leaving 1" x 4-3/4" Hex Bolts in place, remove all four lower Lock Washers and Hex Nuts from rear Uprights as shown in 5-A.
- Attach Low Row Crossmember [18] and re-assemble the hardware removed above.

### Note:

- "X" cutout on Low Row Crossmember should be facing down towards the ground.

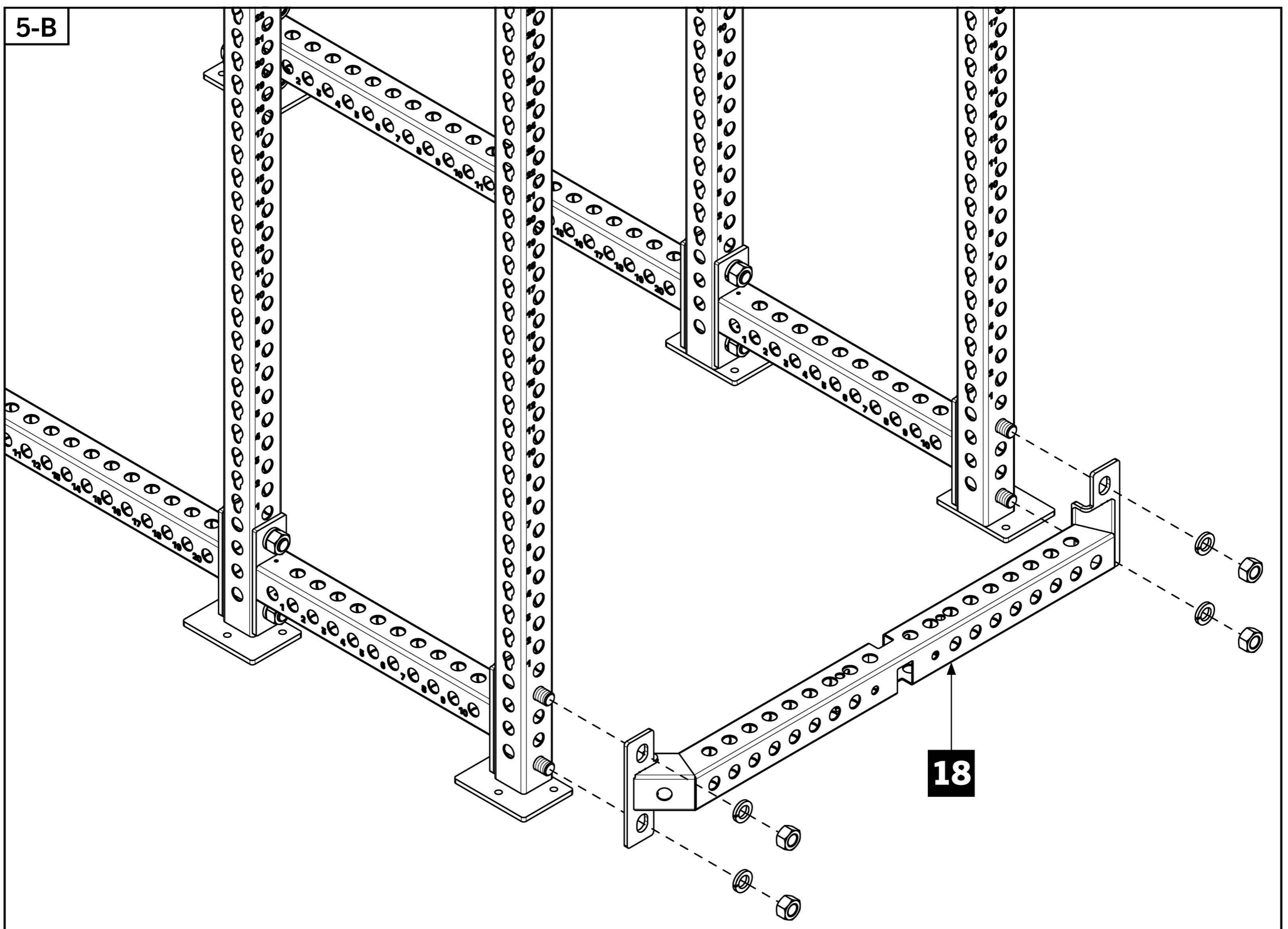
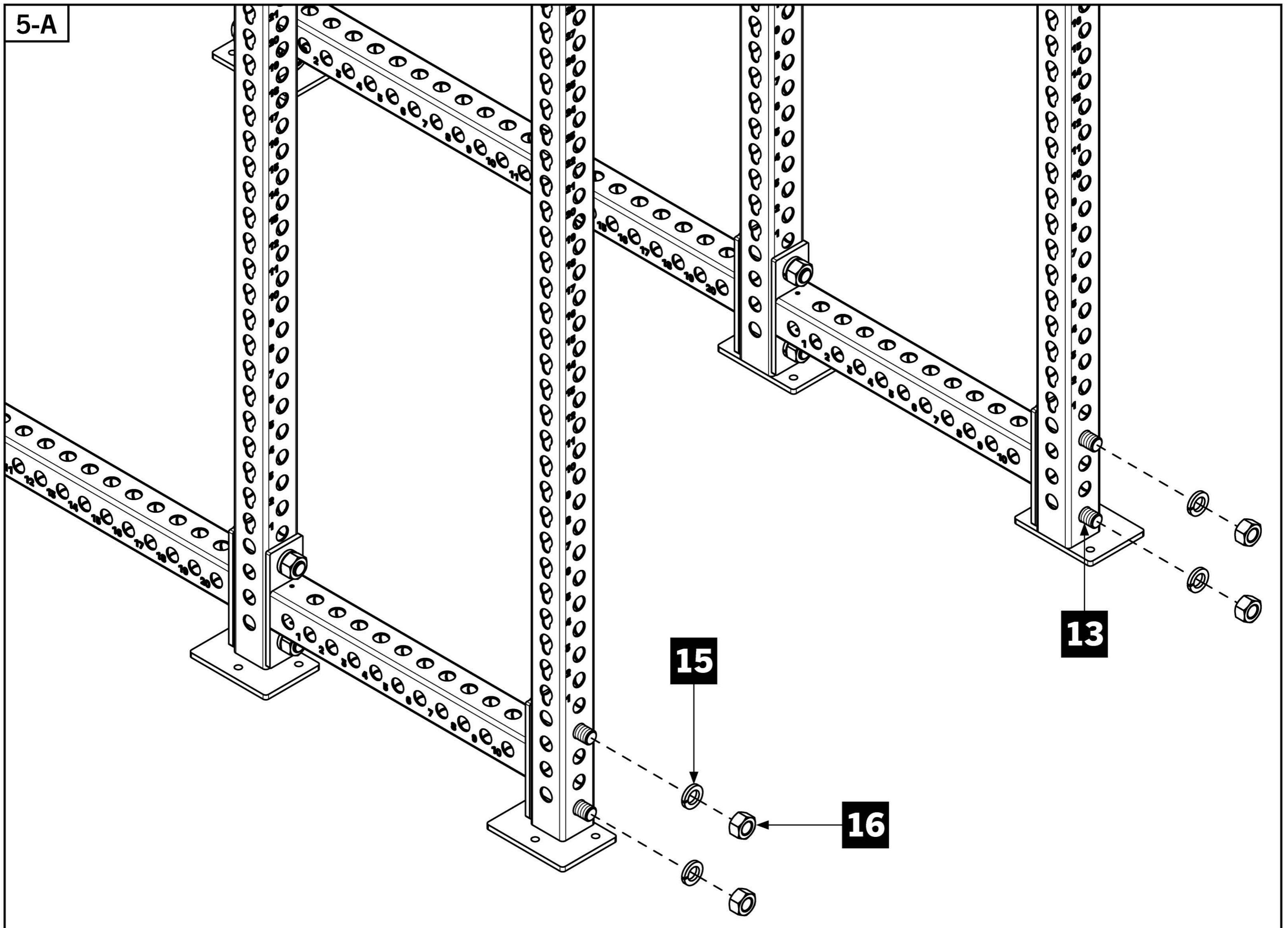

## STEP 6 (ADD-ON KIT ONLY)

### Tools Required:

- 1-1/2" Wrench
- Loosen but do not remove all 1" hardware on entire rack.
- Remove Pull-up Bar and hardware from front of rack and set parts aside.
- Remove additional 1" crossmember hardware shown in **6-B** so that the tops of the front uprights are completely free to move.

### Note:

- The tops of the front uprights will need ample slack to complete **STEP 7**. Continue to loosen hardware on bottom of Front Uprights as needed.

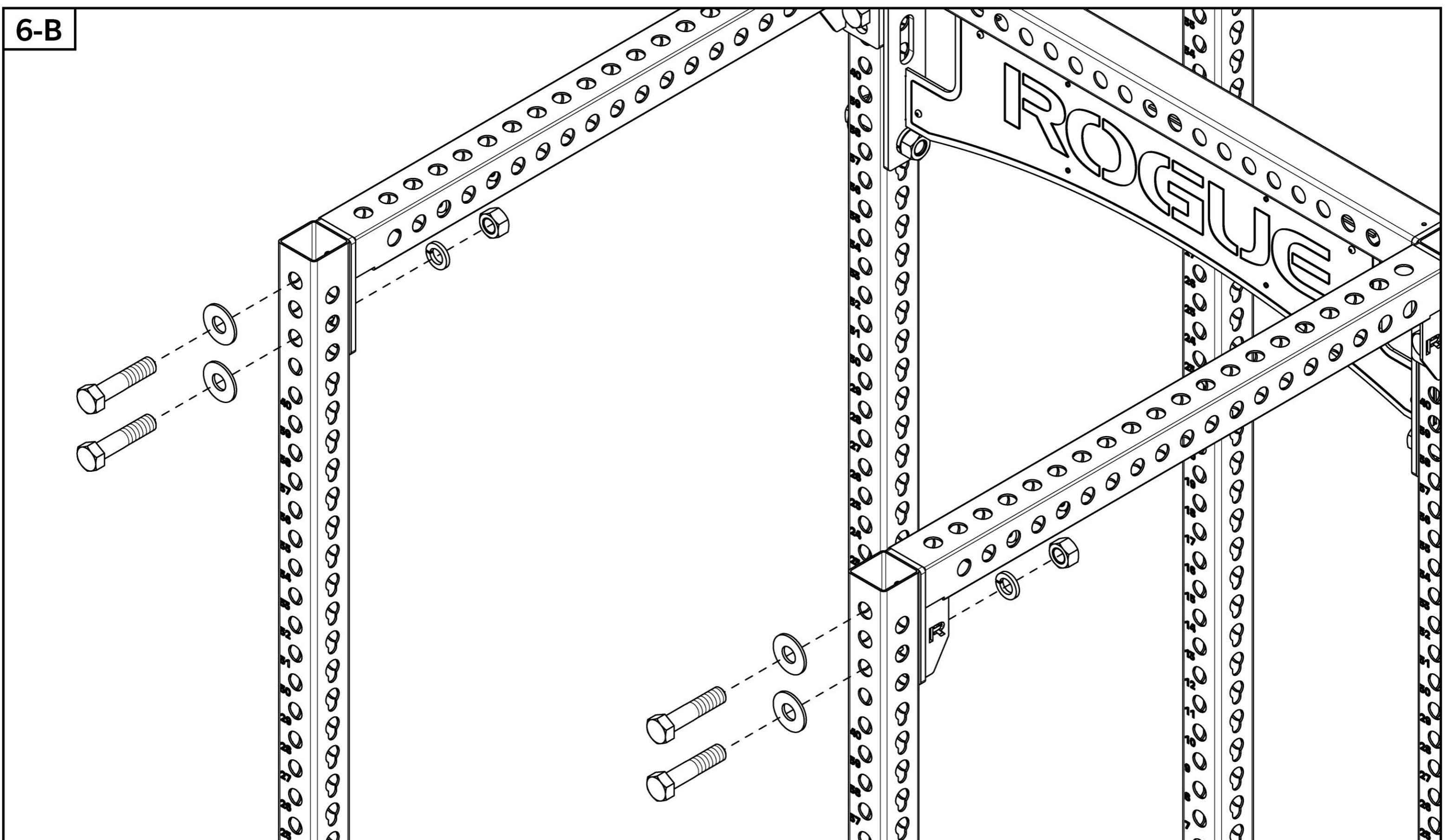
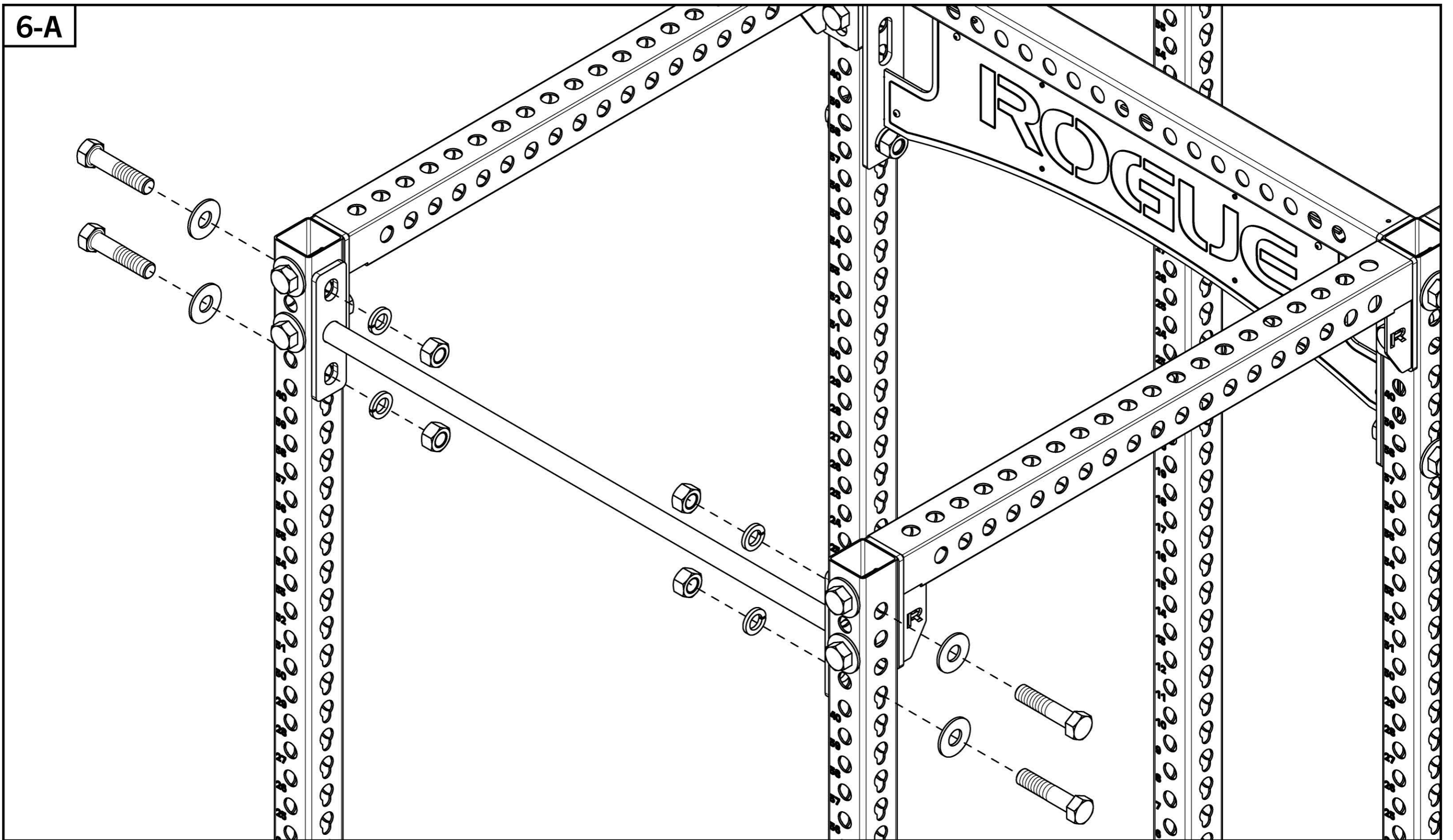
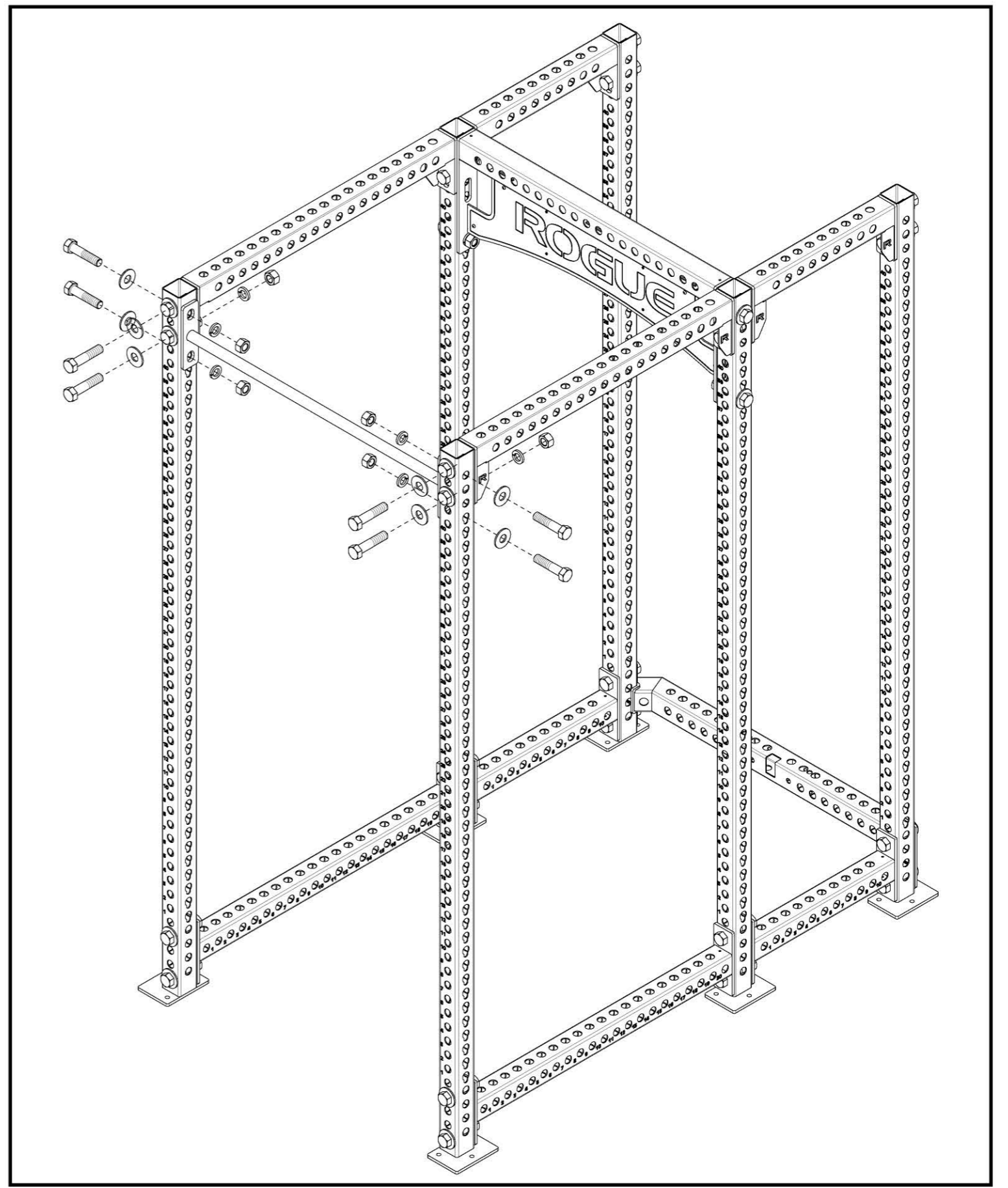

## STEP 7 (ADD-ON KIT ONLY)

- While tilting Upright forward, pull the handle triggers and slide LH Swivel Trolley [20] down the front left Upright.
- Repeat this process to assemble RH Swivel Trolley [19] on front right Upright.
- Slide down the Uprights and release triggers when the viewing window is showing the number 23 (refer to **STEP 1-B**).

- Assemble hardware removed in **STEP 6**, replacing the indicated top outer bolts with 1" Shoulder Bolts. **!** Fully tighten **ONLY** the 1" Shoulder Bolts using two 3/8" Allen Keys.

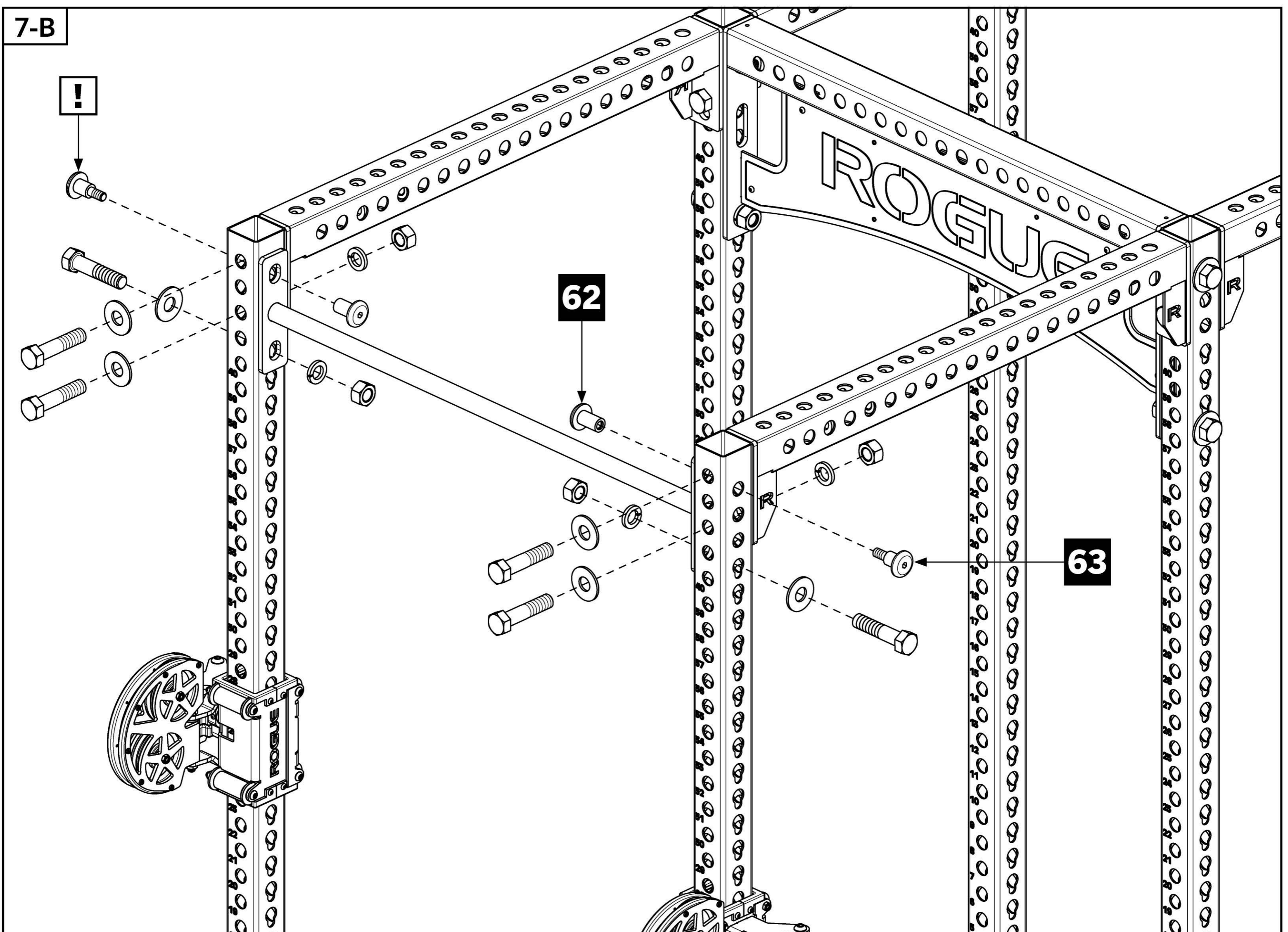
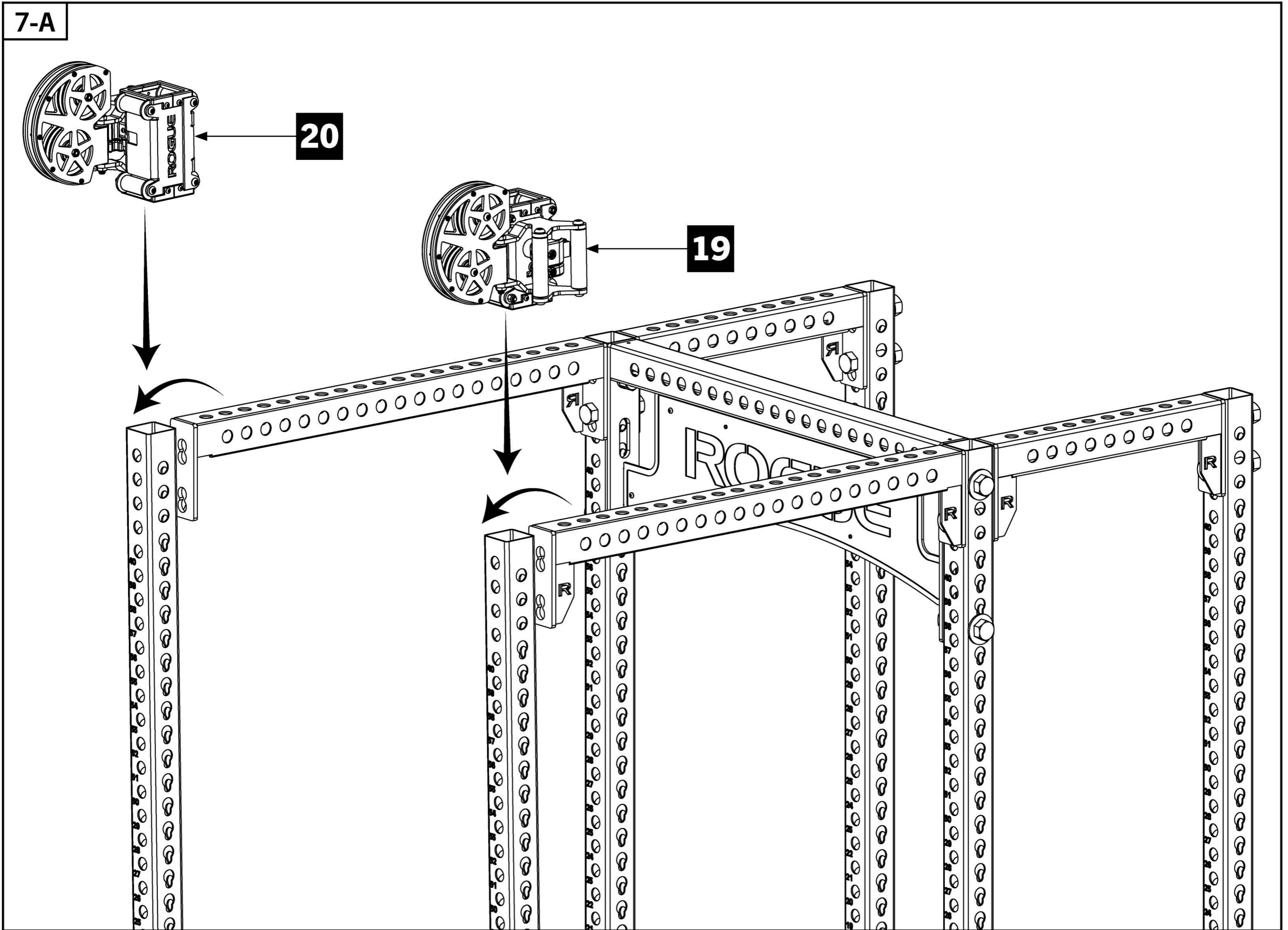

## STEP 8

### Tools Required:

- 7/32" Allen Key, 9/16" Wrench
- Swivel Trolleys [19] and [20] need to be calibrated for your specific rack.
- Keeping the Swivel Trolleys locked in place, tighten the Button Head Screws shown in **8-A** using 7/32" Allen Key until looseness or "wobble" is gone.

- Unlock pop pins and roll Trolleys up and down Upright several inches to feel tightness. If wobble persists, tighten the Screws in **8-A** again. If any friction is felt, Trolleys are too tight and Screws should be loosened a quarter turn.

- Once calibrated, tighten both rollers on rear of Trolleys using Allen Key and Wrench.

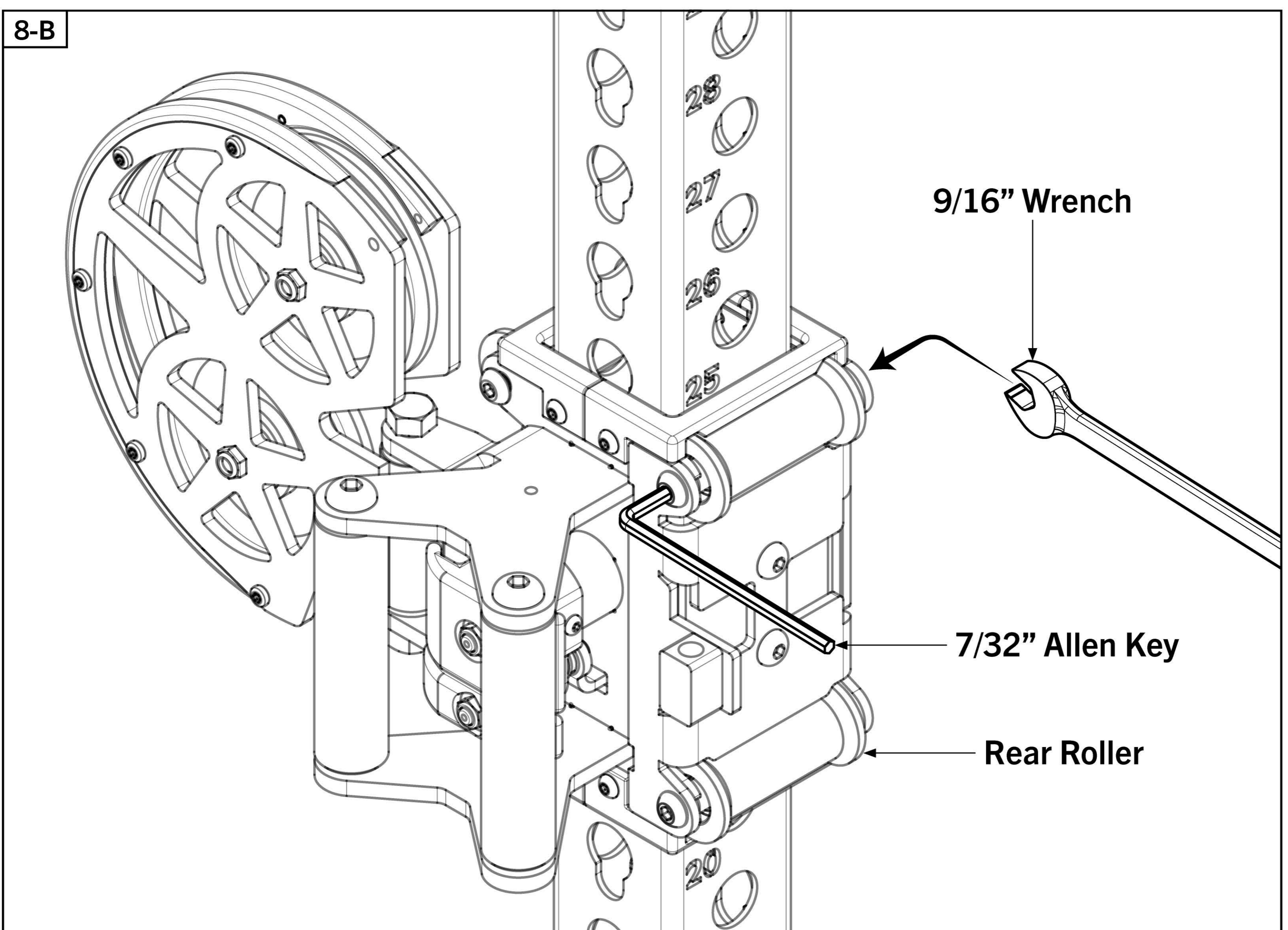
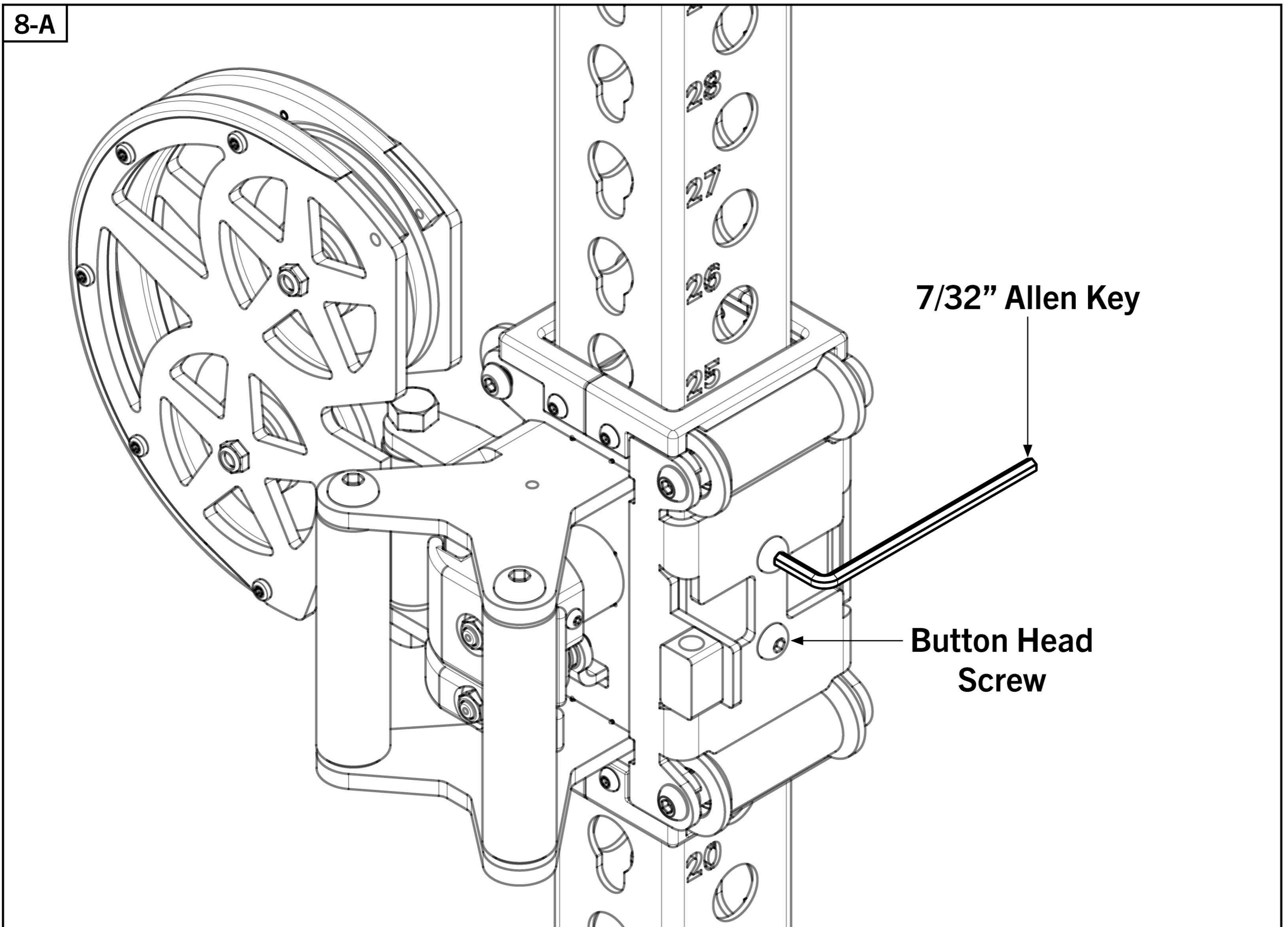

# STEP 9

- For ease of assembly, pull the pop-pin and remove Foot Catch from Low Row Foot Plate Assembly as shown in detail view (right).
- Attach Foot Plate Assembly [28] and Low Rear Pulley Assembly [29] to Low Row Crossmember [18] using indicated 5/8" and 1/2" hardware below.

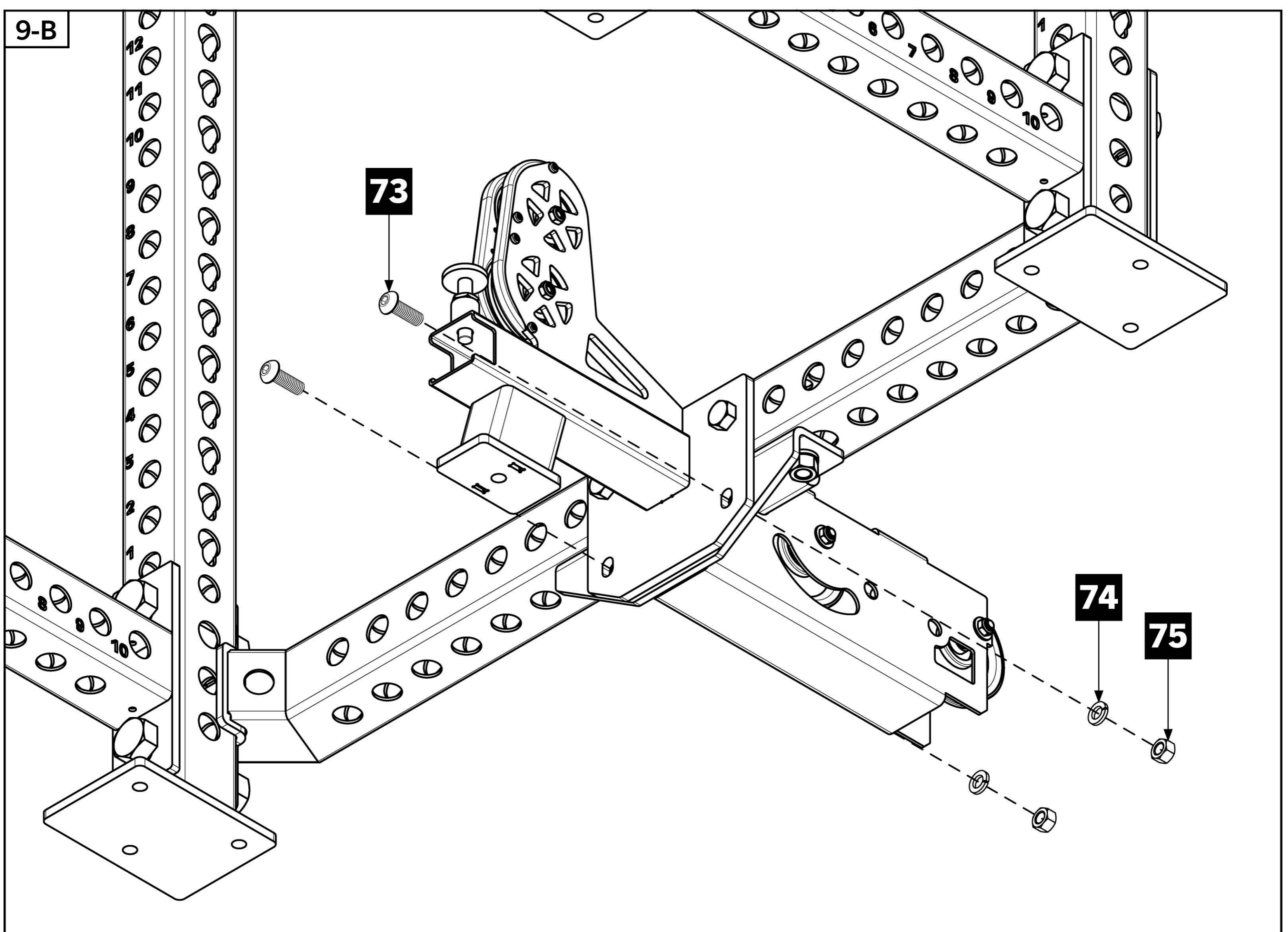
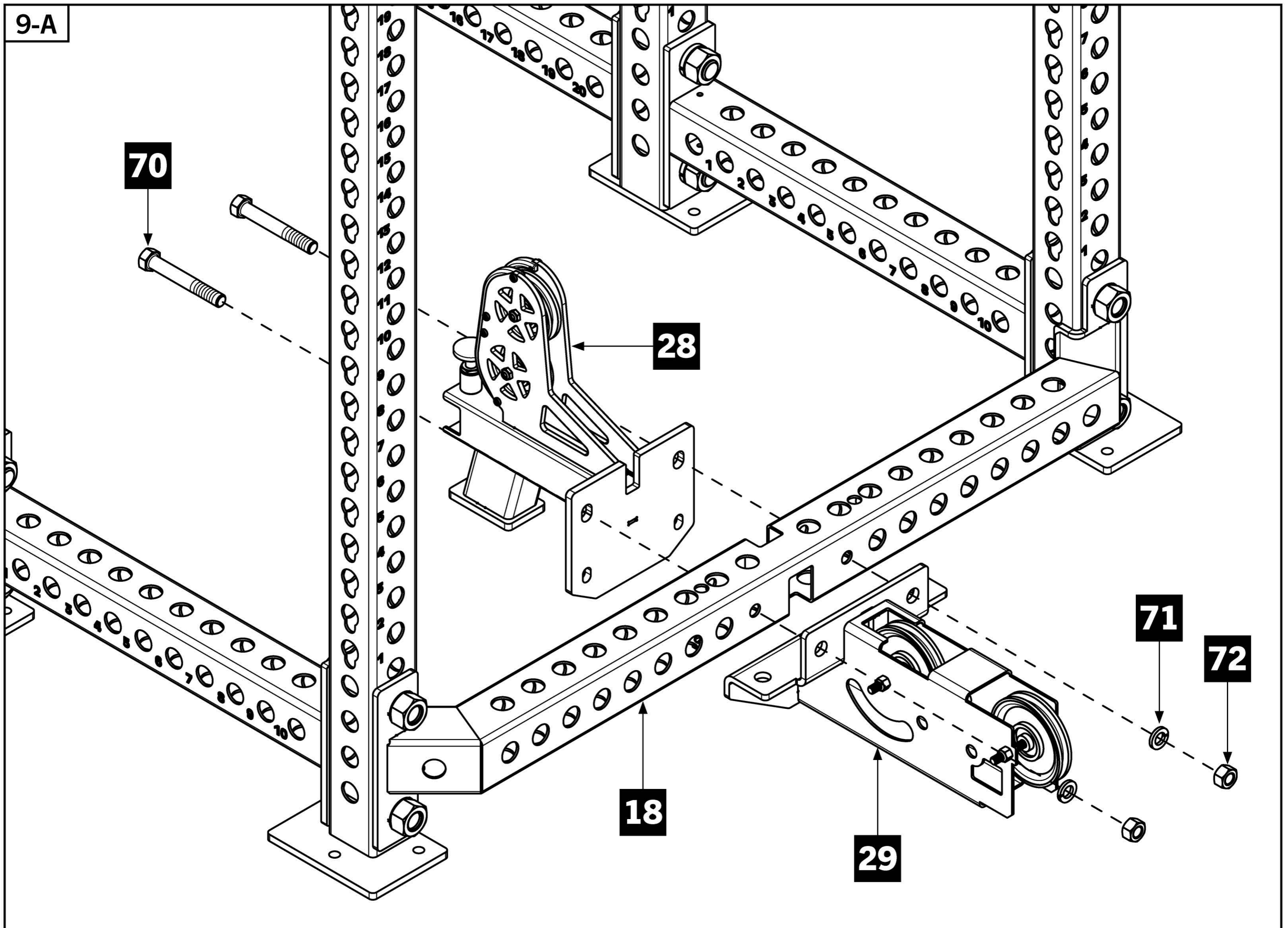
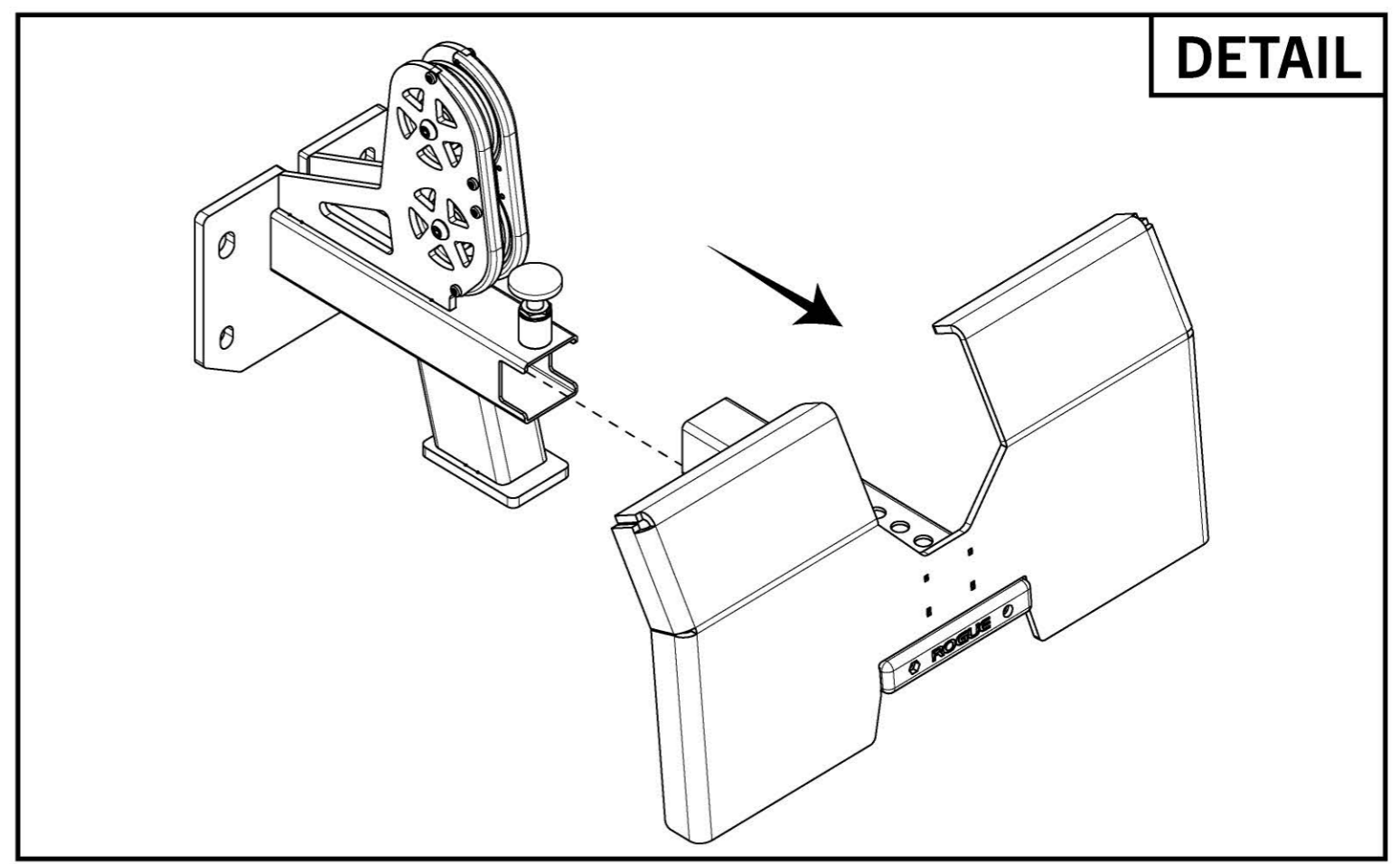

# STEP 10

- Align Rear 3X3 Upright [17] to back of Low Rear Pulley Assembly [29]. Footplate should slide under the cutout at the bottom of Pulley Assembly.
- Secure Upright to Pulley Assembly by attaching 5/8" x 4-1/2" Hex Bolts [70], Rear Connector Plates [30], 5/8" Lock Washers [71], and 5/8" Hex Nuts [72].

### Note:

- Ensure Rear Connector Plates are installed with the arrow indicator stickers facing outward as shown in 10-B.

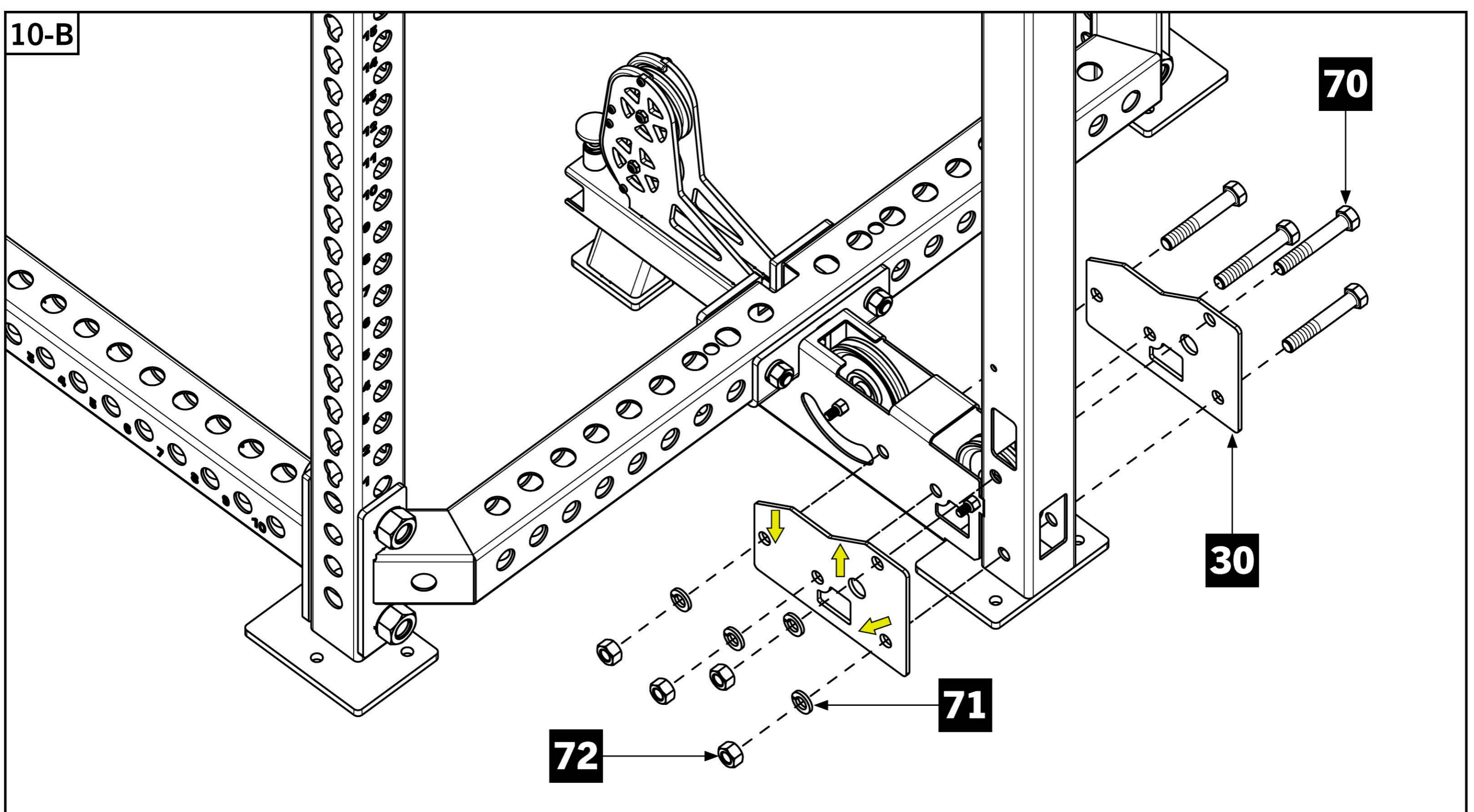
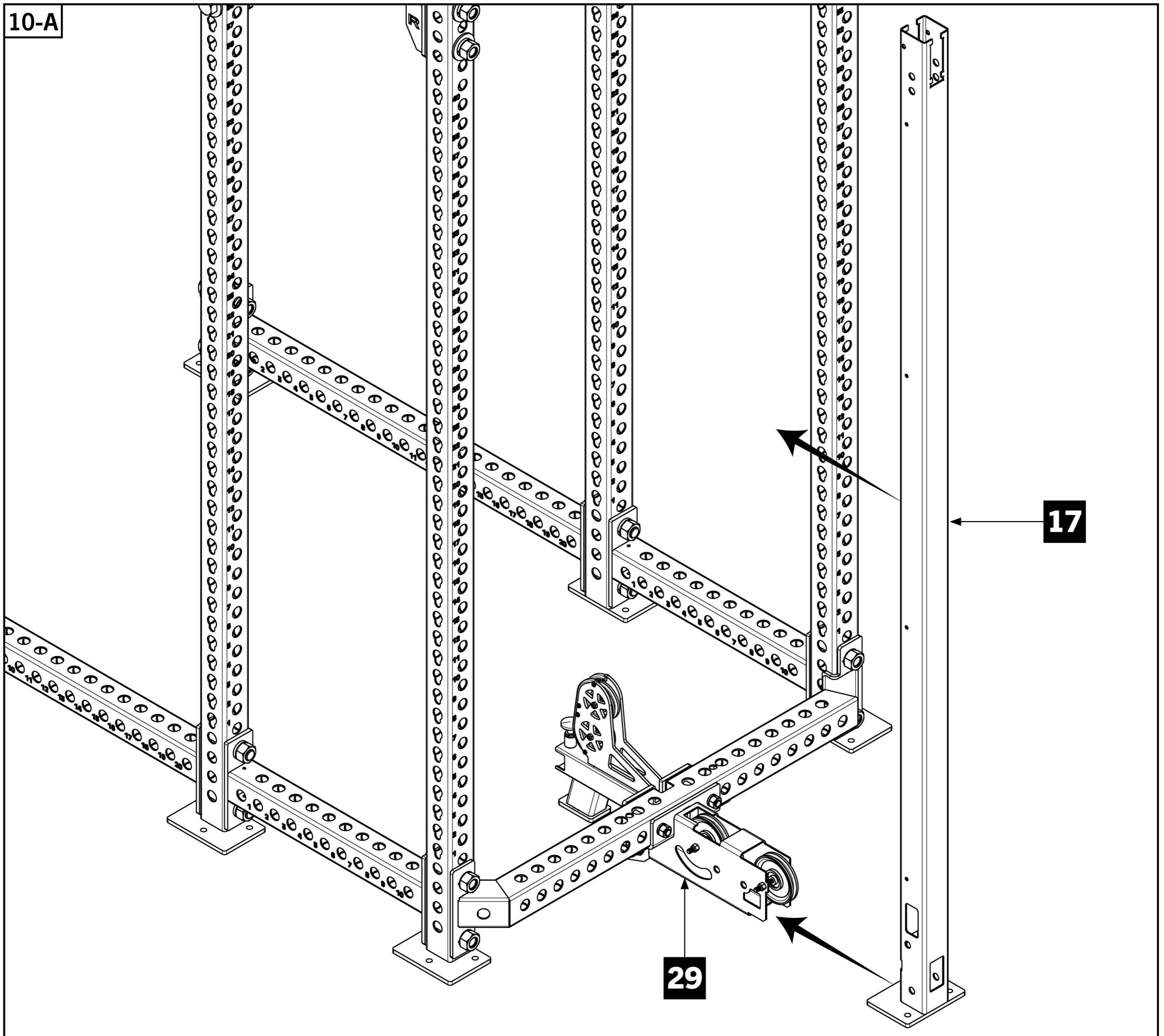

# STEP 11

## Tools Required:

- 15/16" Wrench
- Attach Weight Stack Shroud Bottom Bracket [81] and Weight Stack Spacer [35] to middle of Low Row Crossmember [18] by using 5/8" x 5" Hex Bolts [69], 5/8" Lock Washers [71], and 5/8" Hex Nuts [72].
- Fully tighten 5/8" vertical hardware in 11-A.

- Place Weight Stack Bumpers [37] over outer 1" holes on the Weight Stack Spacer and insert Guide Rods [31] until they rest on top of the Low Row Crossmember.

## Note:

- Shroud Bracket [81] only included if shroud kit was purchased. Simply bolt the Weight Stack Spacer using hardware shown if shrouds were not purchased.

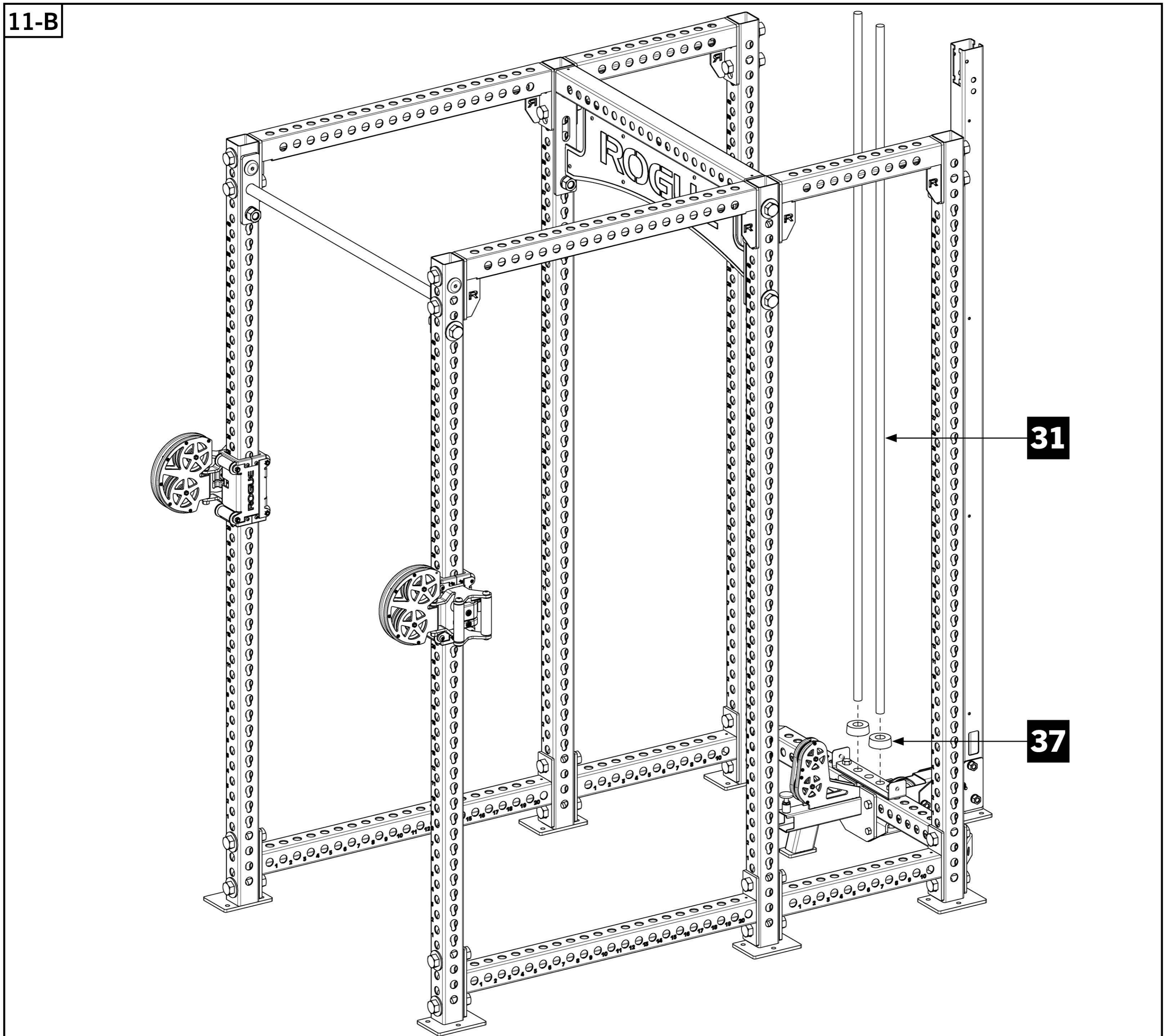
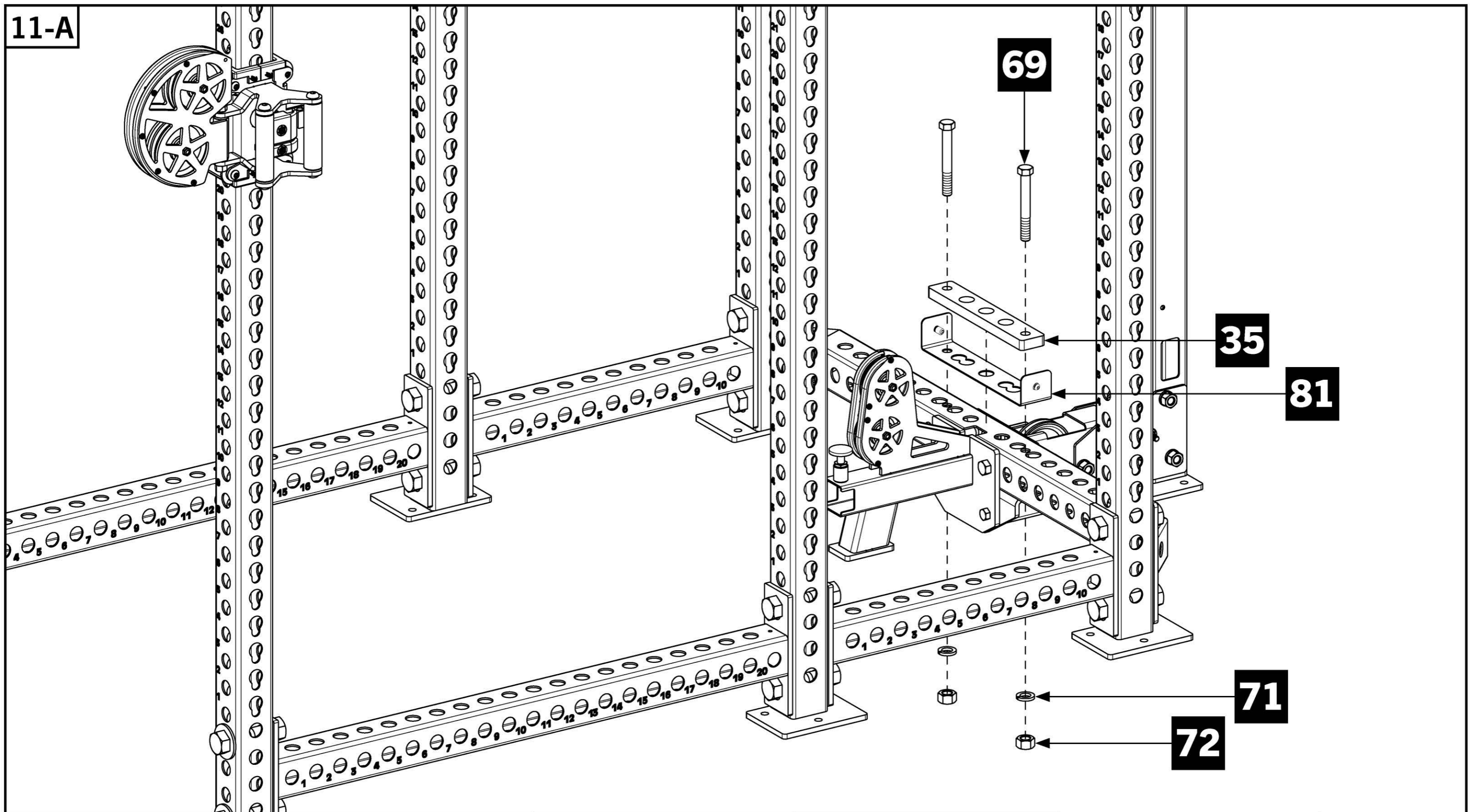



## STEP 12

- Angle the Guide Rods toward the front of the rack.
- One at a time, carefully stack all included 10LB Weight Stack Plates [33] down the Guide Rods [31], ensuring not to drop them.
- **Note:** this is best accomplished with two or three people.
- Once all weights are stacked, slide the Weight Stack Stem [32] down the Guide Rods until resting on top of weight stack.
- Ensure 20LB Weight Stack Sticker on the top Plate of the stack is facing towards the front of rack as shown in Detail view.

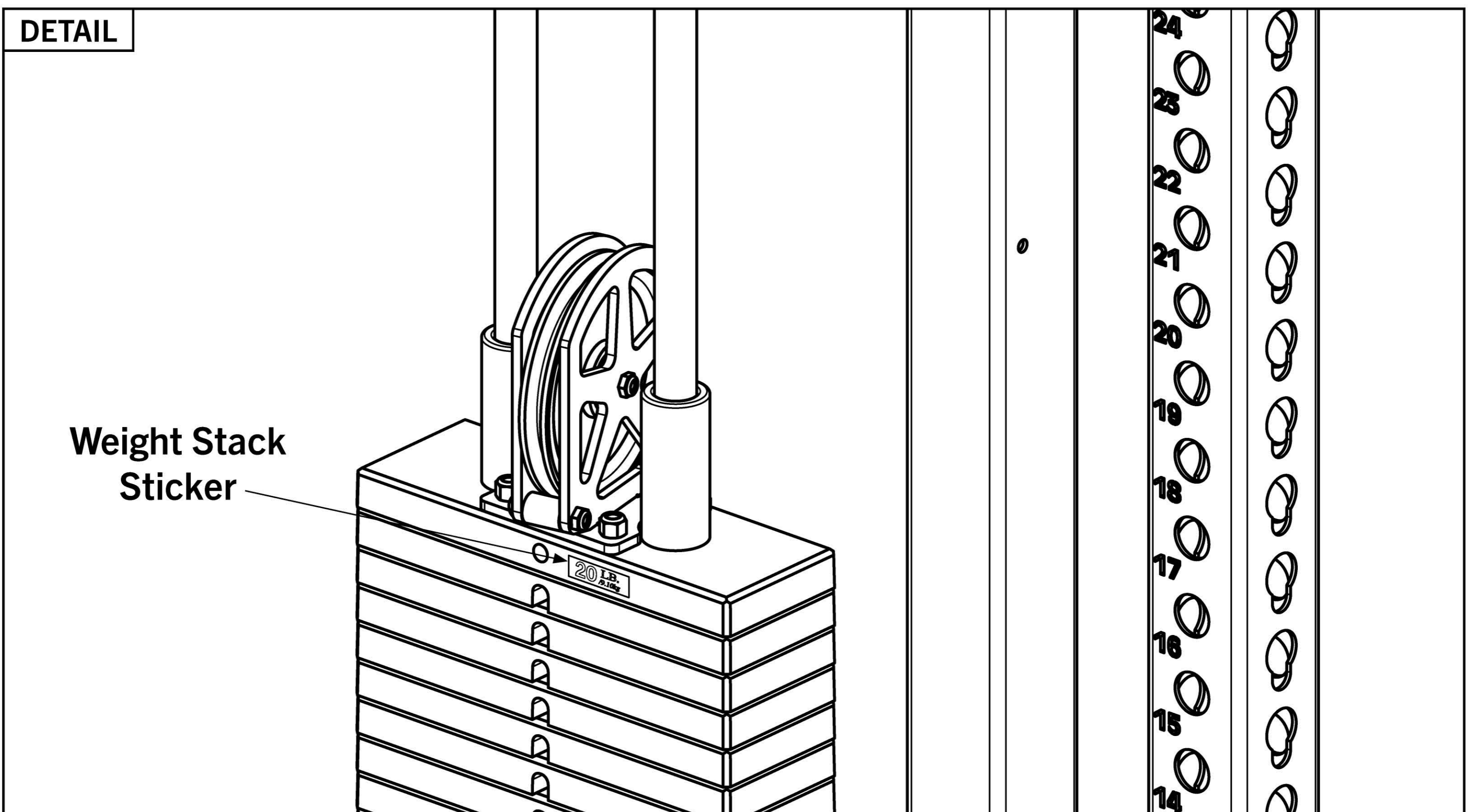
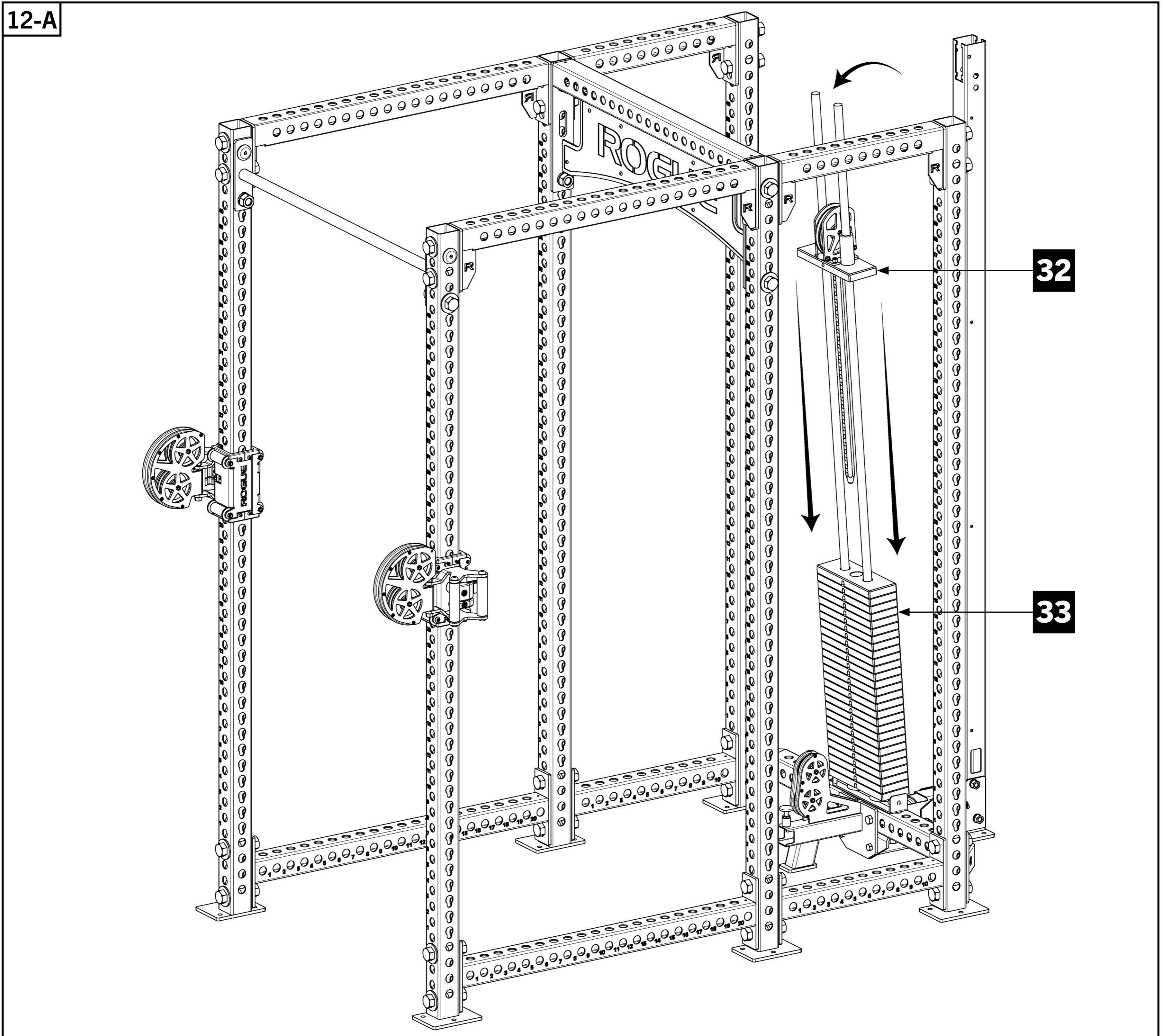

# STEP 13

- Slide Top Weight Stack Stop Block [36] and Guide Rod Spacers [38] down guide rods and rest on top of Weight Stack Stem Pulley as shown.

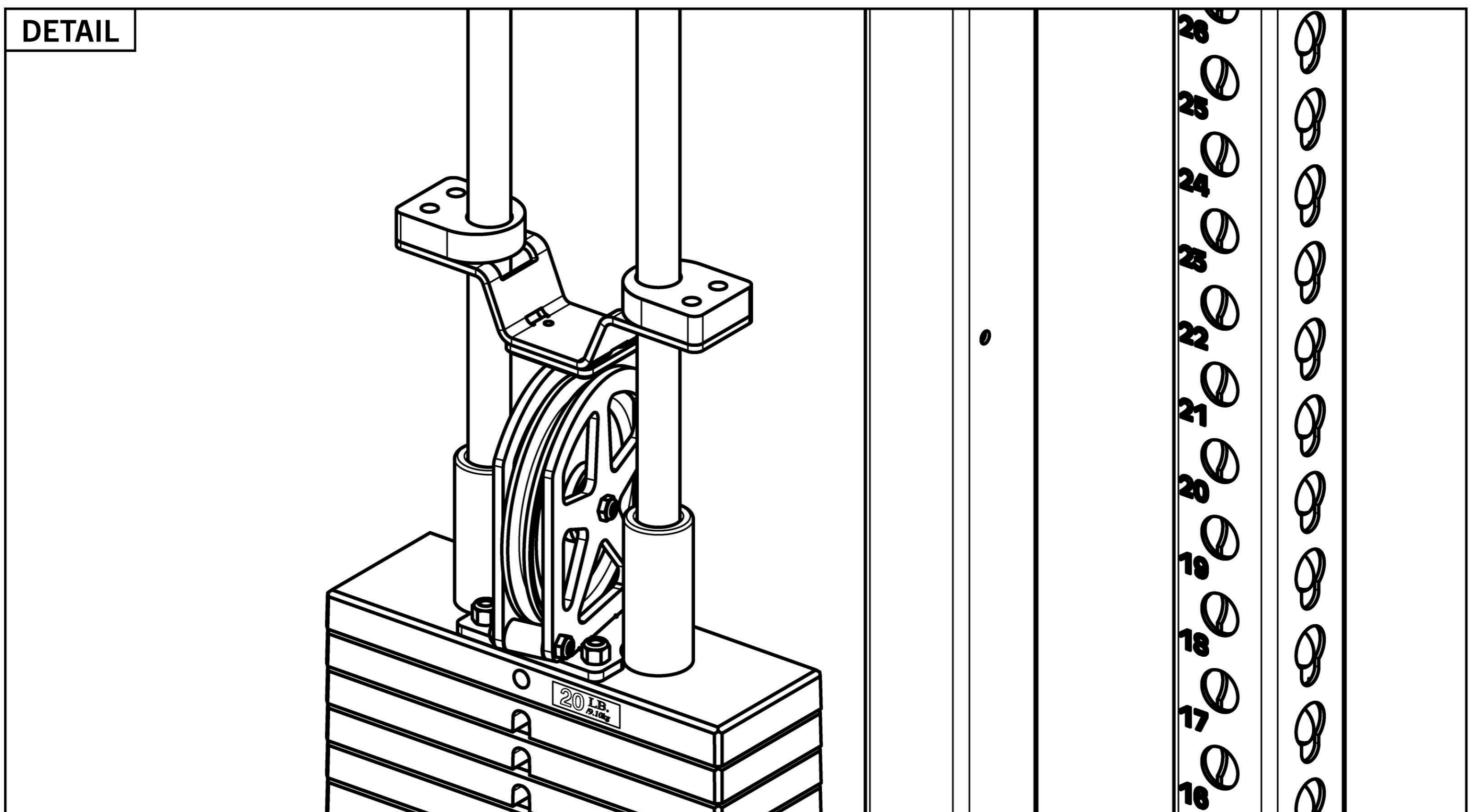
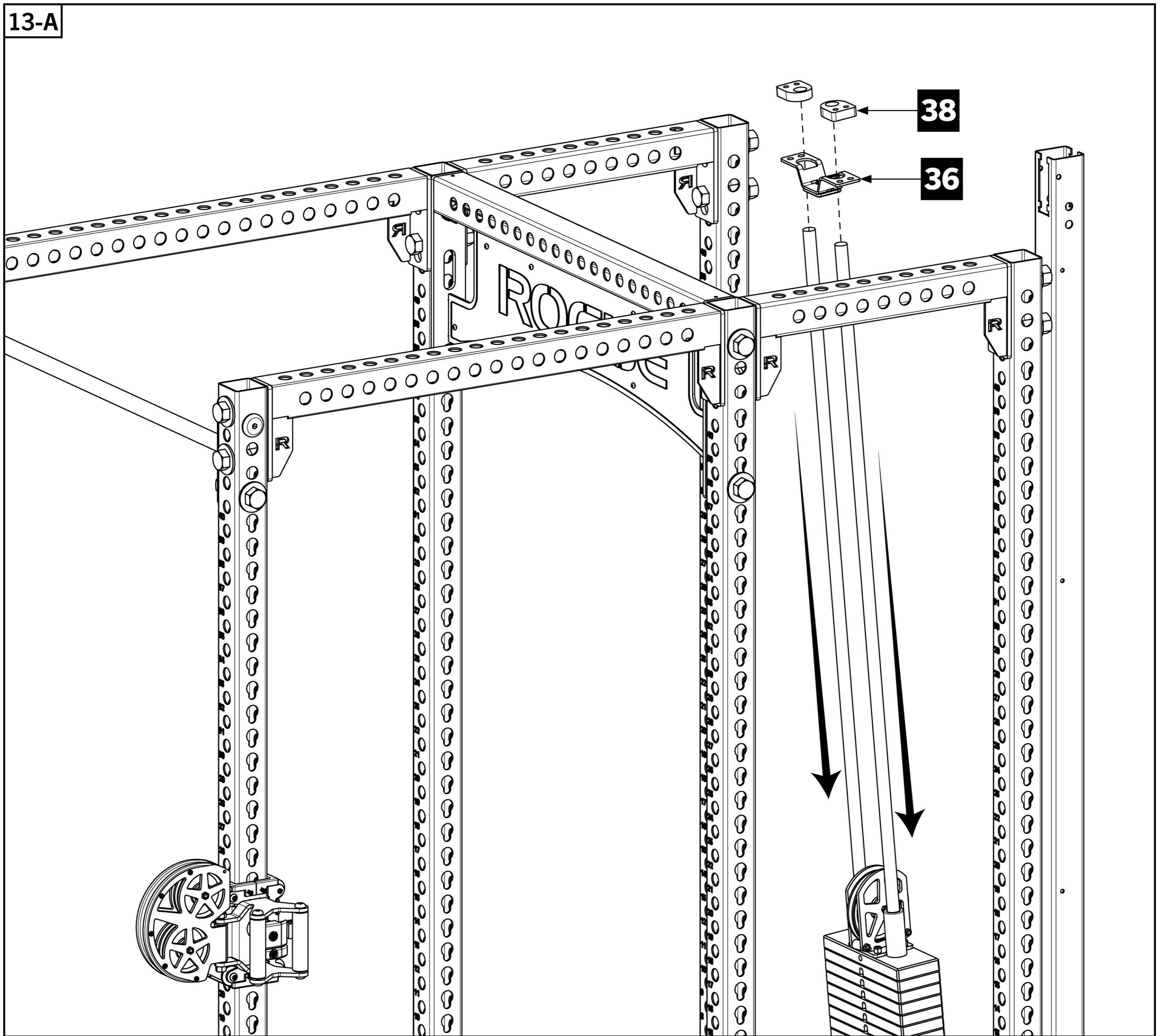

# STEP 14

- Assemble Top Rear Angle Crossmember - RH [22] into position on rear of rack as shown.
- Assemble Top Rear Angle Crossmember - LH [23].
- Ensure Angle Crossmembers are properly locked into Rear 3X3 Upright [17] as shown on next page.

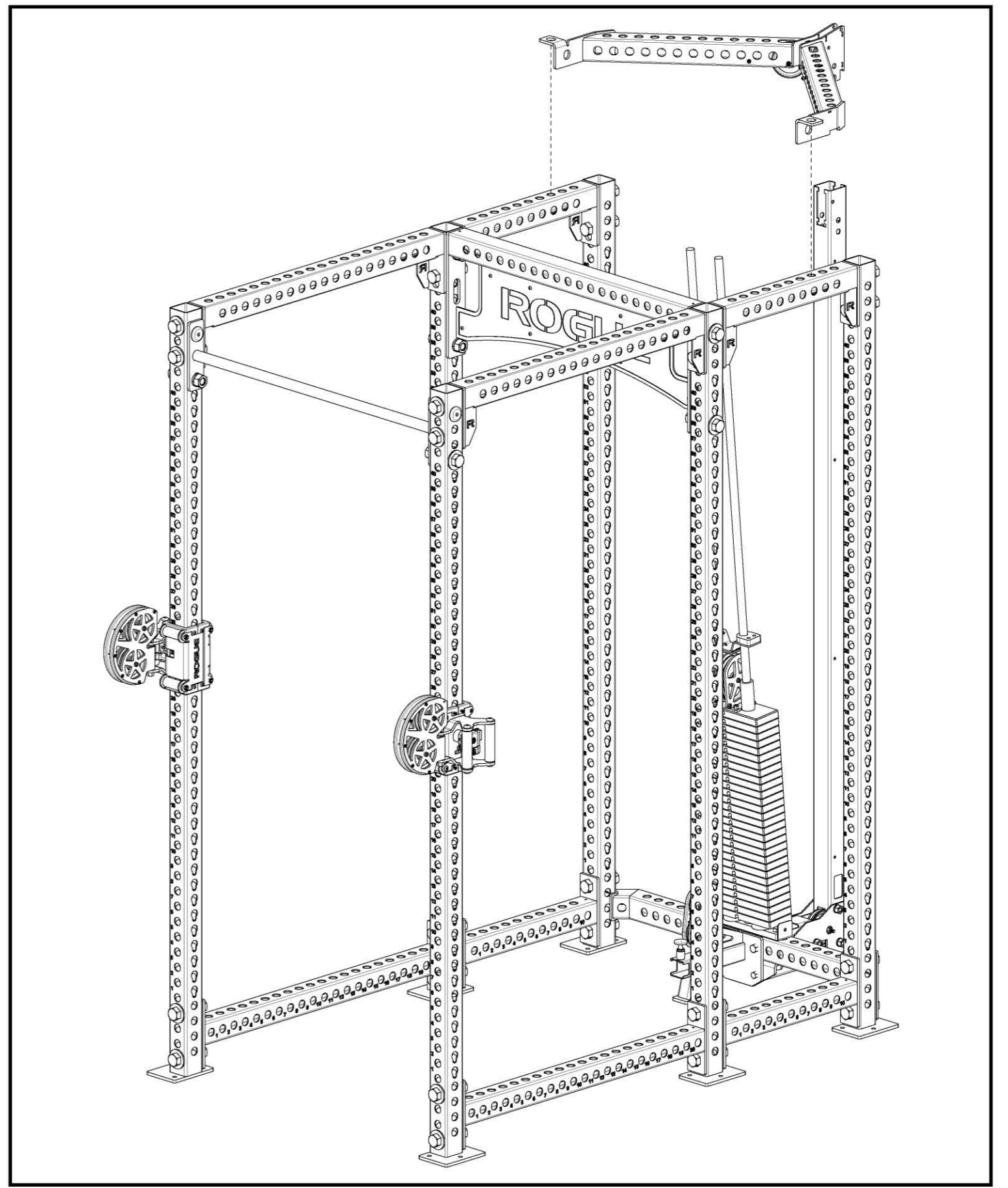

14-A

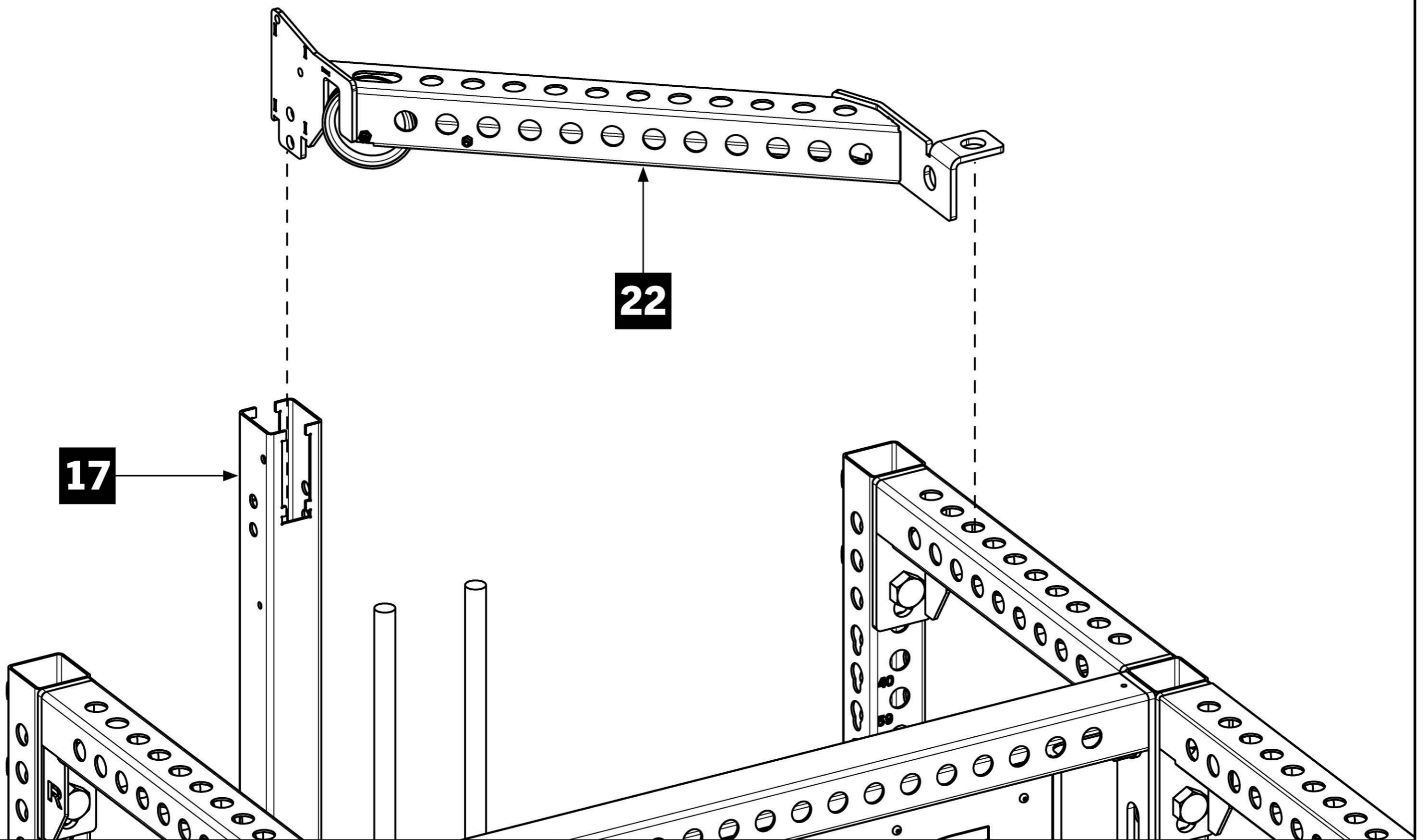

14-B

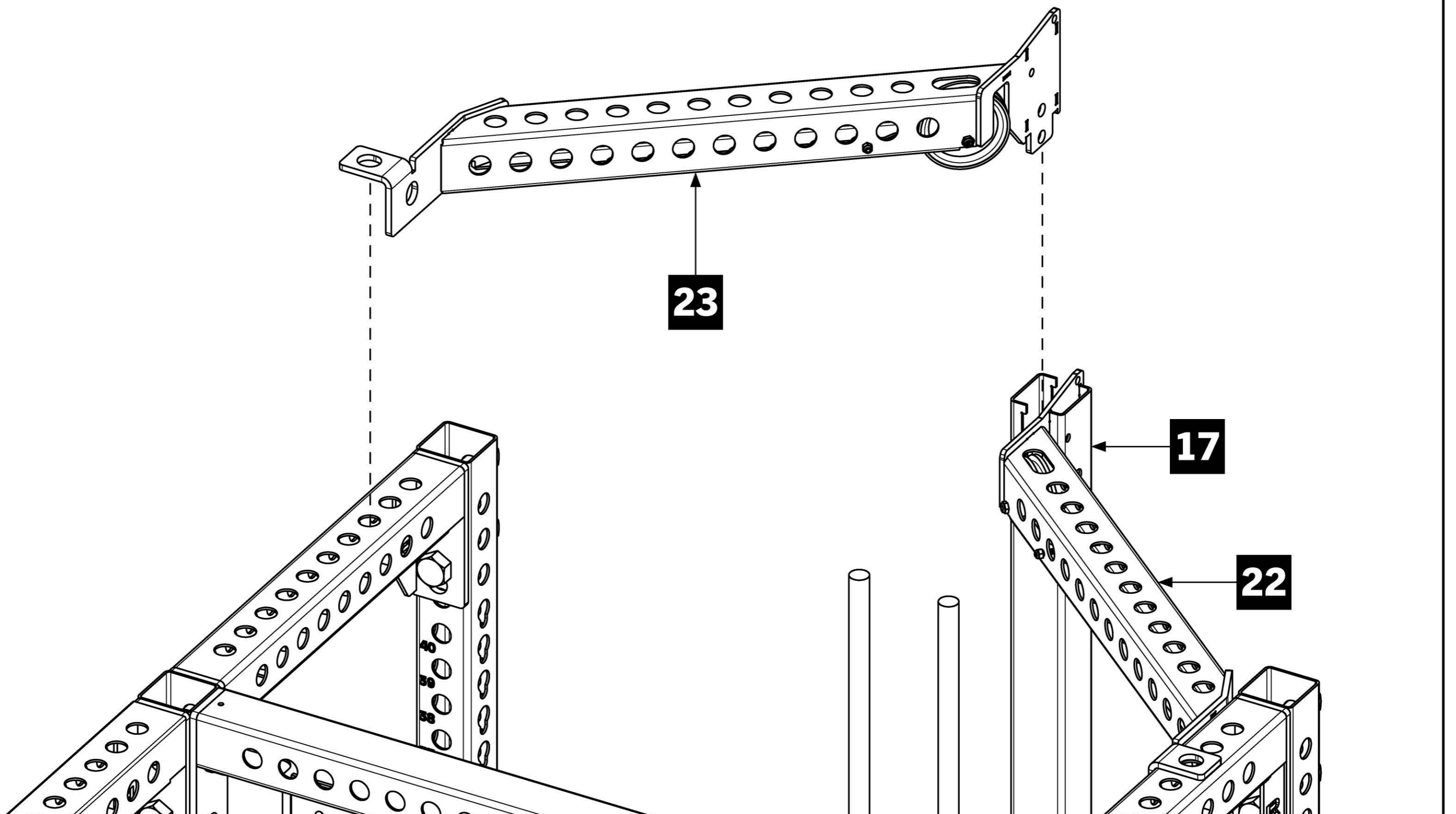

## STEP 14 (CONTINUED)

- **!** Ensure locking tabs on Rear 3X3 Upright are locked into all four slots on each Angle Crossmember by using a down-and-outward sliding motion when dropping the Angle Crossmembers into place.

- Secure Angle Crossmembers to Rear Top Crossmembers using 1" x 5" Hex Bolts [64], Side Shroud Top Brackets [86], 1" Lock Washers [67], and 1" Hex Nuts [68].

### Note:

- Use 1" Flat Washers [66] instead of Side Shroud Top Brackets if Shroud Kit was not purchased.

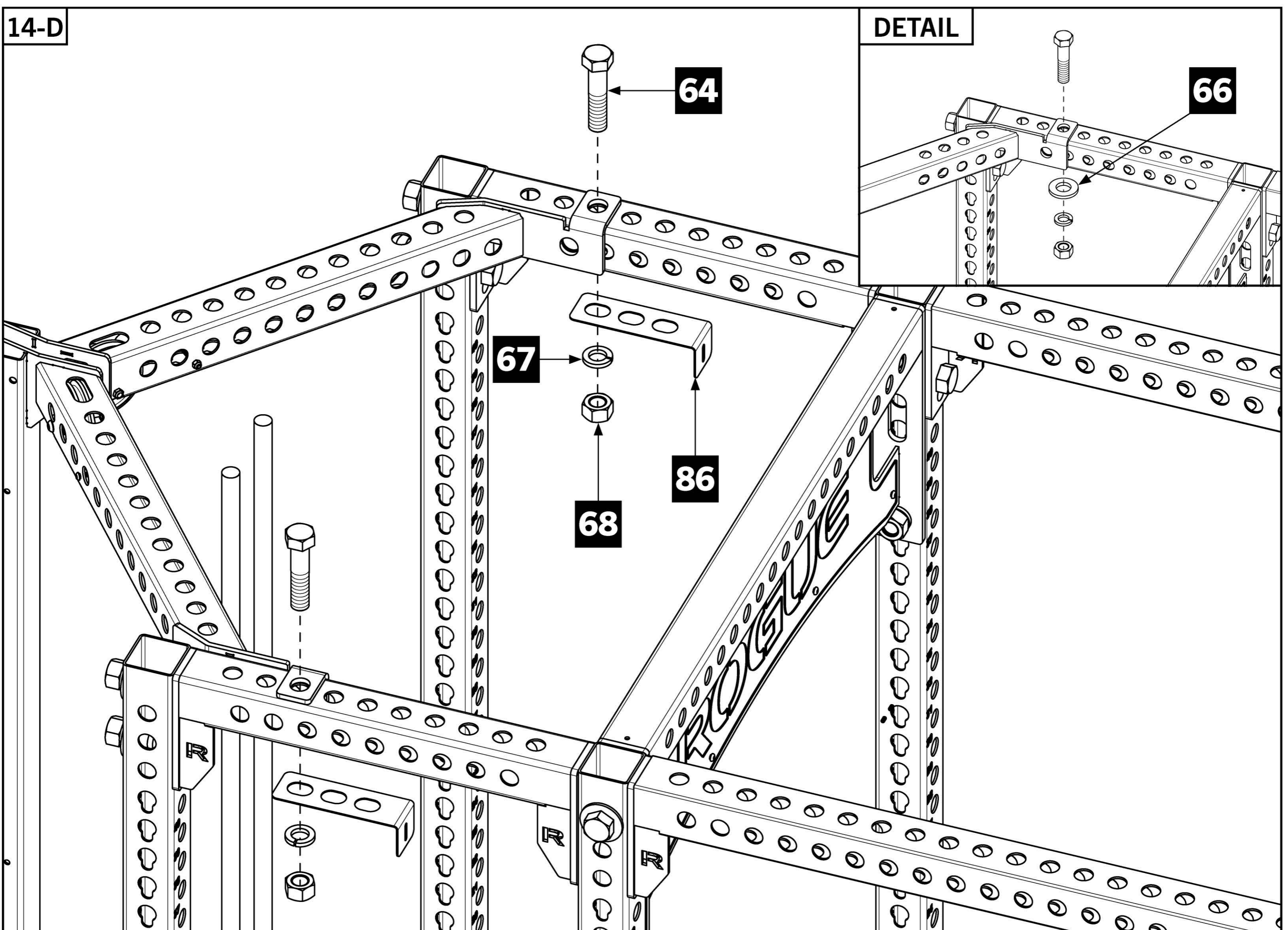
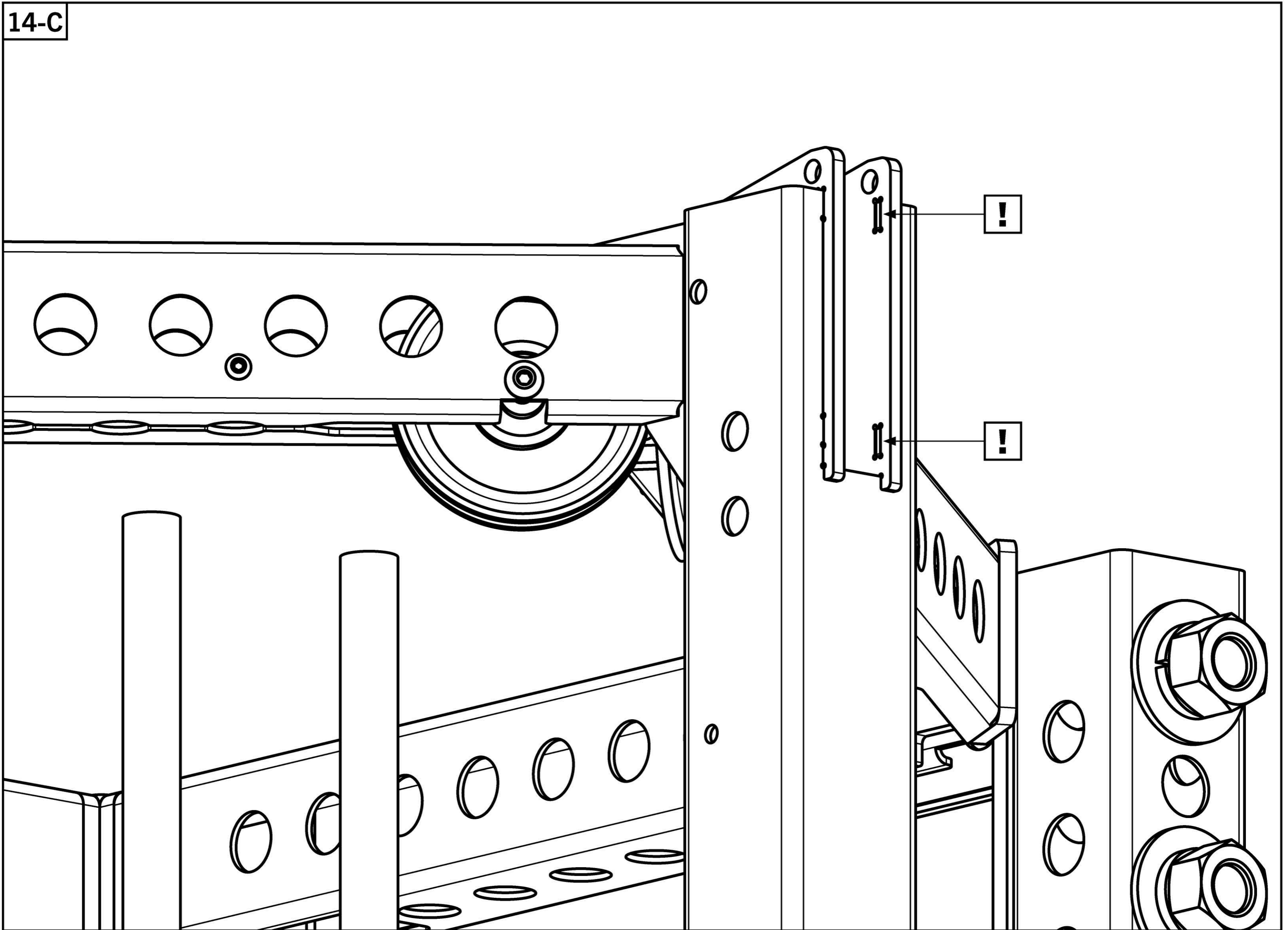

# STEP 15

• Bolt Lat Bar Hanger [27], Lat Pulldown Pulley Bracket [26], and Top Center Crossmember [21] to Nameplate Crossmember [21] using 1" x 5" Hex Bolts [64], 1" Lock Washers [67], and 1" Hex Nuts [68] as shown in 15-A.

• Bolt Top Rear Connector Plates RH [24] and LH [25] to Top Center Crossmember [21] and Rear 3X3 Upright [17] using 5/8" x 4-1/2" Hex Bolts [70], 5/8" Lock Washers [71], and 5/8" Hex Nuts [72].

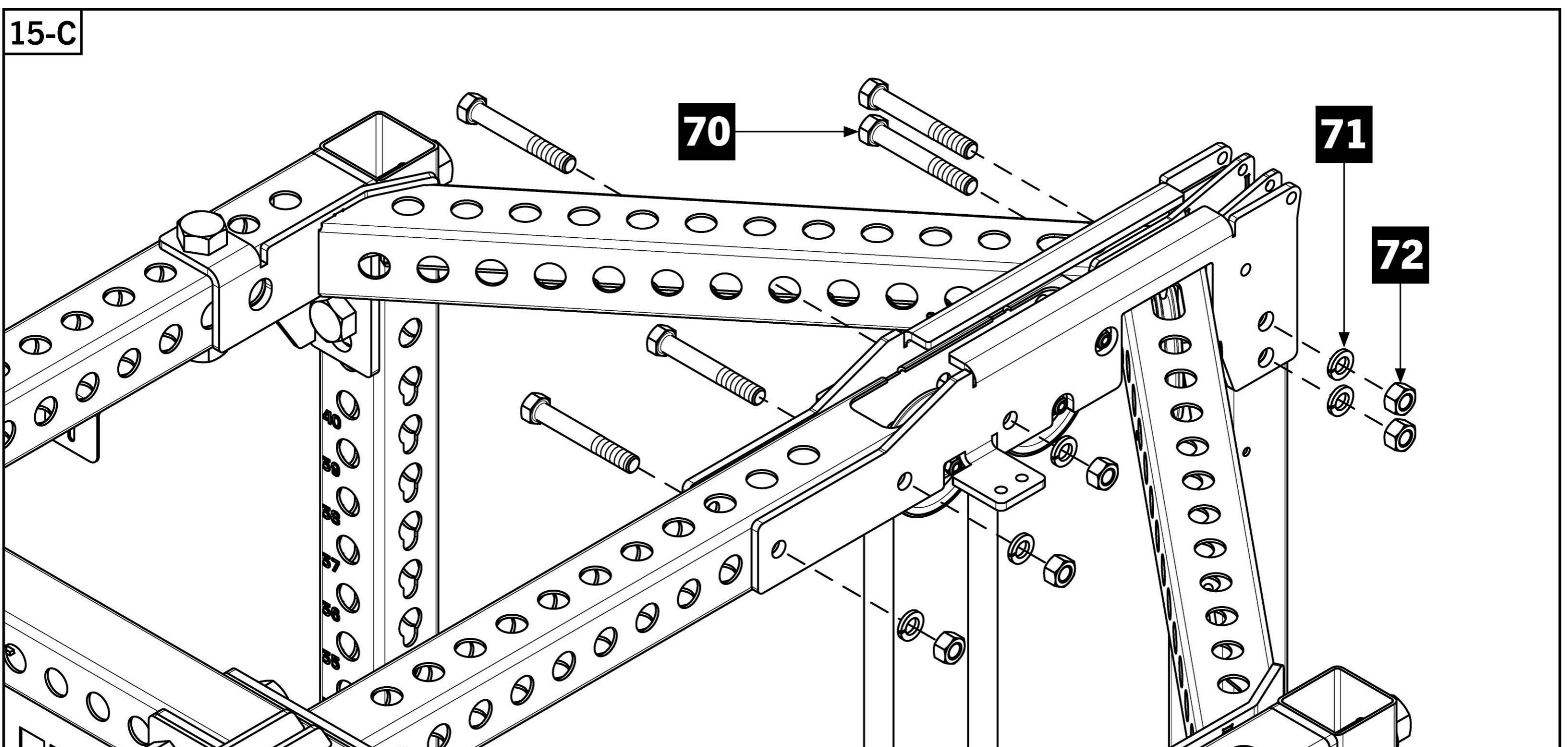
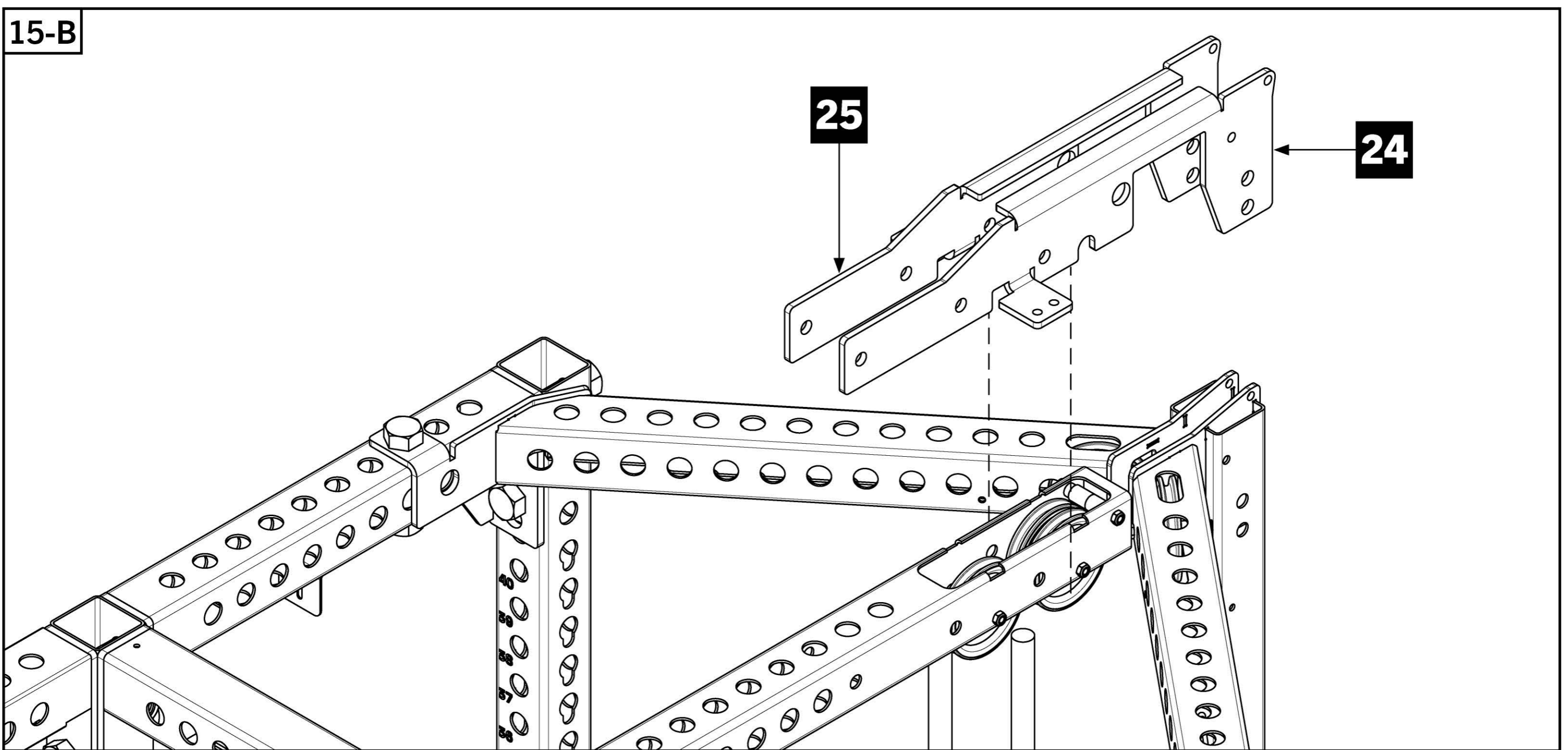
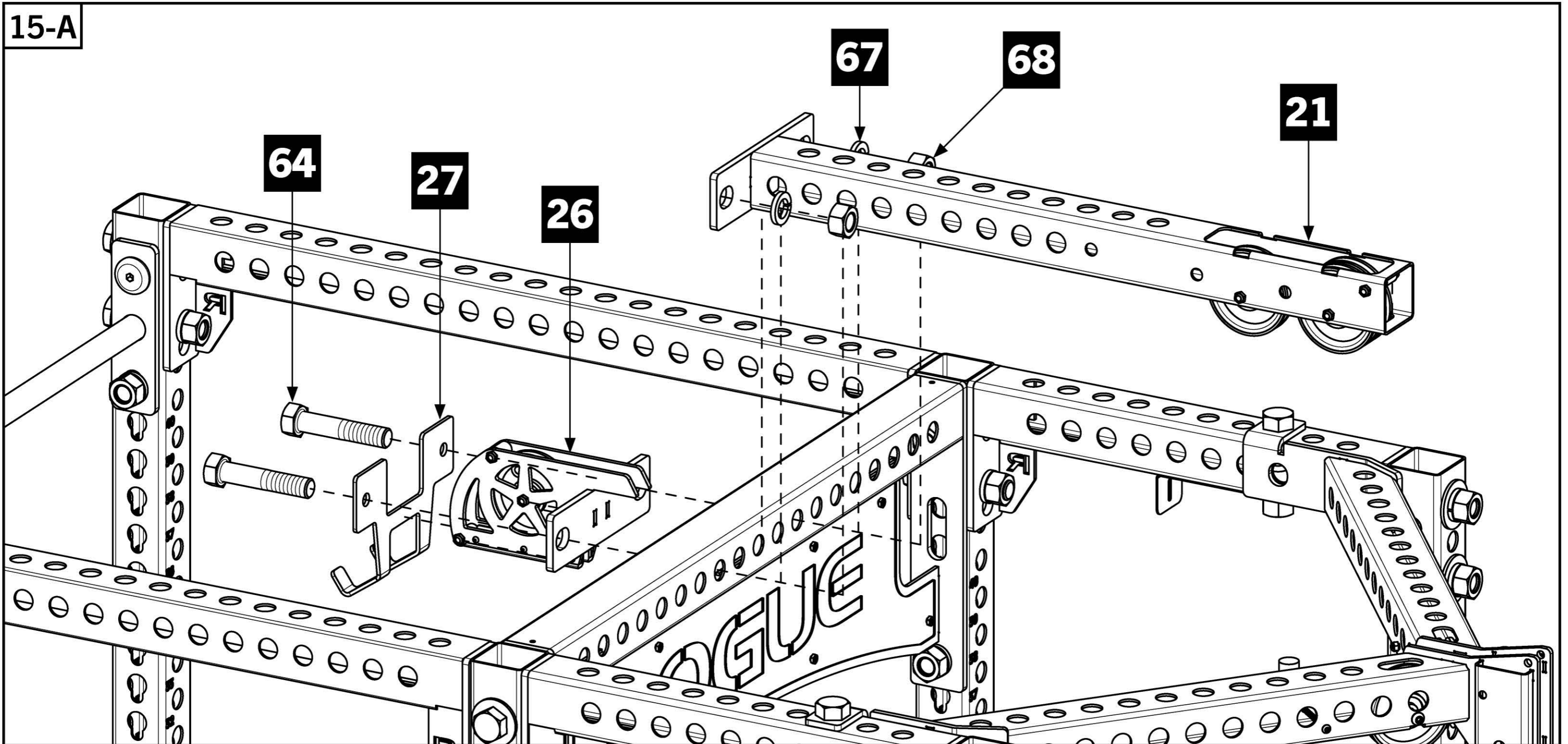

## STEP 16

- Secure 4.5" Pulley [51] and 3/4" x 1" Cable Retainer [52] inside top rear center slot of the of the assembly using 3/8" x 4" Button Head Screws [76] and 3/8" Thin Nylock Nuts [78] through the indicated holes.

- Slide parts assembled in **Step 13** back up to the top of the Guide Rods.

- Bolt Stop Block assembly to indicated holes on Top Rear Connector Plates [24] and [25] using 3/8" x 1.5" Button Head Screws [77] and 3/8" Thin Nylock Nuts [78].

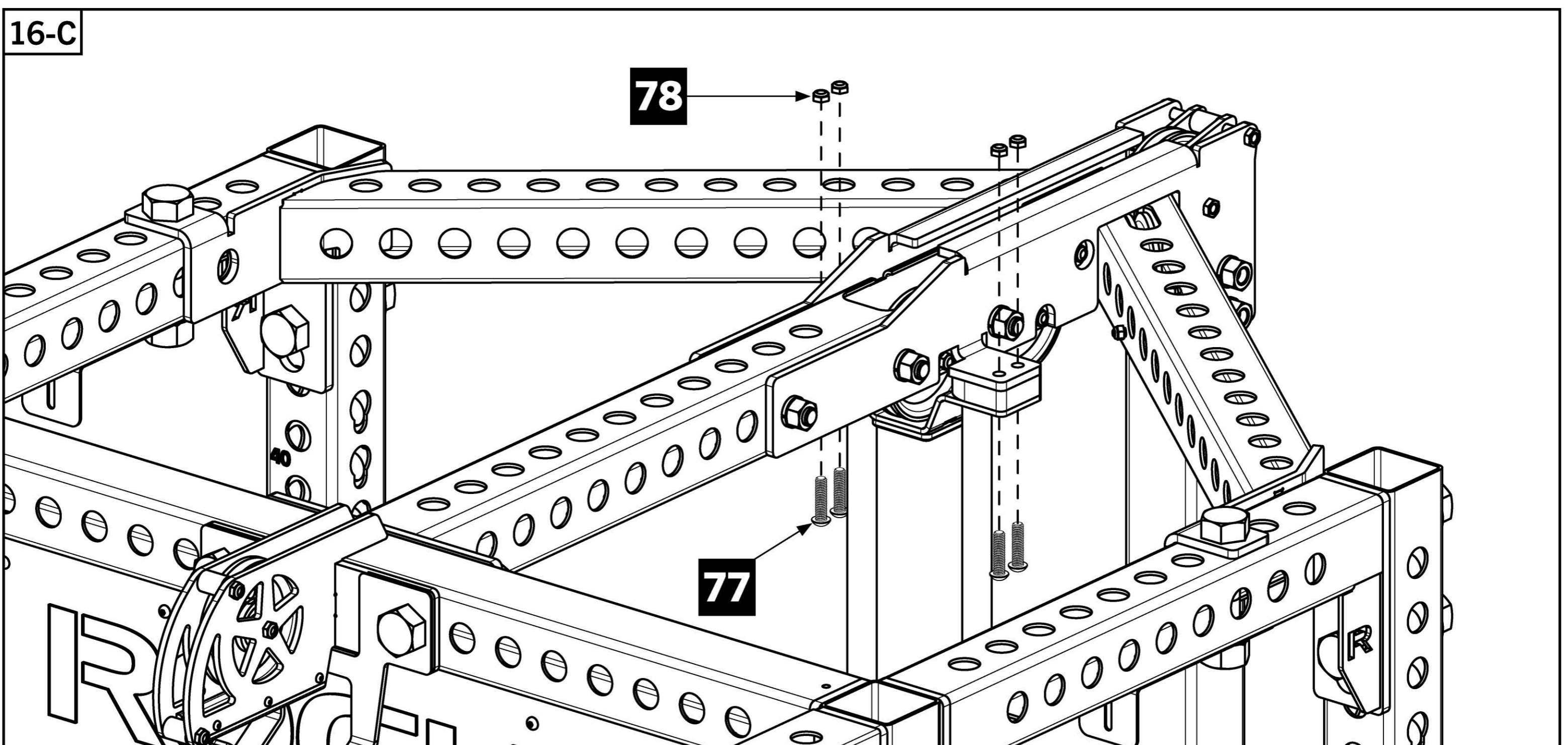
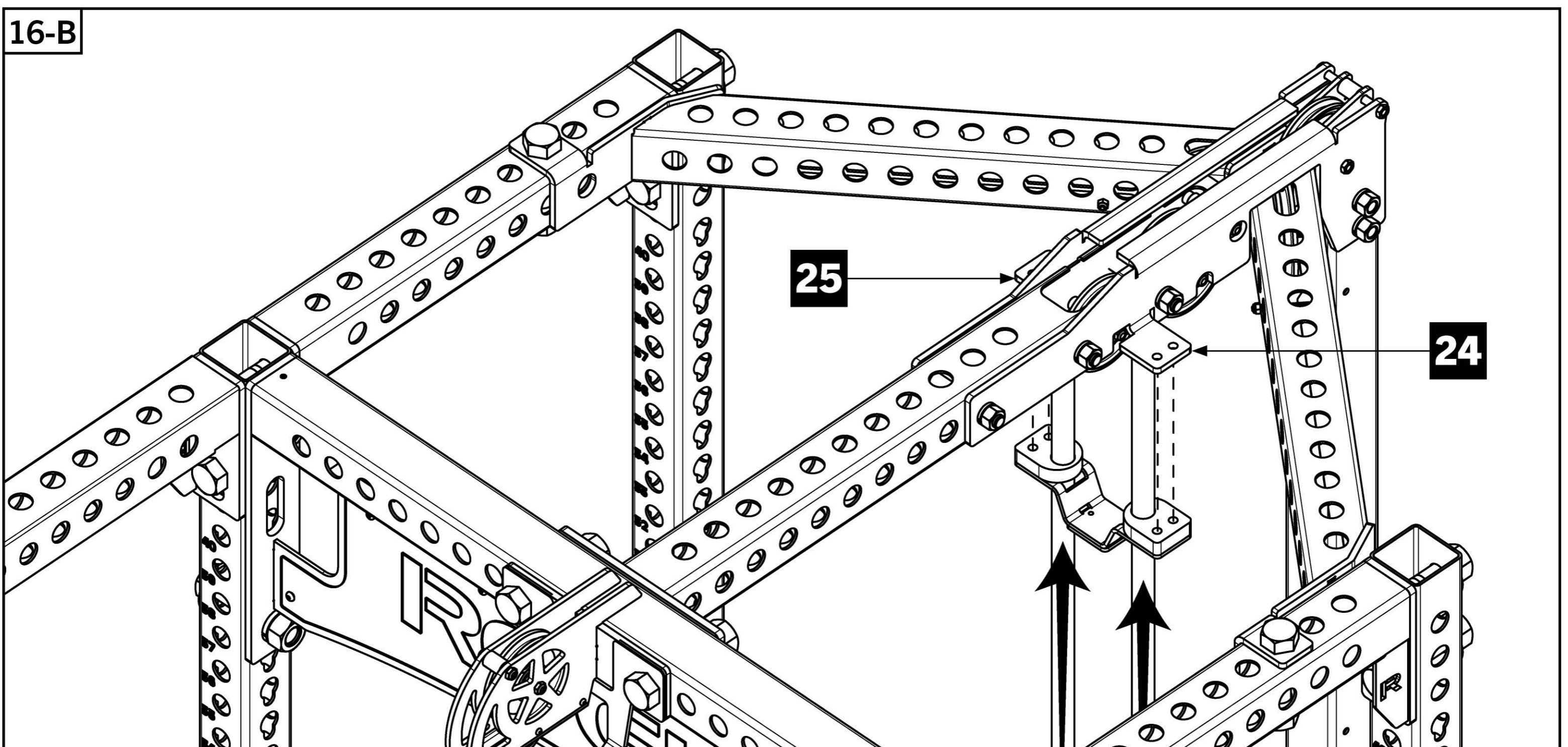
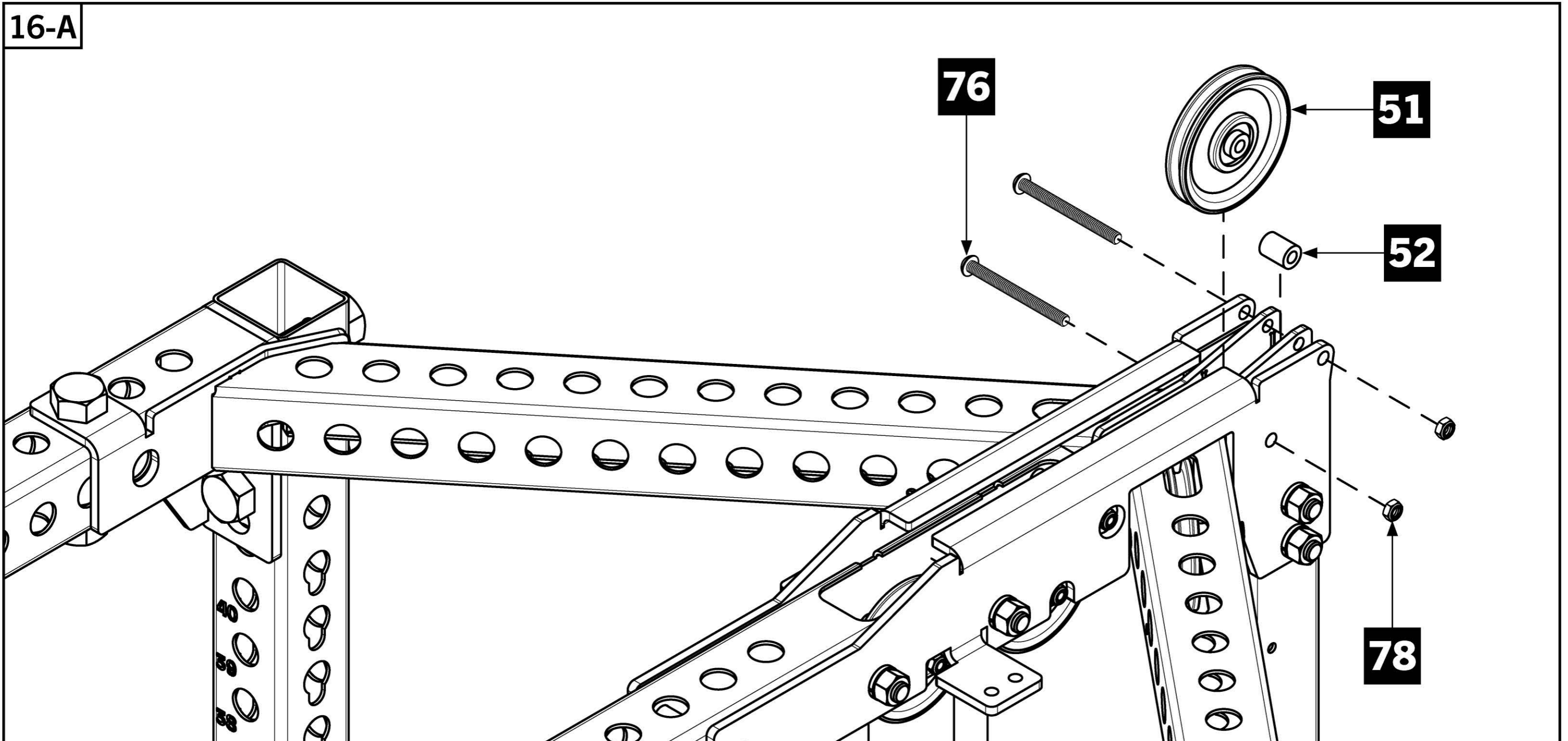

# STEP 17

- Bolt Top Front Side Pulley Assembly - RH [41] and -LH [42] to the Front Top Crossmembers using 1" x 5" Hex Bolts [64], 1" x 3/8" Pulley Bracket Spacers [65], 1" Flat Washers [66], 1" Lock Washers [67], and 1" Hex Nuts [68] as shown.

- **!** 43" Front Top Crossmember is shown. The Top Front Side Pulley Assembly holes utilized will depend on length of your Front Crossmembers. Use the diagram below to determine which holes to use.

### Note:

- Bolt hardware through the first and third holes on your Front Top Crossmembers [2] regardless of crossmember length.

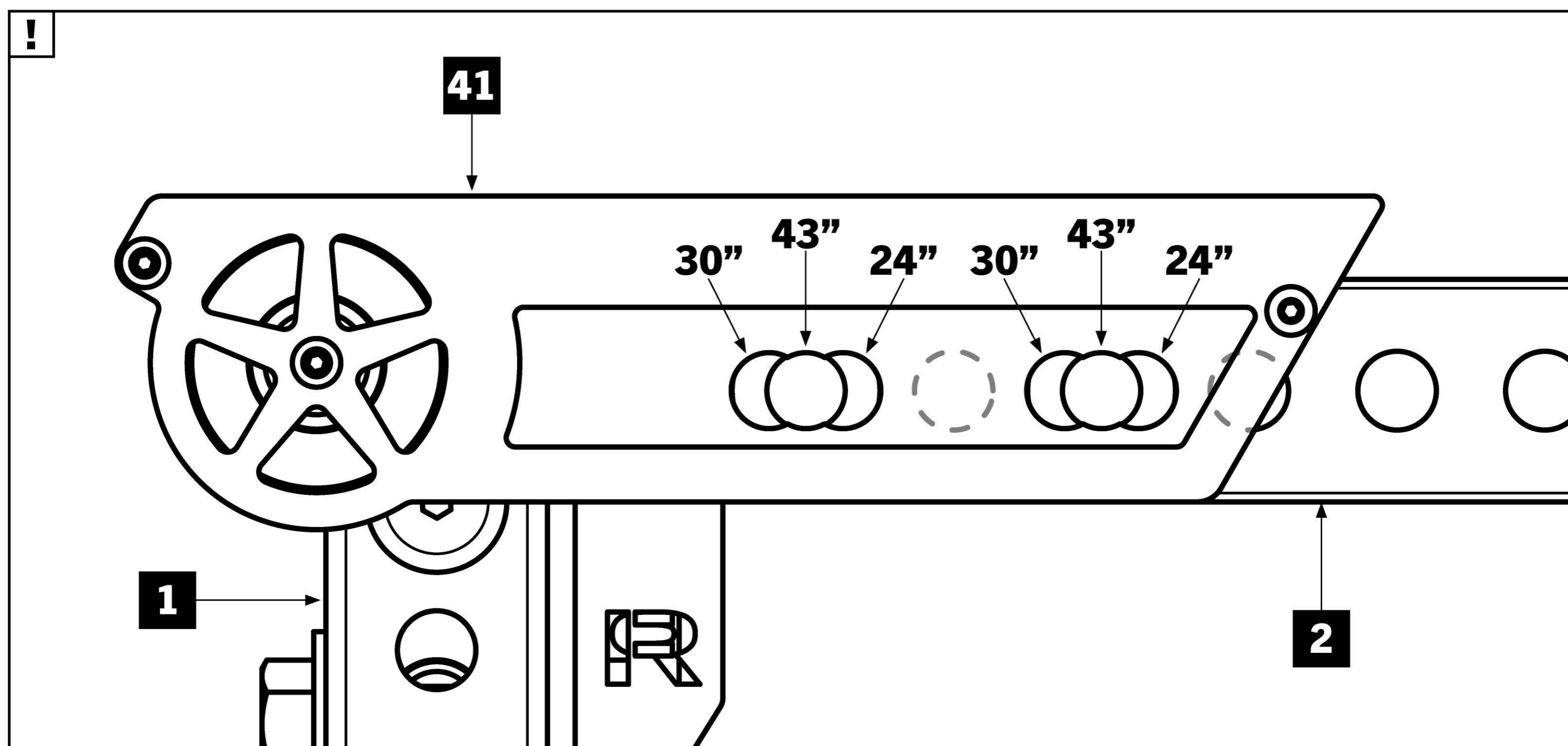
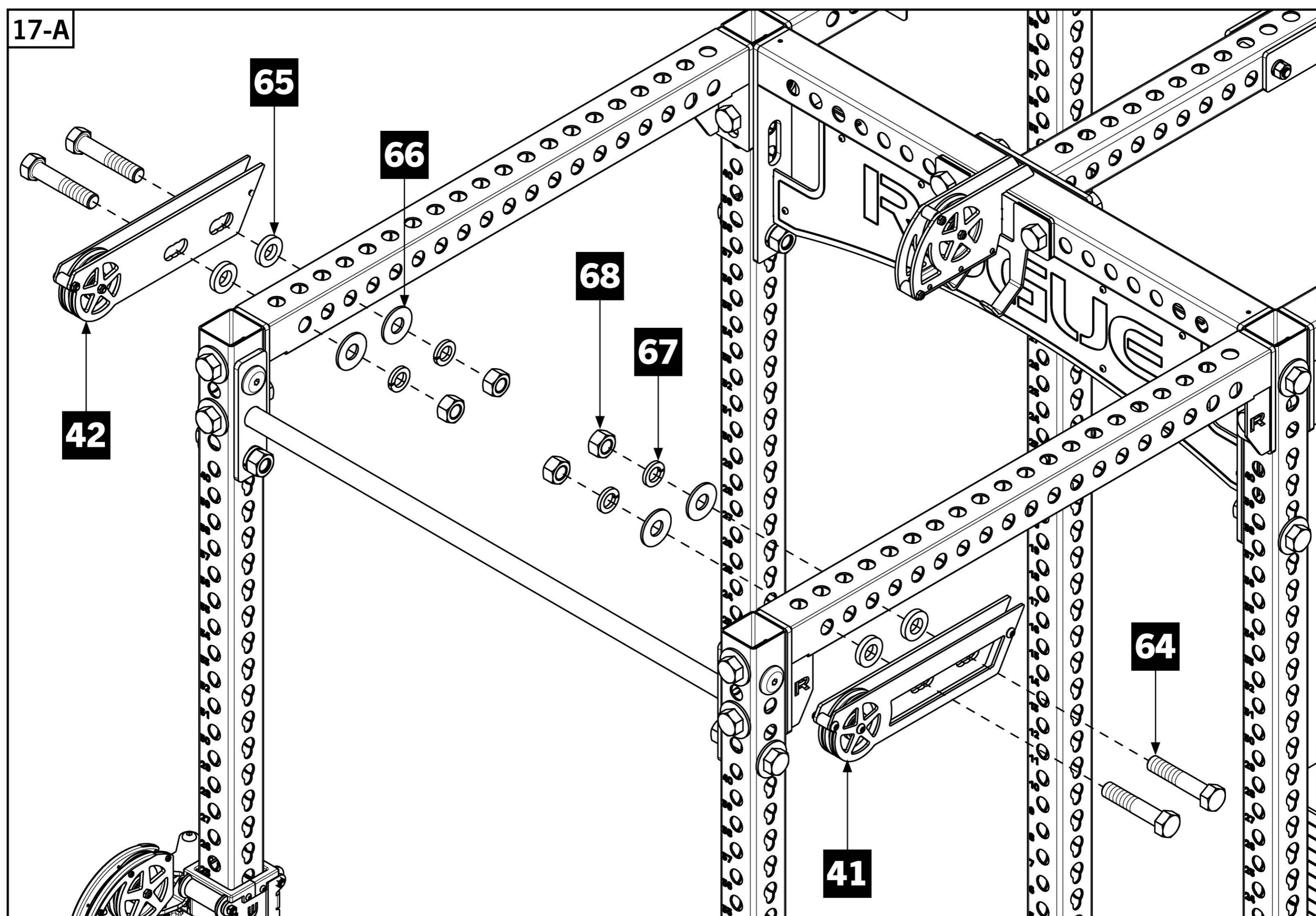
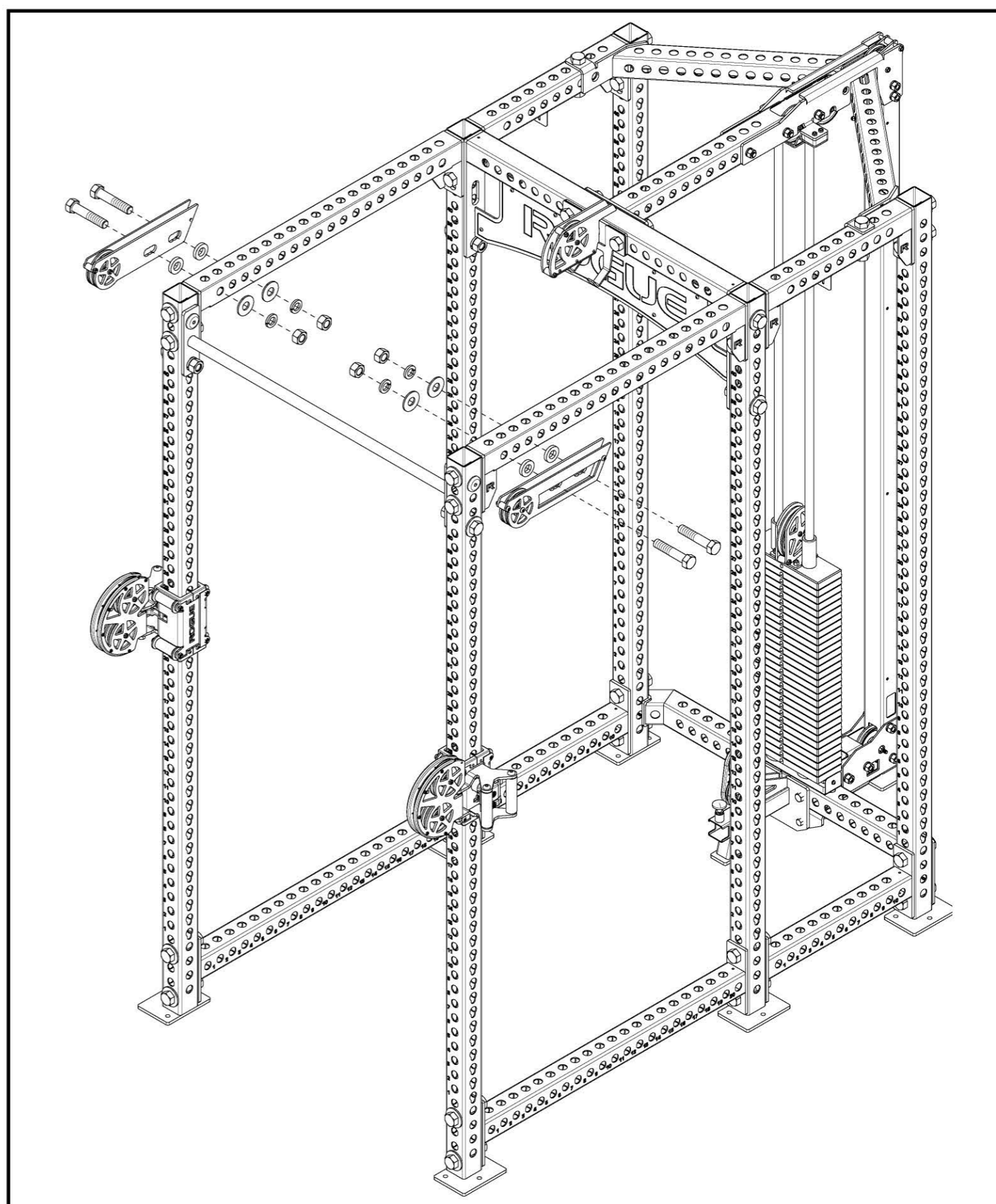

# STEP 18

- Bolt Top Rear Side Pulley Assembly - RH [43] and -LH [44] to the 24" Rear Top Crossmembers [4] using 1" x 5" Hex Bolts [64], 1" x 3/8" Pulley Bracket Spacers [65], 1" Flat Washers [66], 1" Lock Washers [67], and 1" Hex Nuts [68] as shown.

- Ensure the rear hardware is assembled through the indicated hole on Top Rear Angled Crossmembers.

### Note:

- Only two 1" Flat Washers used on this step. Do not use Flat Washers on the rear hardware assemblies.
- Tip: it is easiest to assemble this step by inserting the front hardware first and then swinging the back of Side Pulley Assemblies up to install the rear hardware.

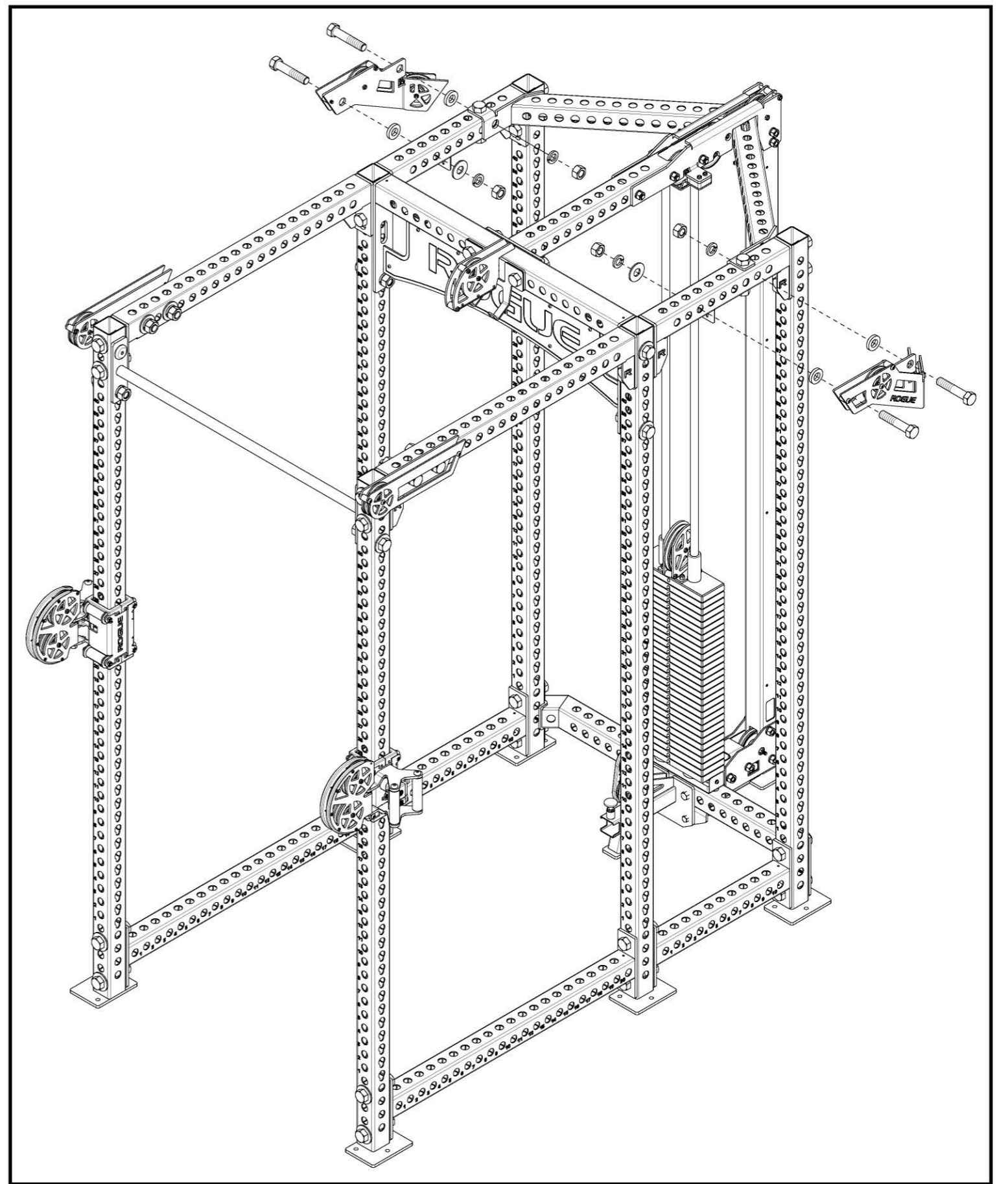

18-A

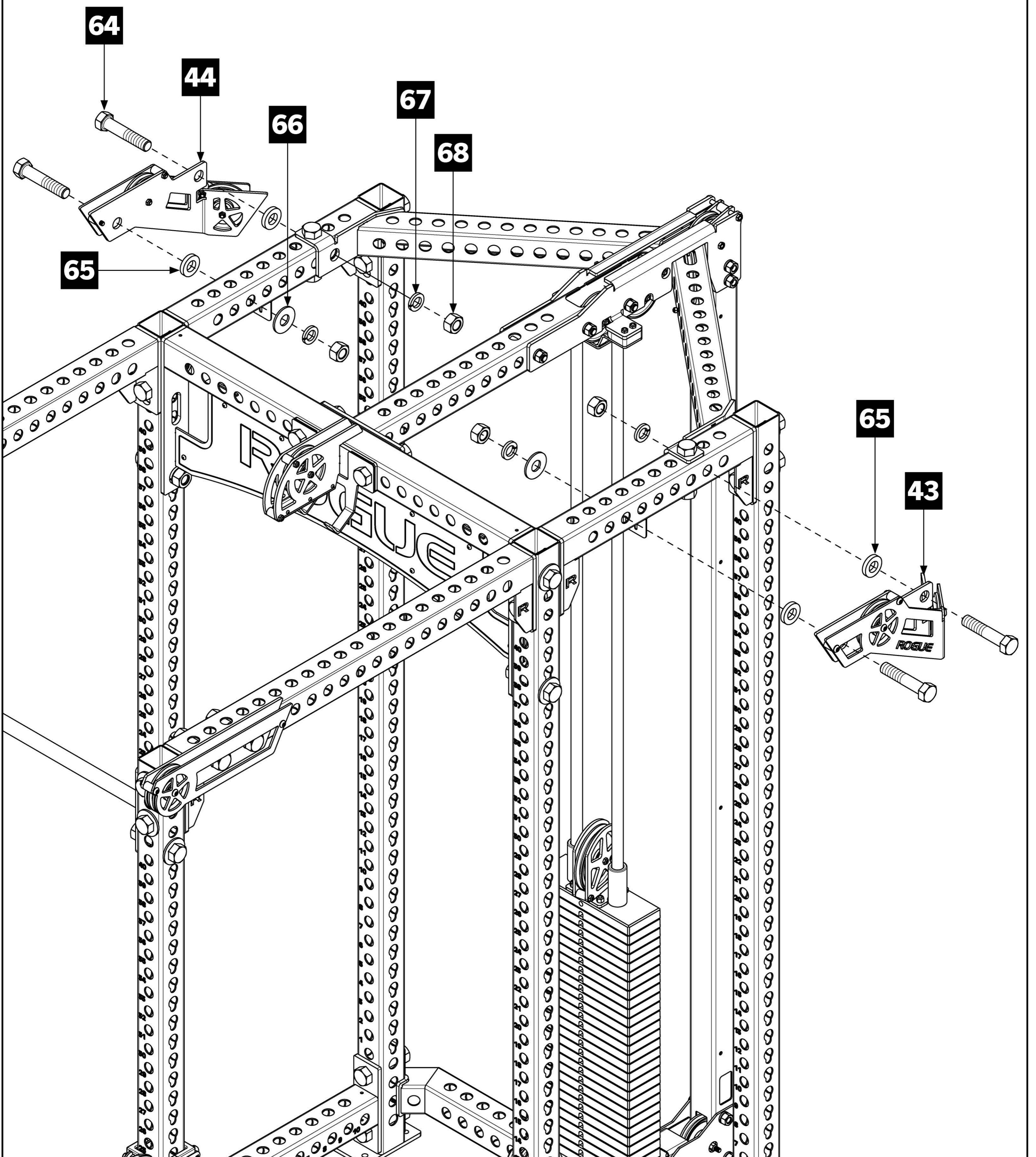



# STEP 19

- Bolt Bottom Front Side Pulley Assembly - RH [45] and -LH [46] to the Front Low Crossmembers using 1" x 5" Hex Bolts [64], 1" x 3/8" Pulley Bracket Spacers [65], 1" Flat Washers [66], 1" Lock Washers [67], and 1" Hex Nuts [68] as shown.

- **!** 43" Front Top Crossmember is shown. The Bottom Front Side Pulley Assembly holes utilized will depend on length of your Front Crossmembers. Use the diagram below to determine which holes to use.

**Note:**

- Bolt hardware through the holes between number cutouts '4' & '5' and '6' & '7' on your Front Low Crossmembers [3].
- Bolt heads should be oriented on the inside of rack as shown.

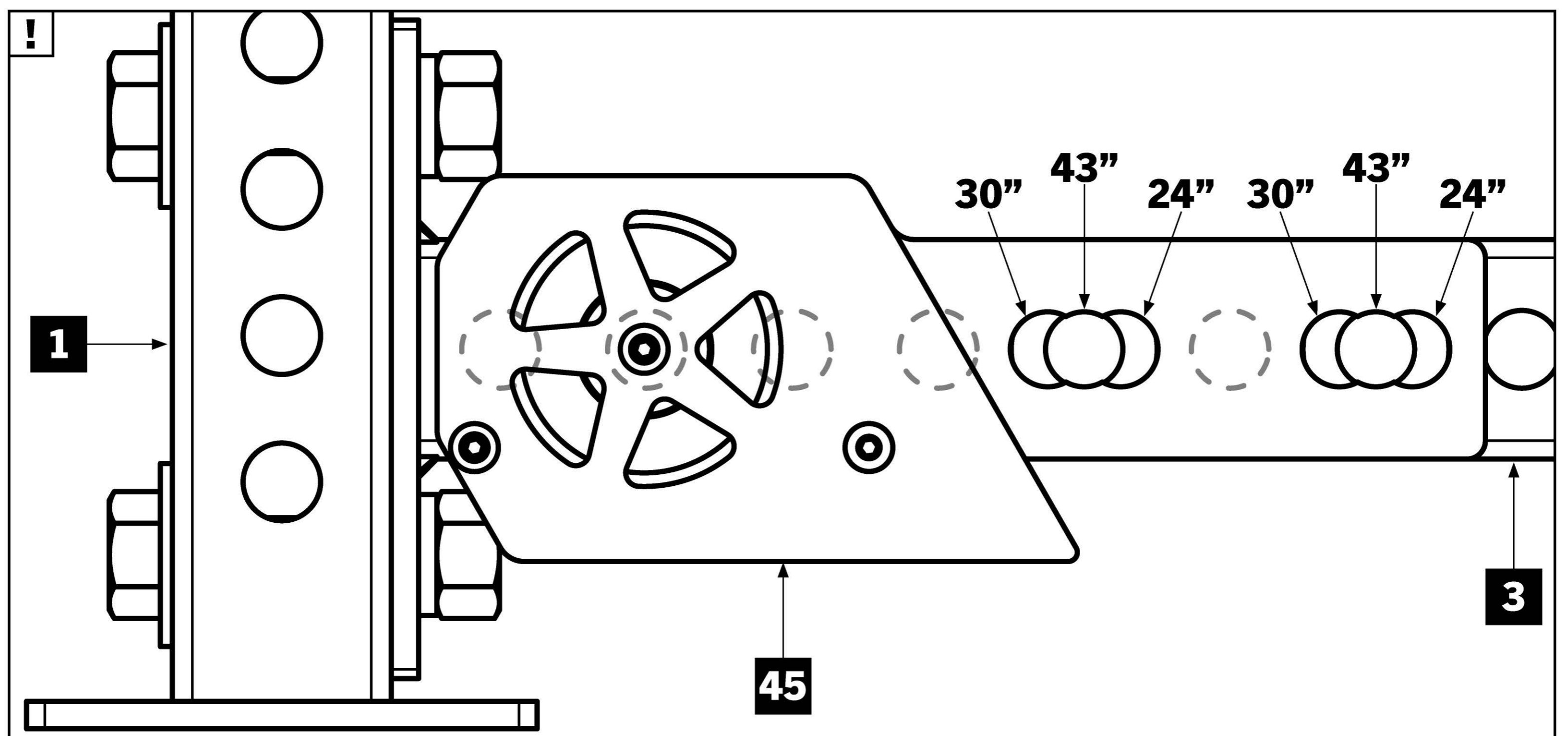
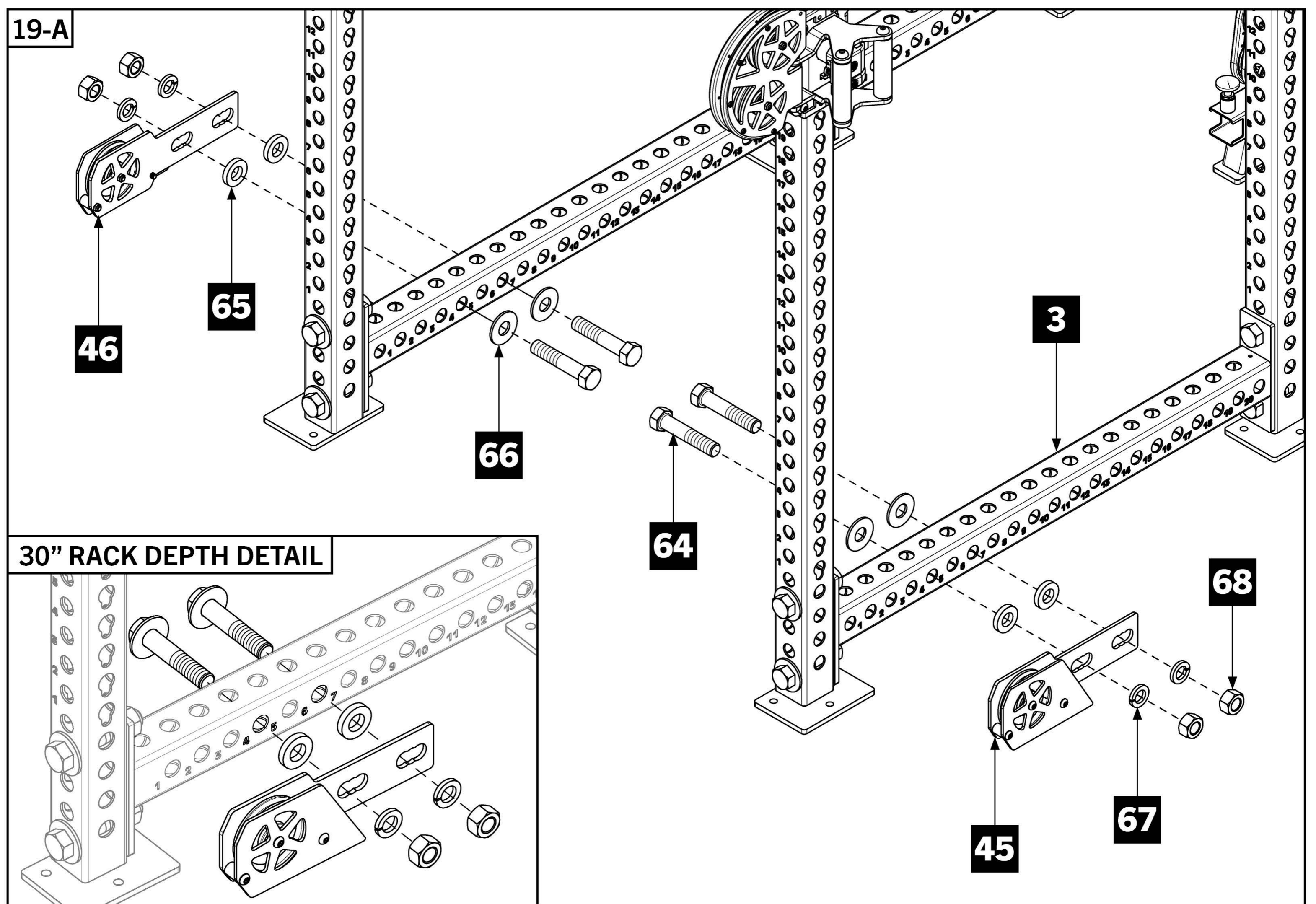
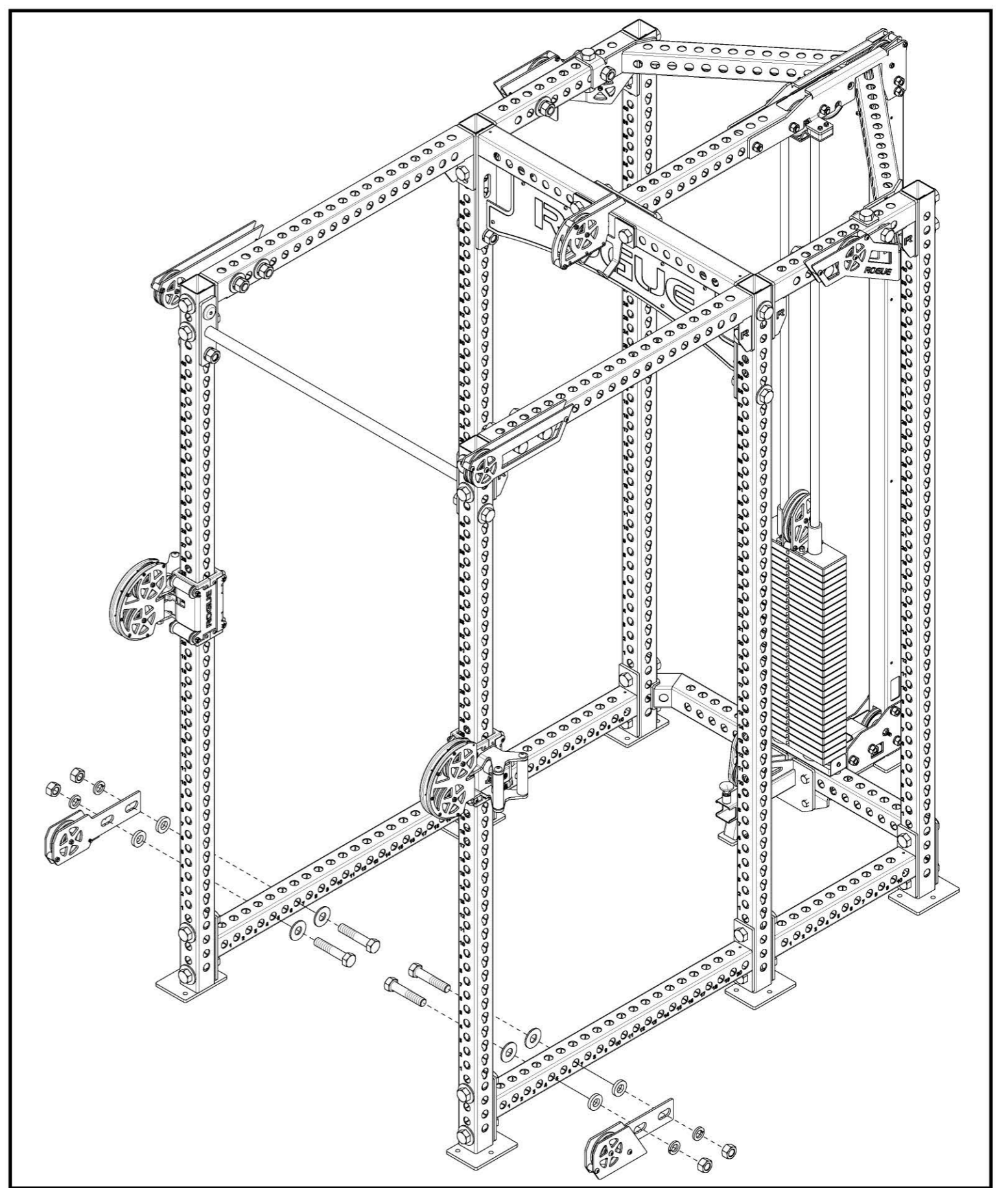

## STEP 20

- Bolt Bottom Rear Side Pulley Assembly - RH [47] and -LH [48] to the 24" Rear Low Crossmembers using 1" x 5" Hex Bolts [64], 1" x 3/8" Pulley Bracket Spacers [65], 1" Flat Washers [66], 1" Lock Washers [67], and 1" Hex Nuts [68] as shown.

### Note:

- Hardware is assembled through the 3rd and 9th holes on 24" Rear Low Crossmembers [5] with the bolt heads oriented inside of rack as shown.

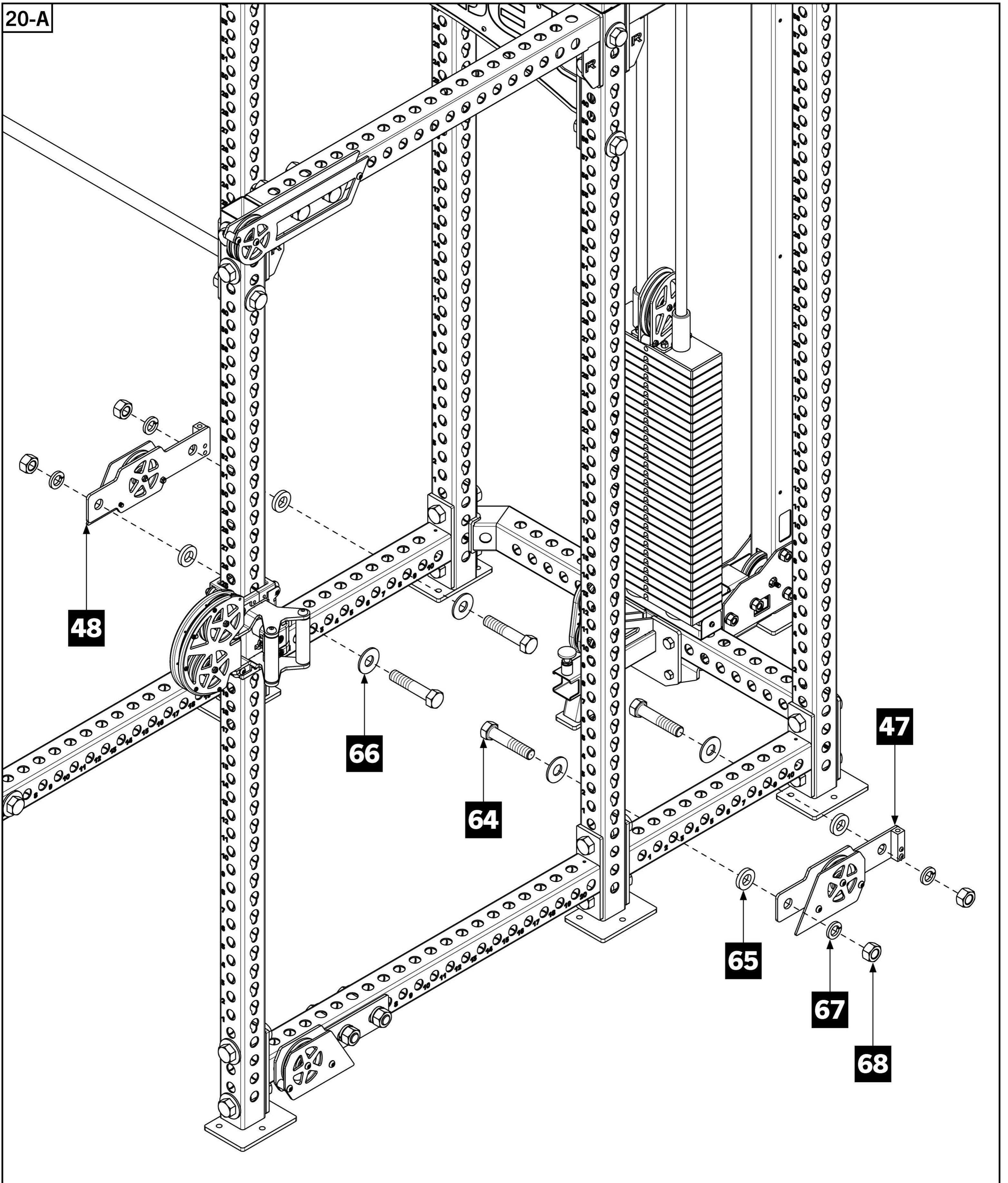
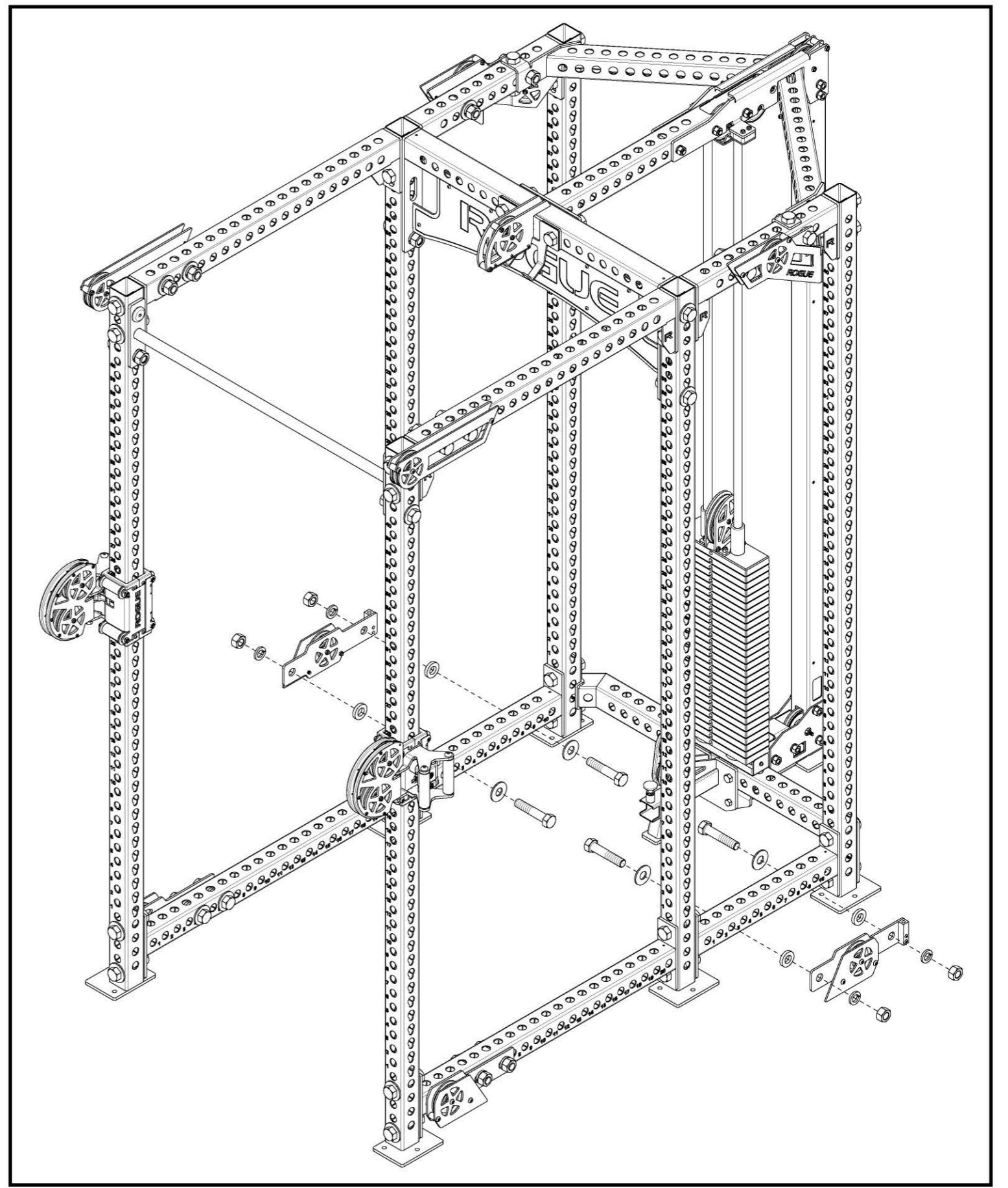

# STEP 21

## Note:

- Completely unwind and straighten out Trolley/Trolley Cable [53] to remove any twists/kinks prior to installation.
- The blue arrows shown in **STEP 21** through **STEP 26** indicate directions for assembling the Trolley/Trolley Cable and correspond with the blue tag on the Ball End of cable.
- Feed the Ball End of Trolley/Trolley Cable [53] between the two pulleys inside Swivel Trolley RH [19] and continue upward.
- Feed the cable around pulley inside the Top Front Side Pulley Assembly - RH [41] and continue toward the back of the rack.
- Continue around the first pulley on Top Rear Side Pulley Assembly - RH [43] and then downward.

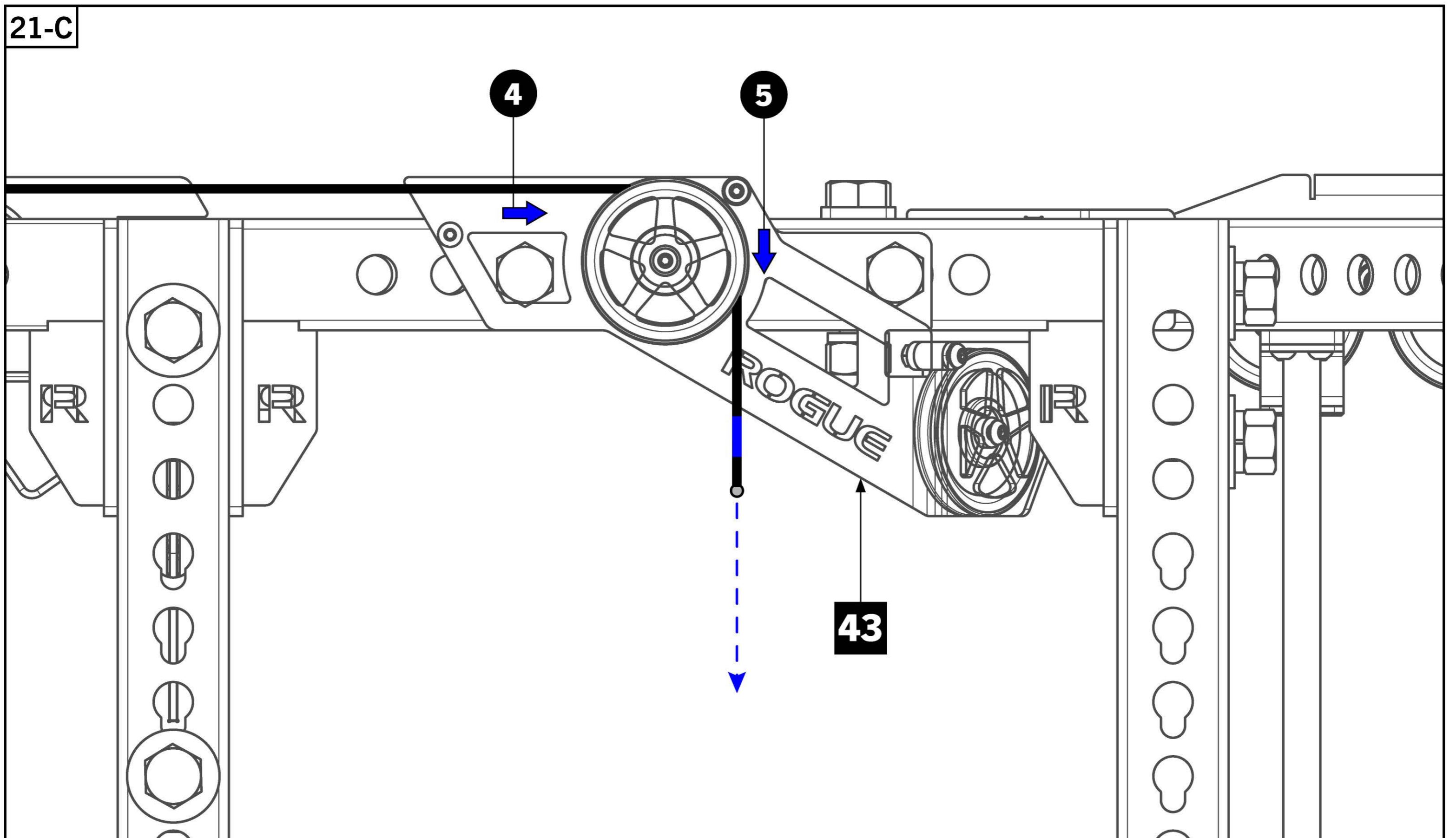
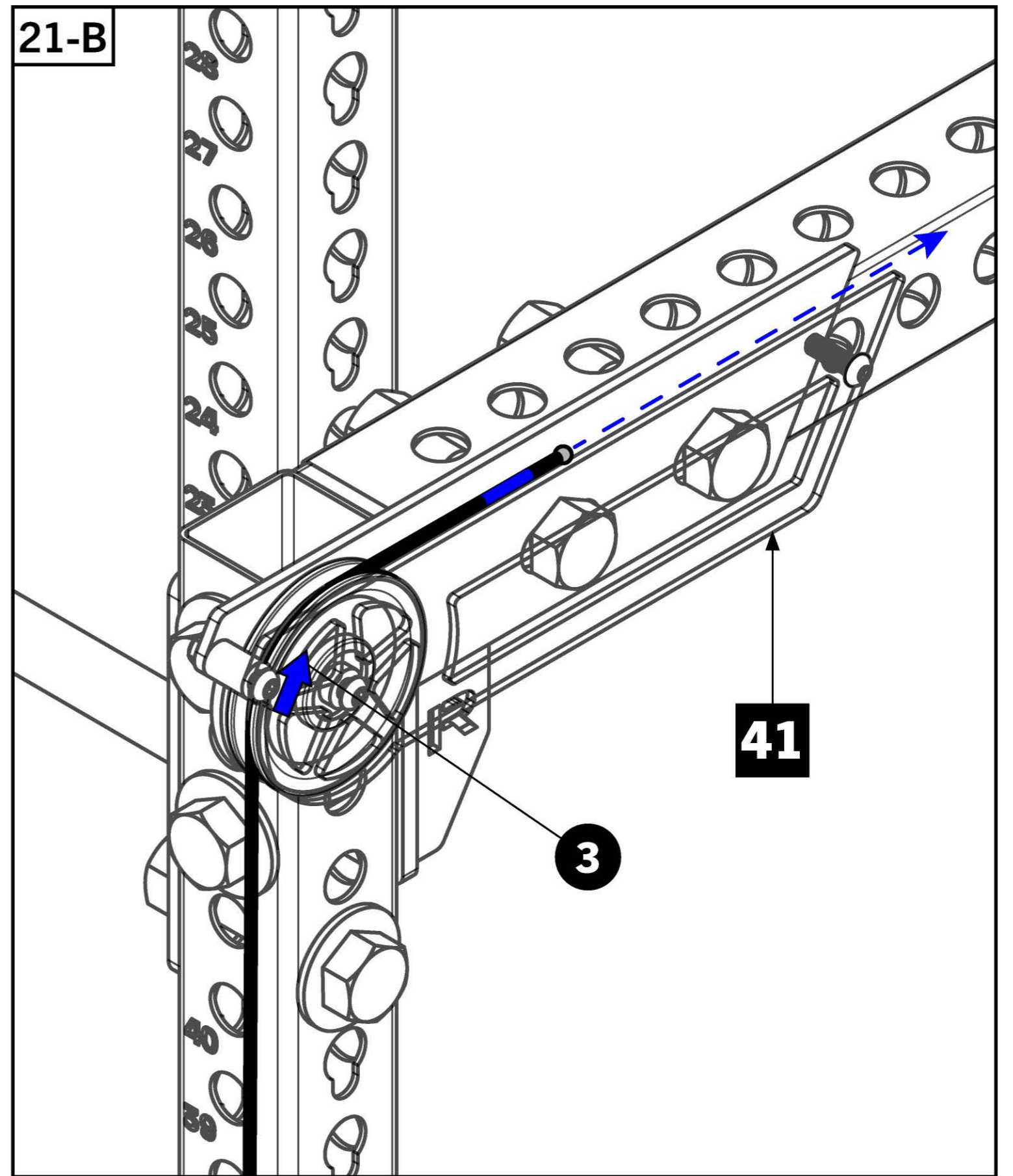
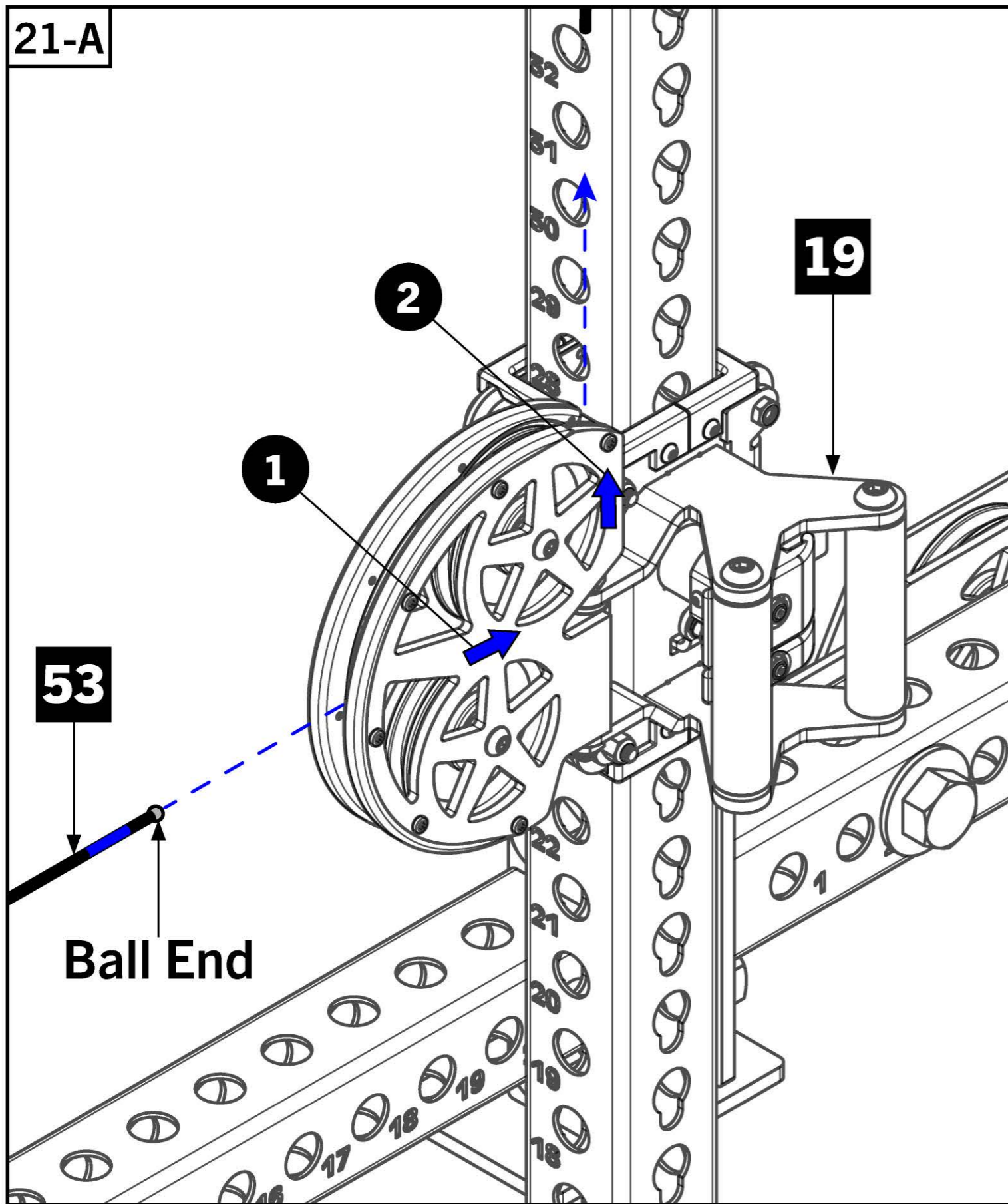
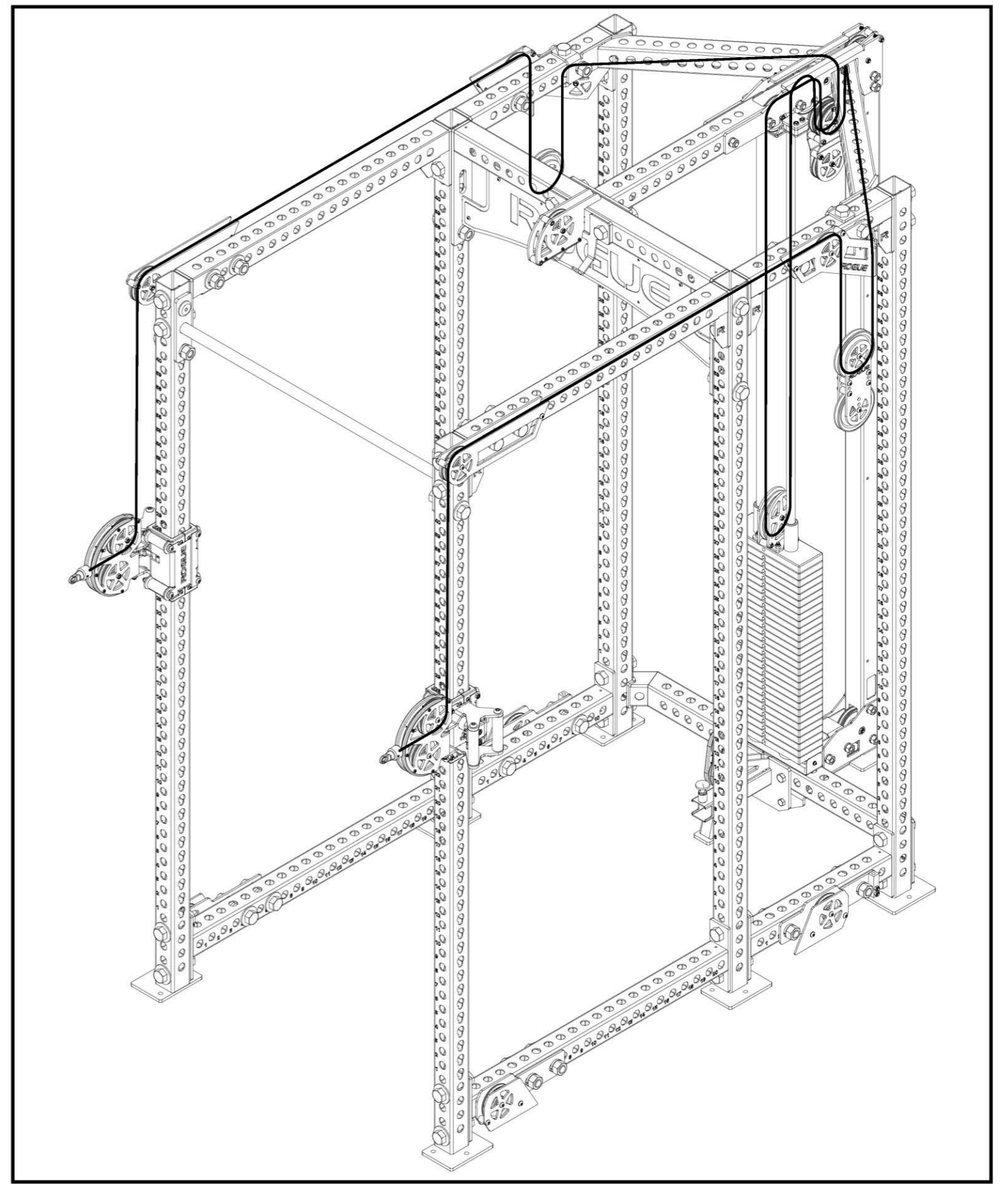

## STEP 22

- Hold one Side Peanut Pulley [50] in the air, ensuring the arrow stickers correspond to diagram 22-A.
- Feed the cable down and around the upper pulley of Side Peanut Pulley and then back up towards the Top Rear Side Pulley Assembly - RH [43].
- Feed cable around the angled pulley shown in 22-B and continue towards the Rear 3X3 Upright.

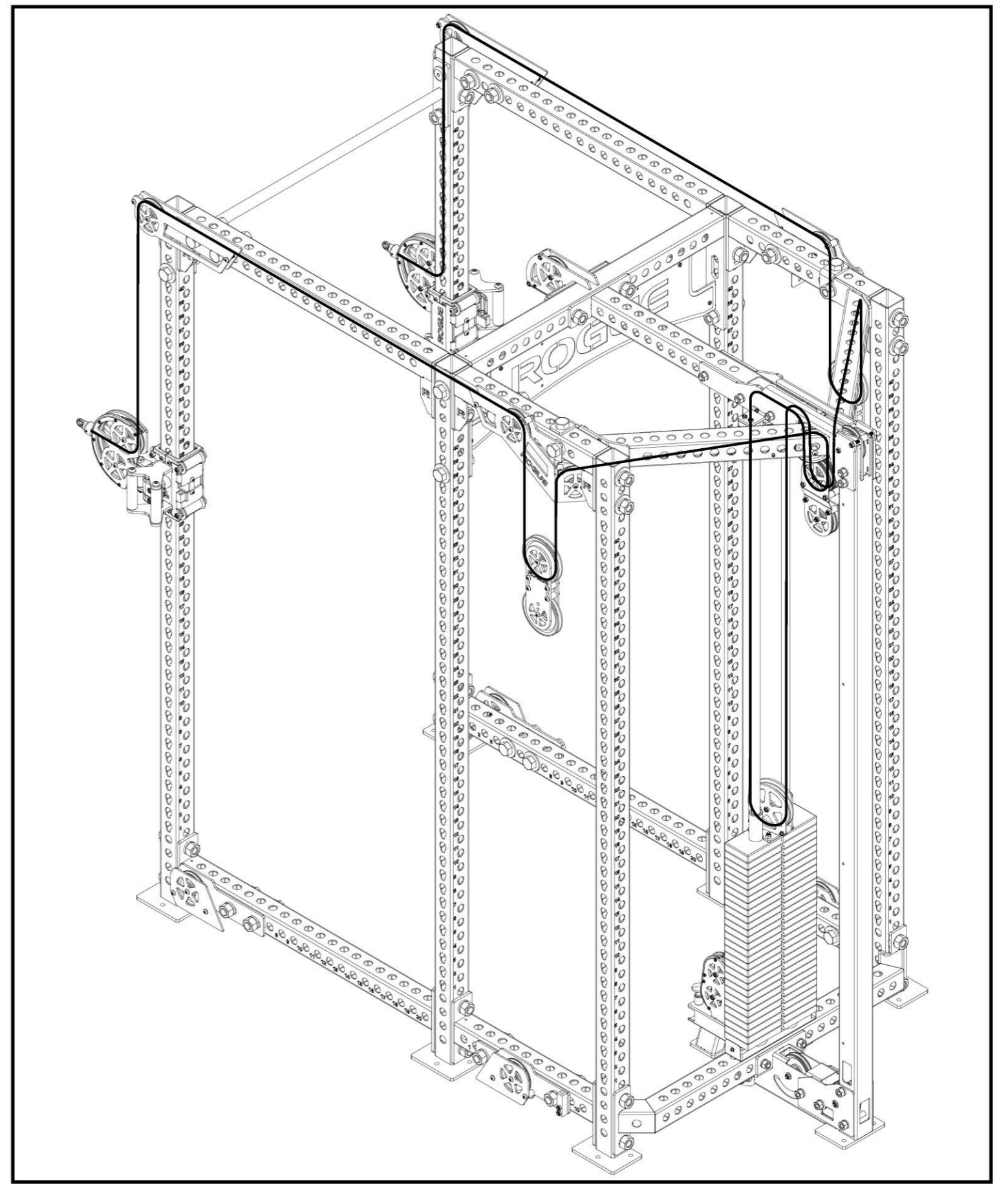

22-A

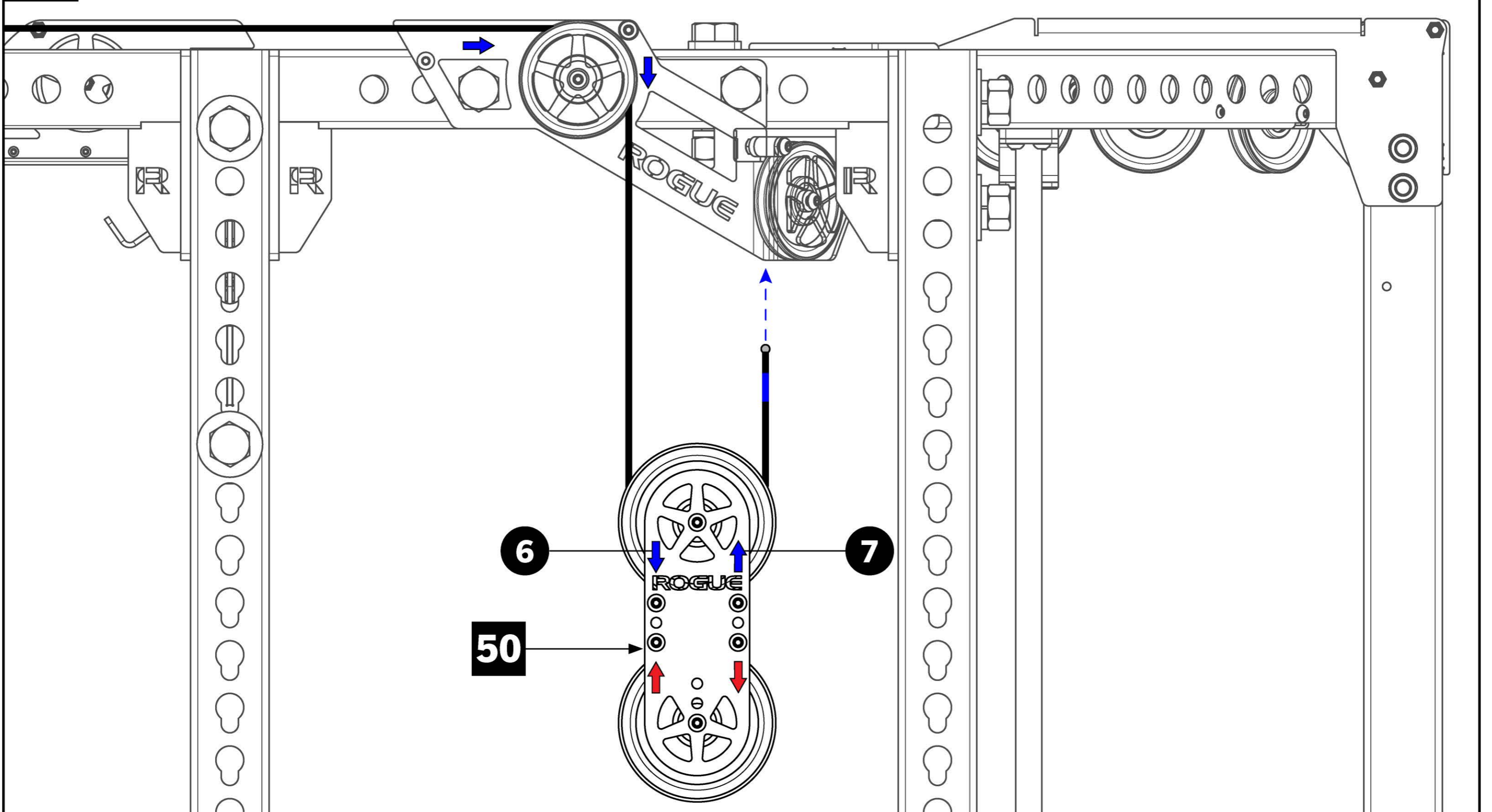

22-B

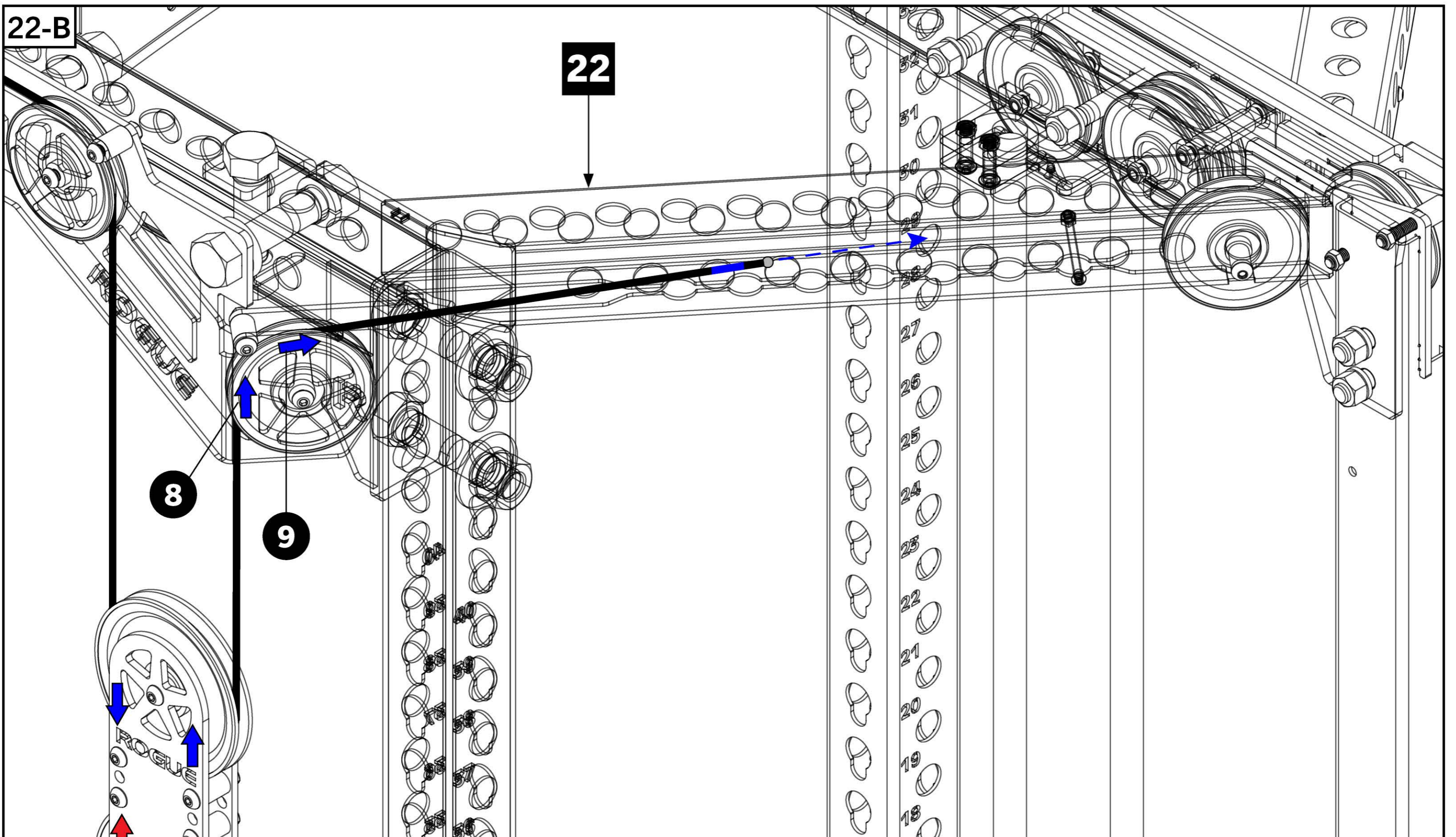

## STEP 23

- Feed cable around the next angled pulley at rear of the Top Rear Angle Crossmember - RH [22] as shown.
- Hold the Rear Peanut Pulley [49] underneath cable, ensuring the arrow stickers correspond to diagram 23-B.
- Feed cable around the upper RH offset pulley in the Peanut, and then back up and around the next two pulleys shown in 23-C.

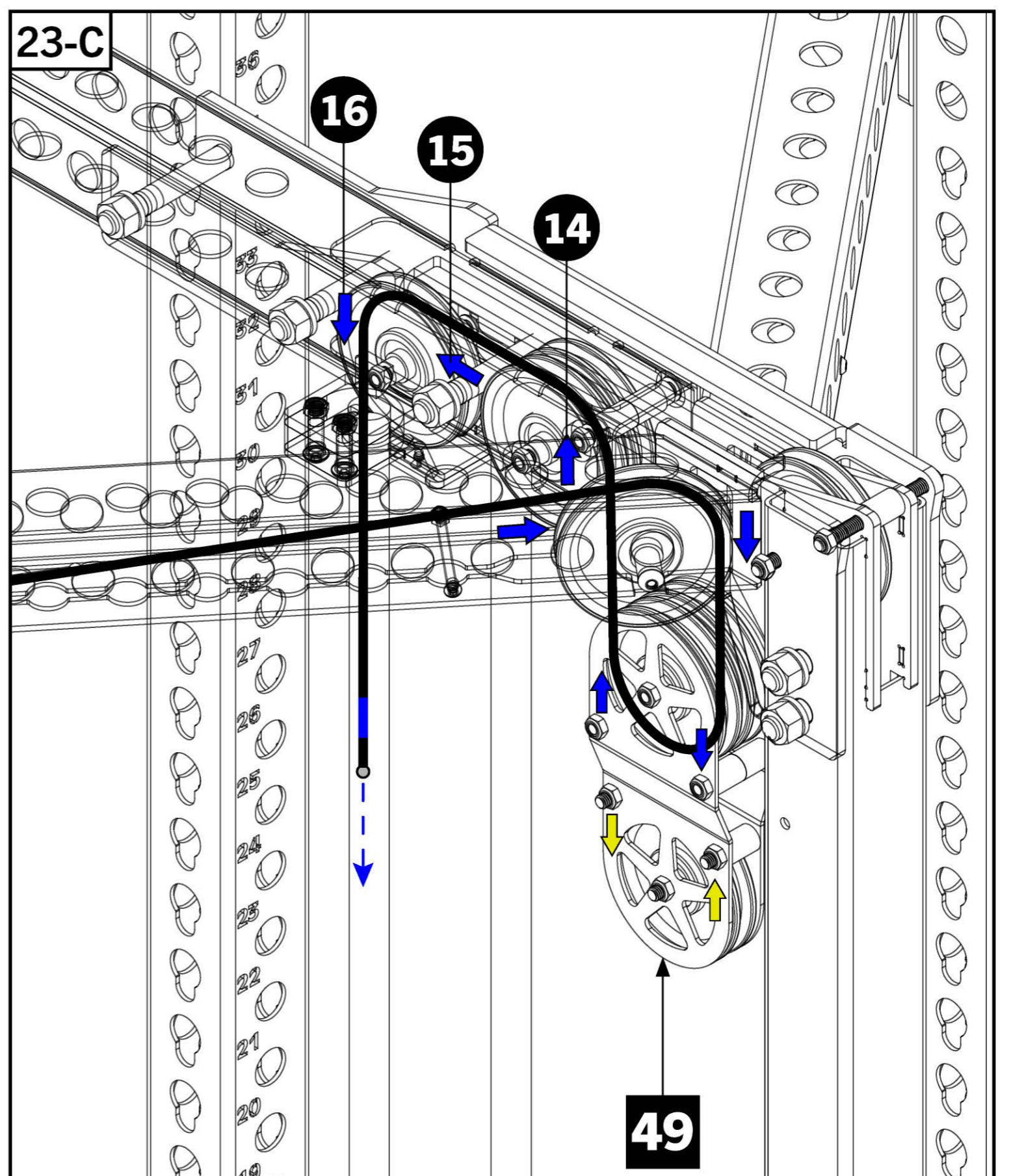
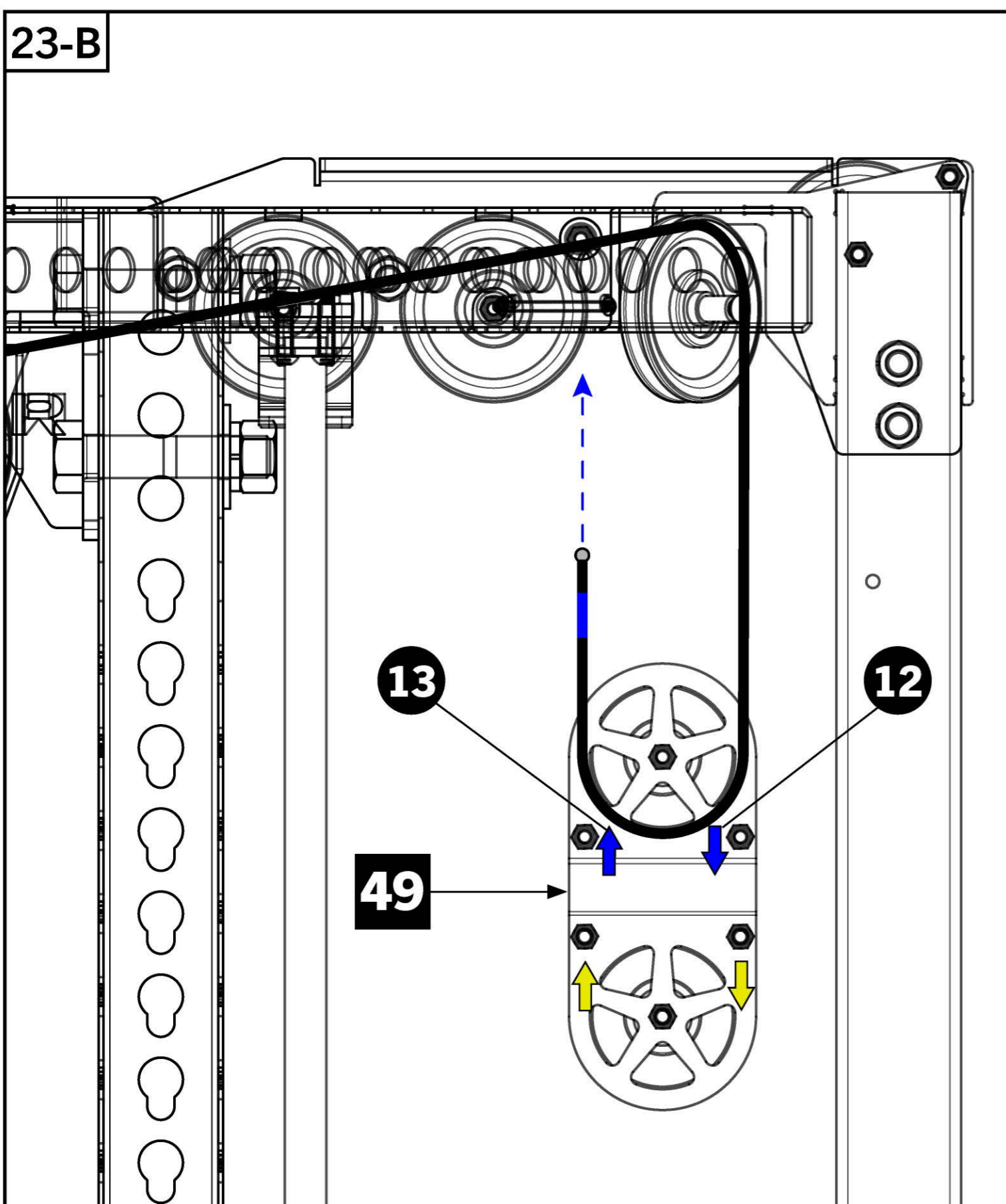
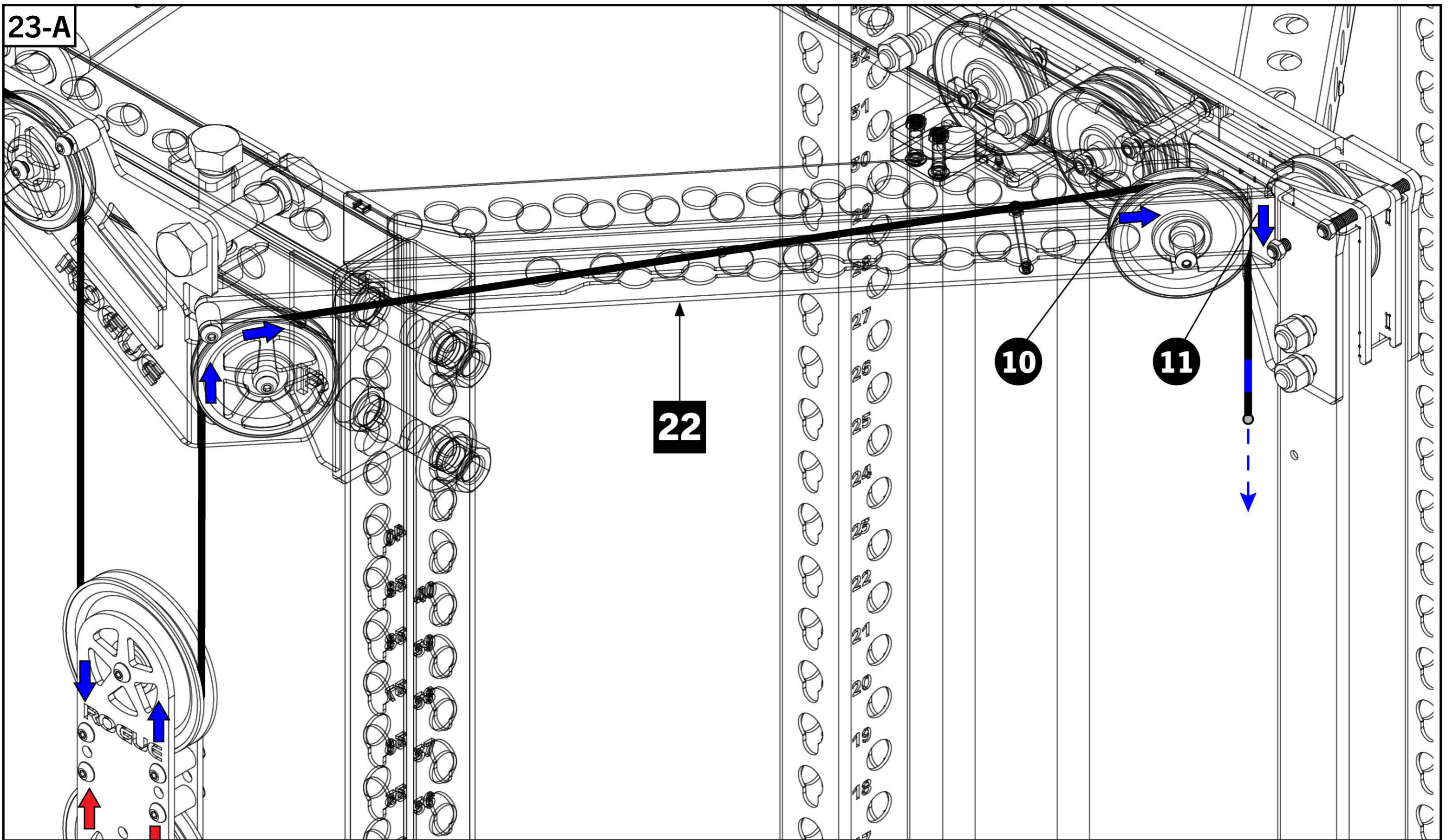
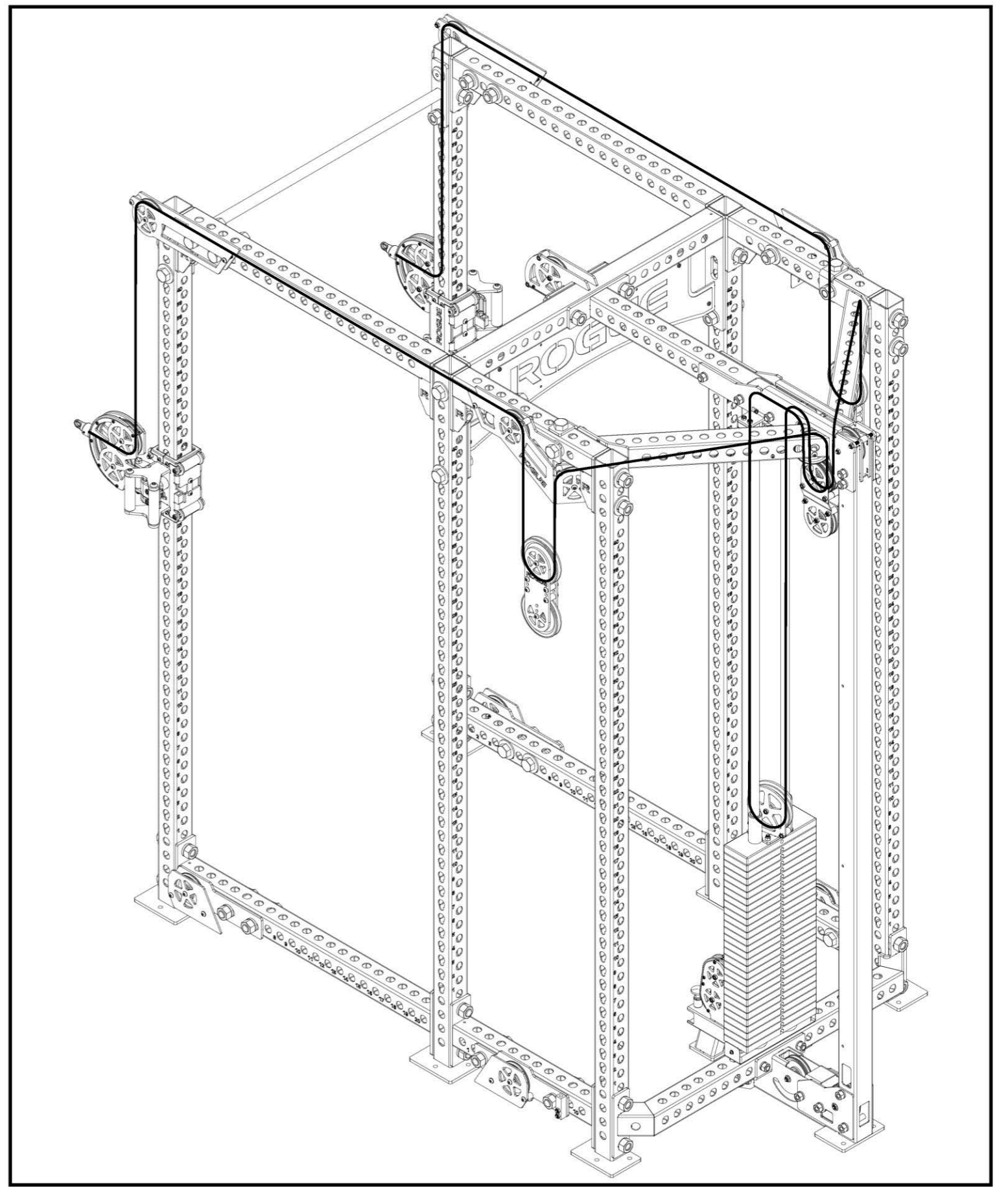

## STEP 24

- Continuing down towards the Weight Stack, feed cable around the large 6.5" Pulley located on top of the Weight Stack Stem. **Tip:** a flathead screwdriver may be used to help guide cable through turn 18.
- Feed cable back up to the Top Center Crossmember, feeding around the pulley shown in **24-B** and then immediately back down towards the Rear Peanut Pulley [49].
- Continue around the other Top Pulley on the peanut and then back up and around the pulley shown in the Rear Angled Crossmember - LH [23].
- Continue around the next angled pulley located in the Top Rear Side Pulley Assembly - LH [44] and then downward.

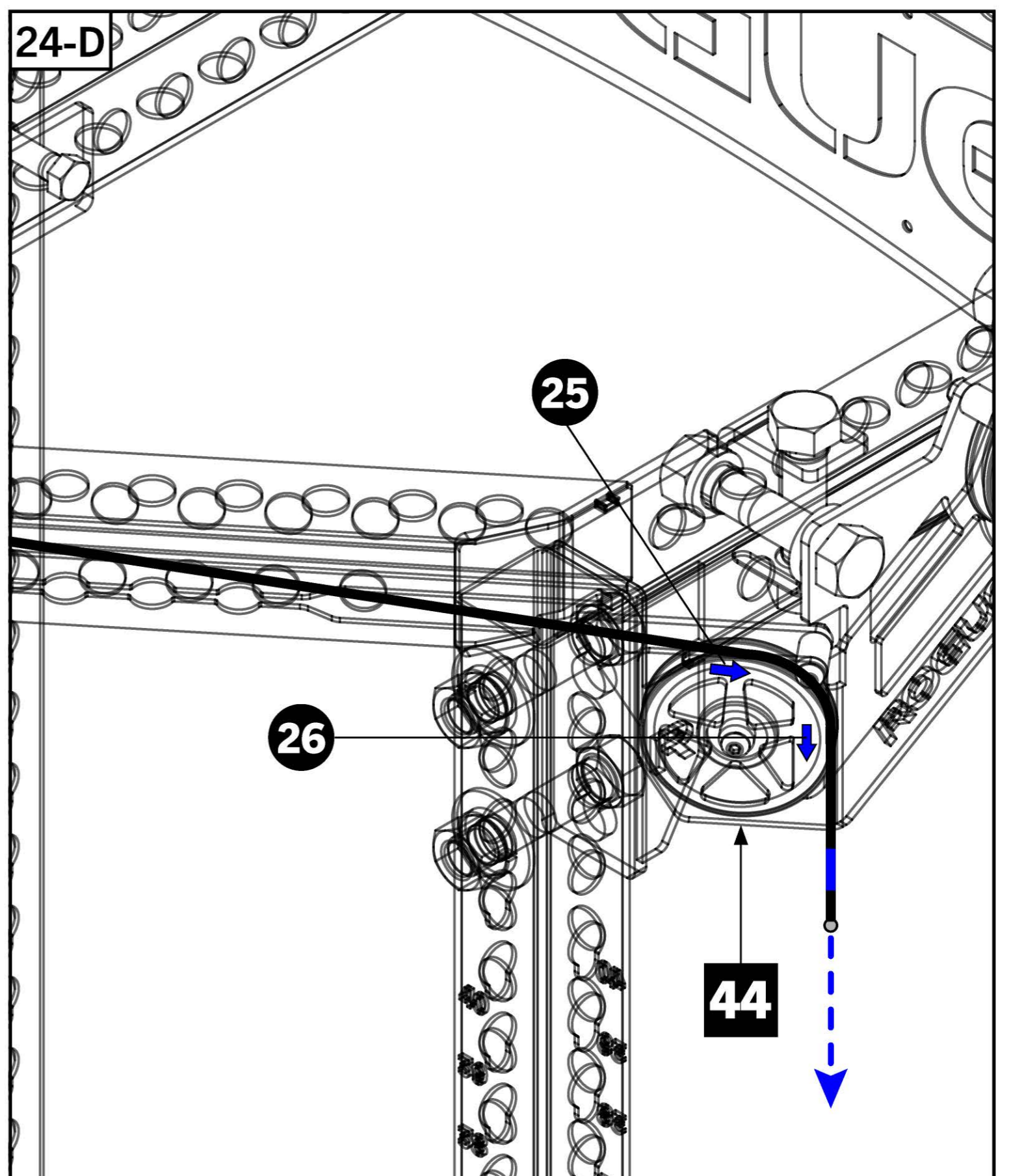
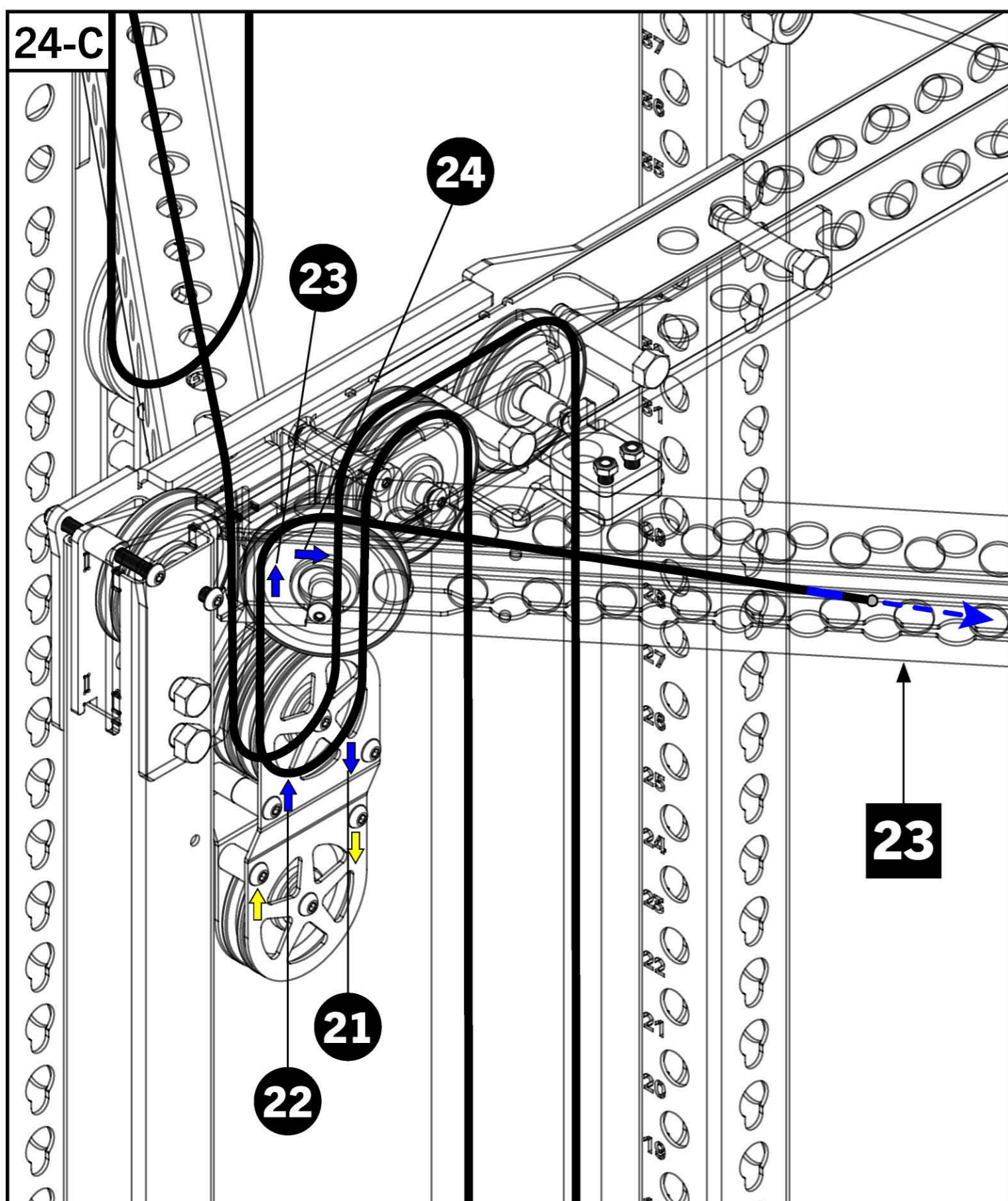
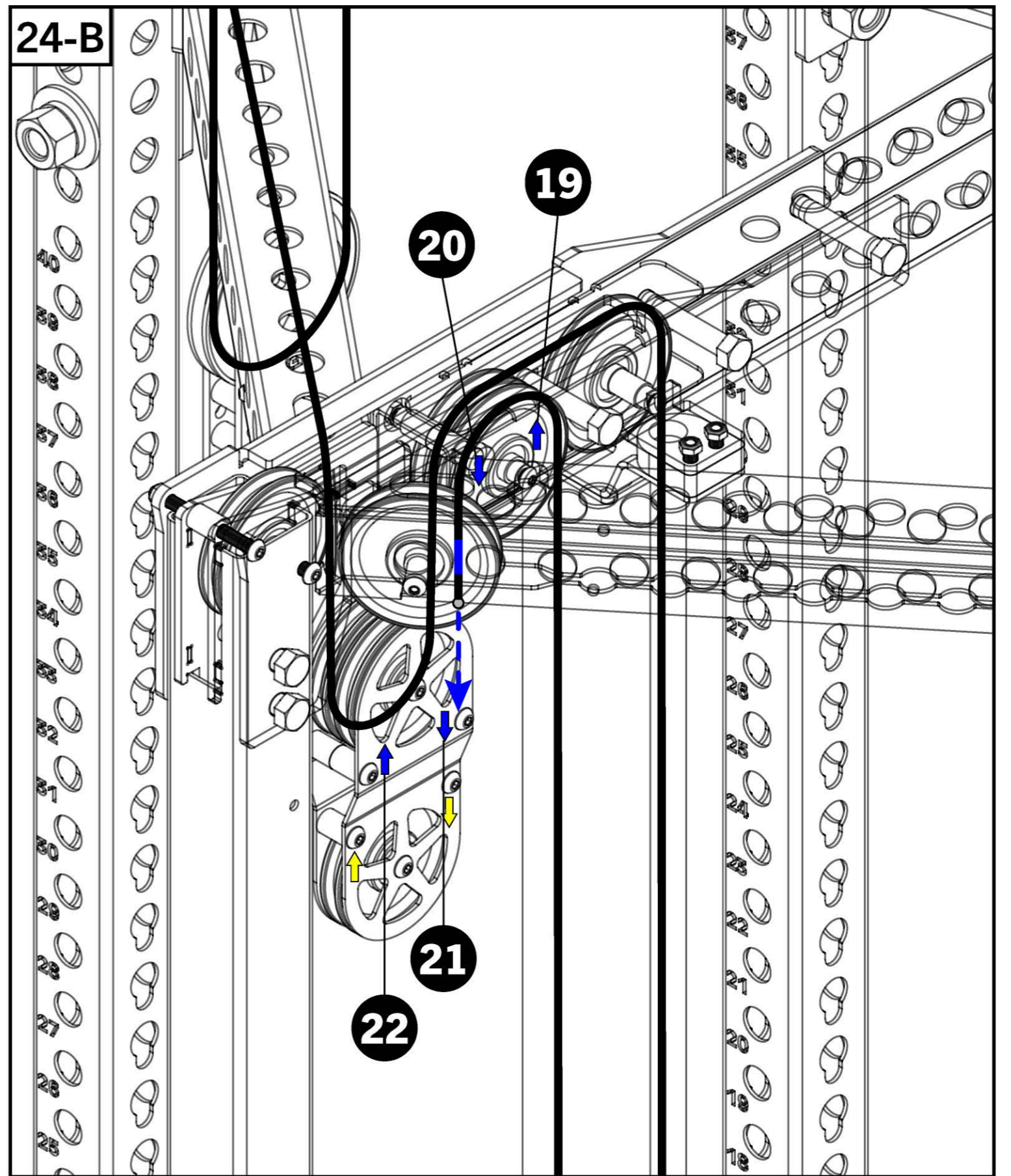
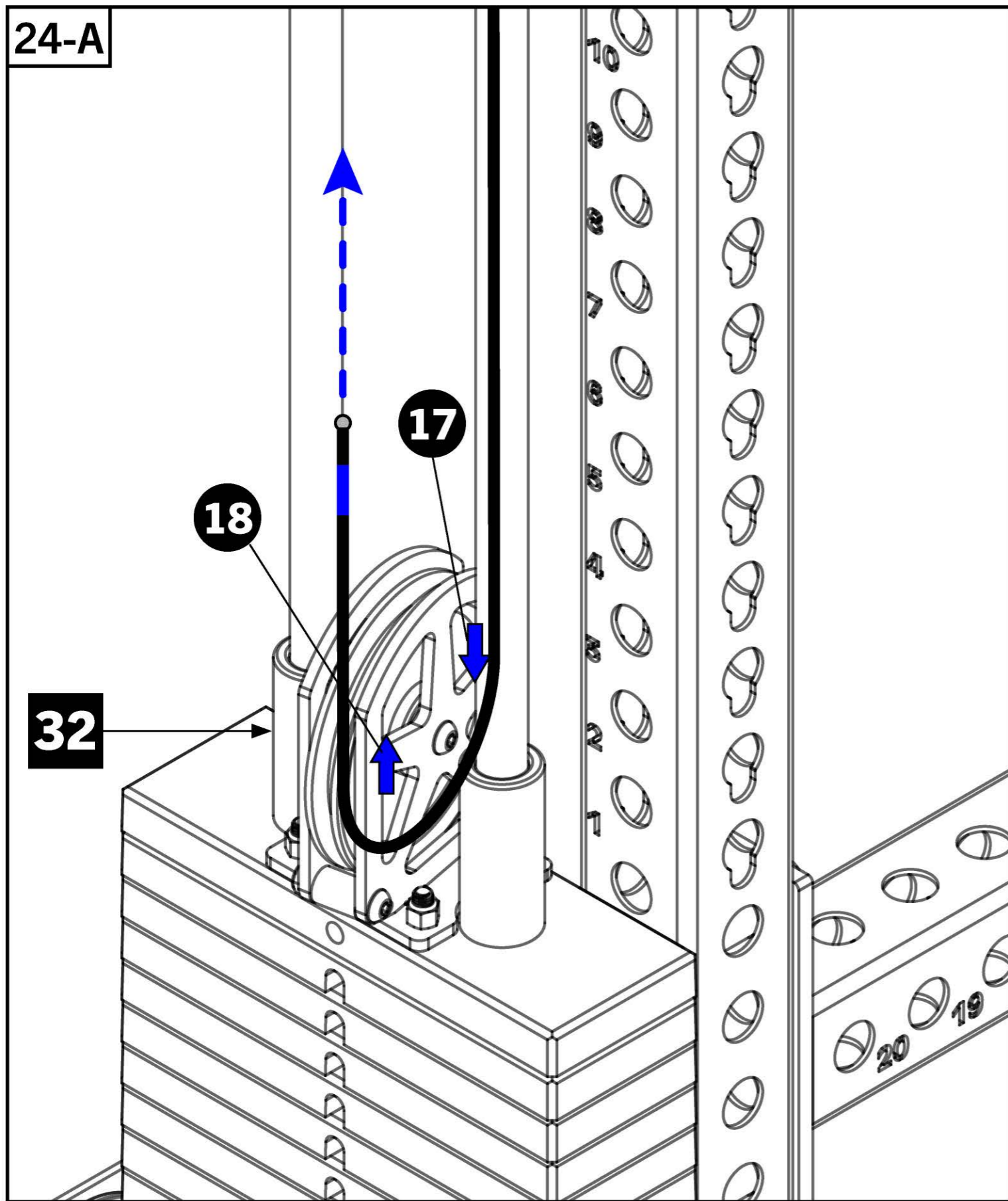
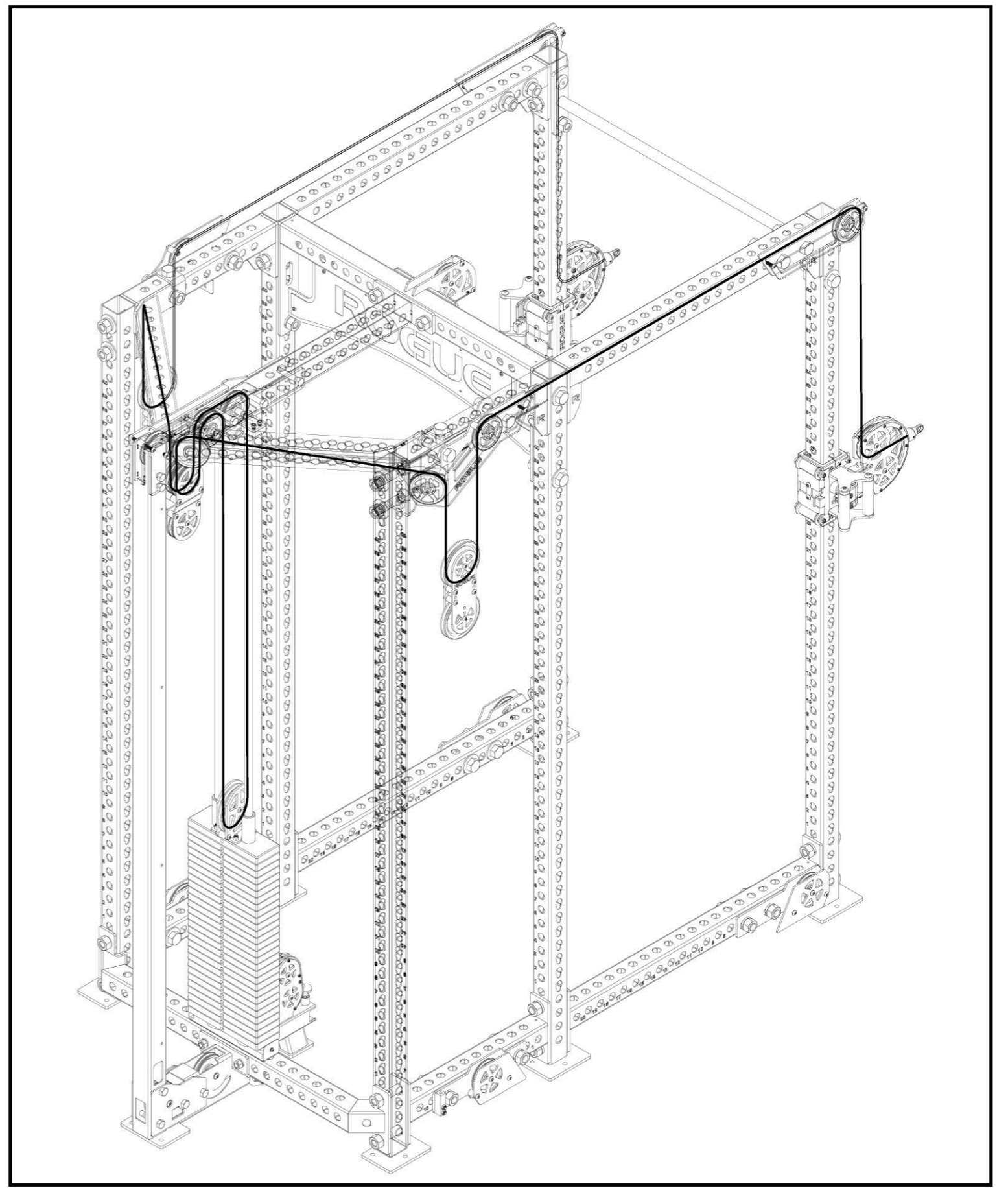

## STEP 25

- Hold the remaining Side Peanut Pulley [50] in the air, ensuring the arrows correspond to diagram 25-A.
- Feed cable around the upper peanut pulley and then back up towards the Rear Side Pulley Assembly.
- Feed around the pulley shown in 25-B and then towards the front of the rack.
- Continue around the Top Front Side Pulley Assembly - LH [22], then down and out through the front of the Swivel Trolley LH [20].
- Pull Ball End of cable out far enough to assemble Clevis on next step.

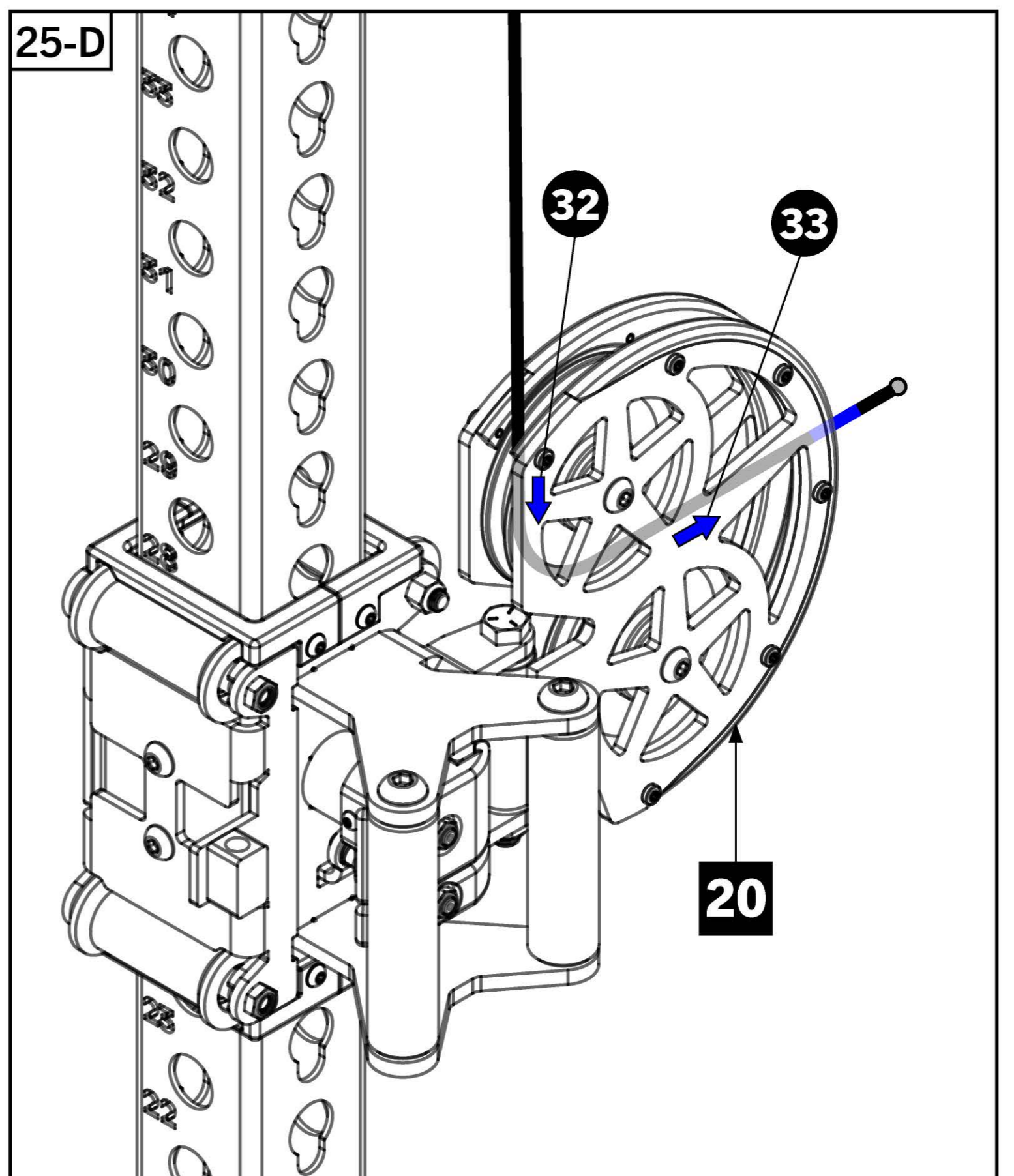
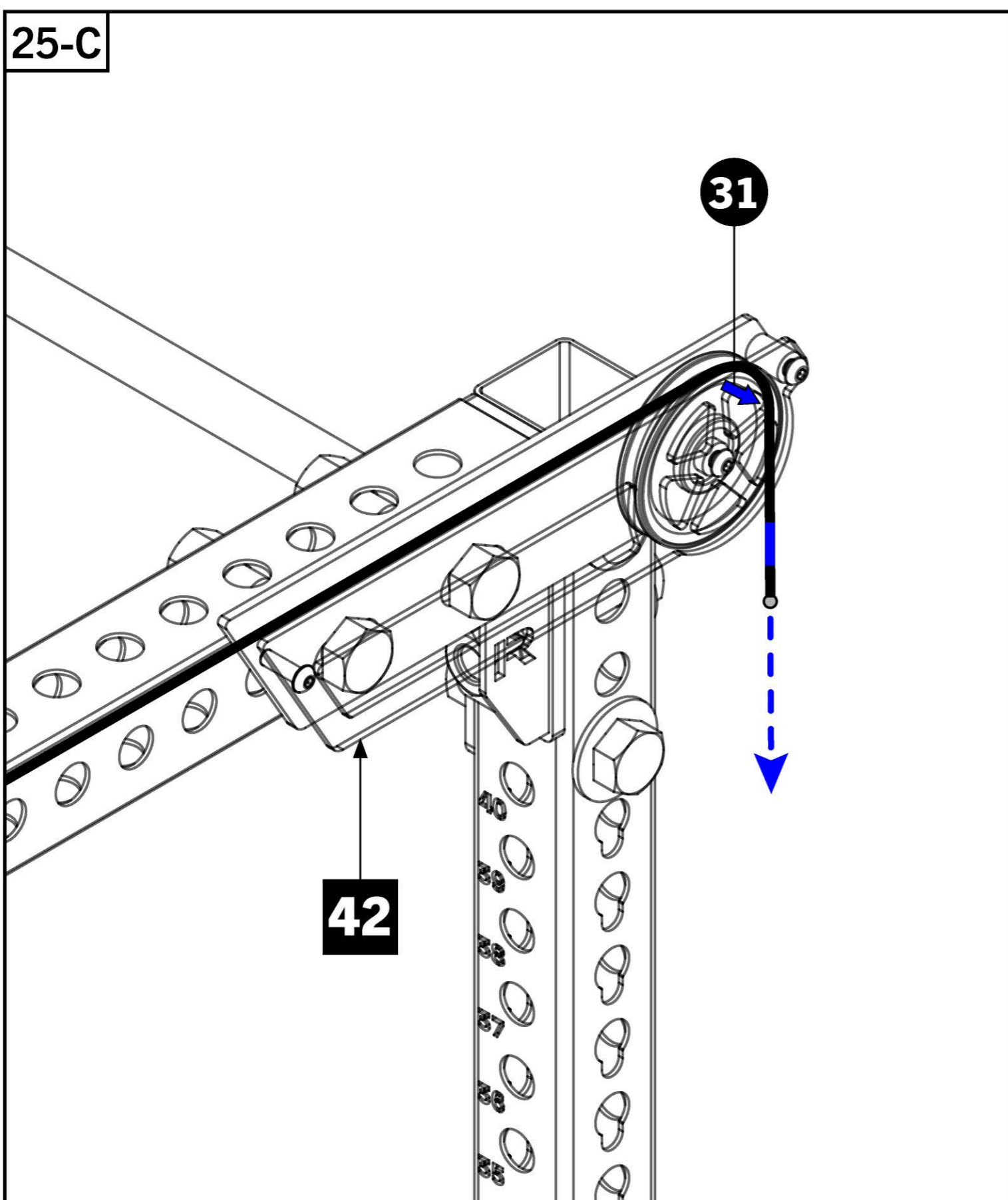
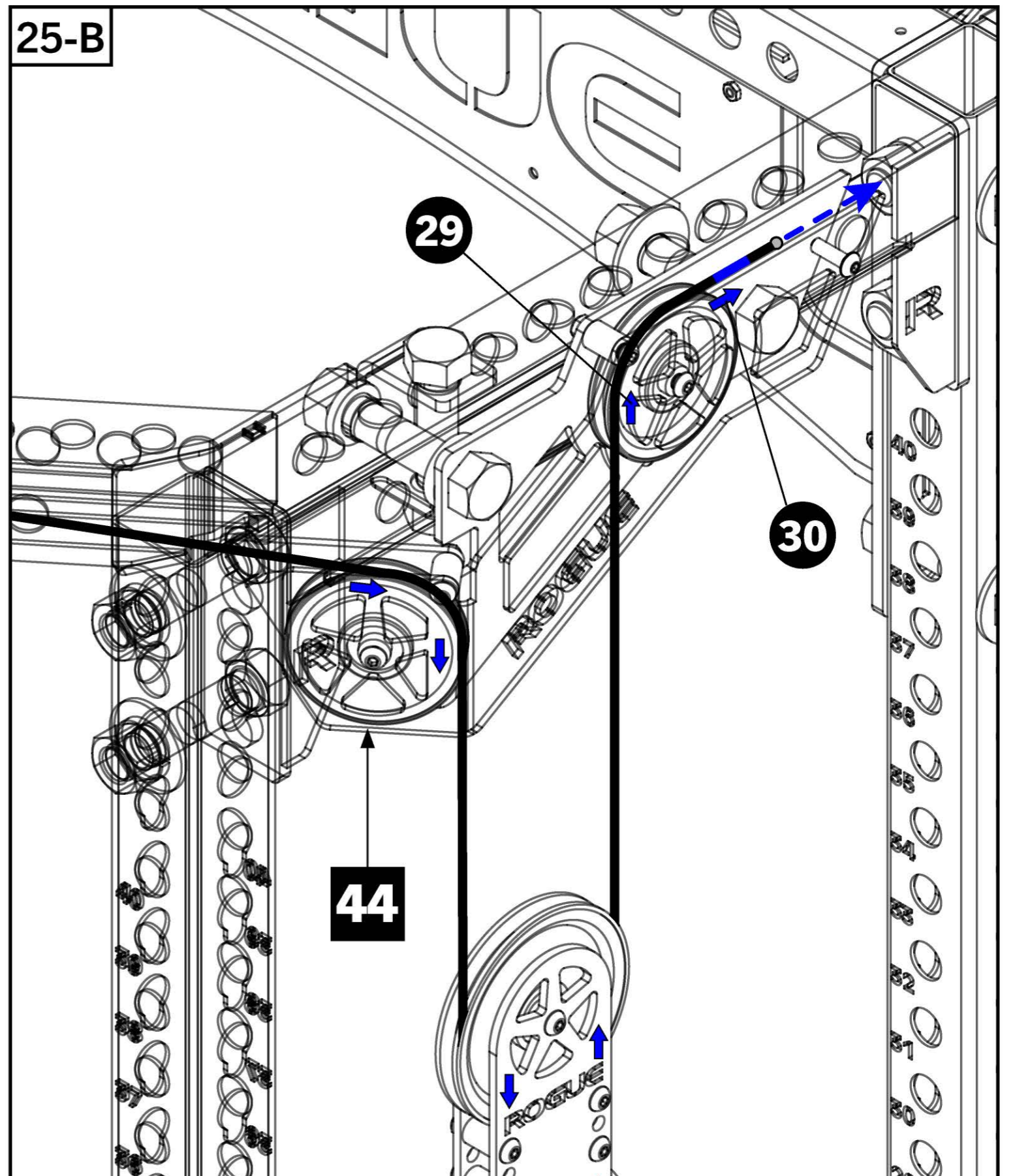
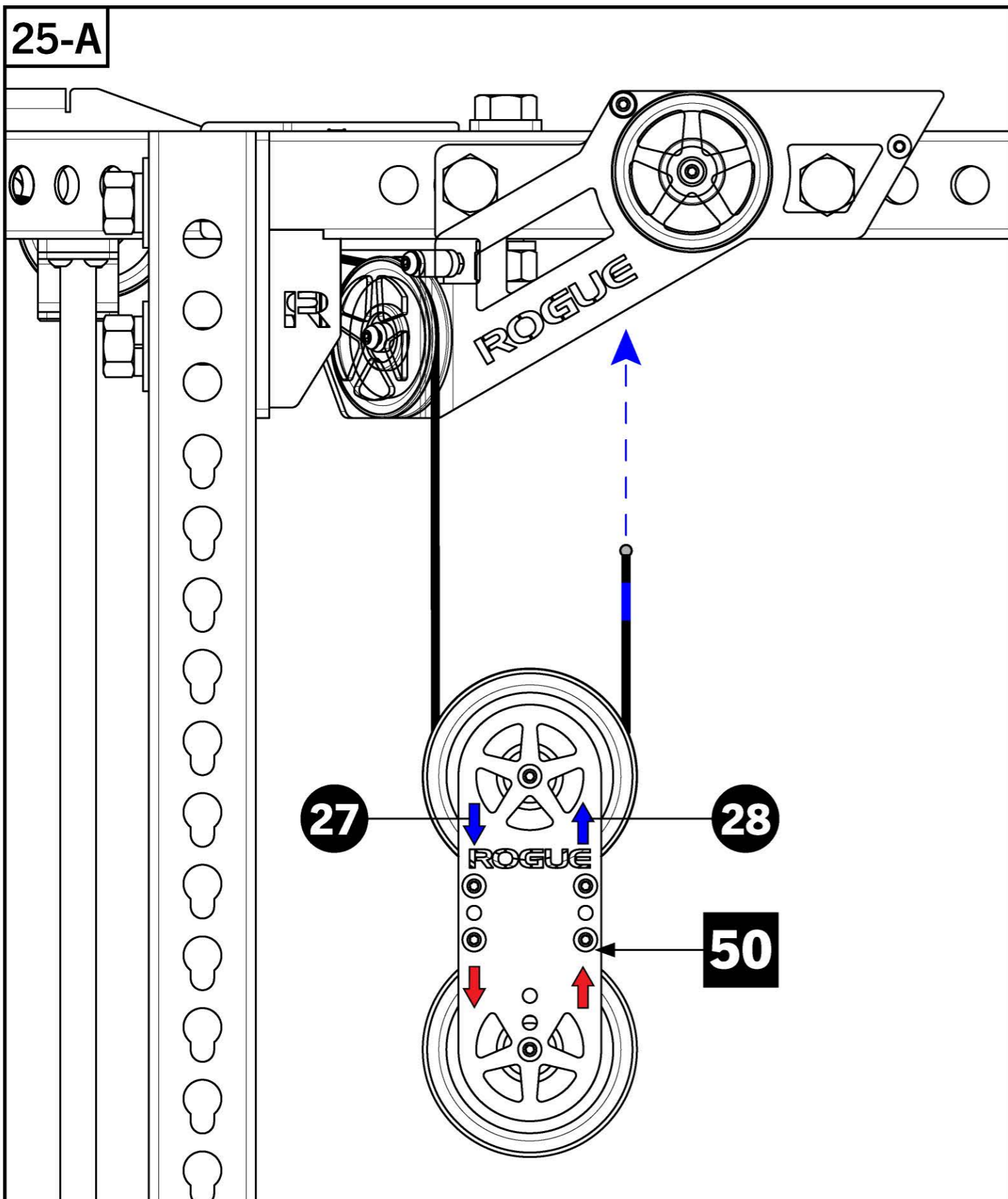
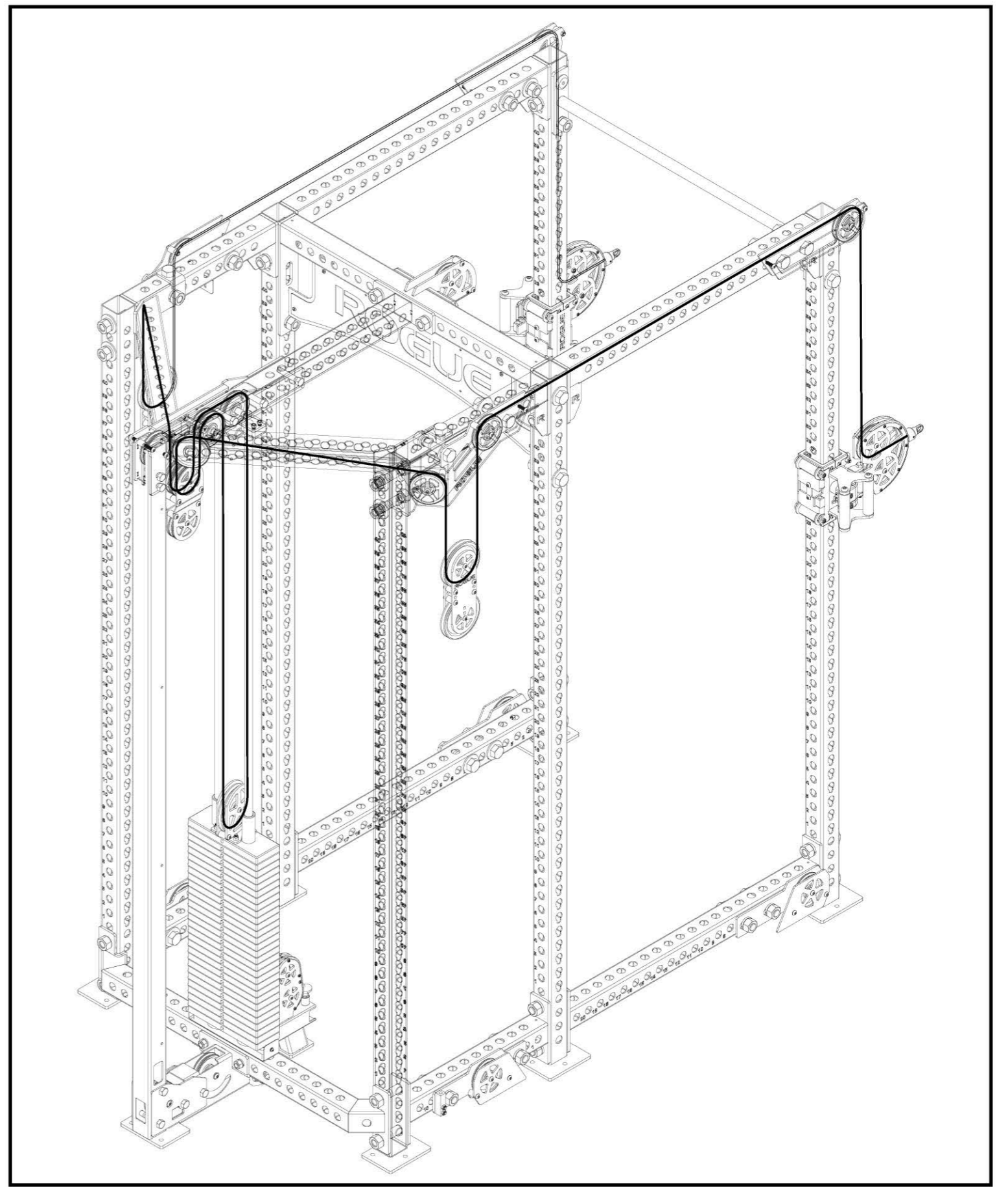

## STEP 26

### Tools Required:

- 3/32" Allen Key & 5/8" Wrench
- Completely disassemble the loose Clevis included with cable by unscrewing set screws and Split Threaded Insert, and remove blue tag on end of cable.
- Slide parts over the ball on cable as shown on **26-B**.

- Insert Grommet into non-threaded side of Split Threaded Insert and screw Clevis End on threaded side using 5/8" Wrench.
- Slide Plastic Stop forward and align outer holes with threaded holes on Clevis End and re-insert Set Screws. Fully tighten Set Screws.

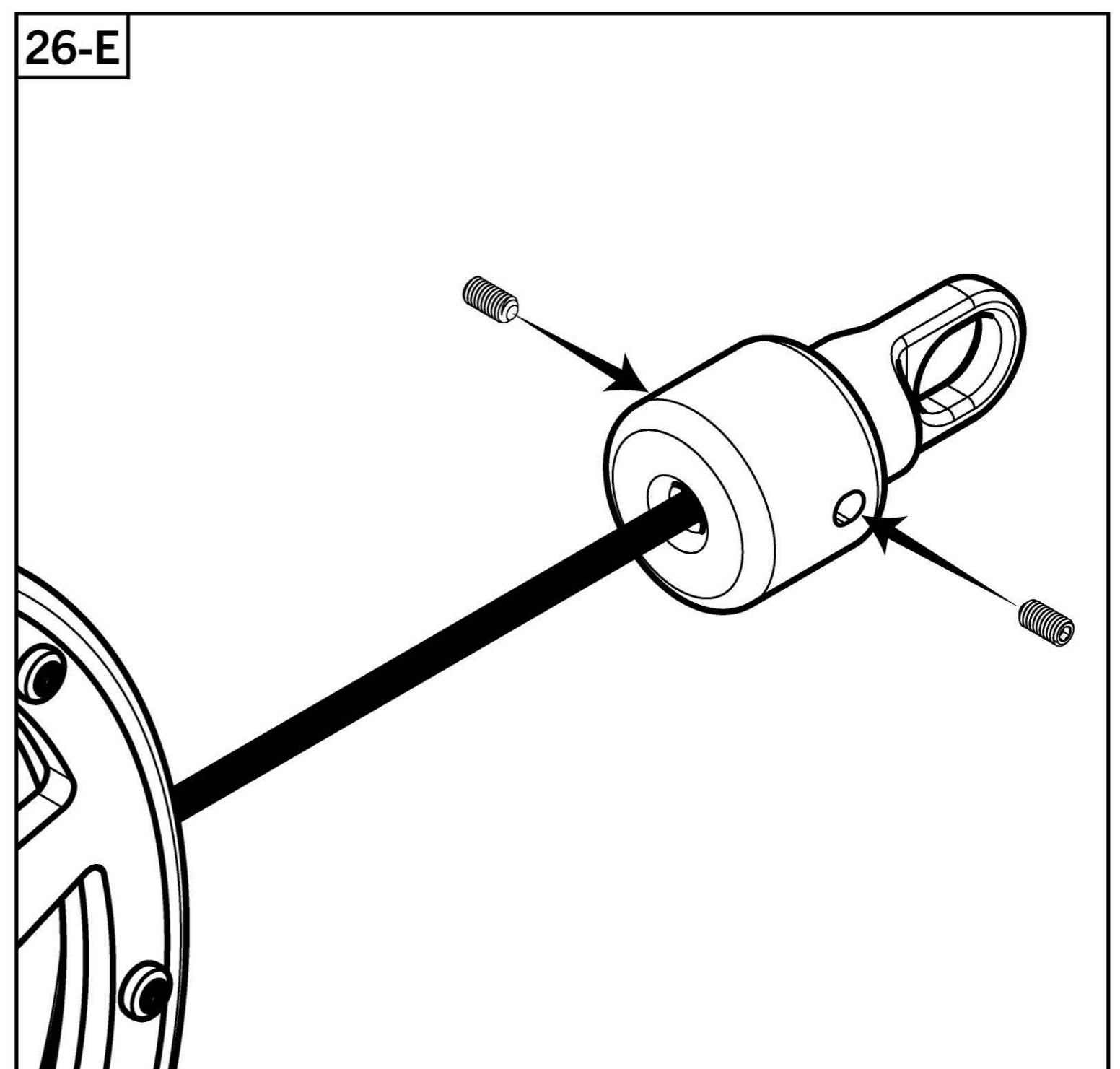
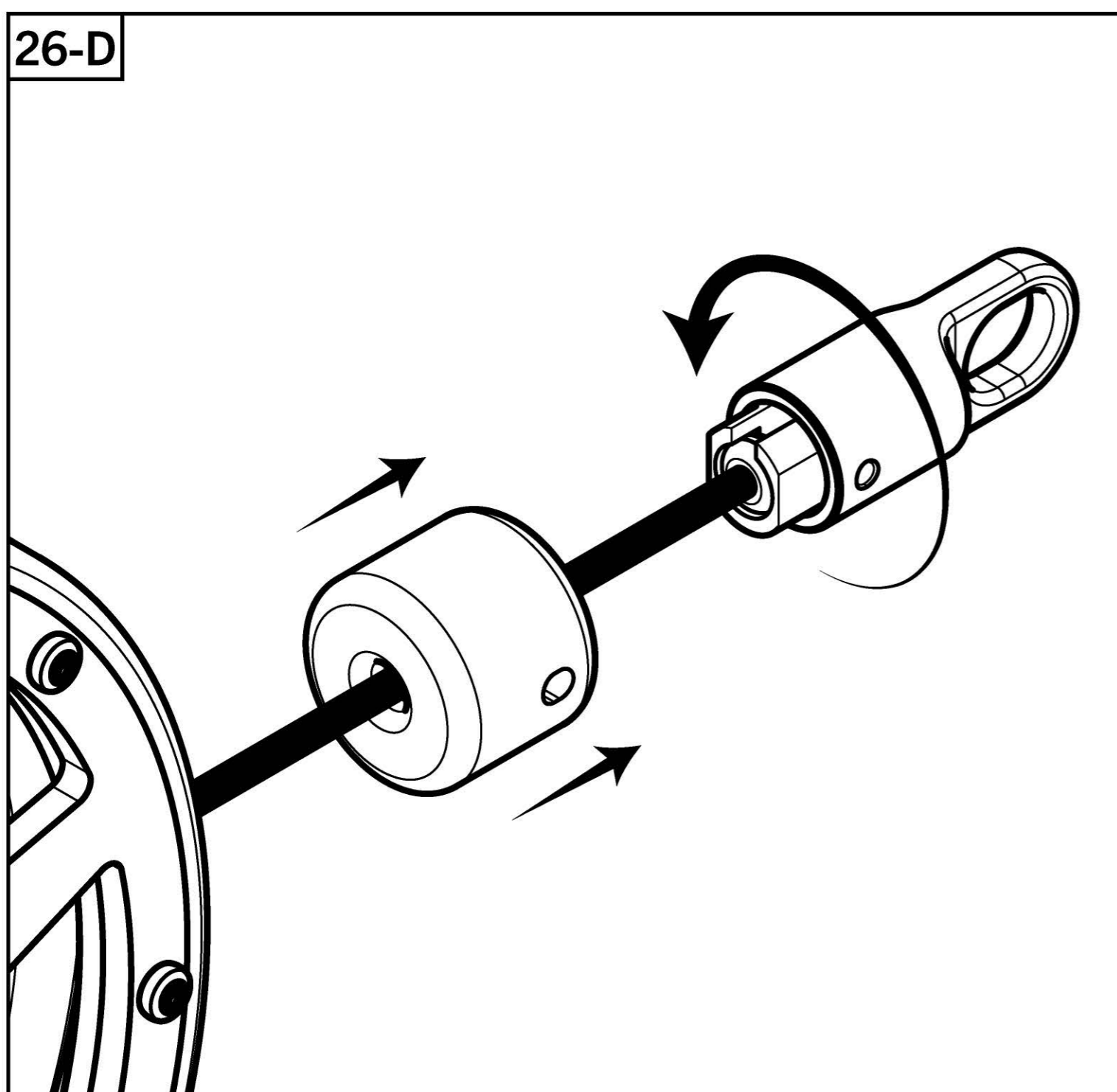
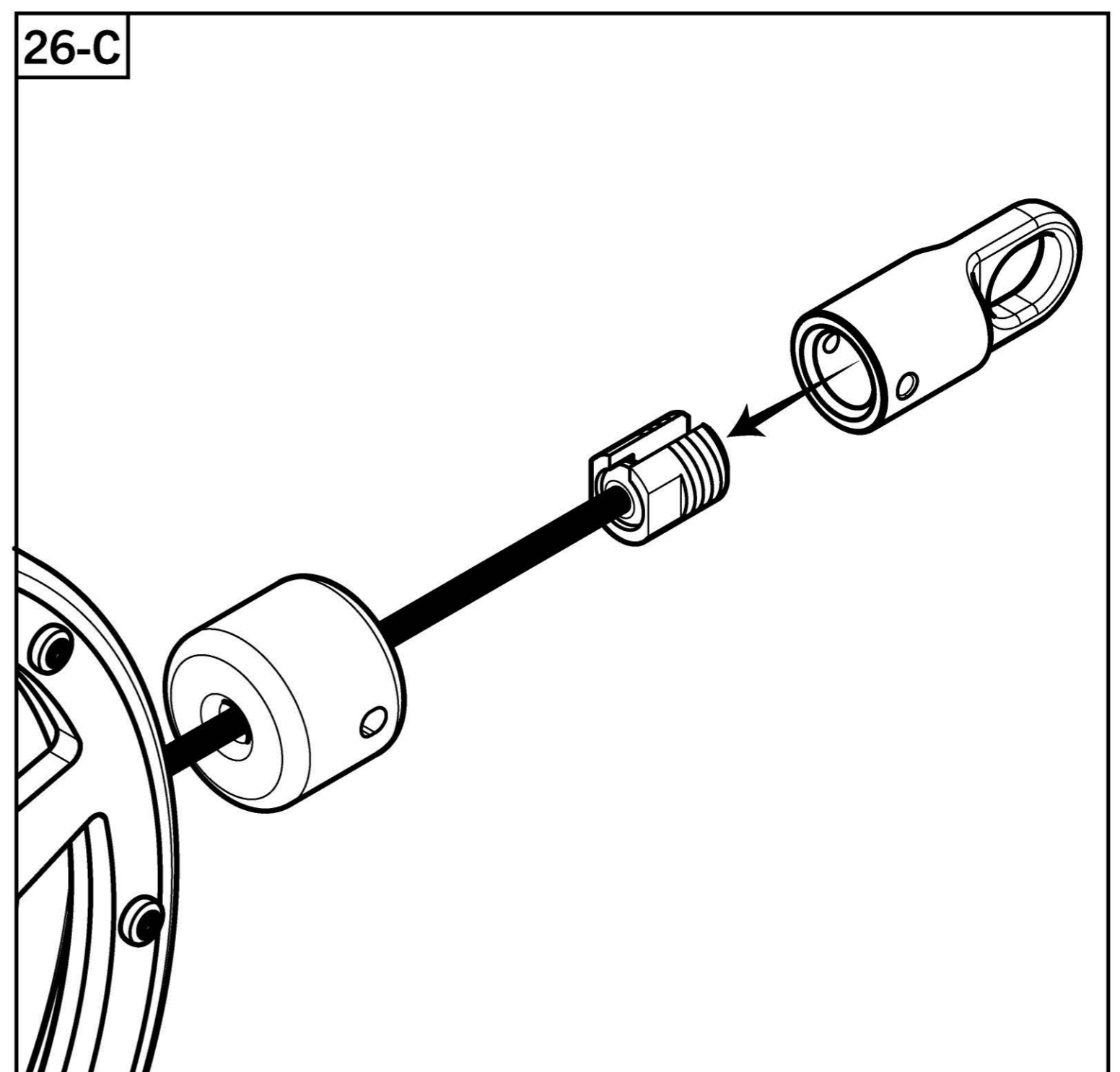
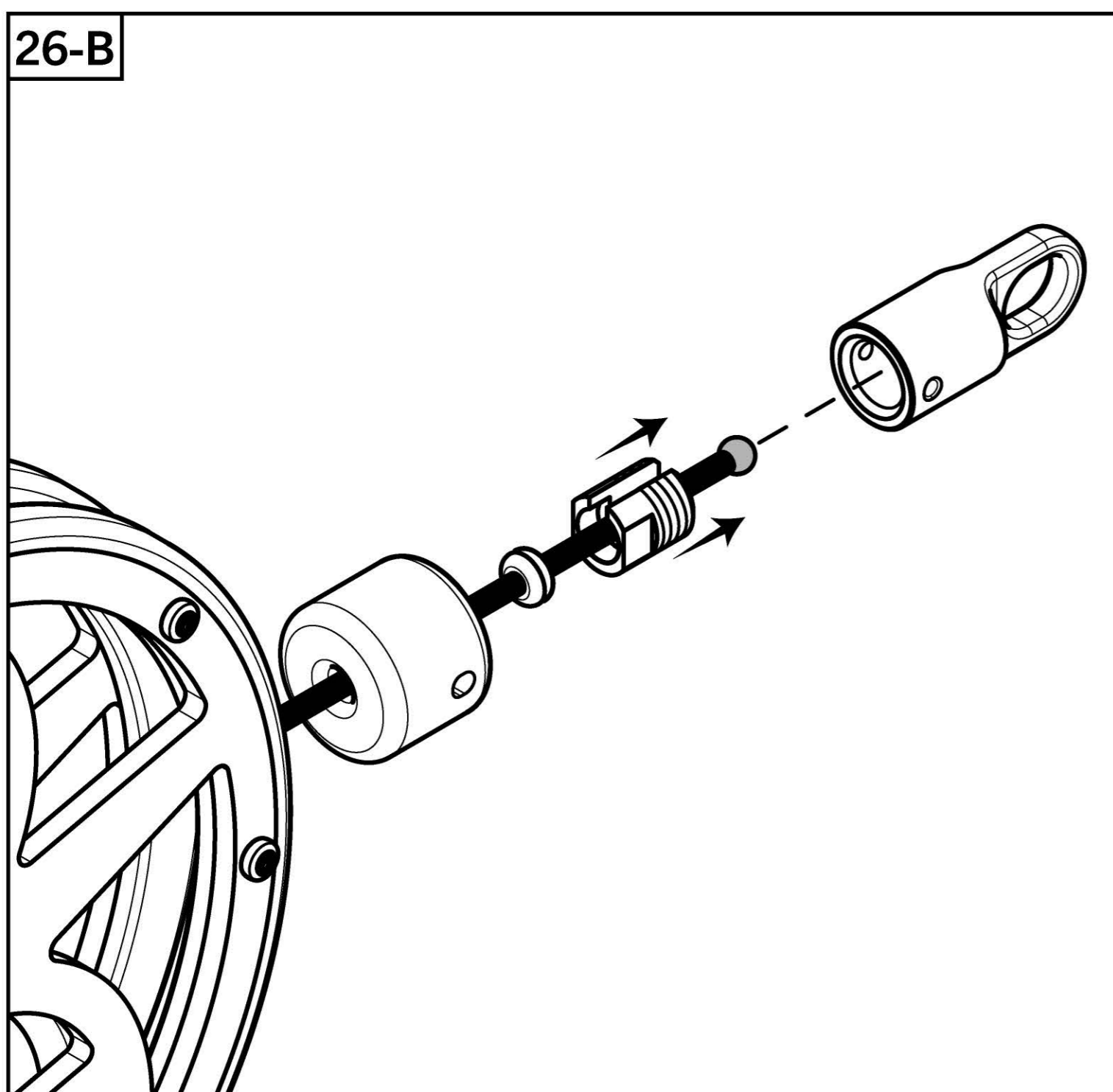
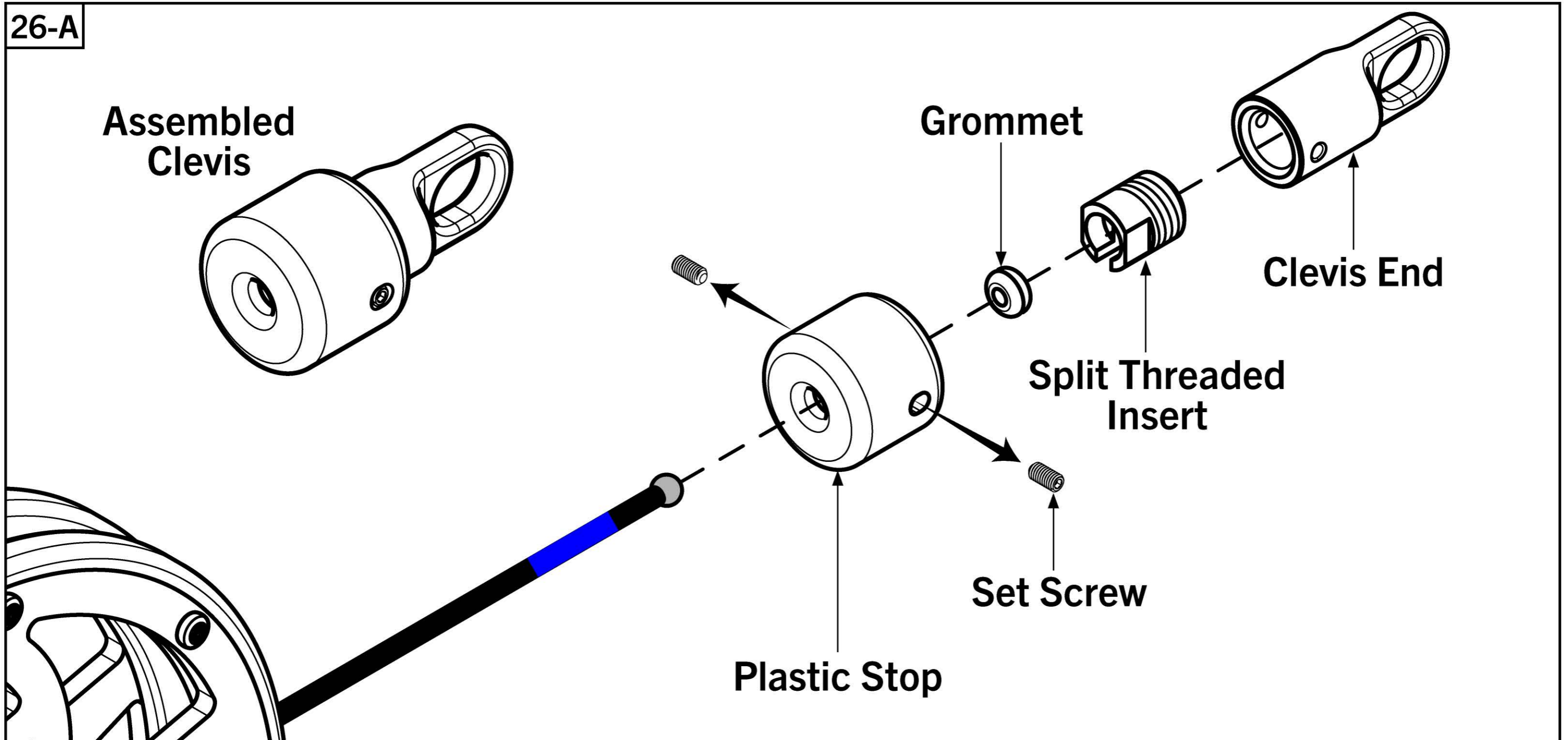



# STEP 27

## Note:

- Completely unwind and straighten out Lat Pull Cable [54] to remove any twists/kinks prior to installation.
- Next assemble the Lat Pull/Low Row cable indicated by the yellow indicator on Ball End of cable and corresponding yellow arrows shown in **STEPS 27-29**
- Feed the Ball End of Lat Pull Cable [54] up and over the pulley in Lat Pulldown Pulley Bracket [26] and then towards the back of the rack.
- Feed around the pulley in the top of Rear 3X3 Upright [17] and then all the way down, ensuring cable runs **INSIDE THE UPRIGHT**.

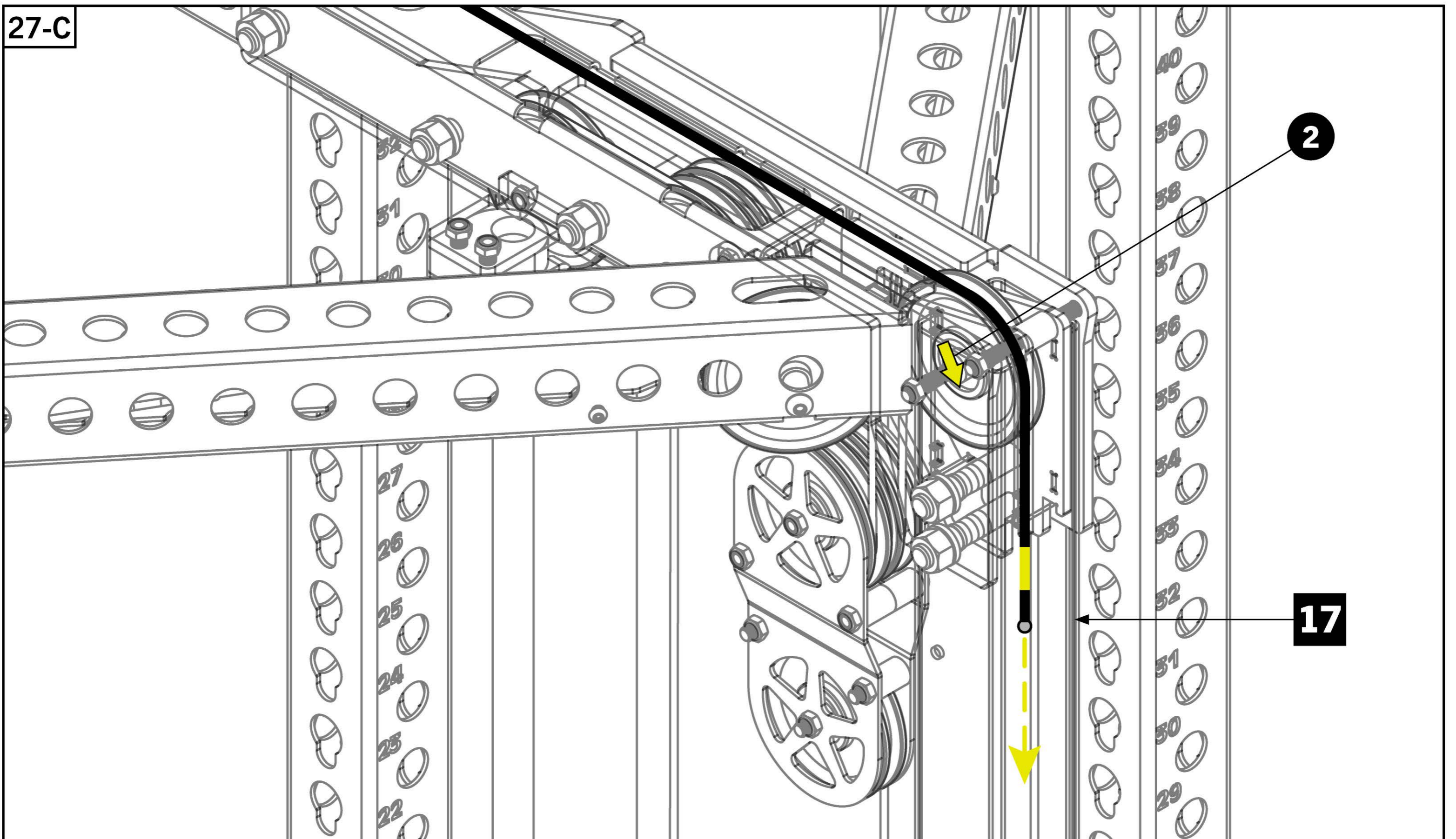
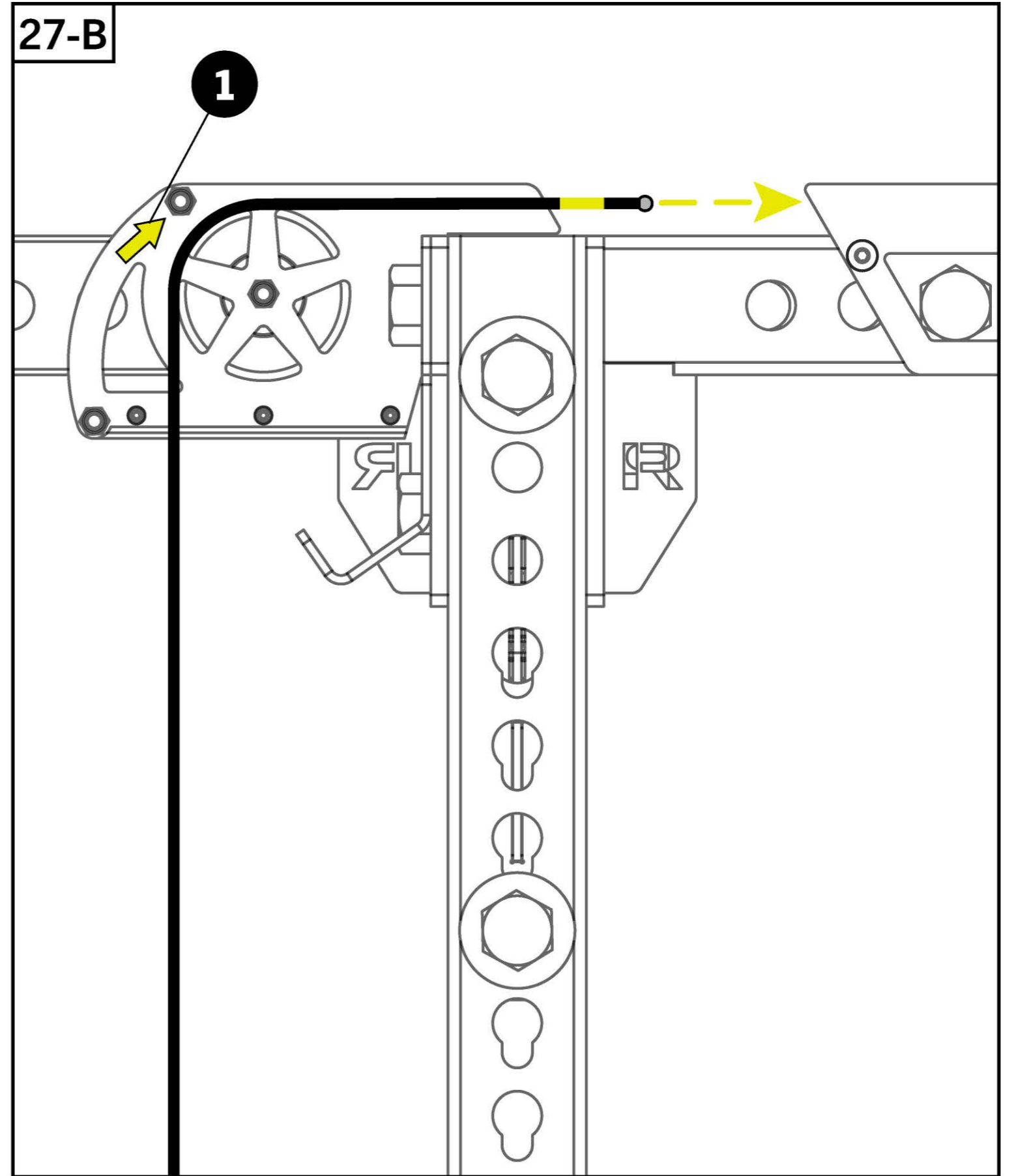
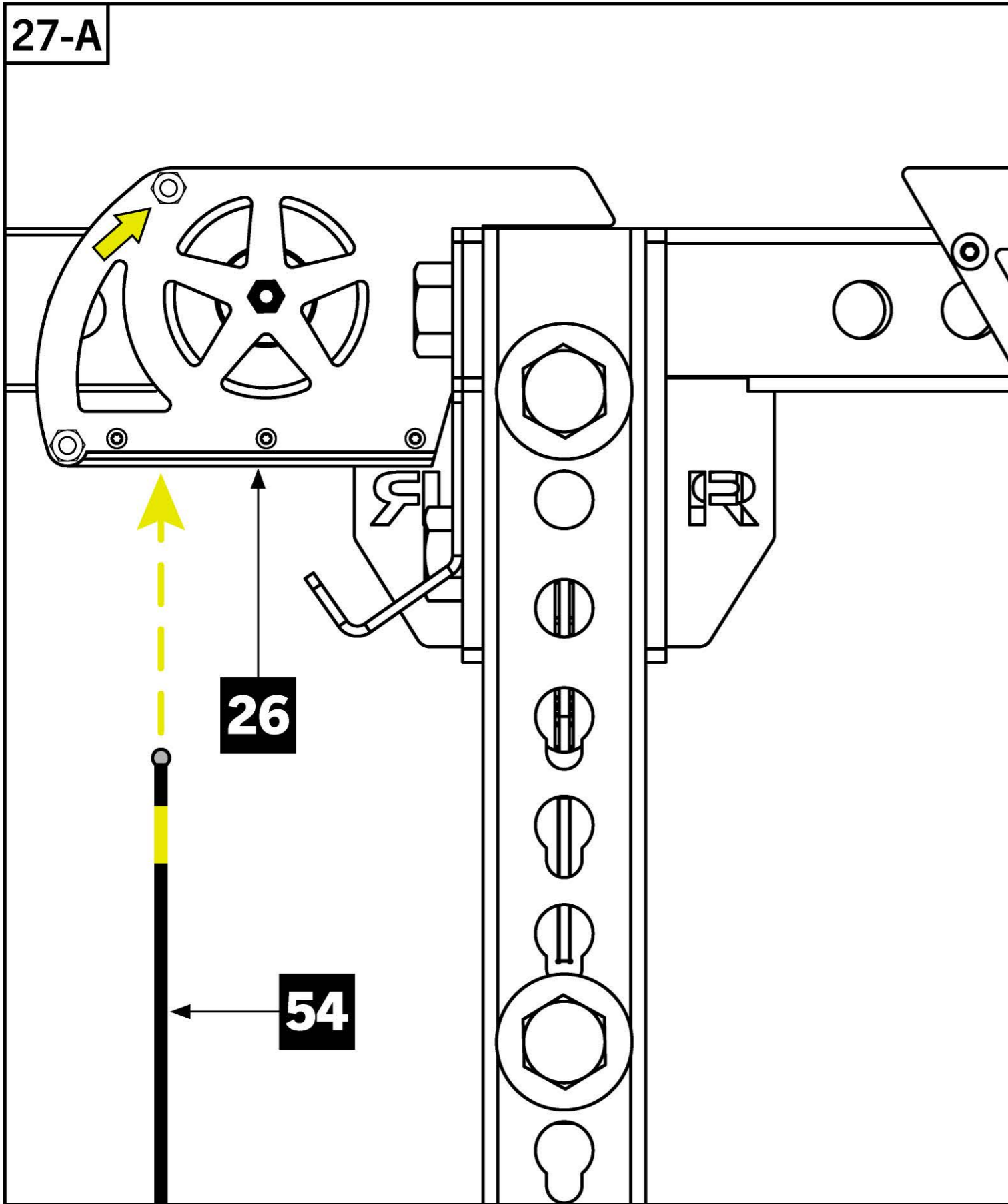
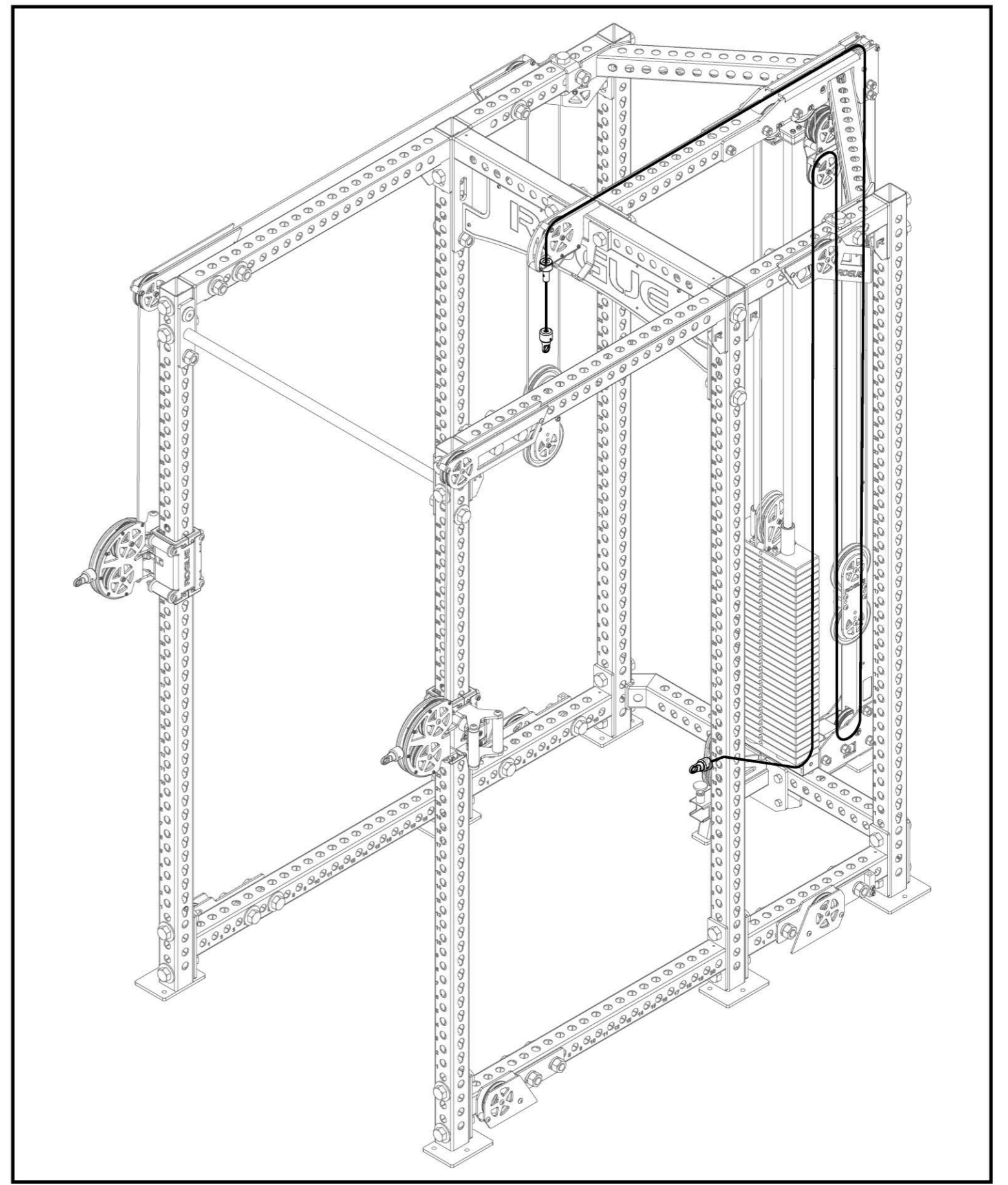

## STEP 28

- Feeding cable around the rear pulley of the Low Rear Pulley Assembly [29] and up. This is easiest accomplished by pulling most of slack through rear window on Rear Upright and then re-inserting.
- Feed cable around the bottom pulley in the Rear Peanut Pulley Assembly [49] and then back down again.
- Feed around the front pulley in the Low Rear Pulley Assembly, continuing diagonally up underneath the Weight Stack through the cutouts on Low Row Crossmember [18] and towards the Low Row Assembly.

### Note:

- Place finger through viewing windows to guide cable around pulleys as needed.

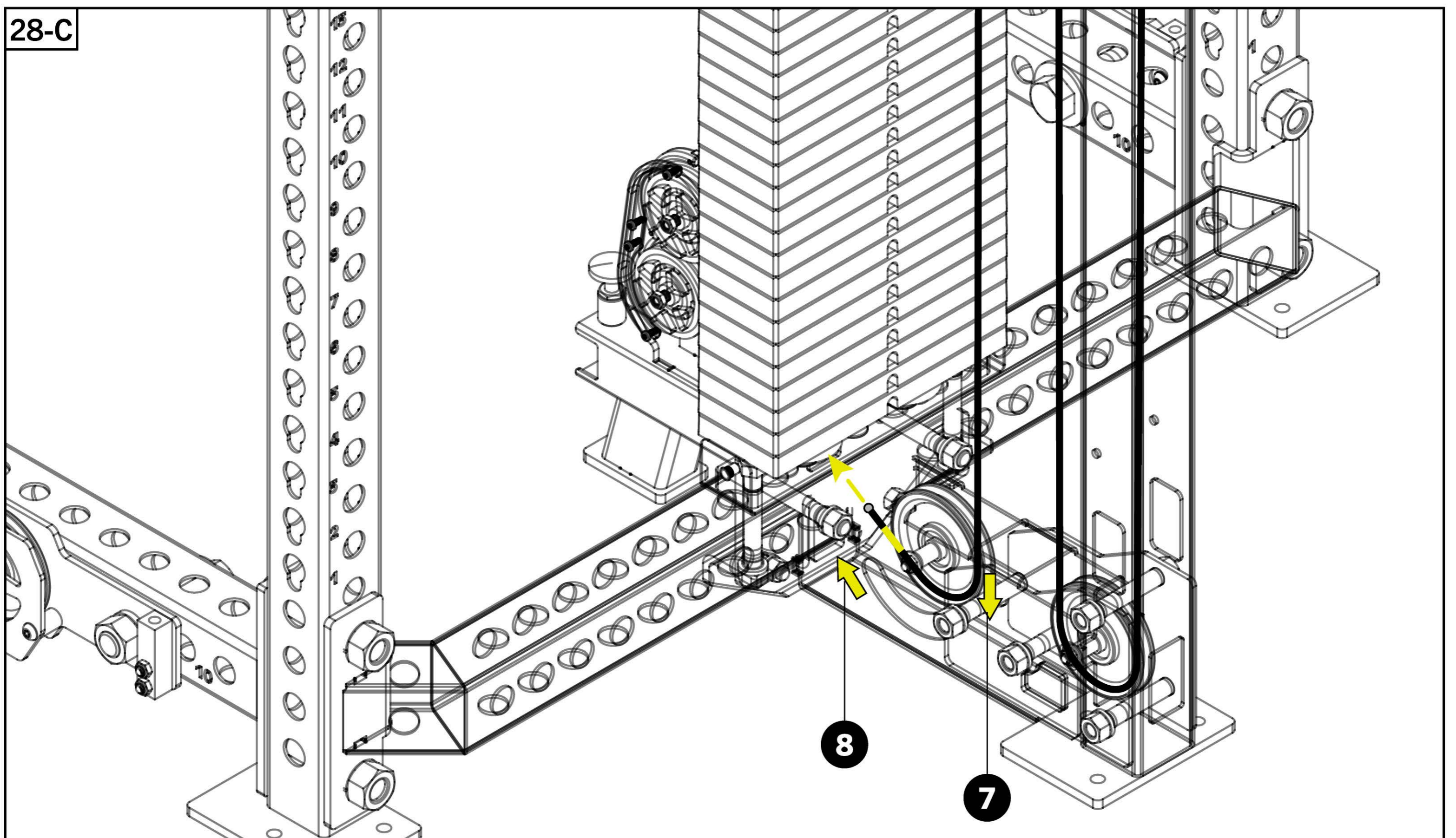
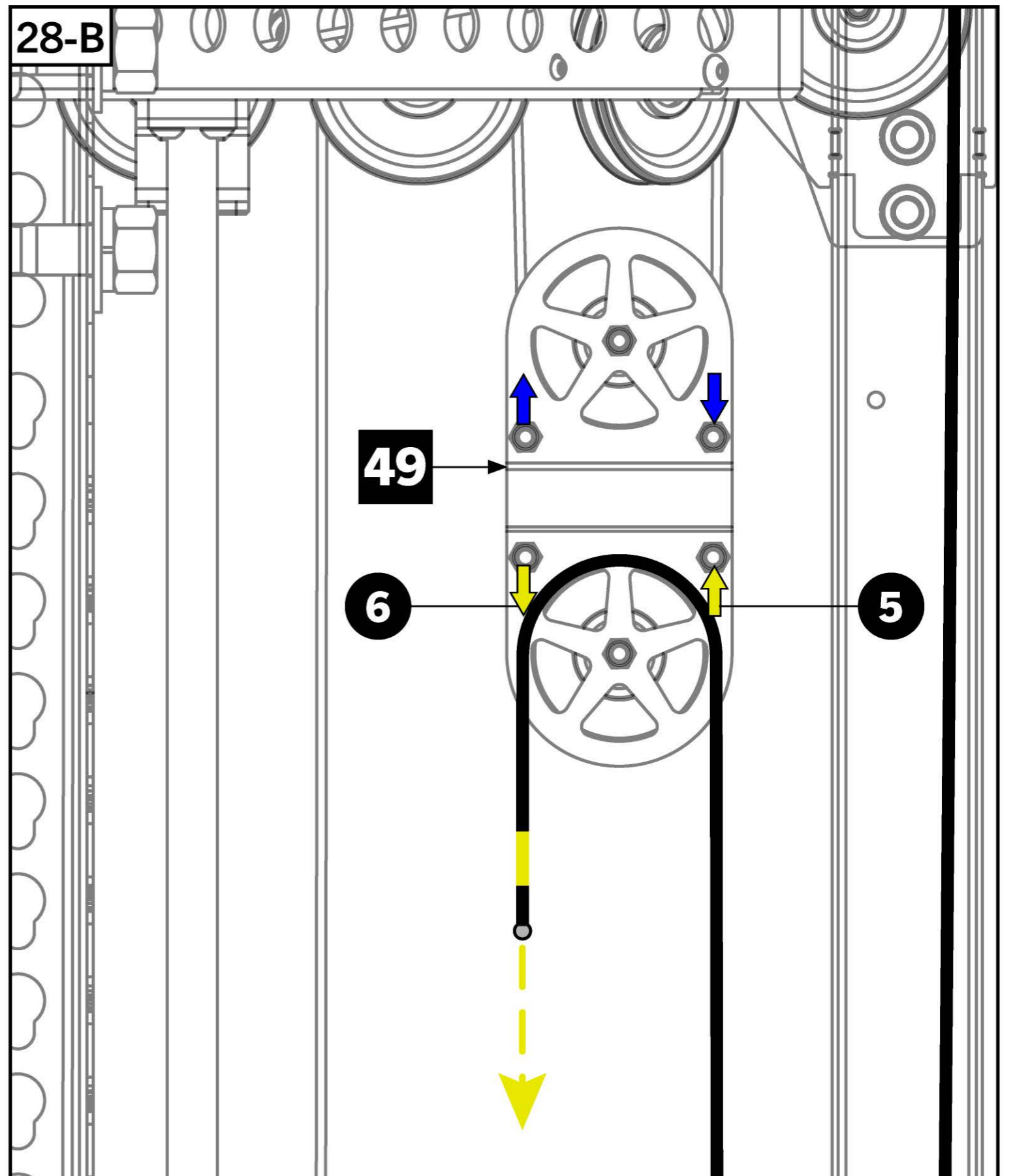
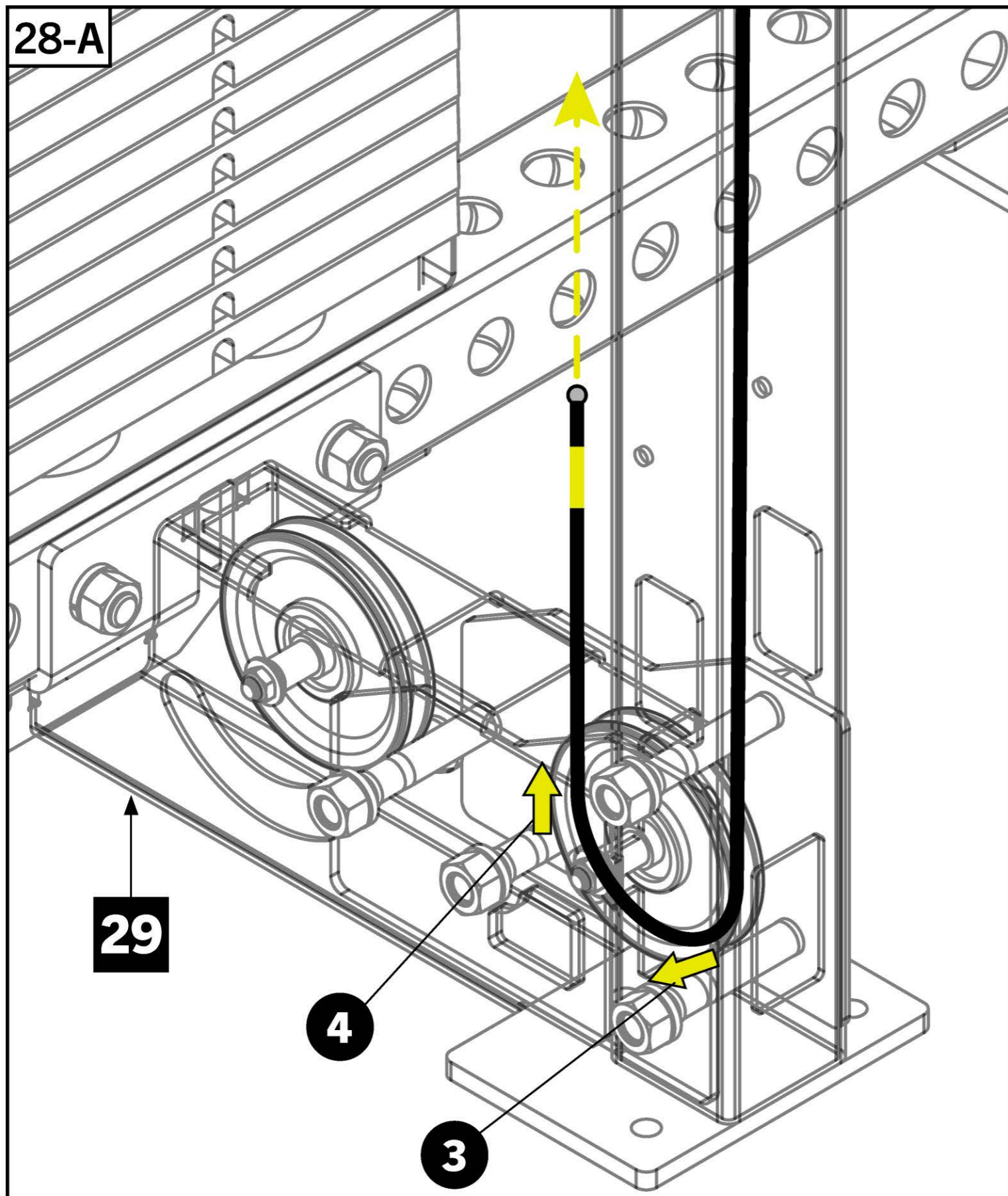
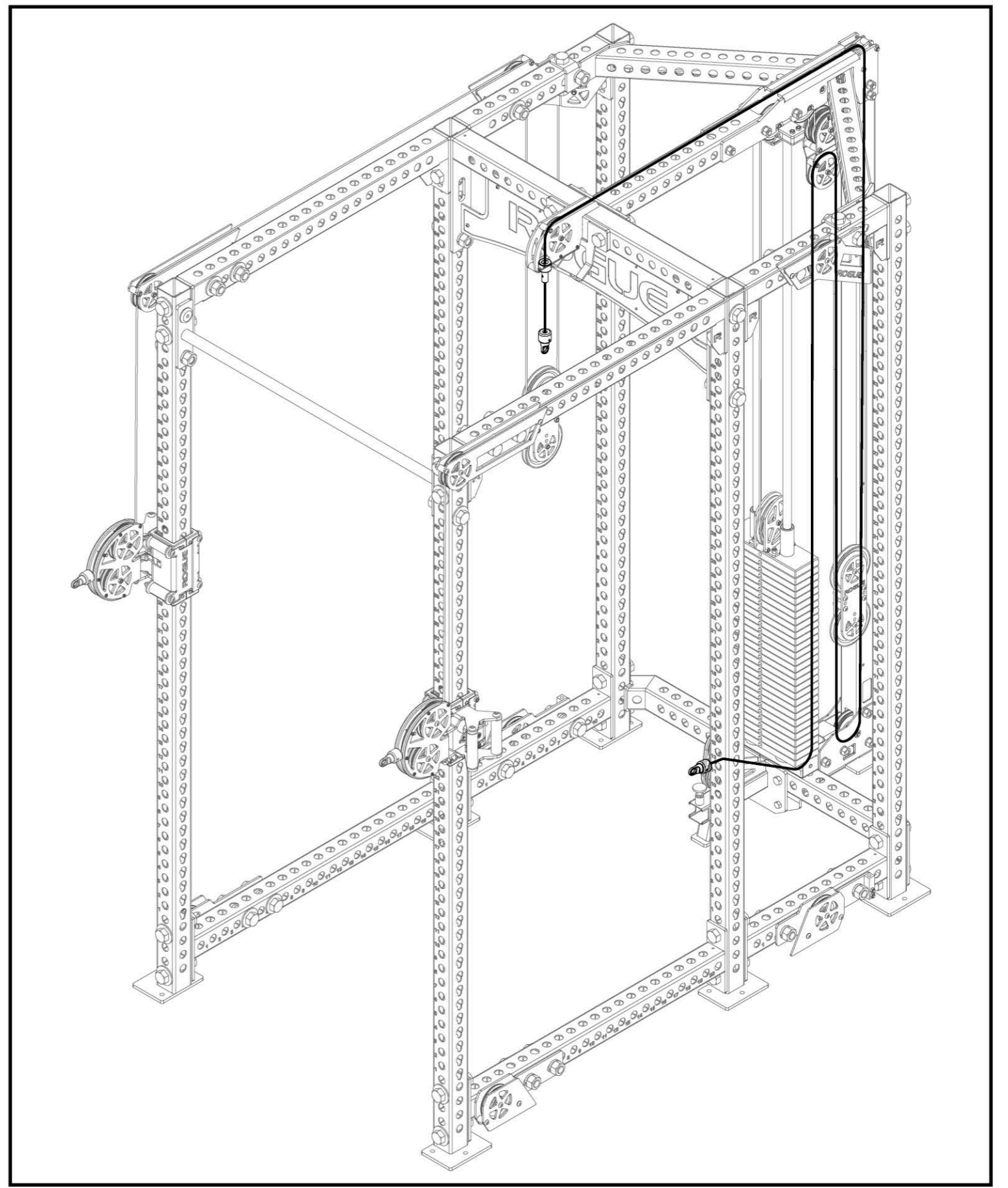

## STEP 29

### Tools Required:

- 3/32" Allen Key & 5/8" Wrench
- Feed cable out through the front of the Low Row Assembly [28], ensuring cable passes in between upper and lower pulleys.
- Remove yellow tag from Ball End of cable and pull cable out far enough to assemble Clevis.
- Assemble Clevis onto ball end of cable using the same procedure described on **STEP 26**.

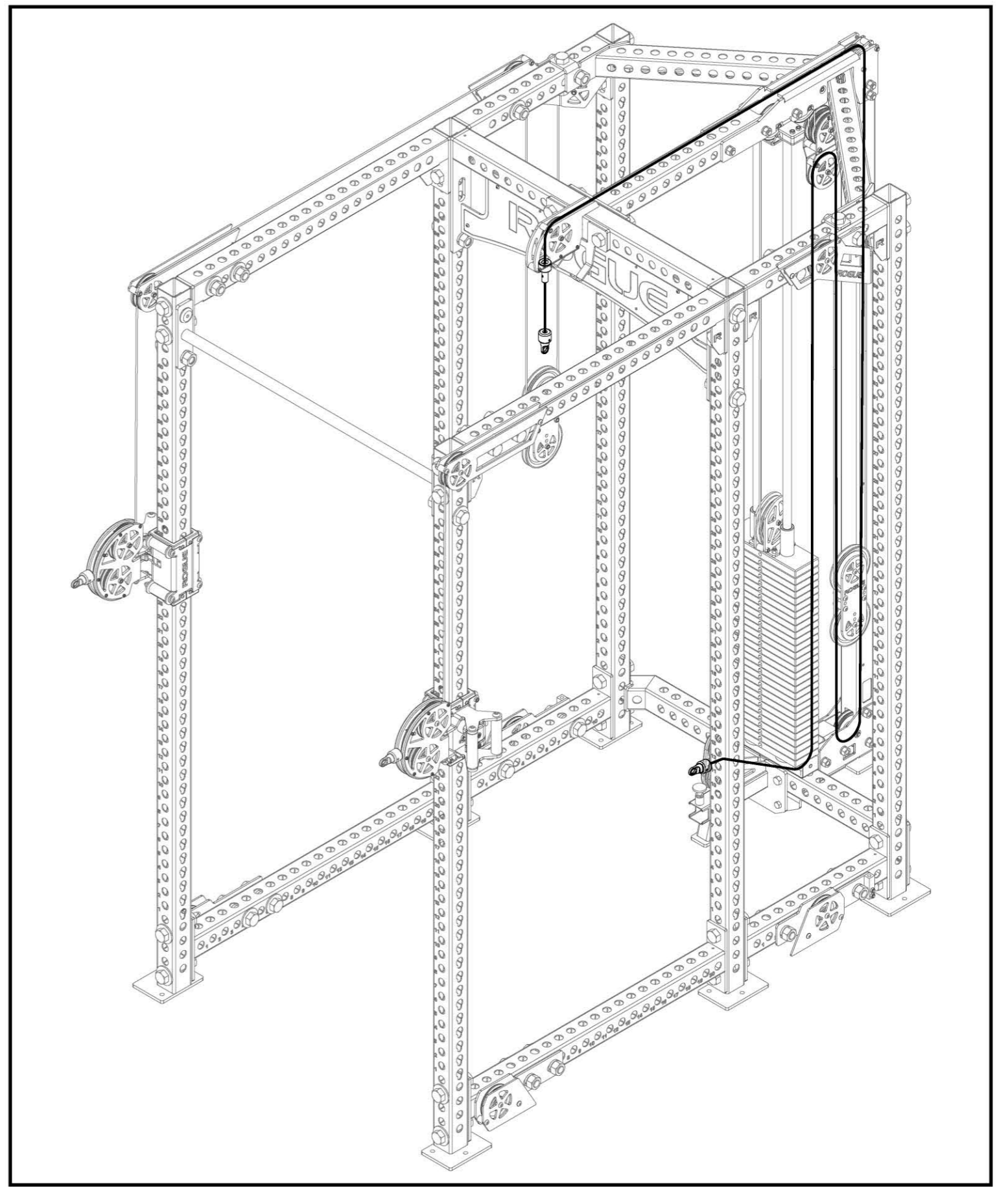

29-A

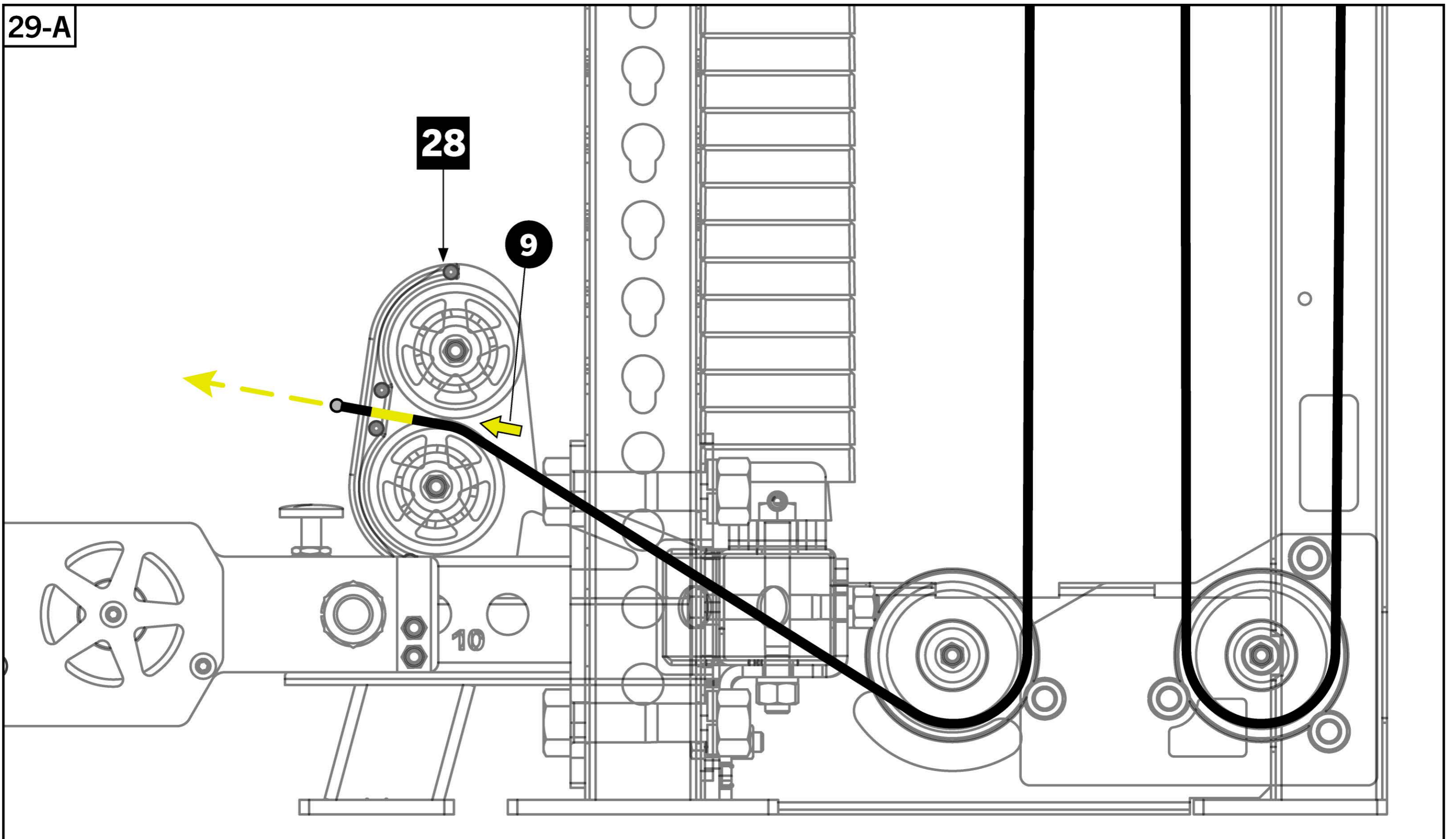

29-B

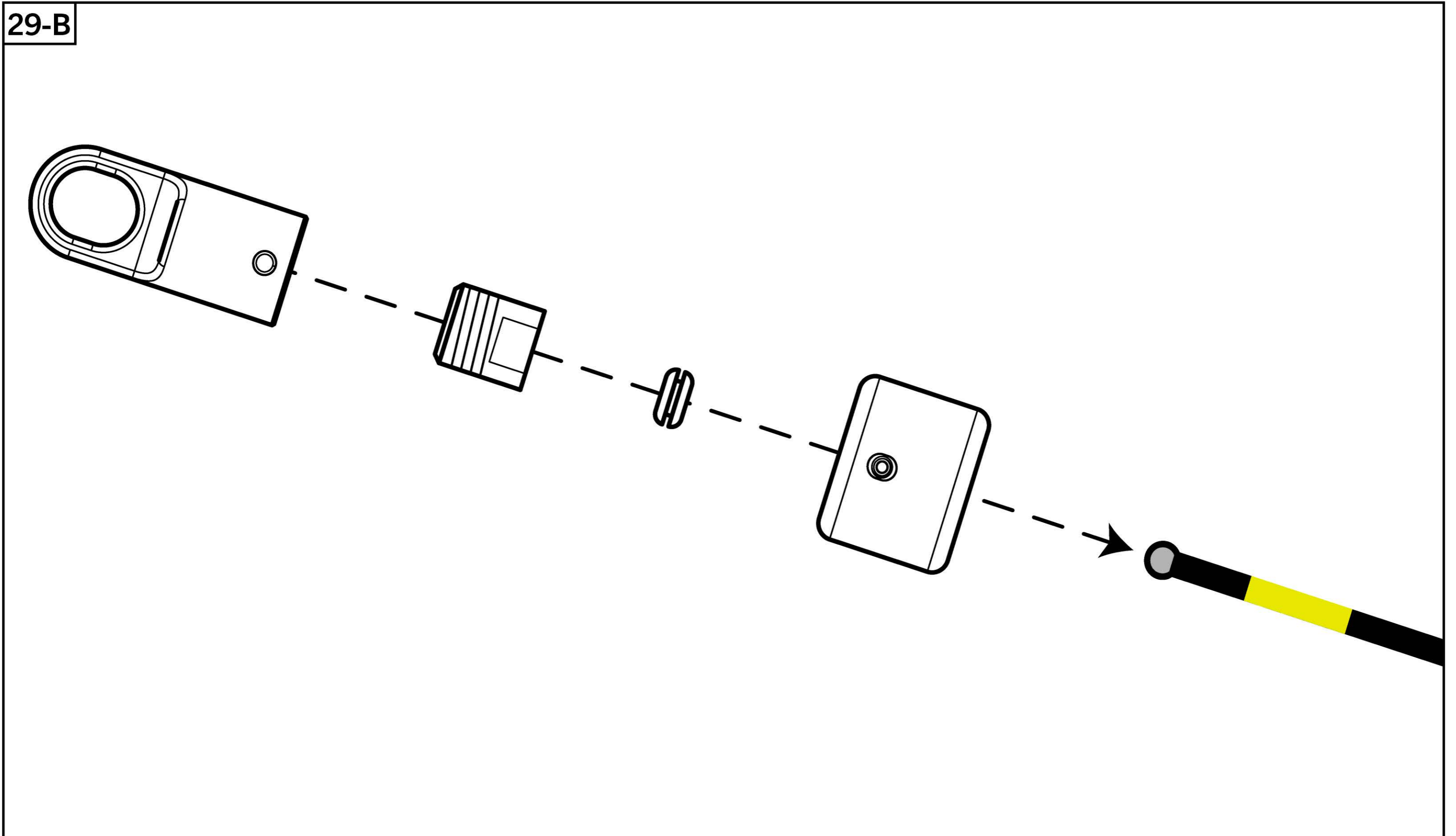

# STEP 30

## Tools Required:

- 7/32" Allen Key & 9/16" Wrench
- Remove Plastic Cable Retainers from **all** four Bottom Side Pulley Assemblies by removing 3/8" Button Head Screws.
- Remove only the lower Plastic Cable Retainers from both Side Peanut Pulleys [50].
- Hardware will be re-installed on **STEP 33**.

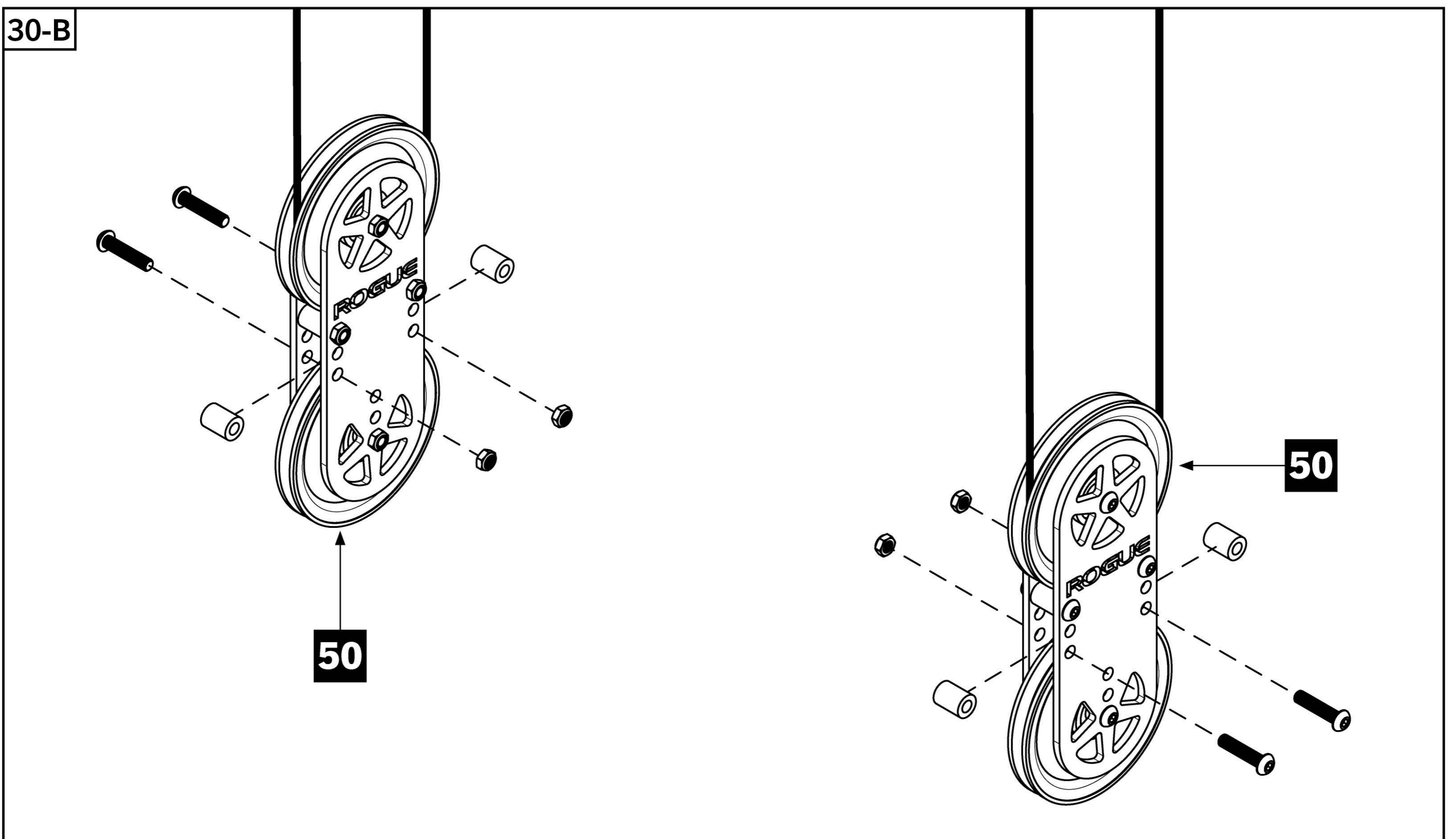
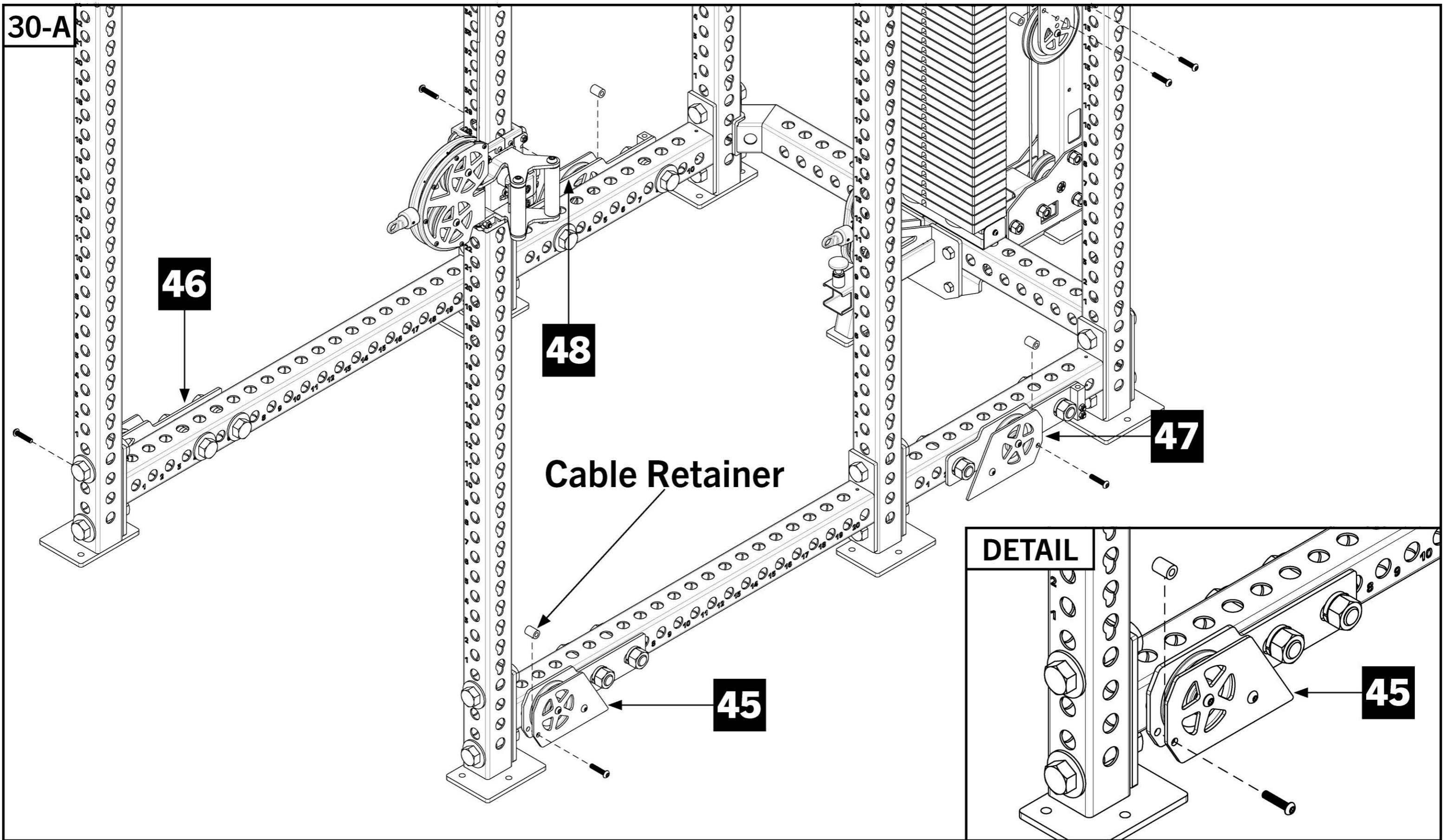
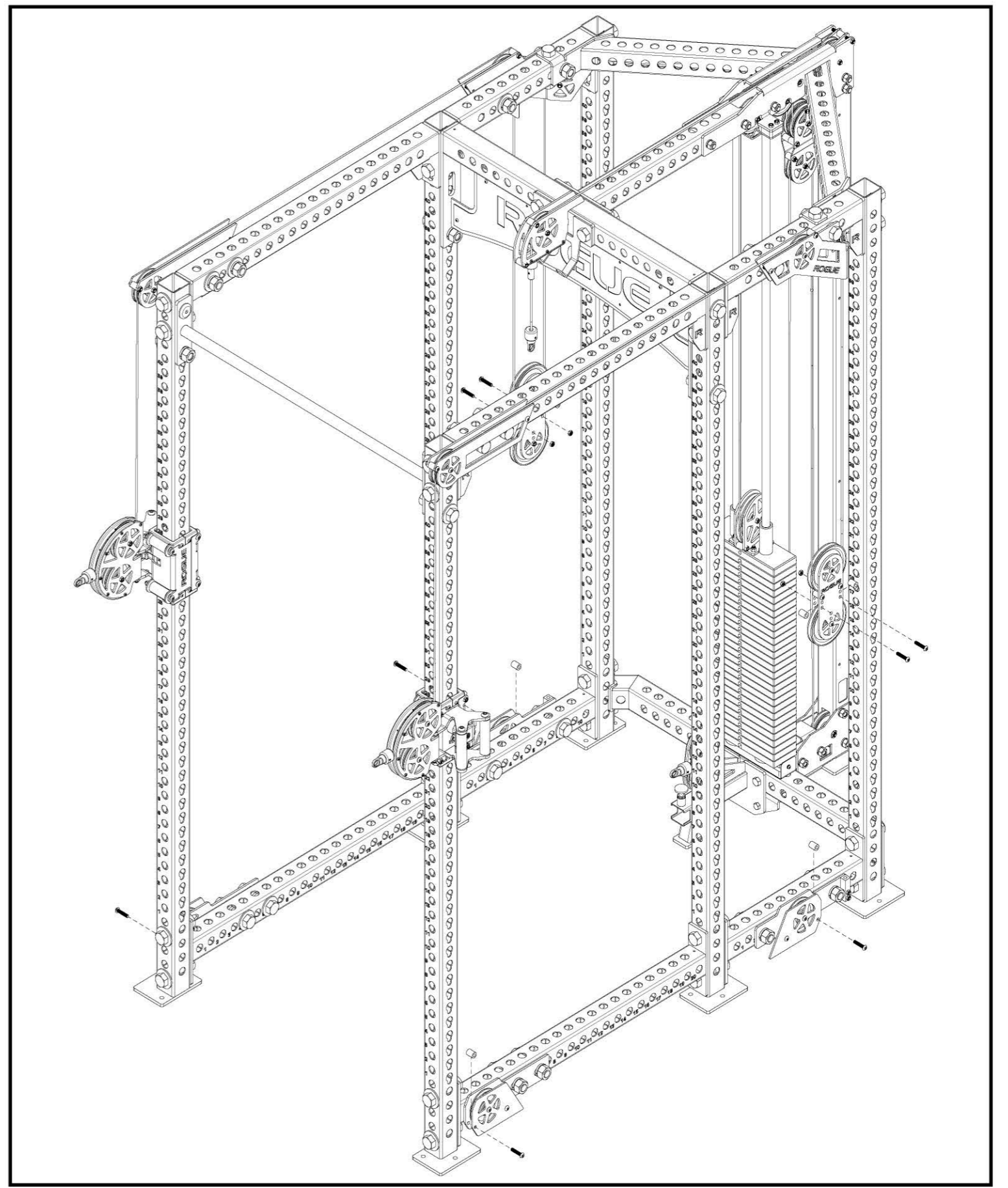

# STEP 31

## Tools Required:

- 3/4" Wrench
- Assemble one of the included Low Side Cables [55] (red tag) onto RH side of rack by inserting the tagless end into stop block on back of Swivel Trolley RH [19].
- Loosen the hex nut if needed to ensure approximately 1/2" of threads are showing between the bolt head and nut.
- Tighten the bottom bolt head until the nut is tight against the stop block.
- Feed the other end of cable with red tag down around the pulley on Bottom Front Pulley Assembly and continue towards back of rack.

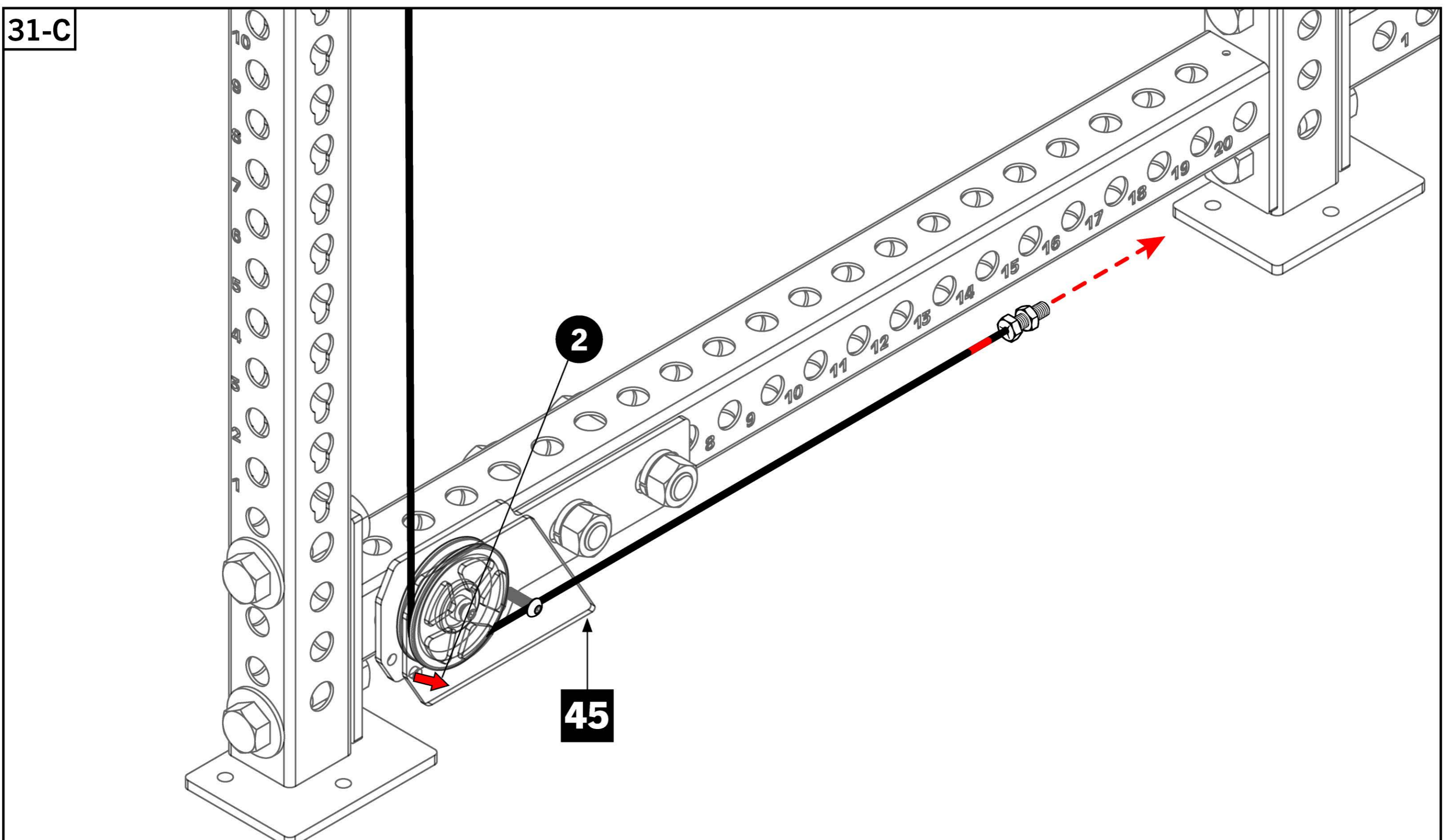
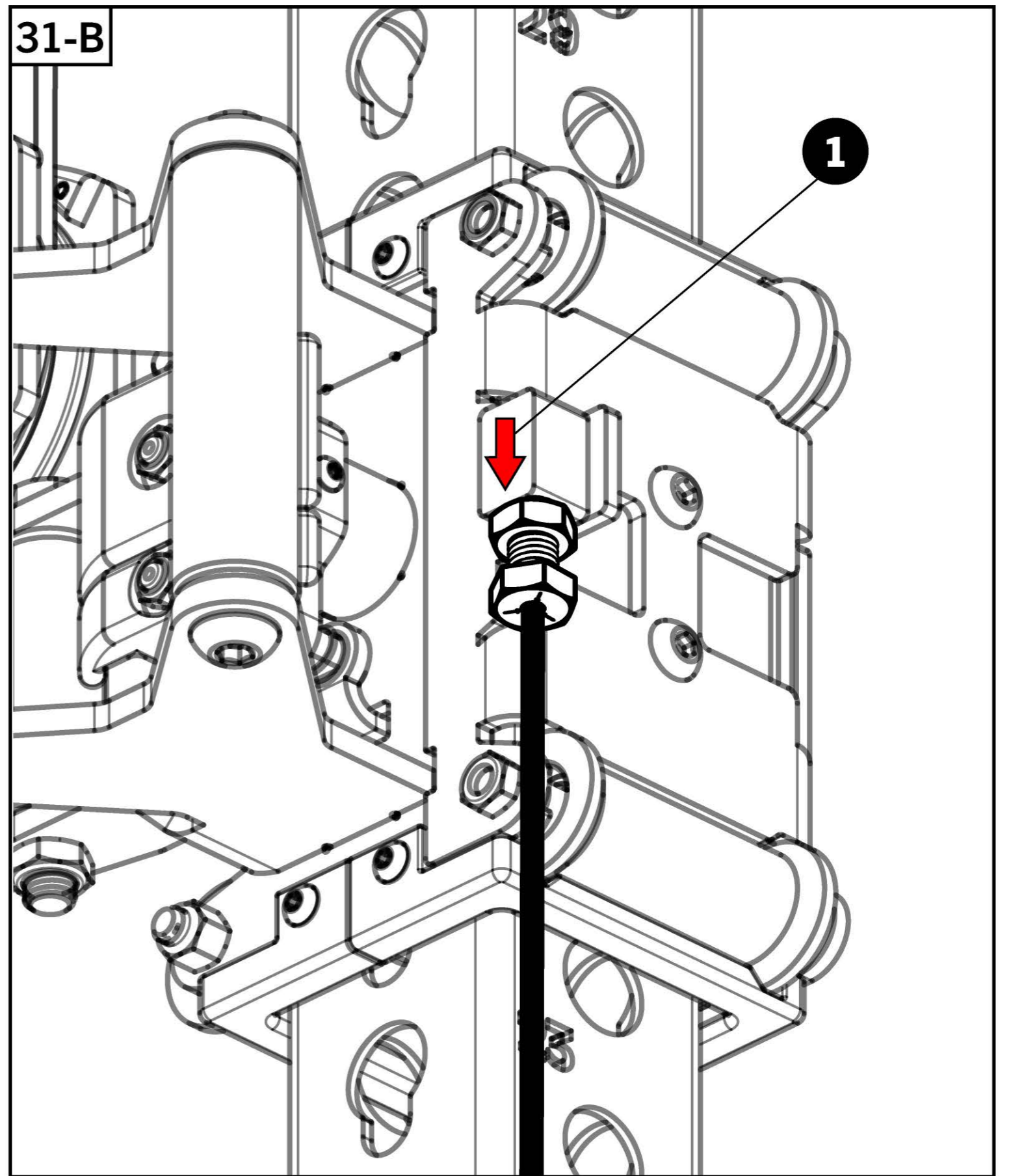
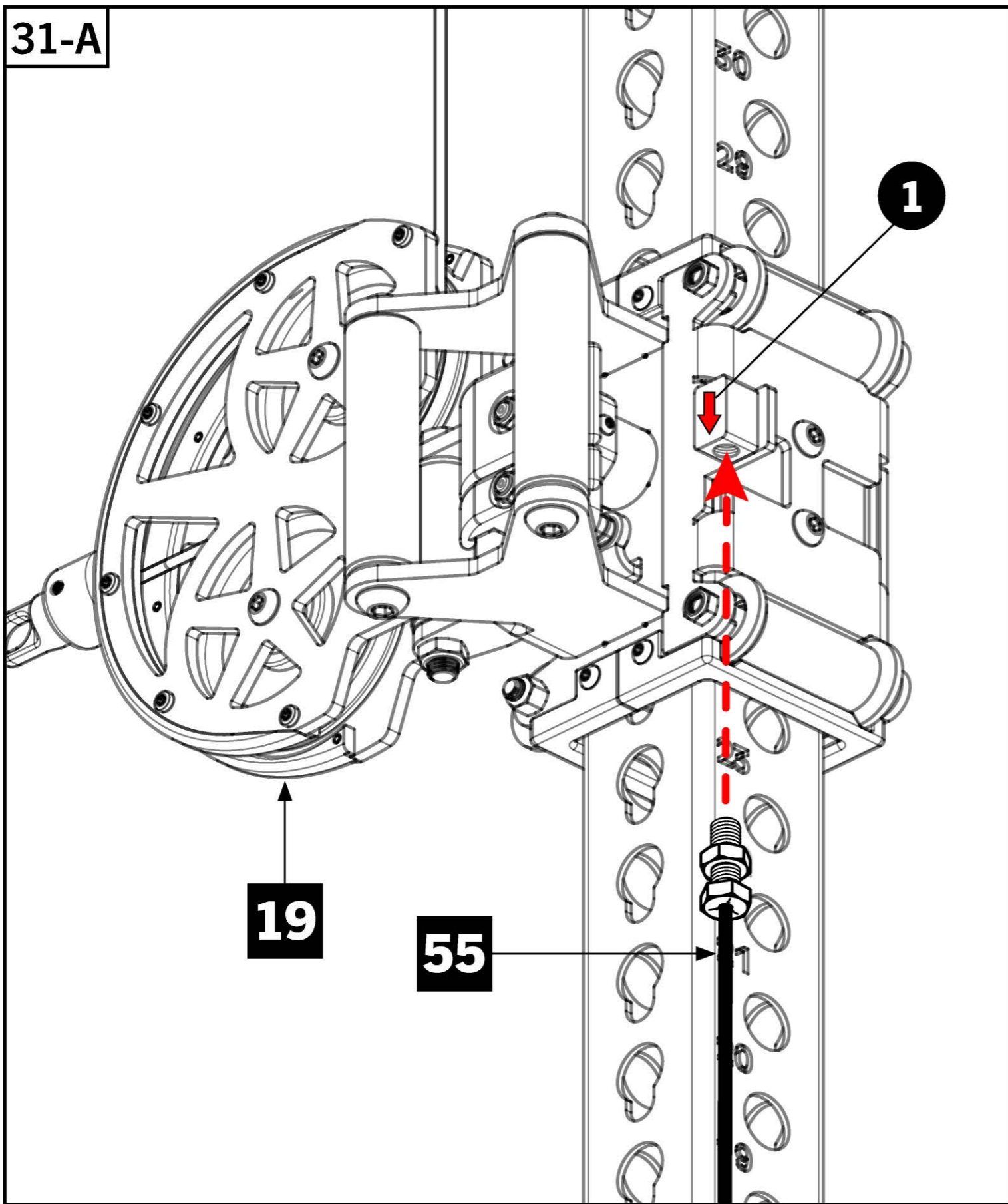
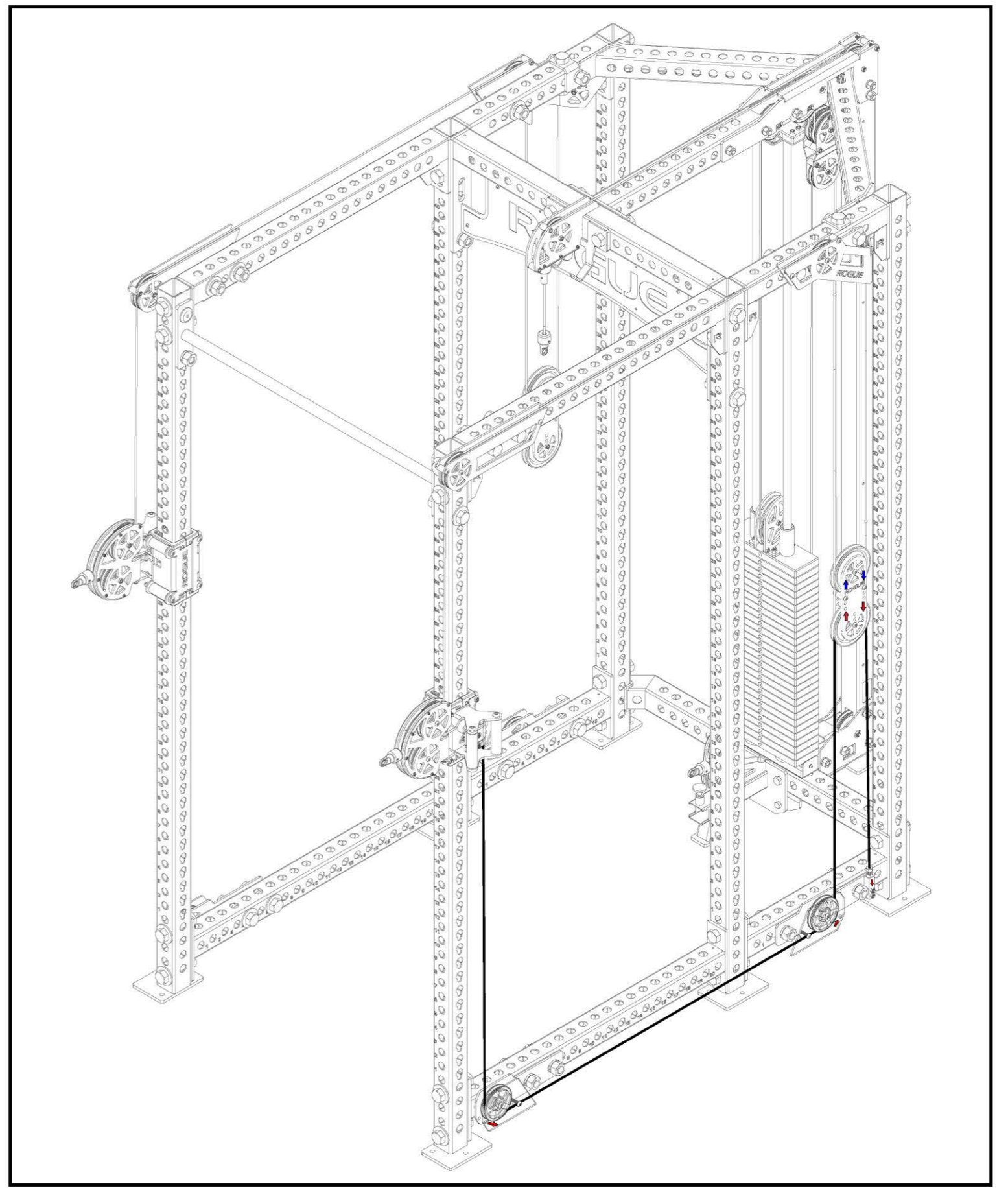

# STEP 32

## Tools Required:

- 3/4" Wrench
- Continue feeding around the pulley on Bottom Rear Pulley Assembly and up around the lower Side Peanut Pulley [50], following the arrow indicator directions.
- Insert threaded end into stop block at the back of Bottom Rear Side Pulley Assembly [47] and screw tight, ensuring 1/2" of threads showing between 3/4" bolt head and hex nut.

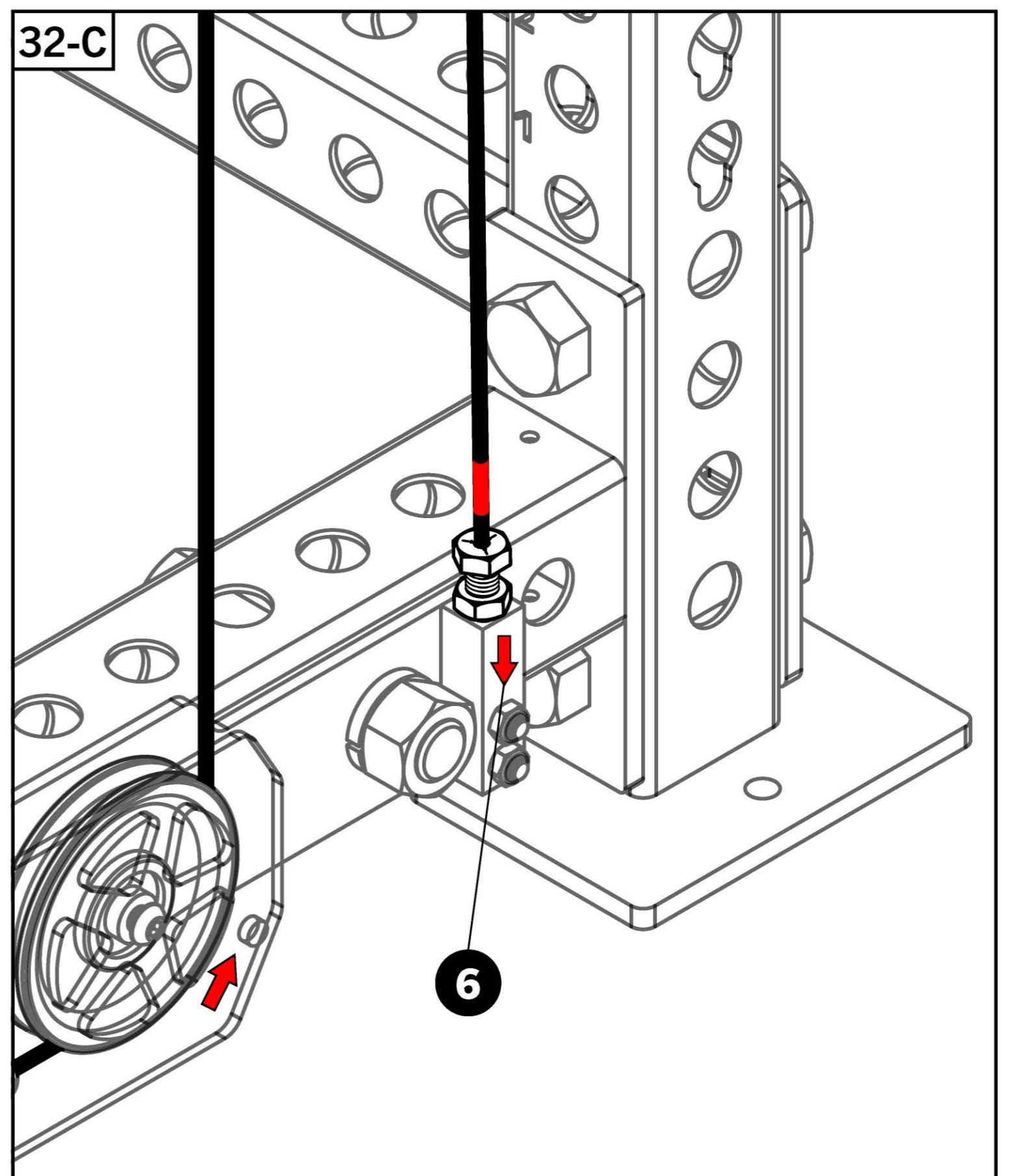
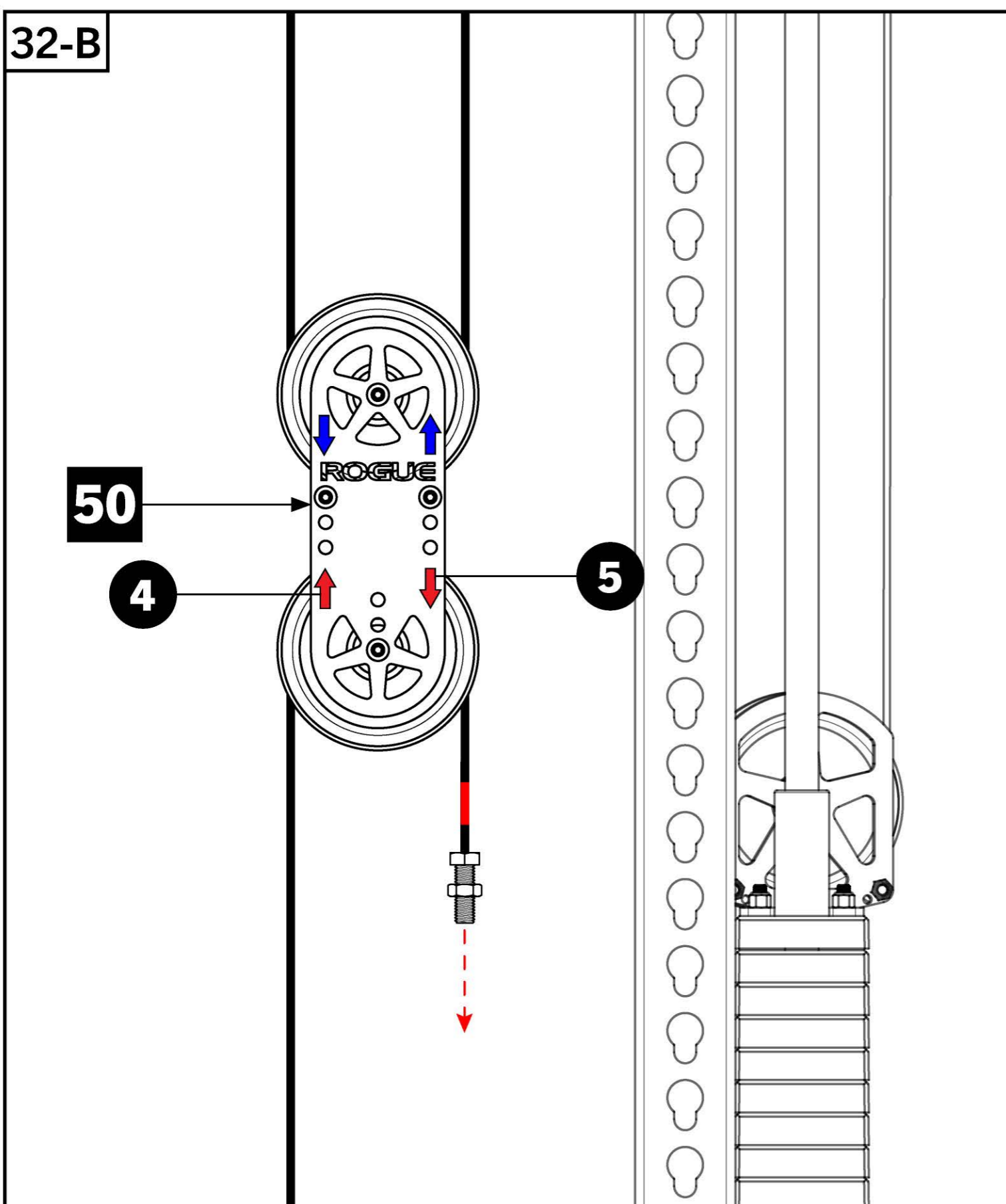
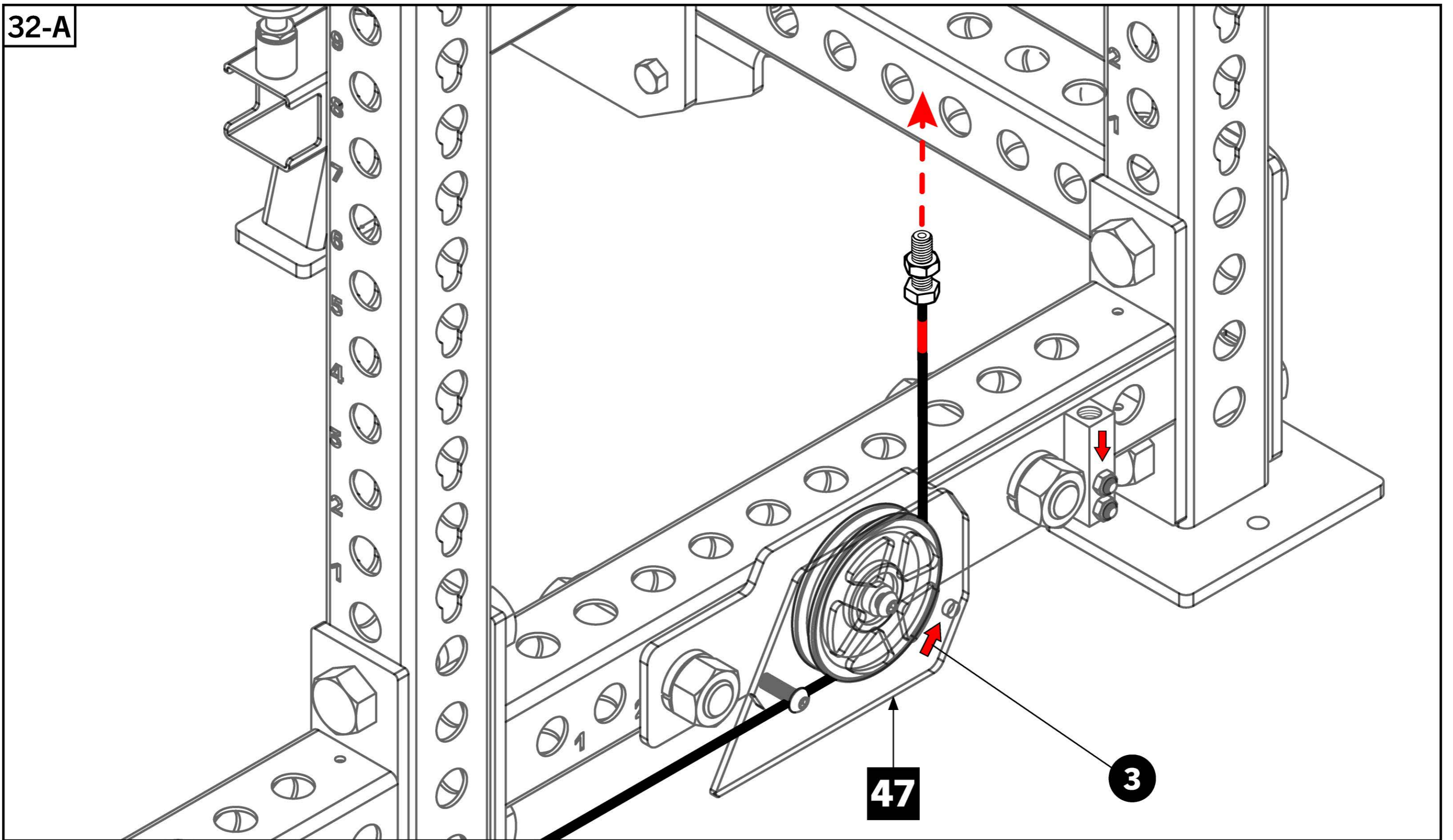
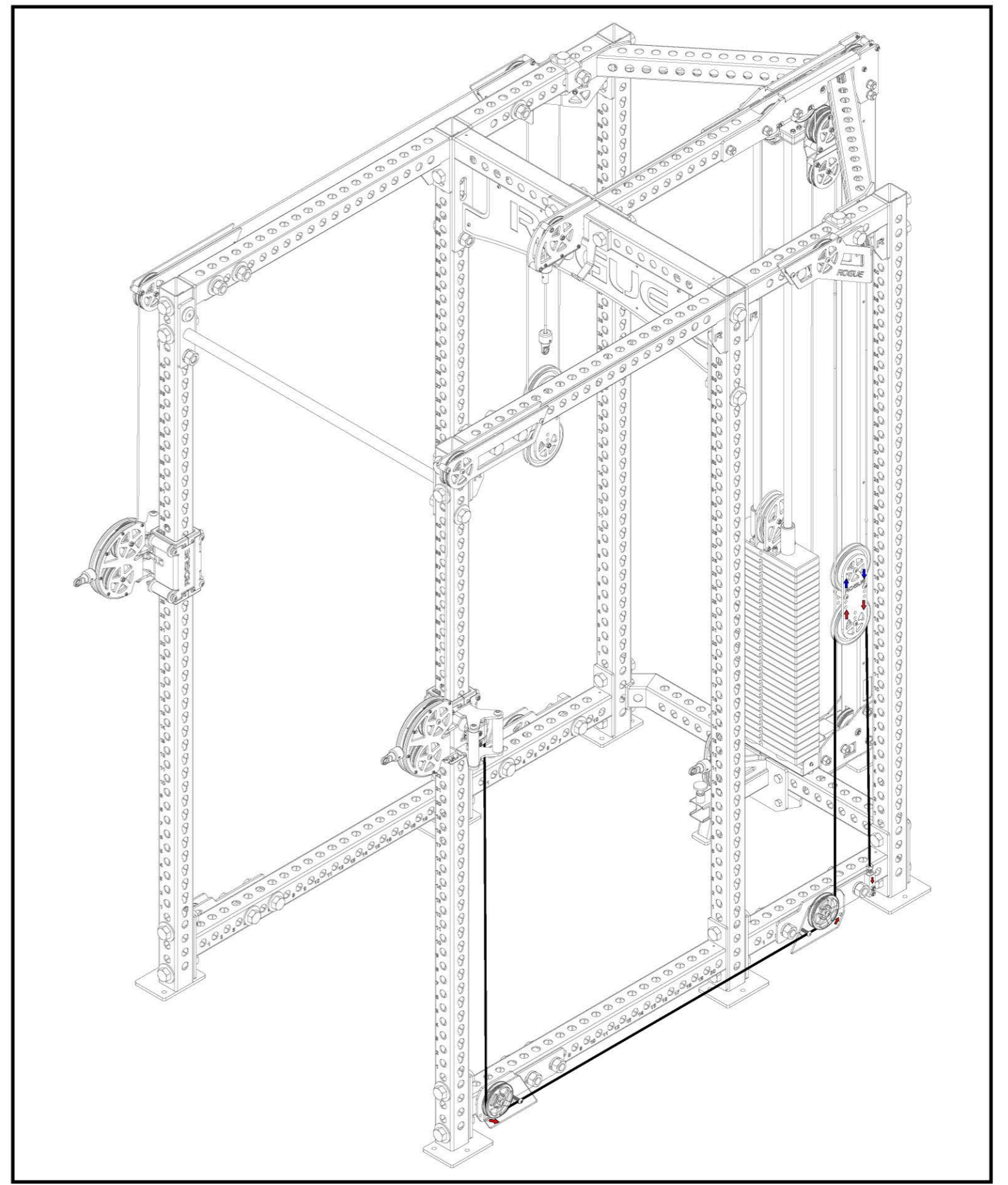

# STEP 33

## Tools Required:

- 3/4" Wrench
- **33-A:** Follow **STEP 31 & 32** again to assemble the remaining Low Side Cable (red tag) on the **Left Hand side of rack**.
- Start at stop block on the Swivel Trolley LH [20] and end at stop block on the Bottom Rear Side Pulley - LH [48].

## Tools Required:

- 7/32" Allen Key & 9/16" Wrench
- **33-B:** Re-install Plastic Cable Retainers on **all four** Bottom Side Pulley Assemblies and both Side Peanut Pulleys. Fully Tighten.

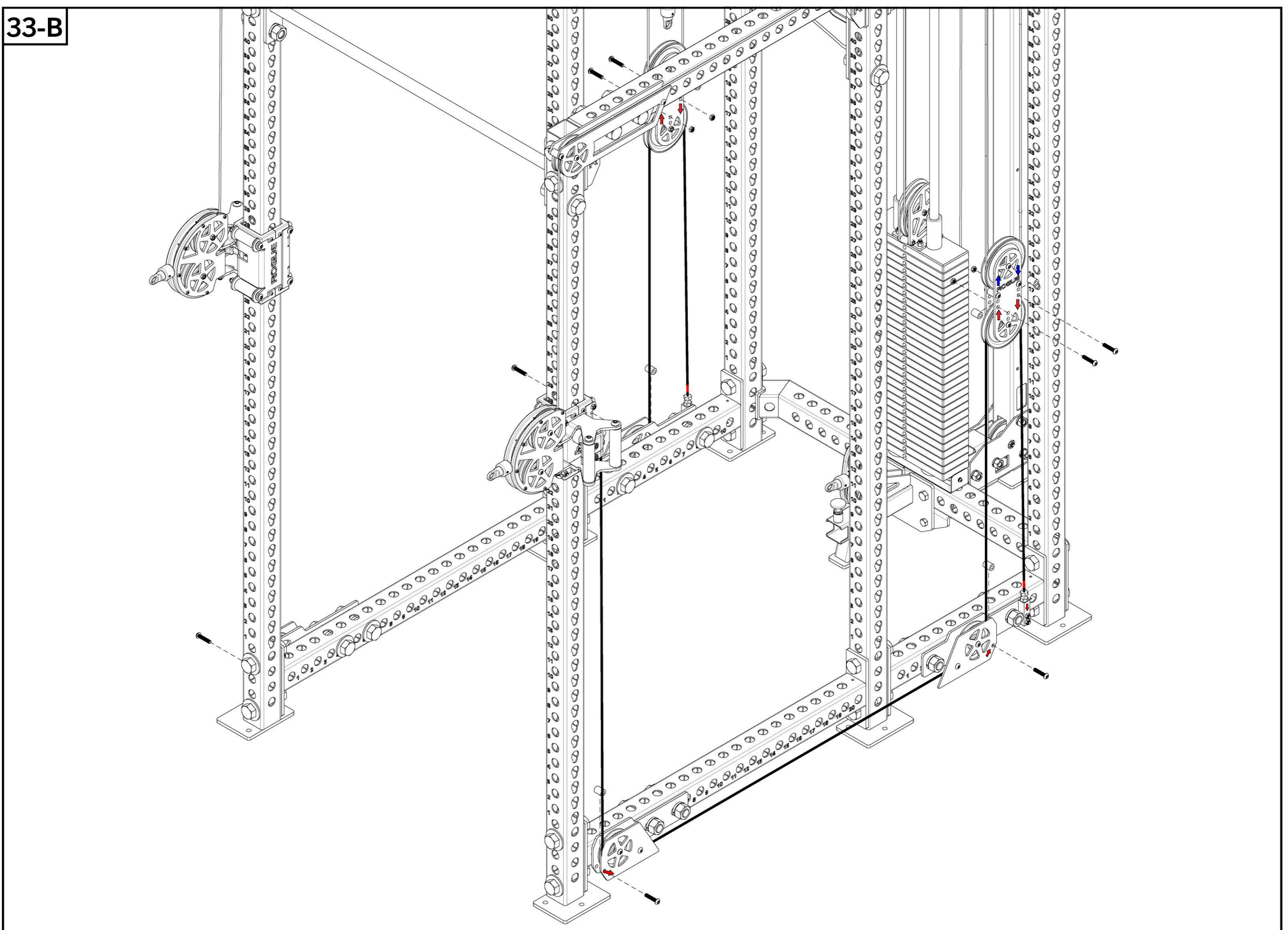
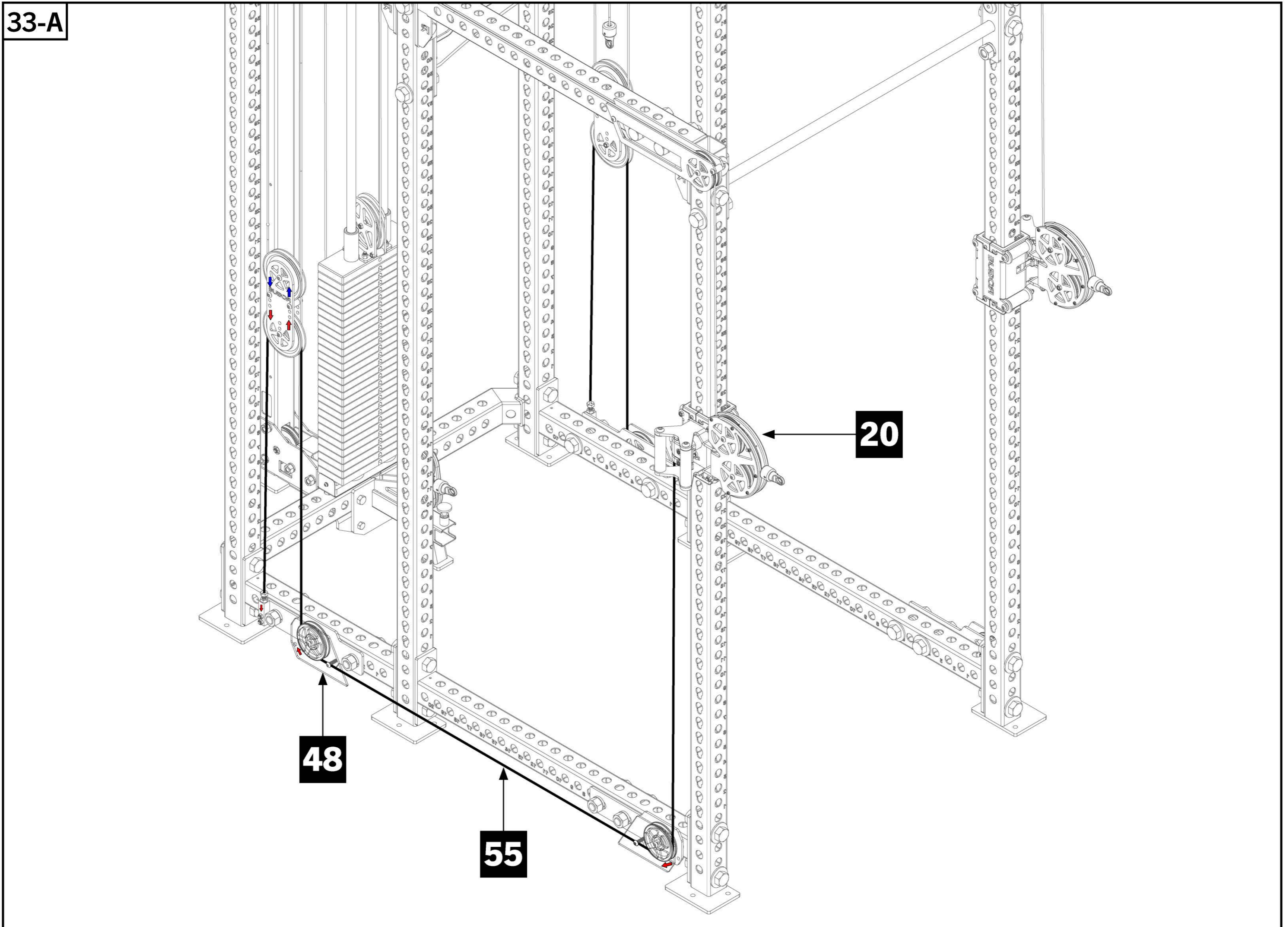

# STEP 34

## Tools Required:

- 7/32" Allen Key
- Remove eight 3/8" Button Head Screws located on the rear of the Front Side Pulley Assemblies and the front of the Rear Side Pulley Assemblies.
- Fasten the Top Cable Cover Rails [39] between the Front and Rear Top Side Pulley Assemblies by aligning holes and reinstalling the 3/8" Button Head Screws.
- Repeat this process on the bottom of your rack to install the Low Cable Cover Rails [40].
- **!** Note the orientation of the Rogue logos in relation to the rack. Ensure the cable opening is facing upward on the Top Cable Covers and downward on the Low Covers.

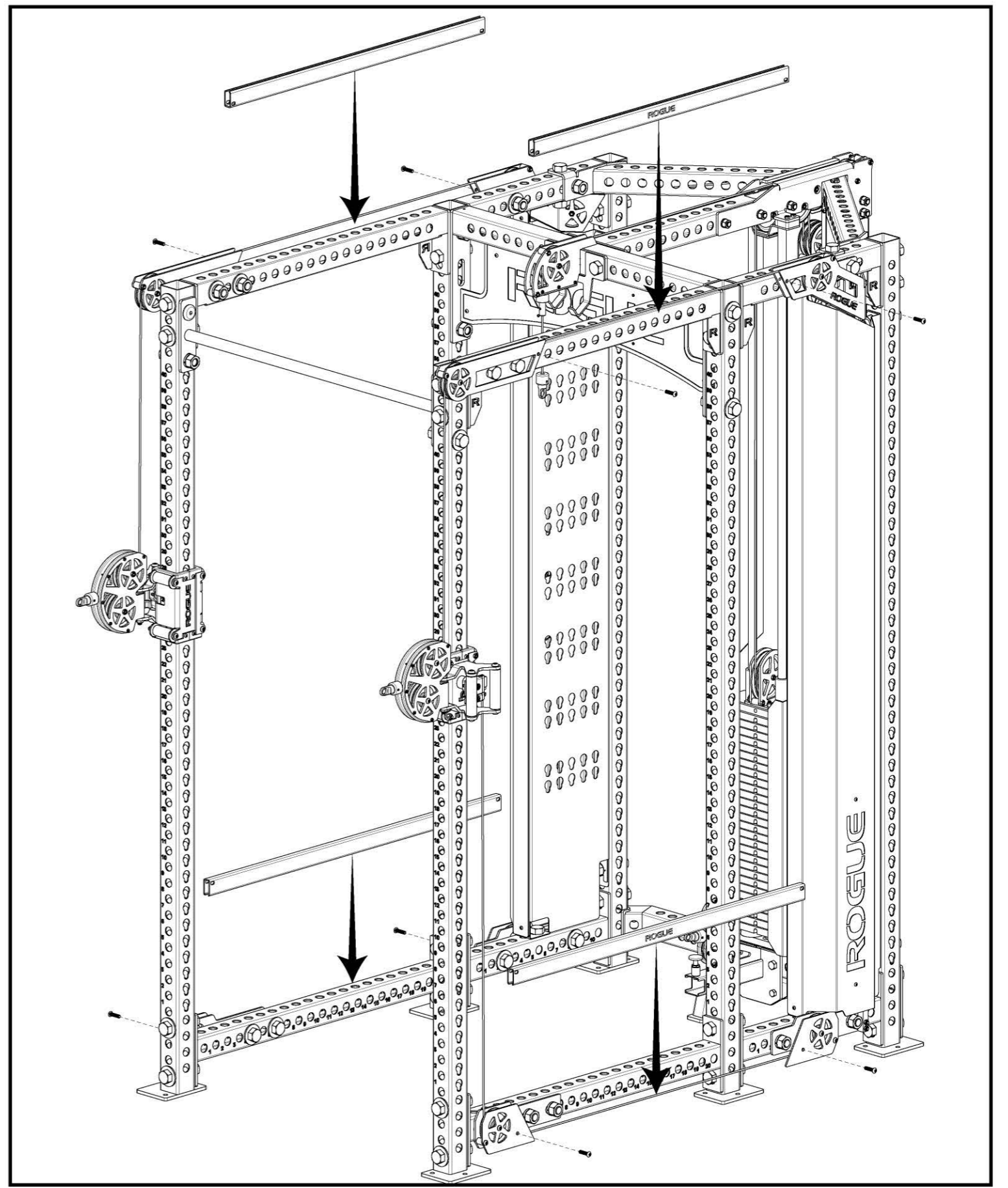

34-A

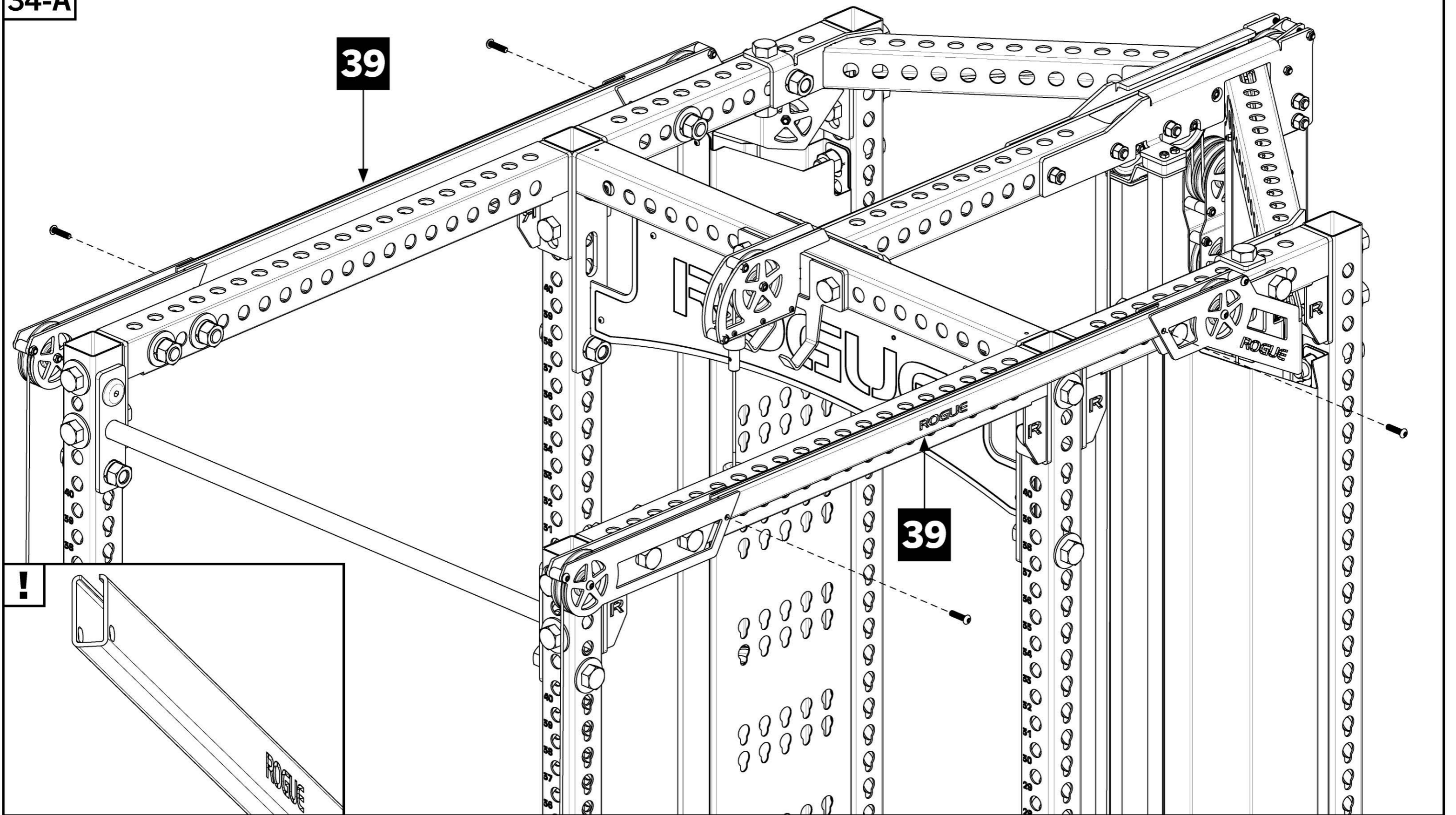

34-B

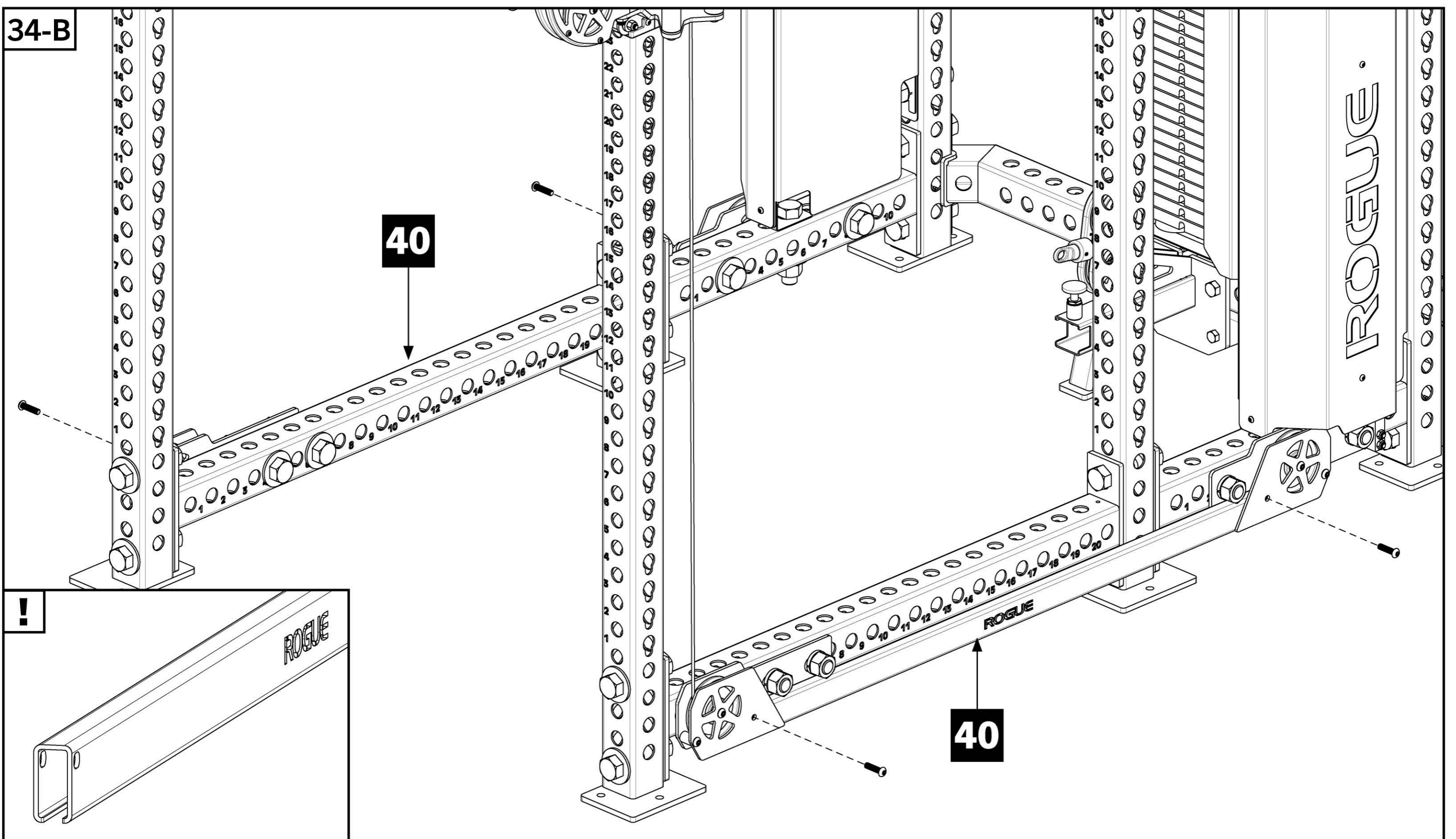



# STEP 35

## Tools Required:

- 1-1/2" Wrench, 1/8" Allen Key
- If modifying existing rack with add-on kit, skip to **35-B**.
- Place Key Washer over the Key Nut on the Plate Storage Post shown in **Detail** view.
- Assemble Plate Storage Pins [8] on rear Monster Uprights at desired hole heights.
- Slide Plate Storage Spacers [57] all the way down Plate Storage Pins with the set screws oriented on the bottom of Spacers as shown in **35-C**.
- Fully tighten set screws using 1/8" Allen Key.

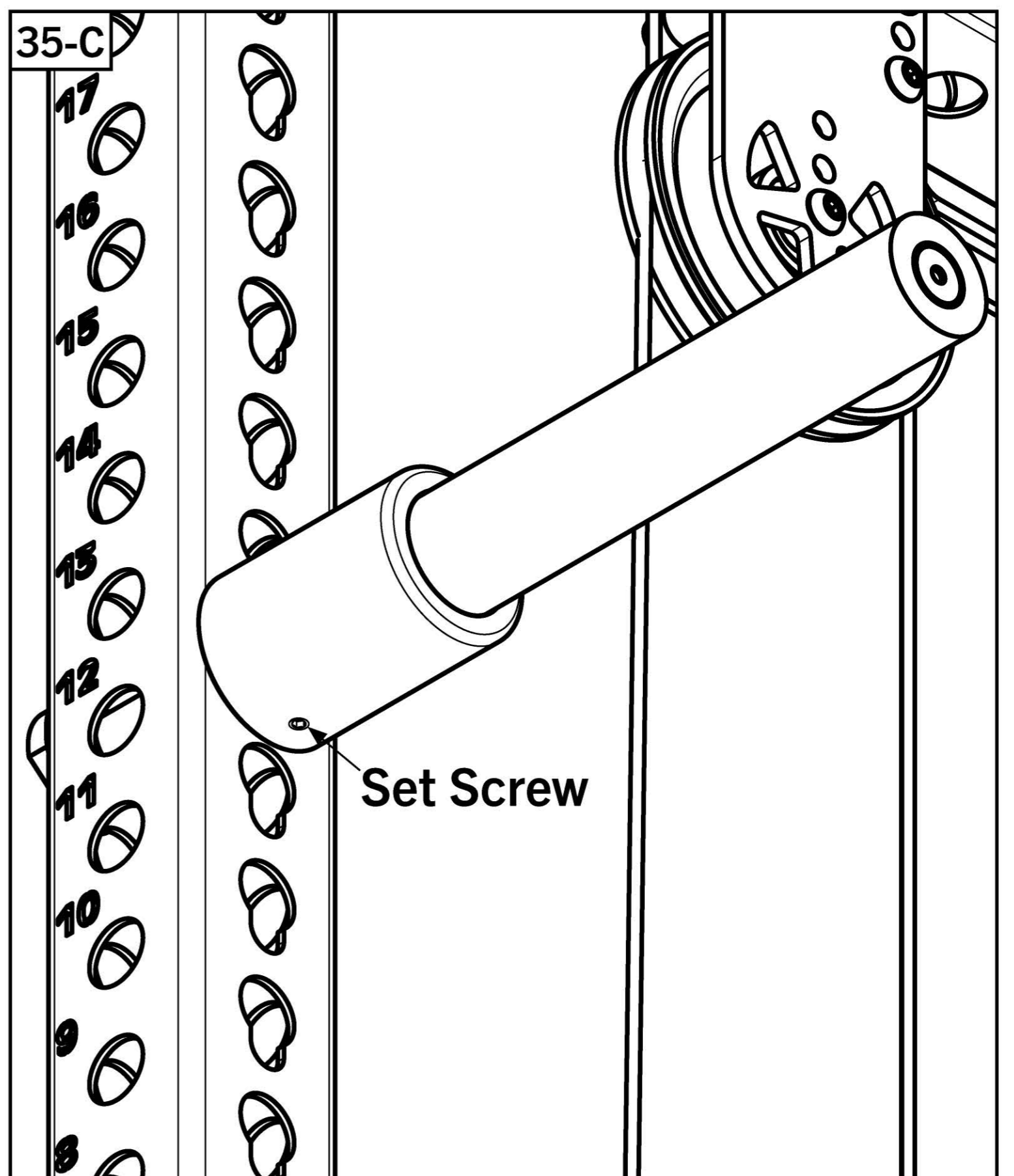
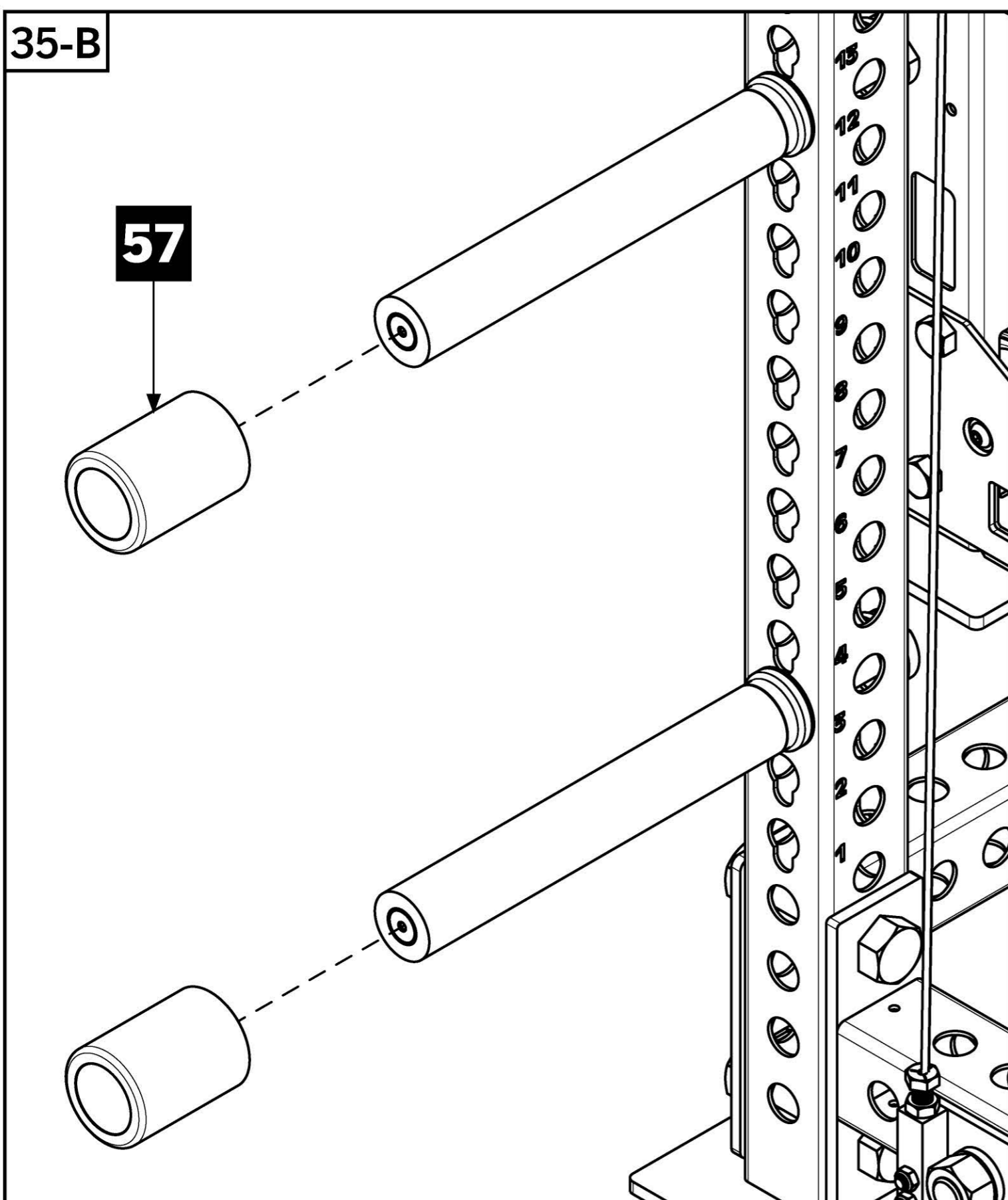
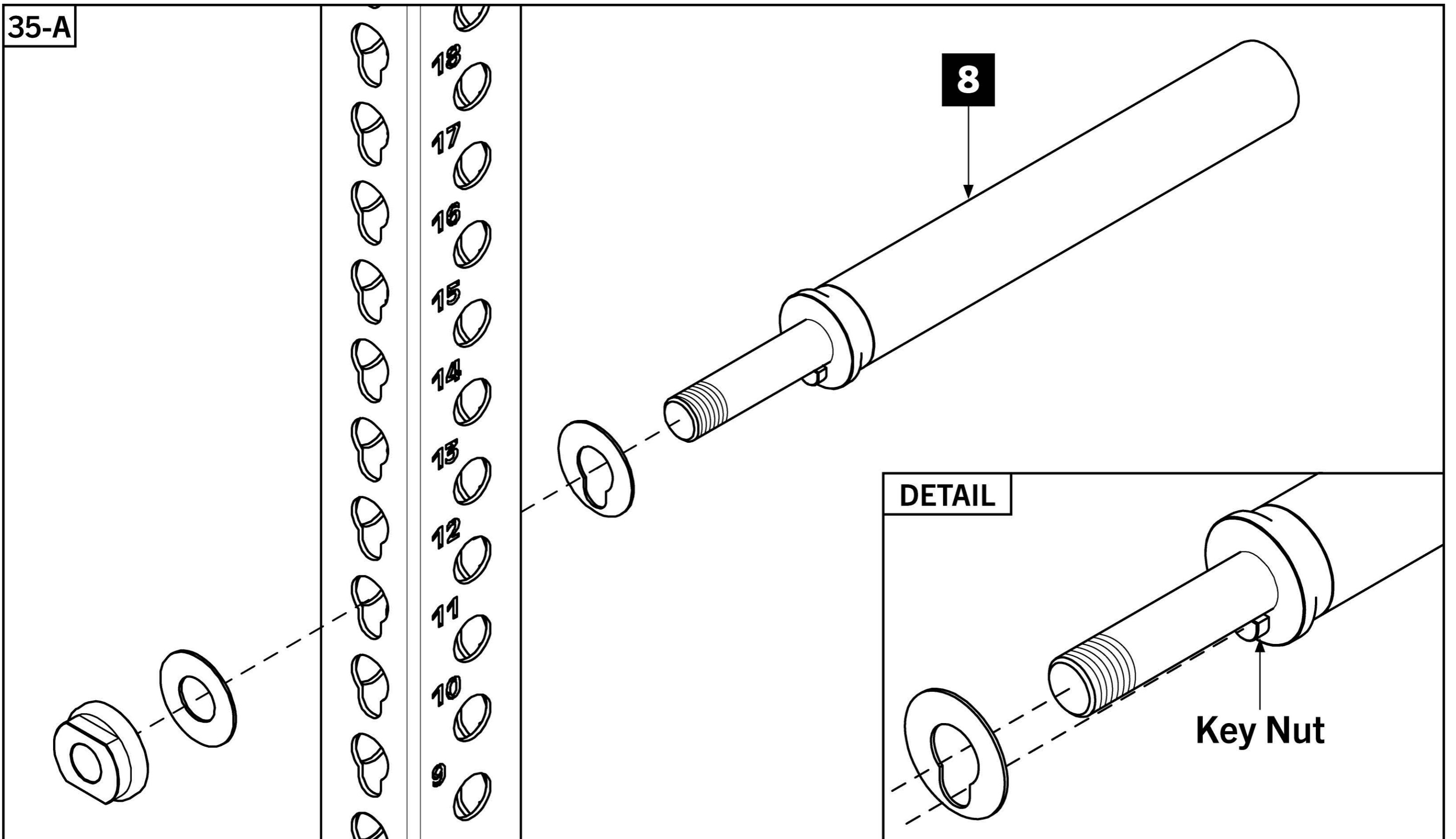
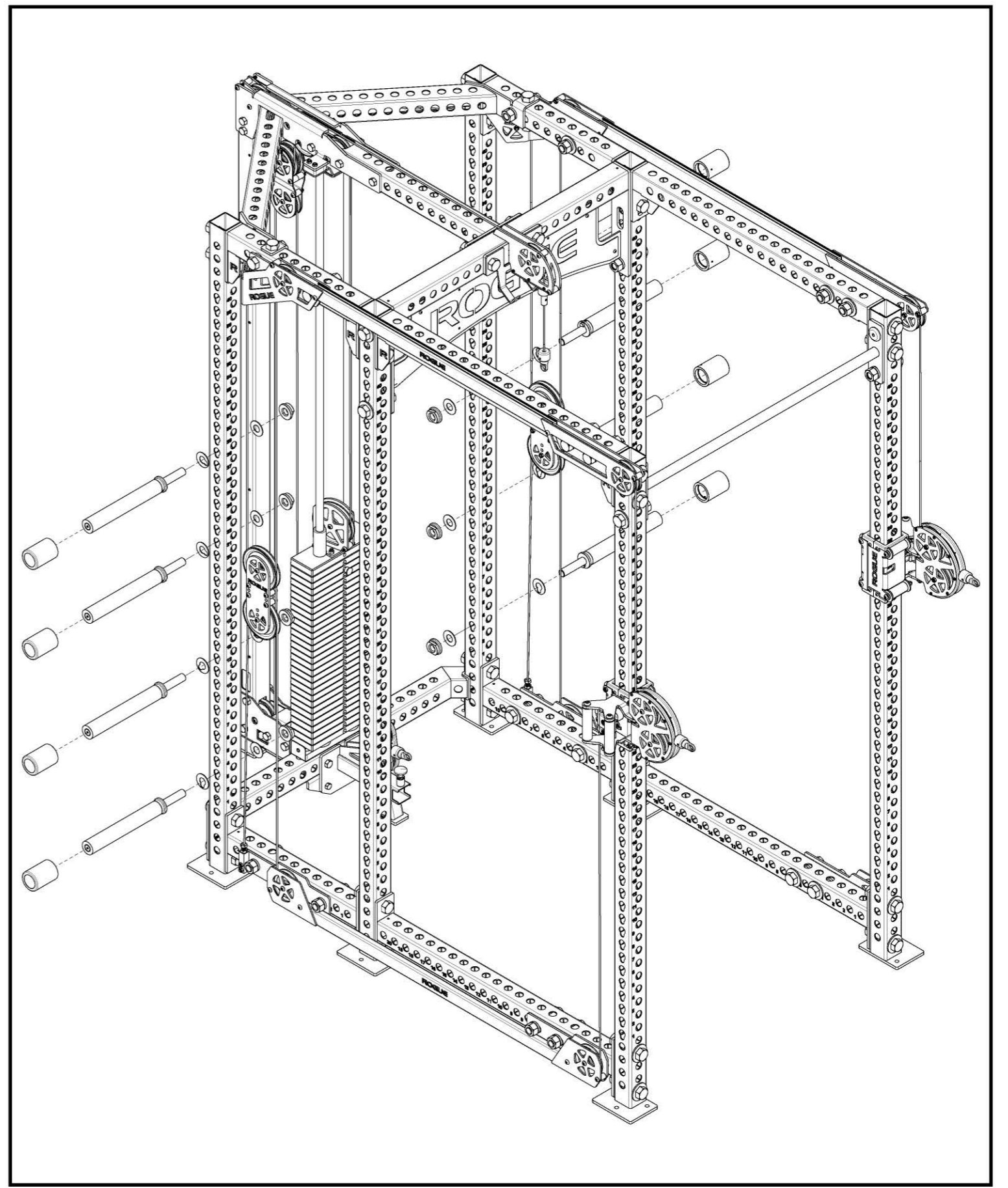

## STEP 36

### Tools Required:

- All
  - Tighten ALL loose hardware on the entire rack.
  - Starting with no weight selected on the Weight Stack, check cables by pulling on each clevis.
- If cables are too tight or loose, adjust accordingly by loosening or tightening the lower 1/2" Jam Nuts on Low Side Cables [55].

36-A

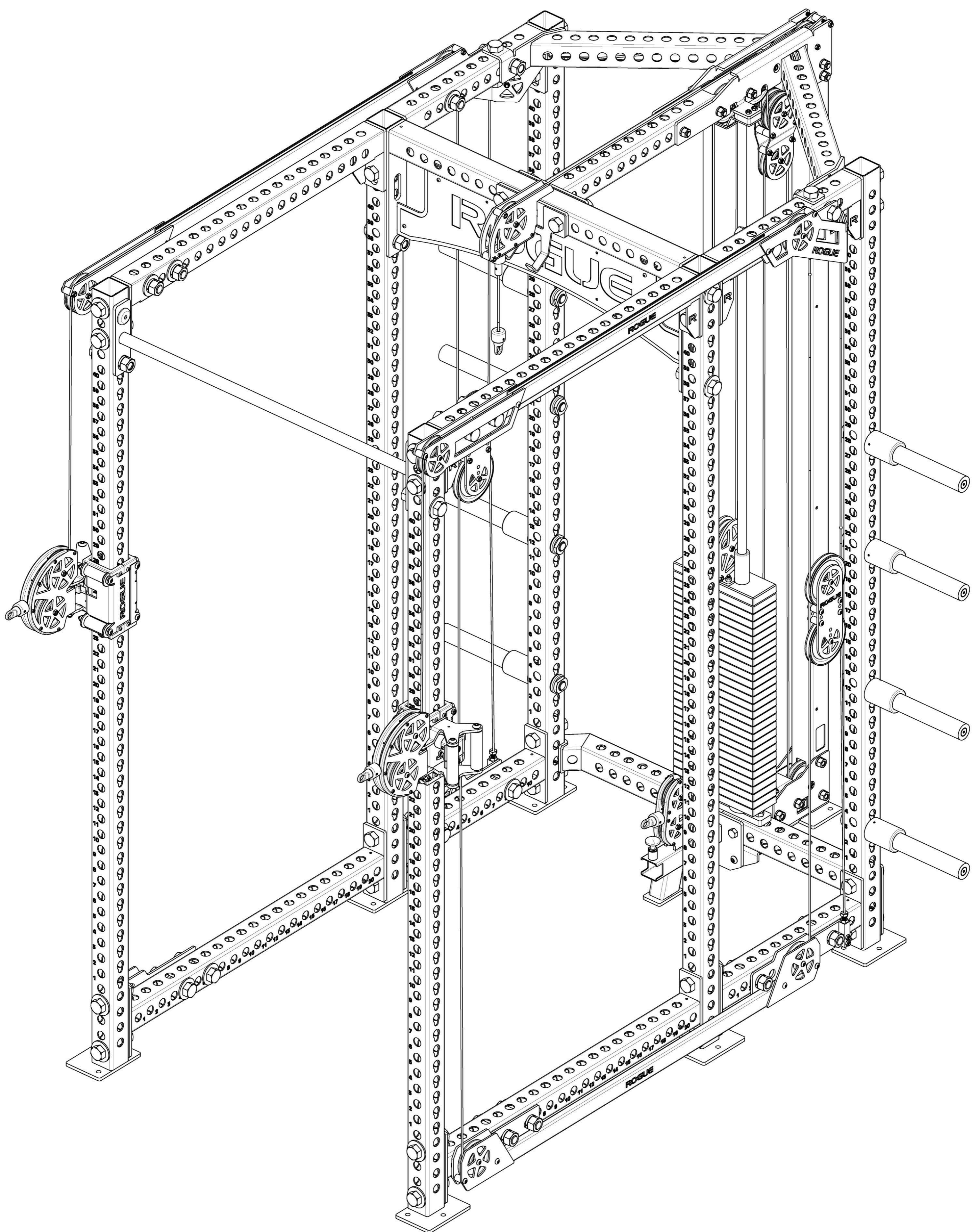

## STEP 37

- Apply the Weight Stack Number Labels [56] on the front of the Weight Stack Plates, approximately 3.5" from the edge of plate.
- Attach key ring on Selector Pin Lanyard [34] to front hole on pulley plate of the Weight Stack Stem [32]. Do not insert pin into Weight Stack Plate yet.
- Attach Single Handle Attachments [60] to Swivel Trolleys using included Carabiners.
- Attach Lat Bar [58] to Lat Pull down clevis attachment point.
- Re-insert the Footplate into Low Row Footplate Assembly [28] and attach Standard Grip Triangle [59] to clevis.

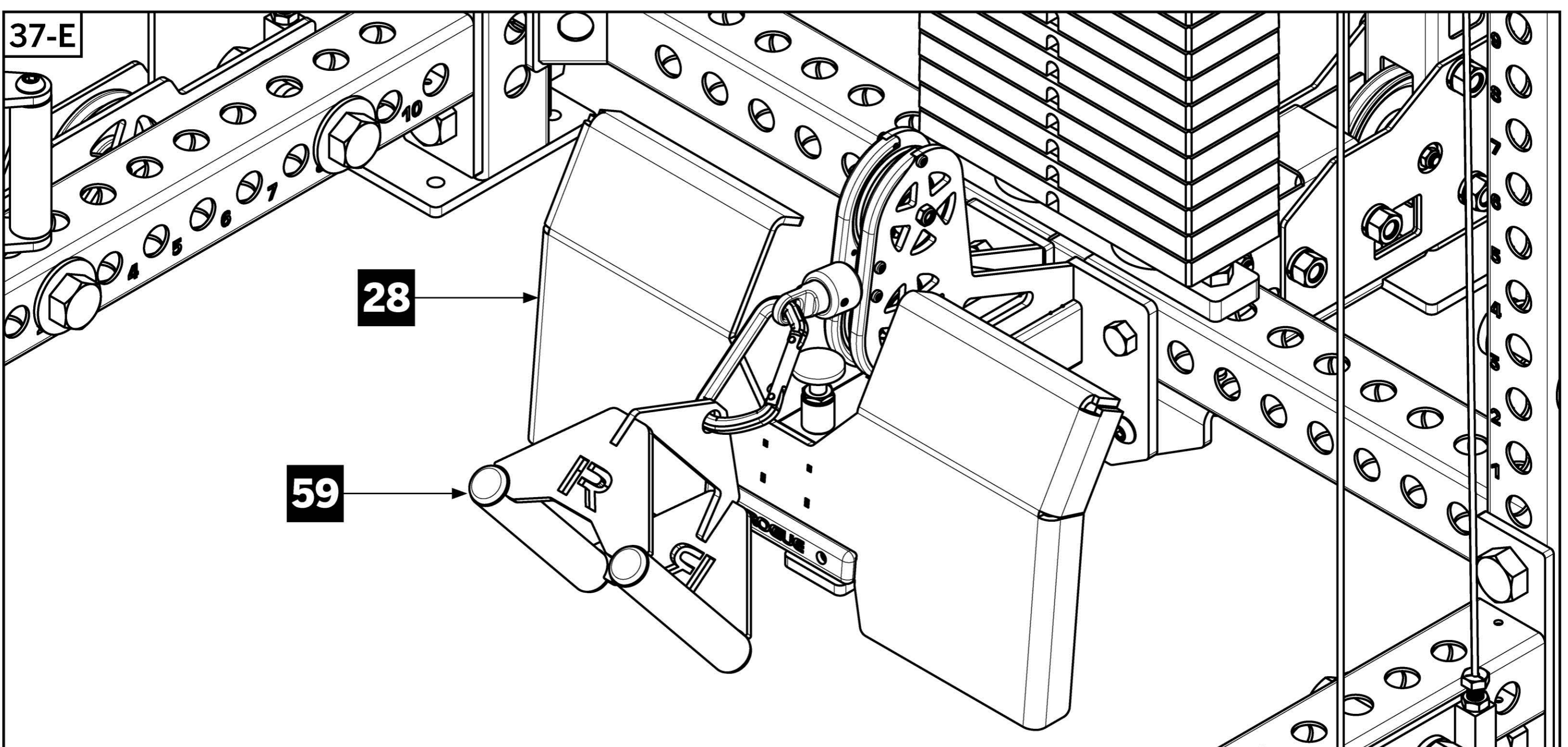
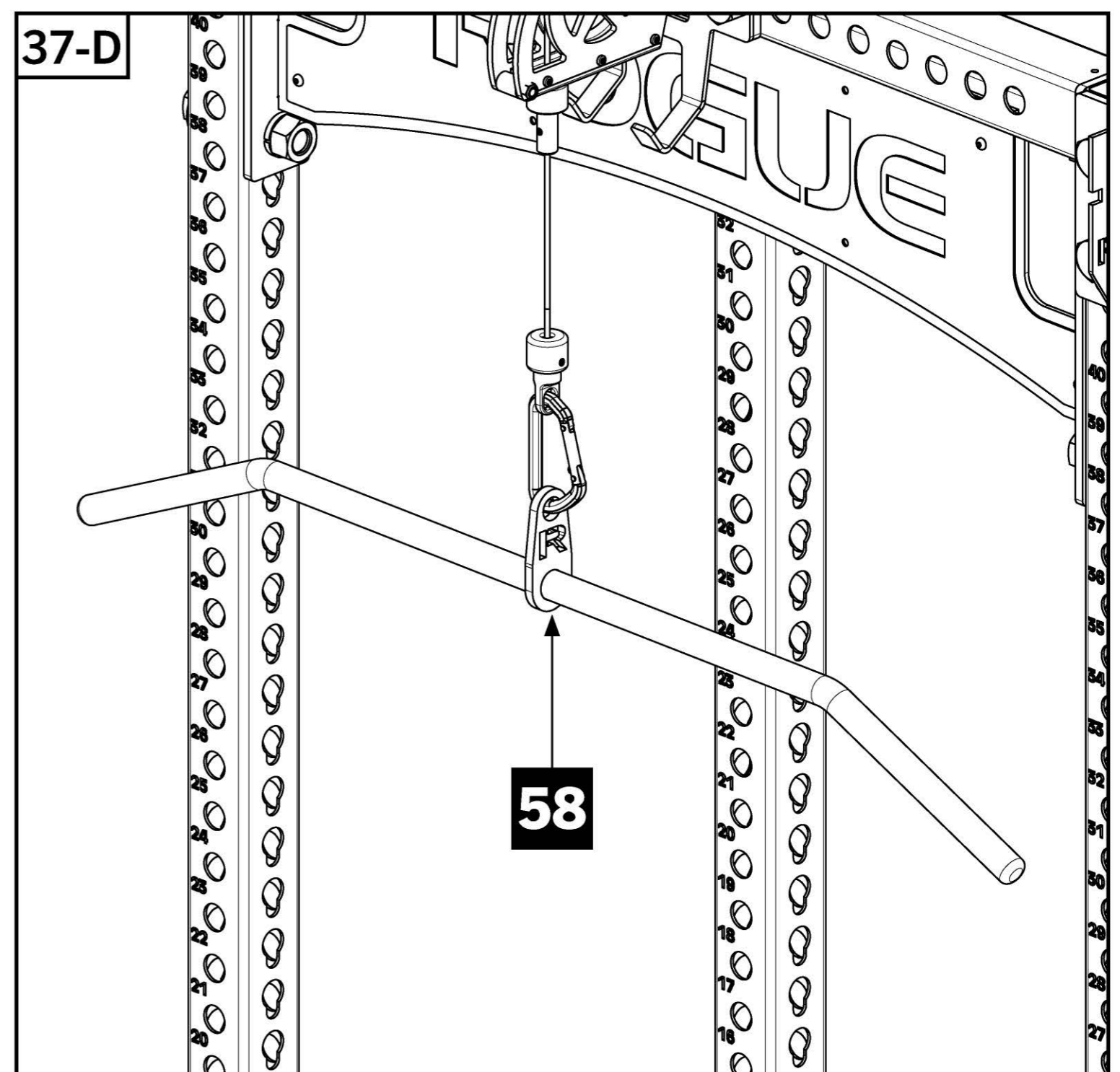
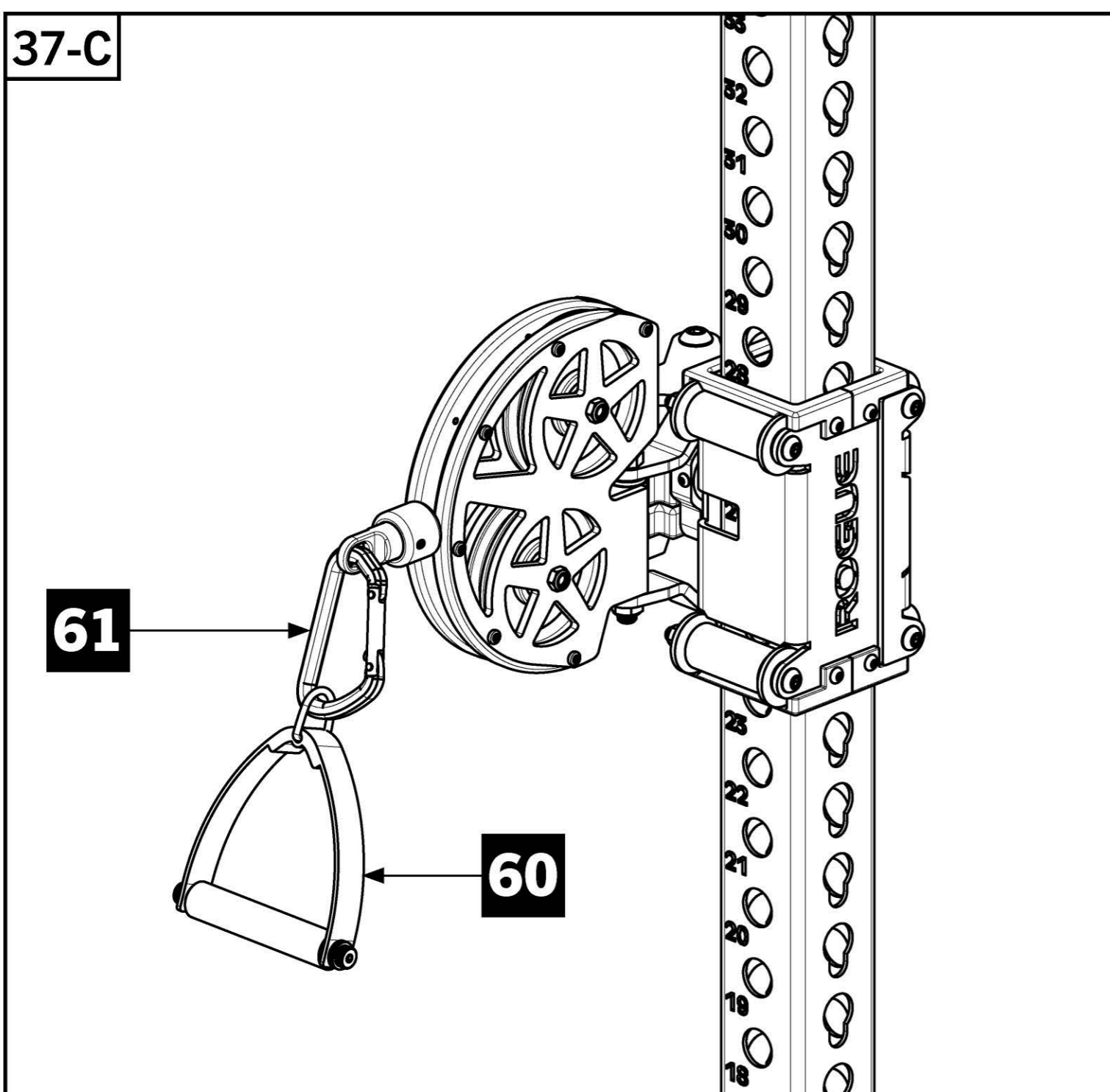
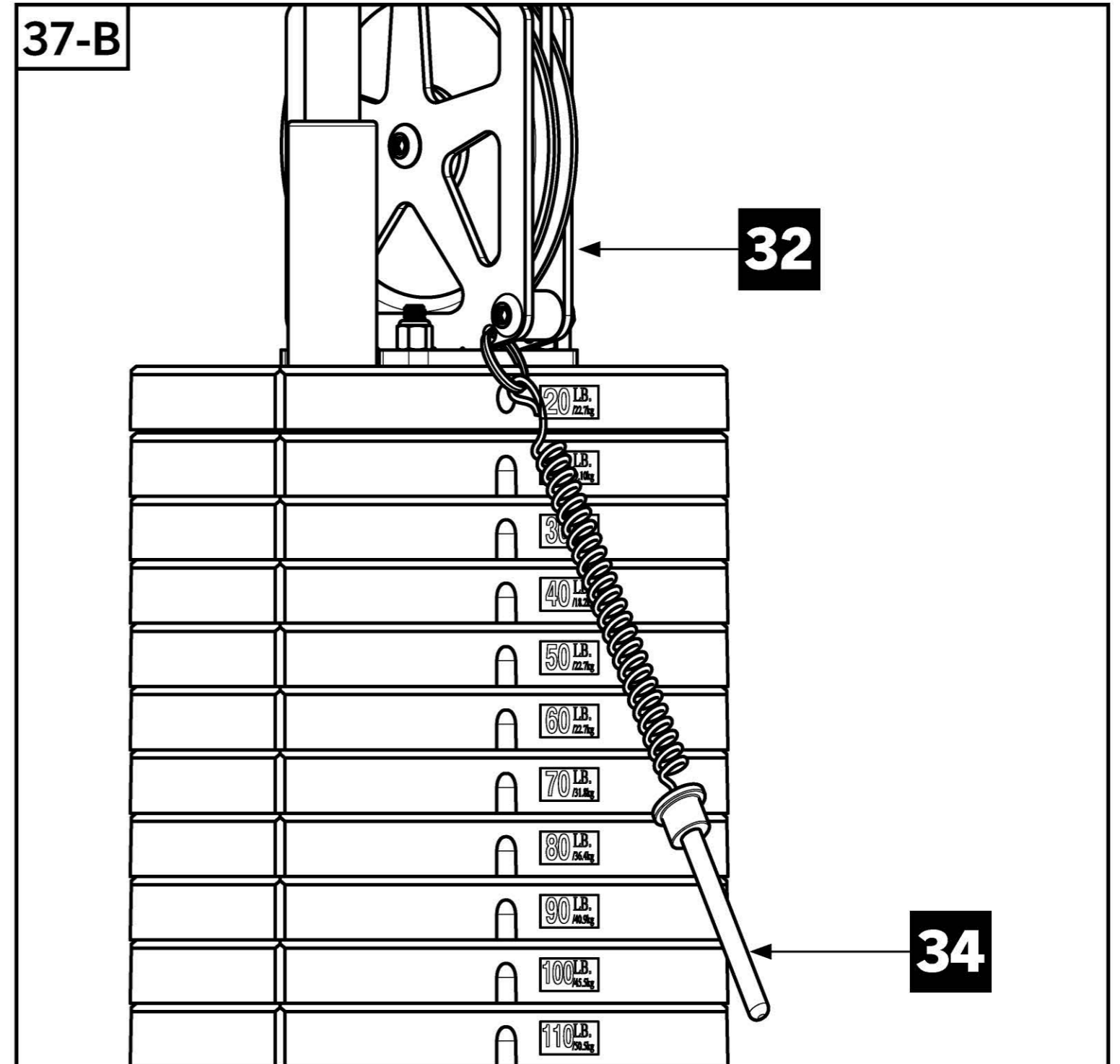
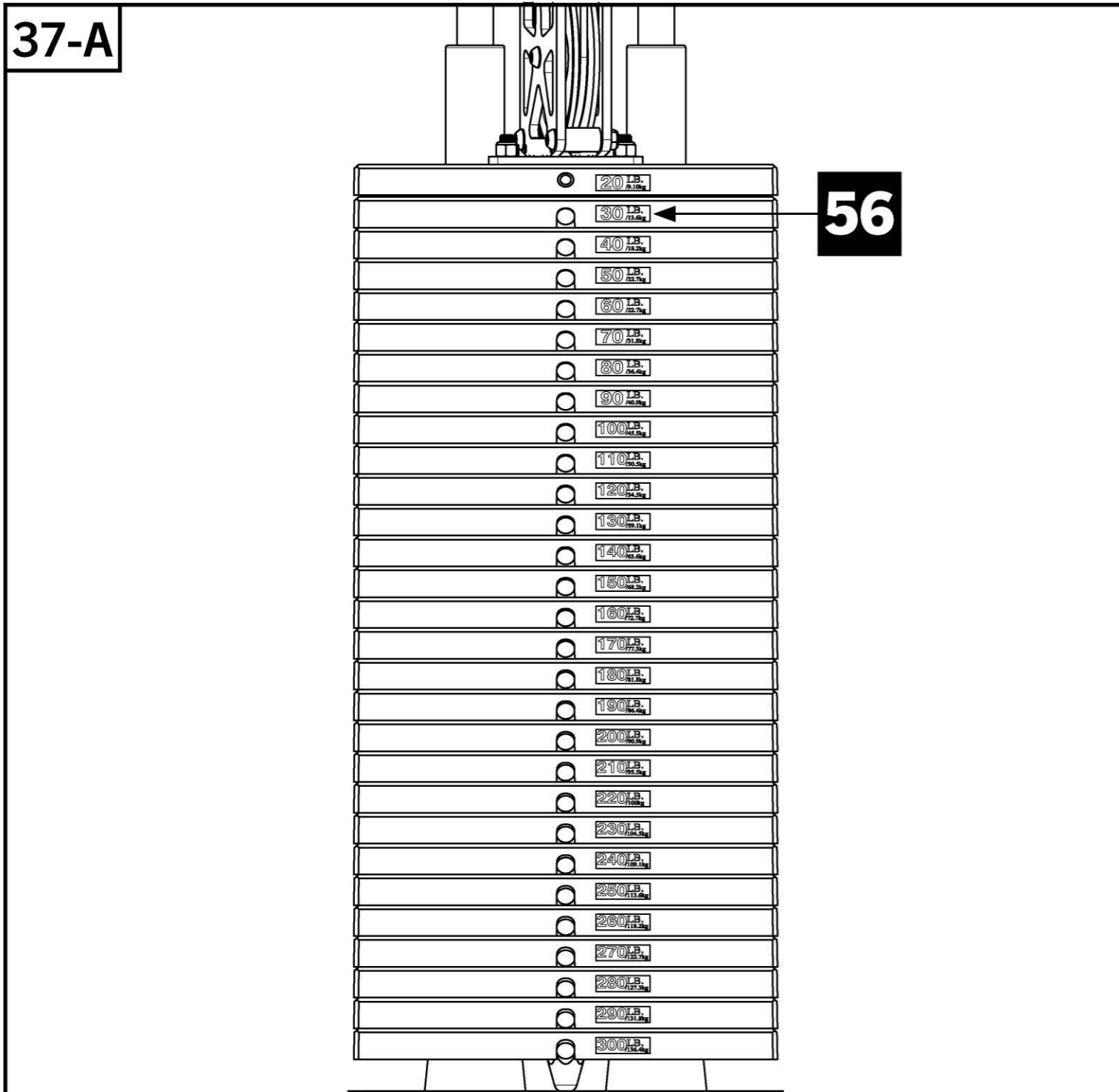

## STEP 38 (SHROUD ASSEMBLY)

- Align Weight Stack Shroud RH [79] and Weight Stack Shroud LH [80] with corresponding holes on Rear 3X3 Upright [17] and bolt Shrouds to Upright using 1/4" x 3-1/2" Button Head Screws [92] and 1/4" Nylock Nuts [94].
- Align top holes on Shrouds to the front side of Top Rear Angle Crossmembers and bolt together using 1/4" x 3-1/2" Button Head Screws and 1/4" Nylock Nuts.
- Align and bolt the bottom holes on Shrouds to the corresponding holes on Weight Stack Shroud Bottom Bracket [81] using 1/4" x 5/8" Button Head Screws [93].

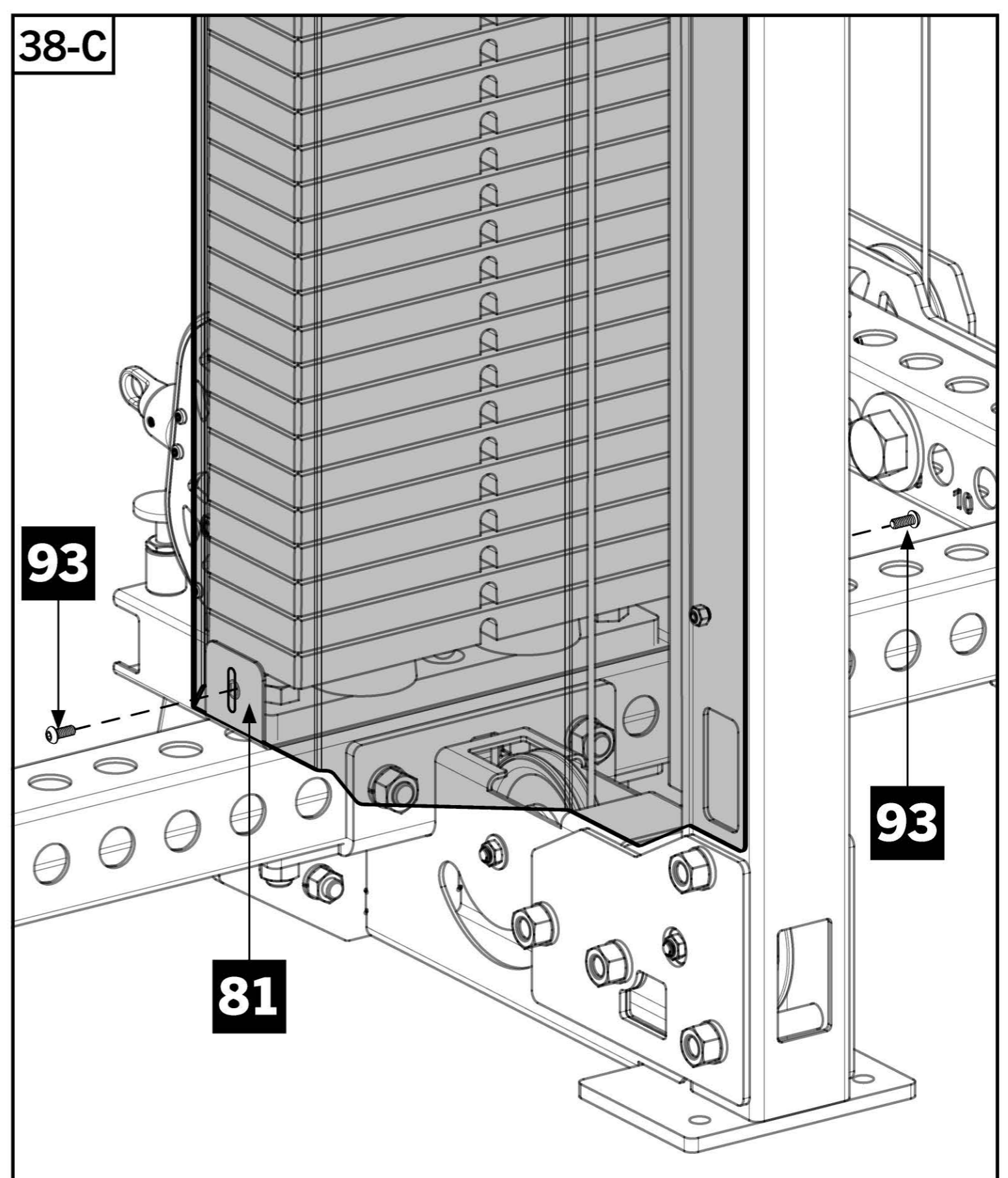
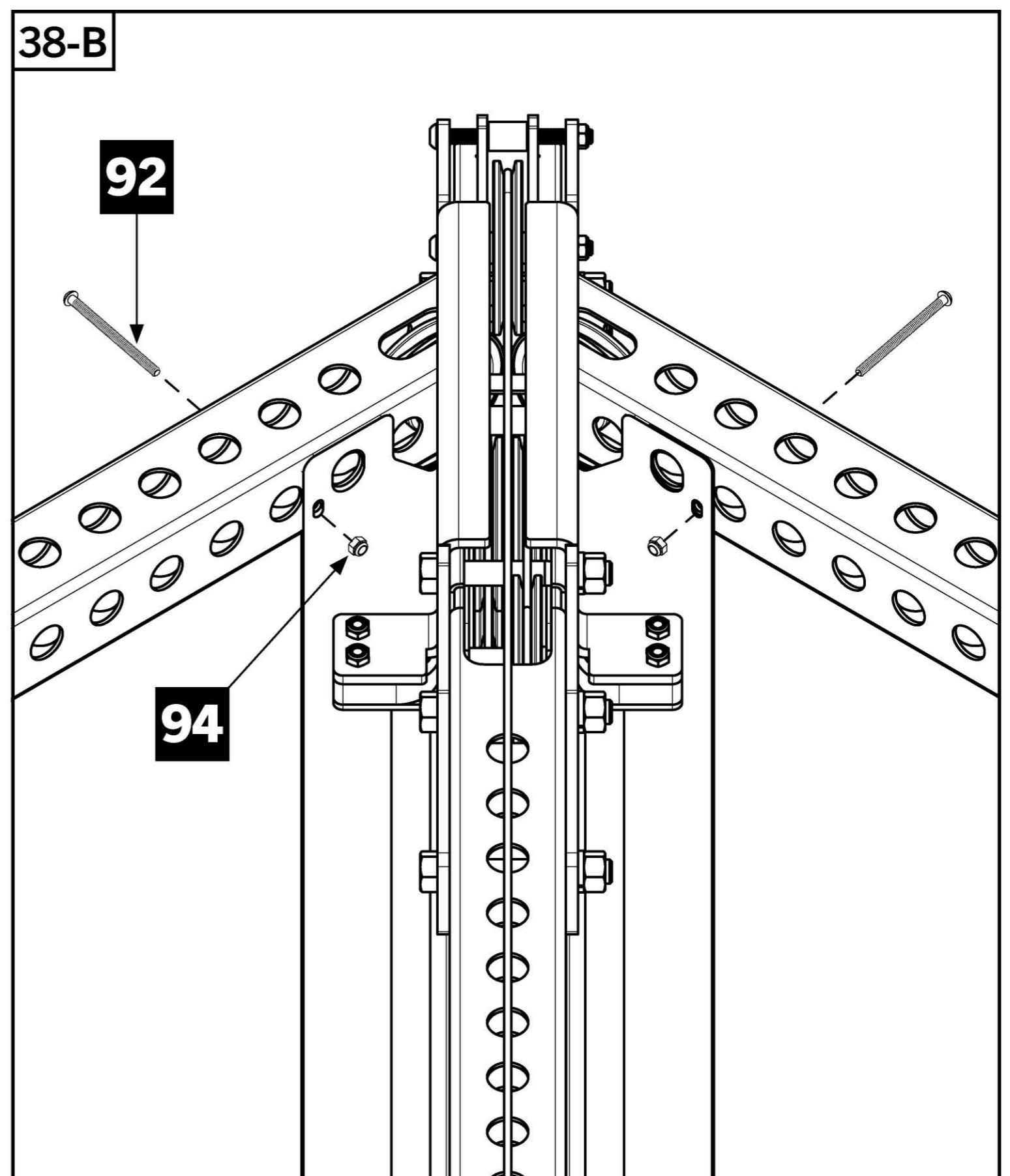
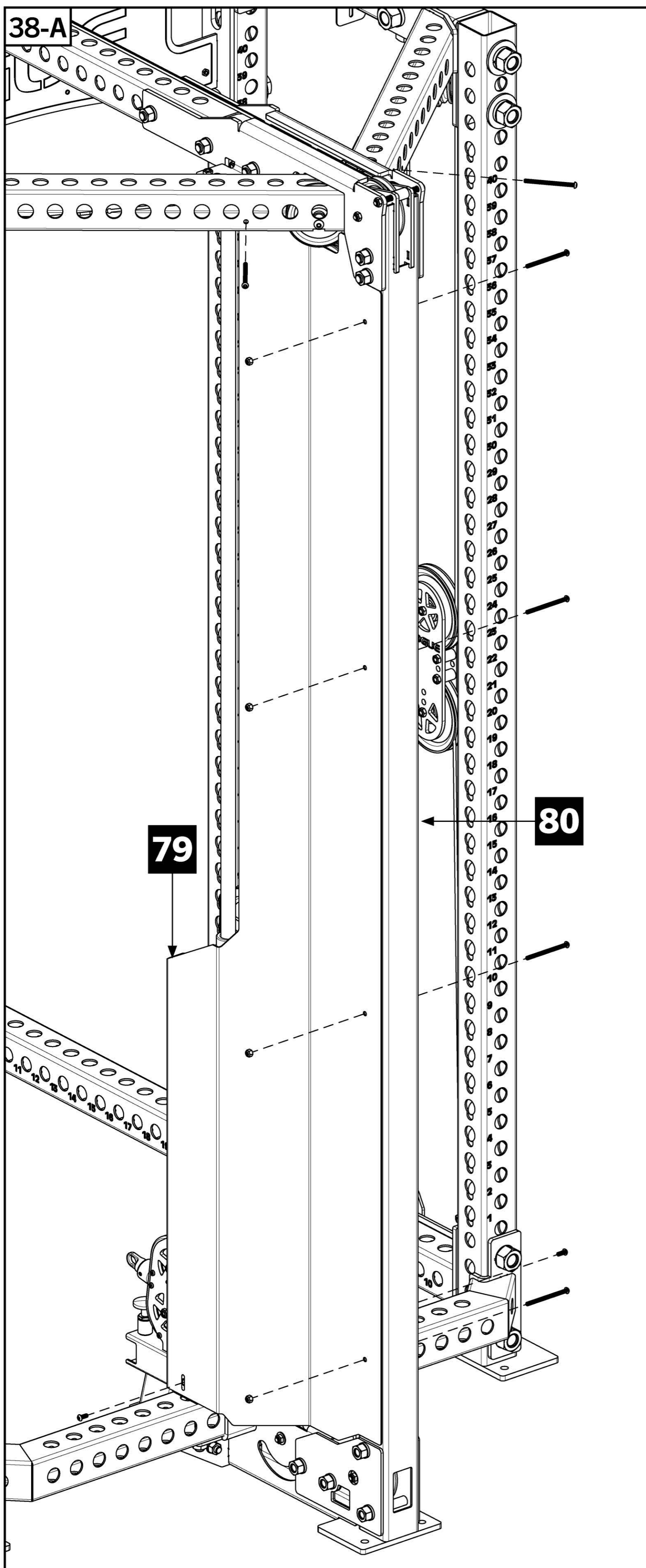
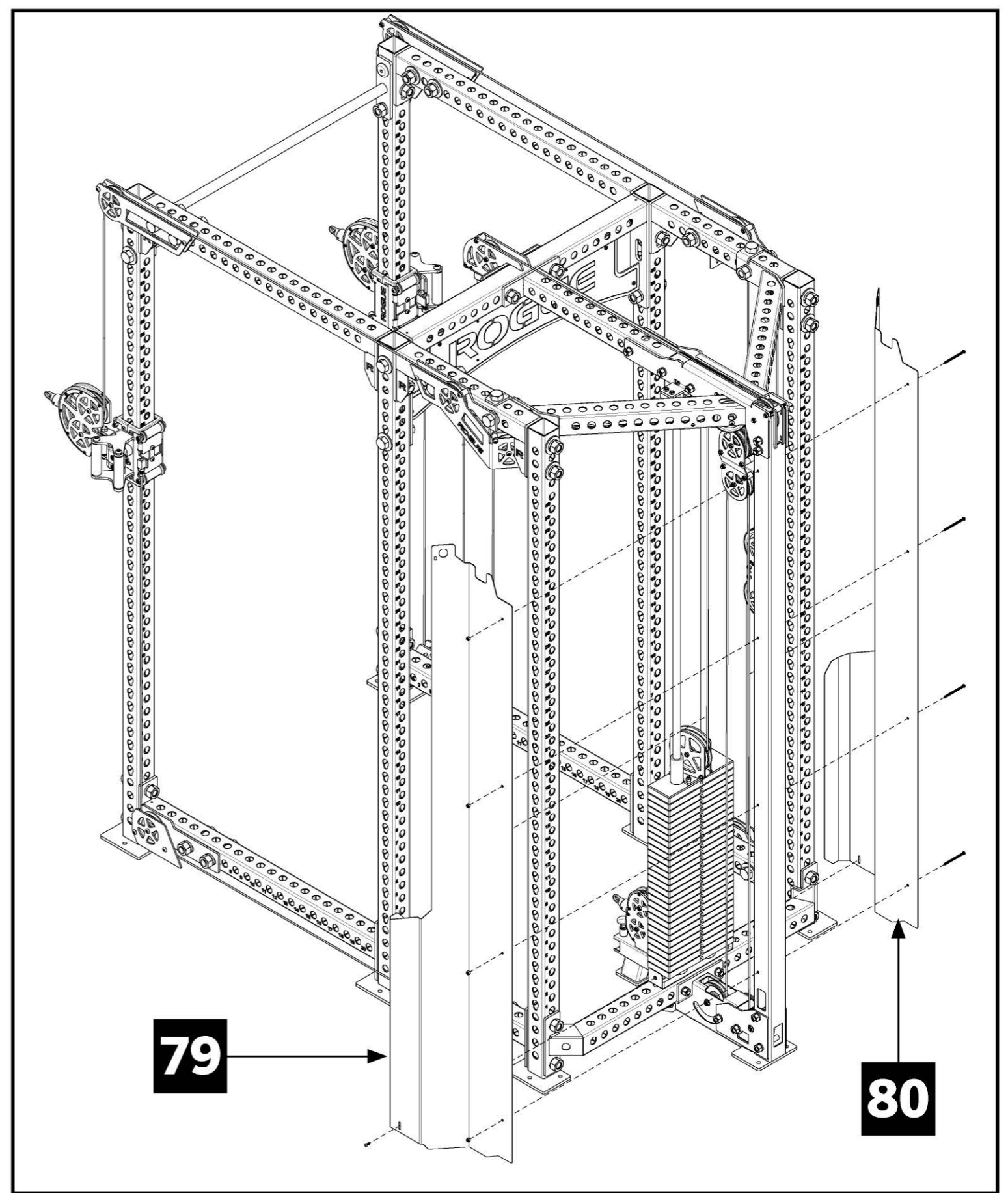

## STEP 39 (SHROUD ASSEMBLY)

- Bolt Side Shroud Bottom Brackets [87] vertically to 24" Rear Low Crossmember [5] in locations shown using 1" x 4-1/2" Hex Bolts [88], 1" Flat Washers [89], 1" Lock Washers [90], and 1" Hex Nuts [91].
- Assemble Side Shroud -RH [82] and -LH [83] on rear uprights of rack using included 1" hardware through the highest and lowest 1" holes on Side Shrouds.

### Note:

- Leave the 1" Hex Nuts shown in 39-B and 39-C very loose until Storage Panels are assembled on the next step.

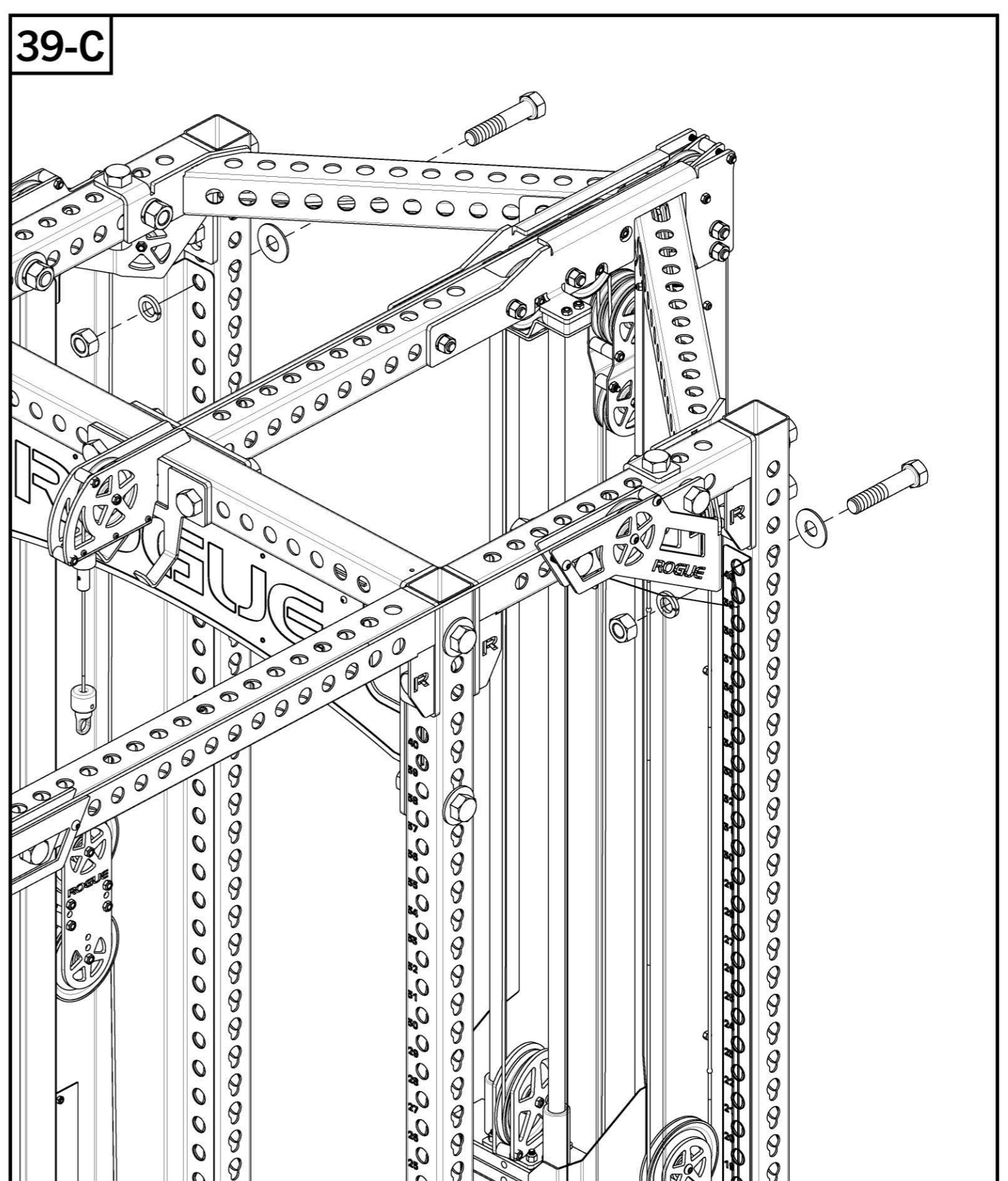
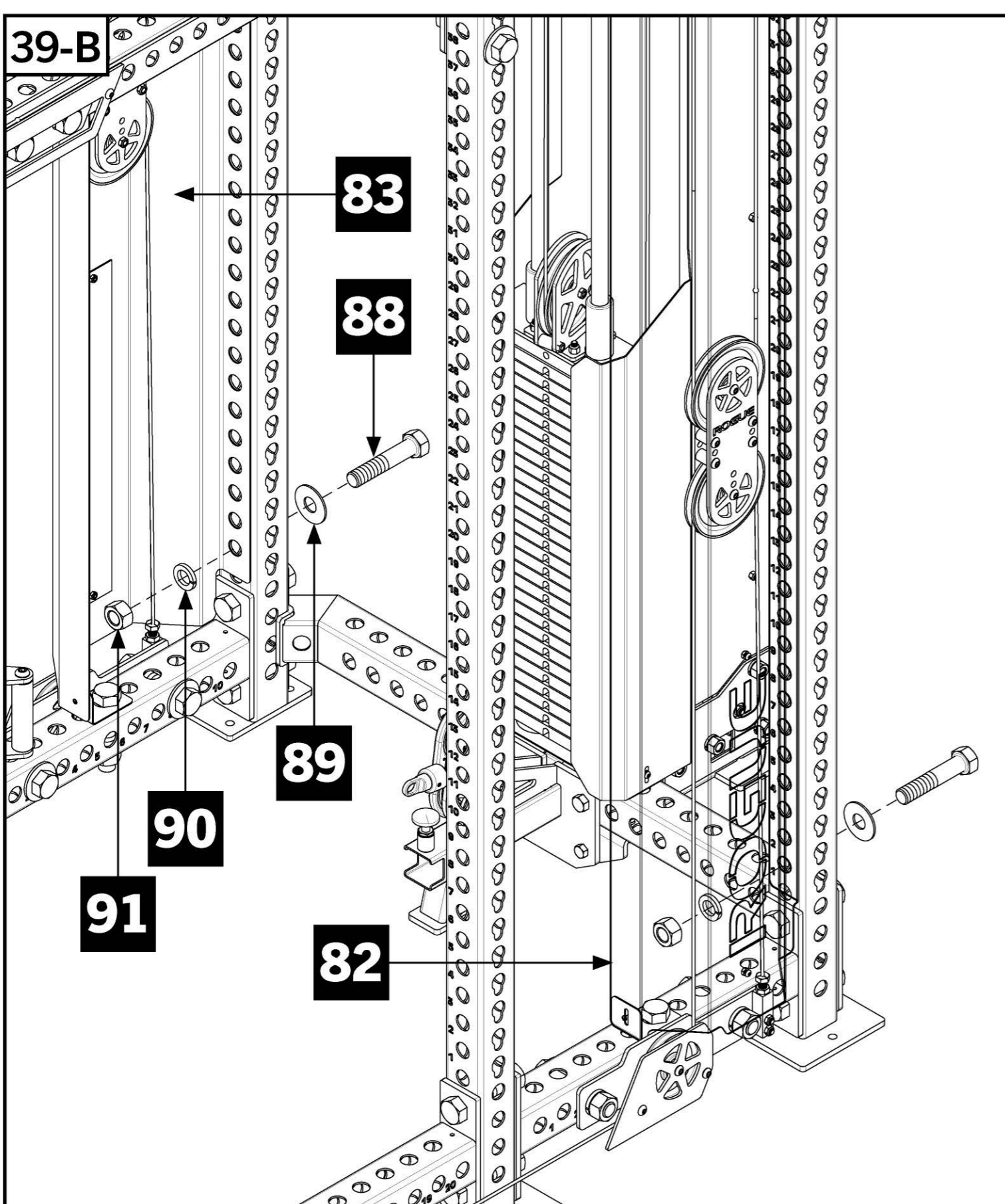
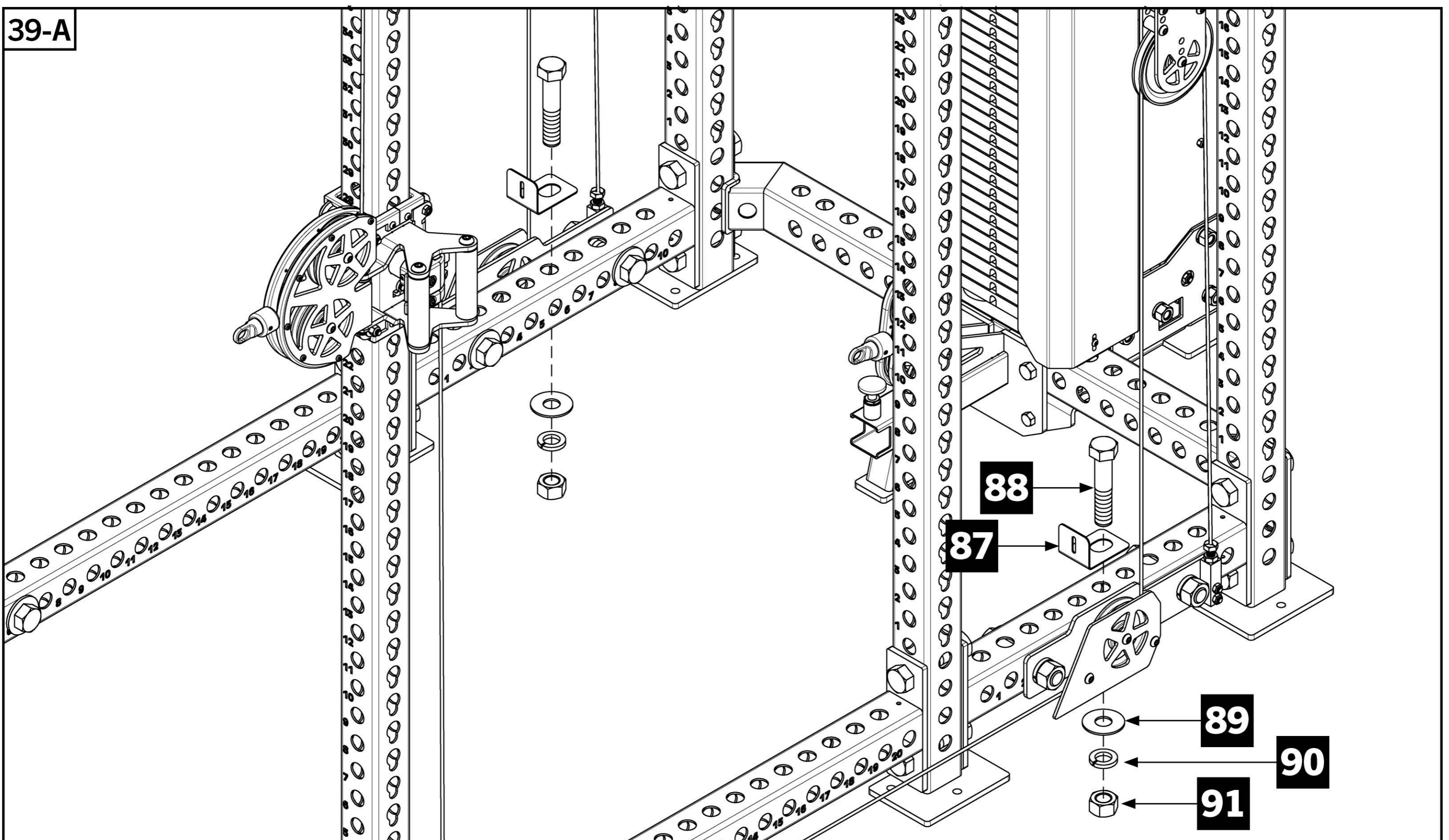
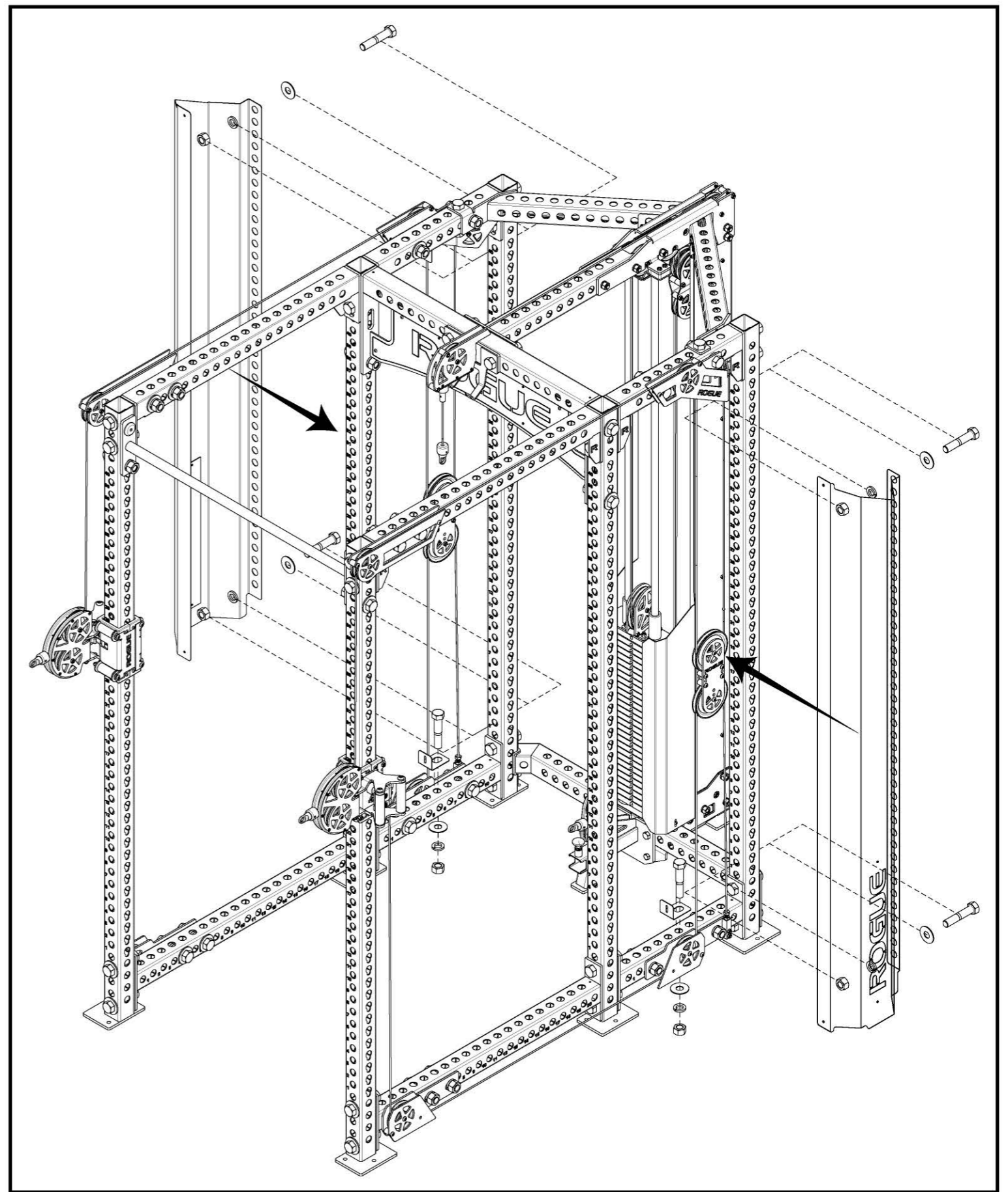

# STEP 40 (SHROUD ASSEMBLY)

## Tools Required:

- 1-1/2" Wrench, 5/32" Allen Key, 7/16" Wrench
- Attach rear top and bottom holes on Storage Panels [84],[85] to horizontal 1" hardware installed on previous step, and align 1/4" holes on front with 1/4" holes on Side Shrouds and Shroud Brackets.
- Bolt both Side Shrouds and Storage Panels to Bottom Brackets using four 1/4" x 5/8" Button Head Screws [93] and four 1/4" Thin Nylock Nuts [95].
- Fully tighten all Shroud Kit hardware.

## Note:

- Only the LH Storage Panel shown below. Repeat steps below to assemble the RH Storage Panel onto Side Shroud RH.

