

ROGUE® ECHO ROWER

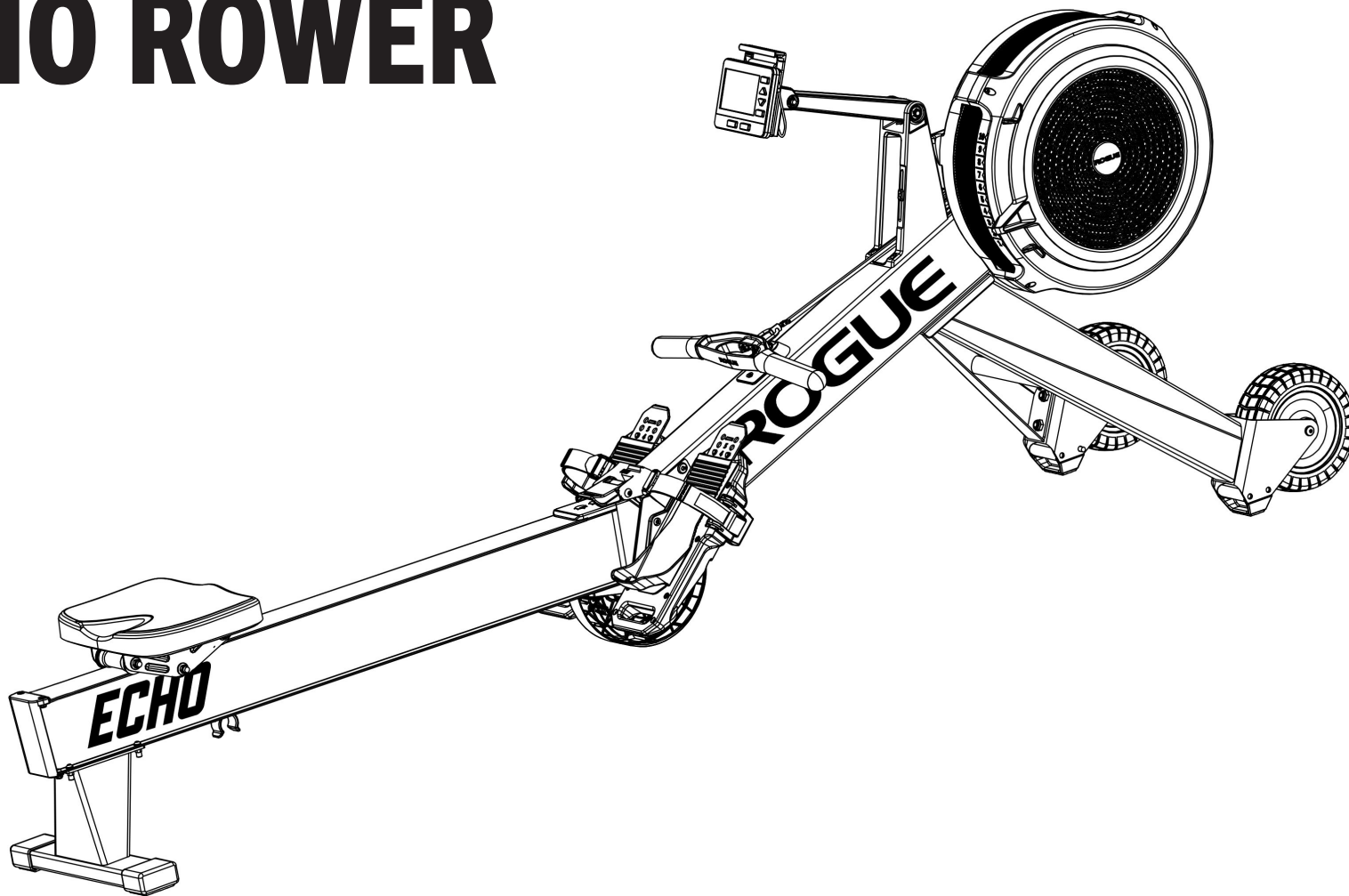





IMPORTANT SAFETY INFORMATION

WARNING:

MISUSE OF THIS CAN RESULT IN SEVERE INJURY.

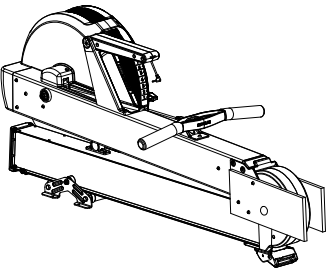
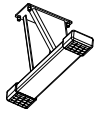
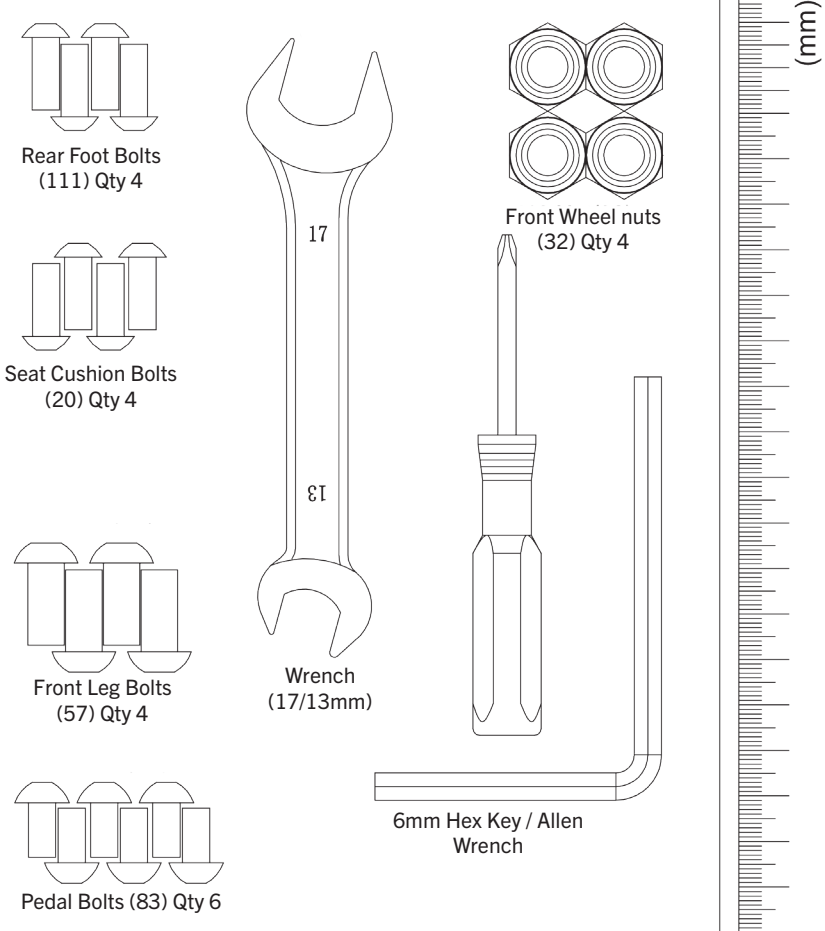
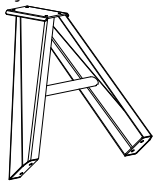
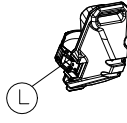
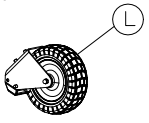
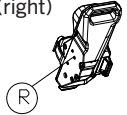
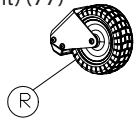
Both Rogue Fitness and buyer disclaim any express or implied warranty, including, without limitation, warranties or merchantability and/or fitness for a particular purpose with respect to the equipment. Buyer assumes all liability to use of equipment.

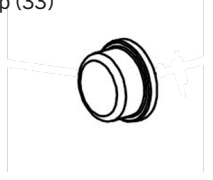
PARTS AND TOOLS USED

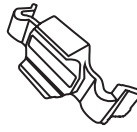
<p>Rower Main Frame (80)</p> 	<p>Rear Foot (108)</p> 	 <p>Rear Foot Bolts (111) Qty 4</p> <p>Seat Cushion Bolts (20) Qty 4</p> <p>Front Leg Bolts (57) Qty 4</p> <p>Pedal Bolts (83) Qty 6</p> <p>Front Wheel nuts (32) Qty 4</p> <p>Wrench (17/13mm)</p> <p>6mm Hex Key / Allen Wrench</p> <p>T27 Torx Wrench</p> <p>(mm)</p>
<p>Front Foot Assembly (56)</p> 	<p>Pedal (left) (95)</p> 	
<p>Front Wheel (left) (78)</p> 	<p>Pedal (right) (90)</p> 	
<p>Front Wheel (right) (77)</p> 	<p>Seat (123)</p> 	
<p>End Cap (33)</p> 	<p>Console (74)</p>  <p>Yellow Tools/fastener card (142)</p>  <p>Seat spacer (119)</p> 	

STEP 1

- TAKE OUT THE FRAME (80)
- USE THE T27 TORX WRENCH TO REMOVE THE 6 SCREWS ON THE PROTECTION BOARD. THESE ARE NO LONGER REQUIRED AND CAN BE SAFELY DISPOSED

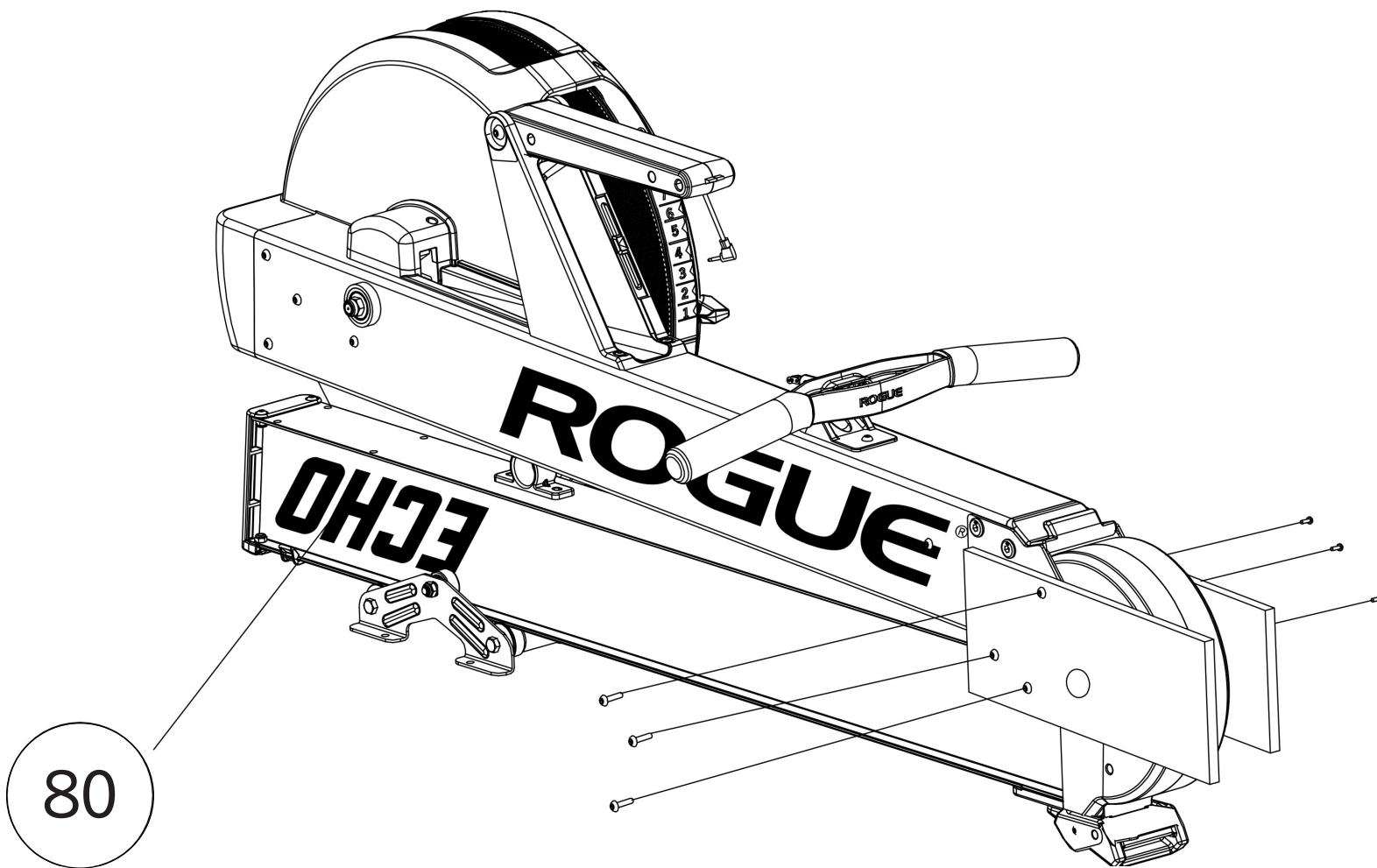

STEP 2

- ASSEMBLE THE END CAP (33) ONTO THE FRAME (80)

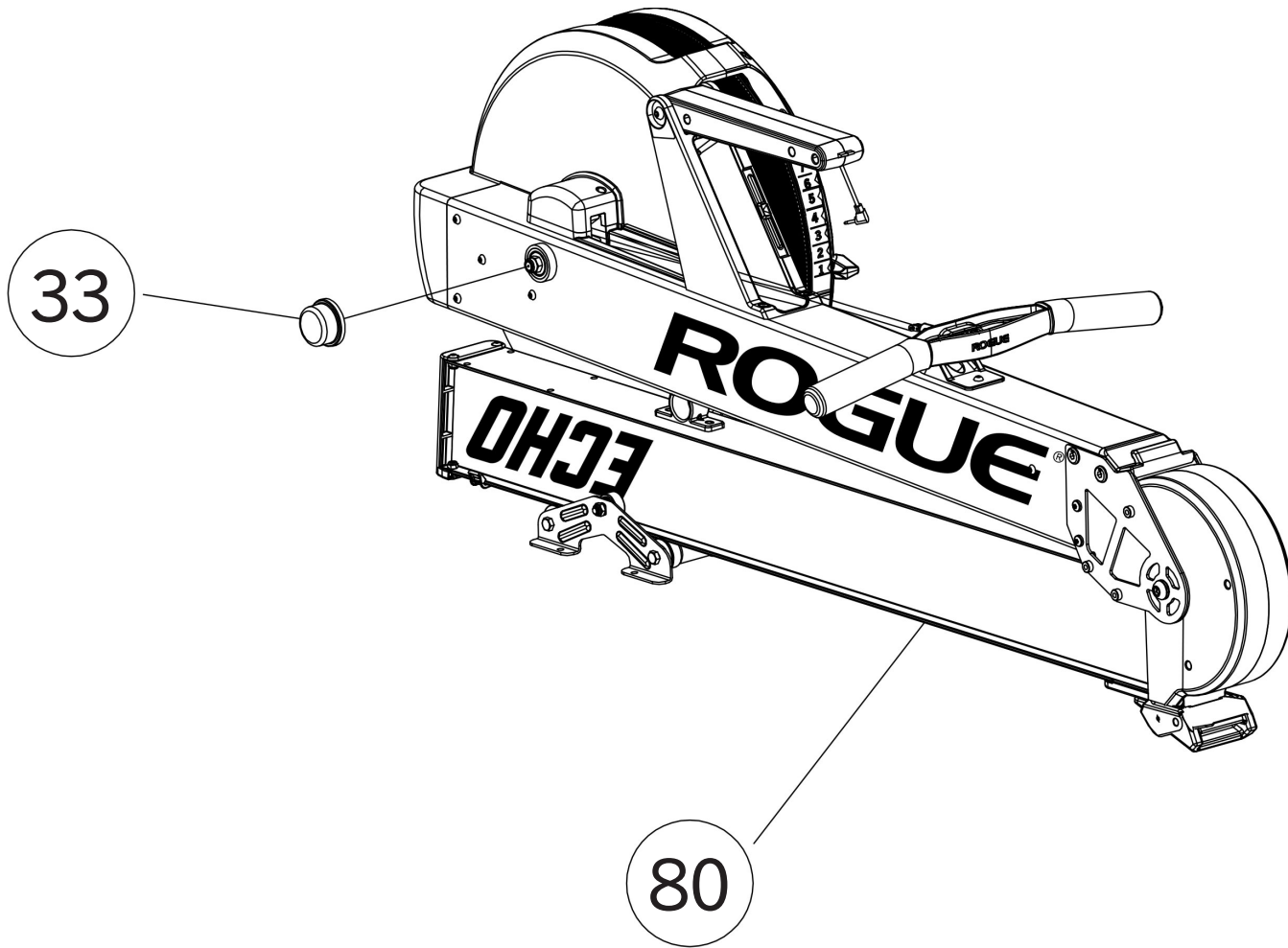

STEP 3

- FIX THE TURF TIRE WHEELS (L) AND (R) ONTO THE FRONT FOOT TUBE ASSEMBLY (56) USING THE FOUR FRONT WHEEL NUTS (32) AND THE 17MM WRENCH

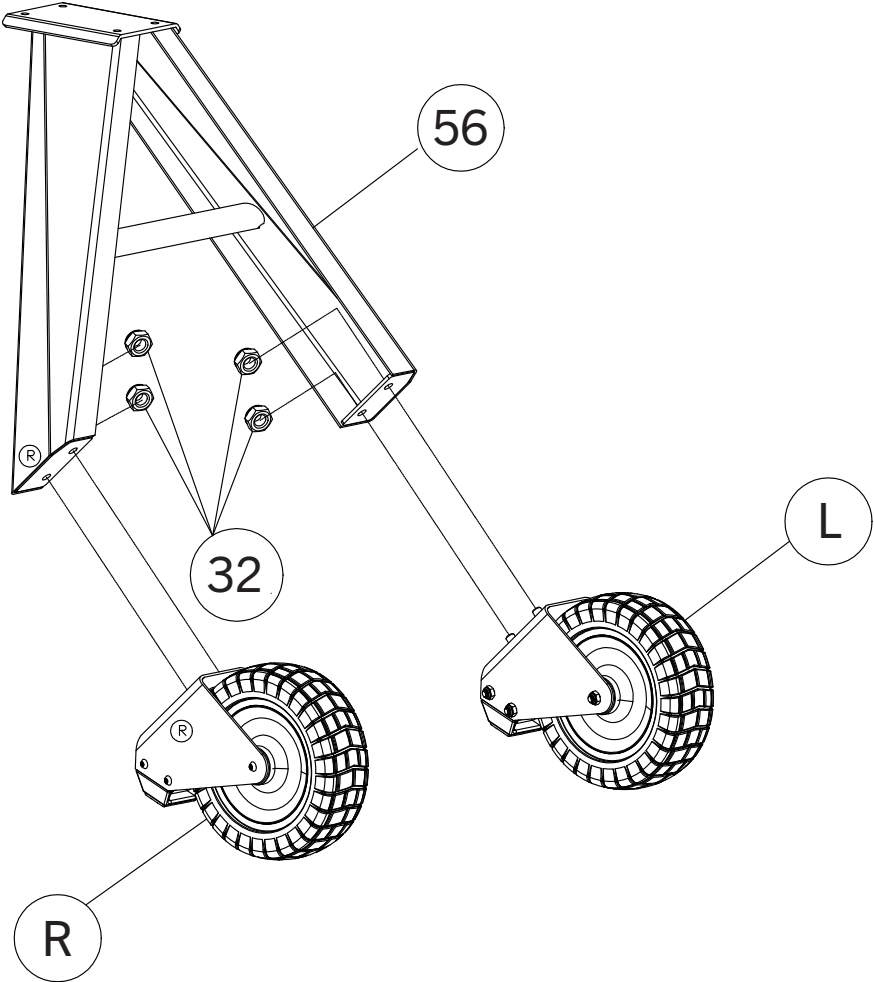

STEP 4-1

- IT IS RECOMMENDED TO USE TWO PEOPLE FOR THIS STEP
- STAND THE FRAME VERTICALLY THEN CAREFULLY RELEASE THE LOCKING CLIP AND SPREAD THE ENDS OF THE ROWER MAIN FRAME APART BY 12"/30CM
- INSERT THE ROUND CROSS BAR OF THE FRONT LEG ASSEMBLY (56) INTO THE PLASTIC RECEIVER BASE ON THE ROWER MAIN FRAME (80) SLOWLY CLOSE THE ROWER BACK UP UNTIL THE BOLT HOLES OF THE FRONT LEG ASSEMBLY ALIGN WITH THE HOLES IN THE MAIN FRAME (UNDERNEATH THE "R" OF ROGUE)

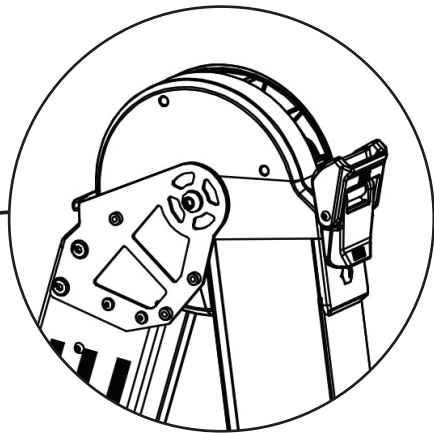
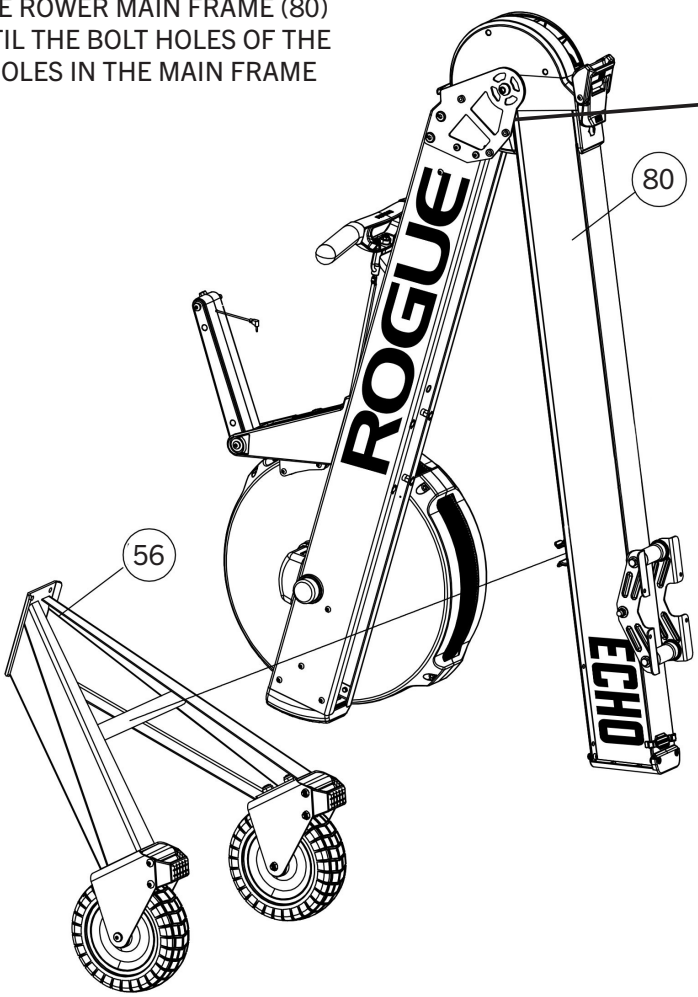

CAUTION
PINCH POINT WARNING

STEP 4-2

- STAND THE FRAME VERTICALLY
- USE THE 6MM HEX KEY TO SECURE THE FRONT LEG ASSEMBLY (56) TO THE MAIN FRAME (80) WITH THE FOUR FRONT LEG BOLTS (PART 57)

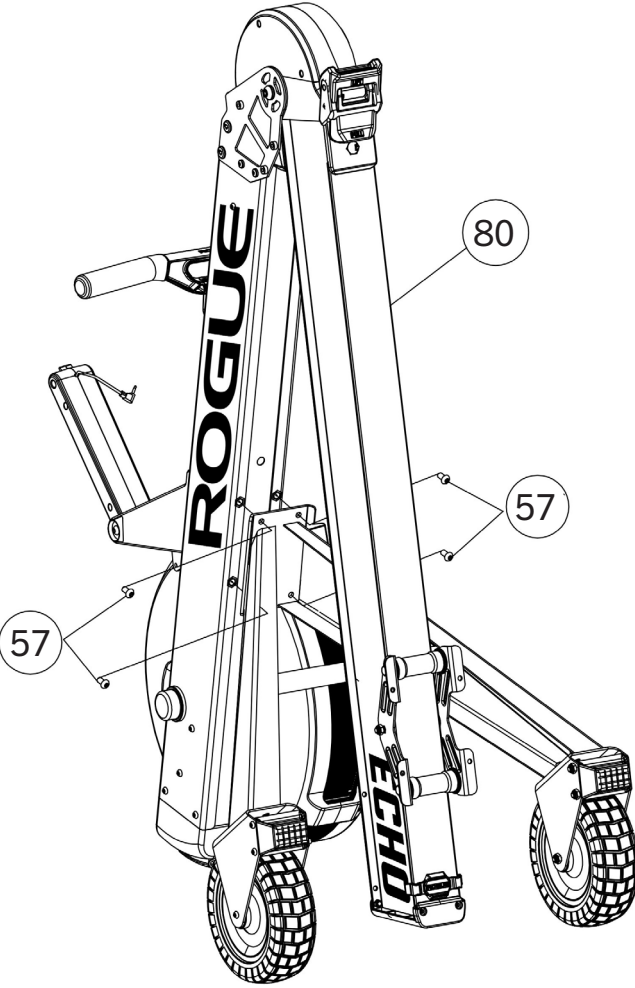

STEP 5

- USE THE T27 TORX WRENCH TO SECURE THE LEFT (95) AND RIGHT (90) PEDALS TO THE ROWER MAIN FRAME (80) WITH 3 OF THE FOOT PEDAL BOLTS (83) ON EACH SIDE

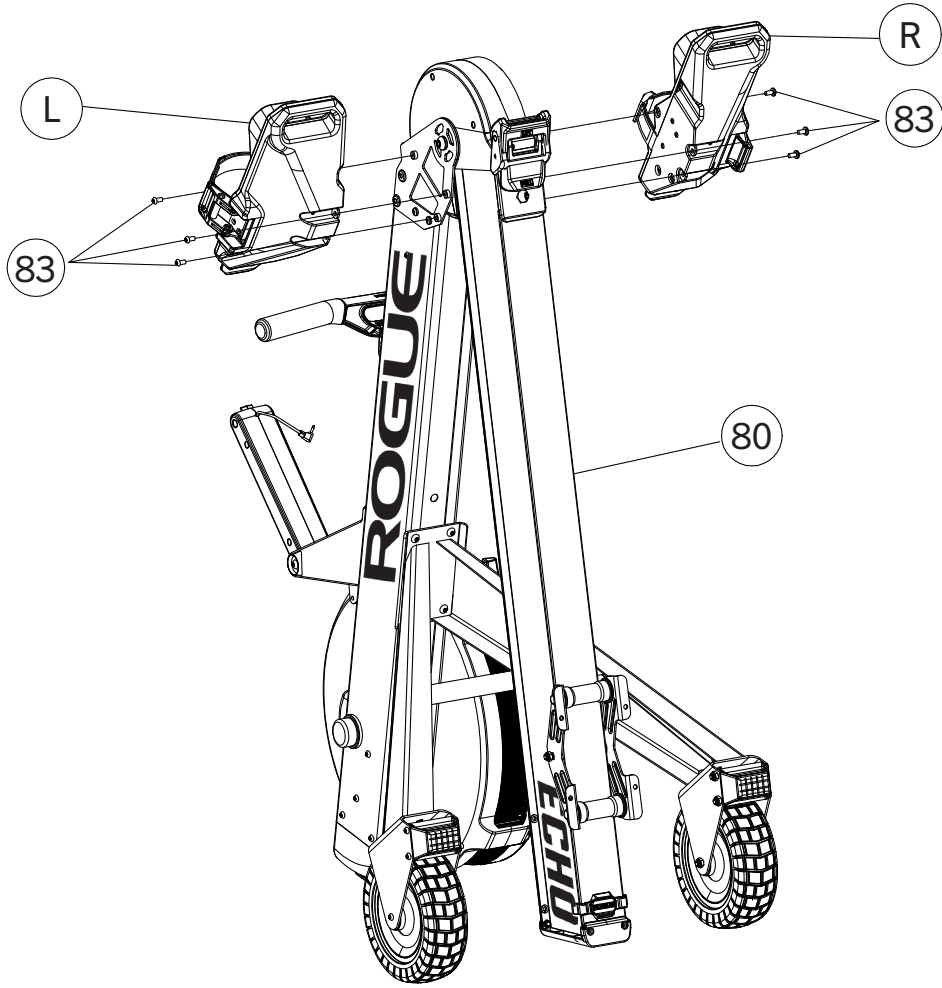

STEP 6

- SECURE THE REAR FOOT ASSEMBLY (108) TO THE ROWER MAIN FRAME (80) WITH THE FOUR REAR FOOT BOLTS (111) USING THE T27 TORX WRENCH

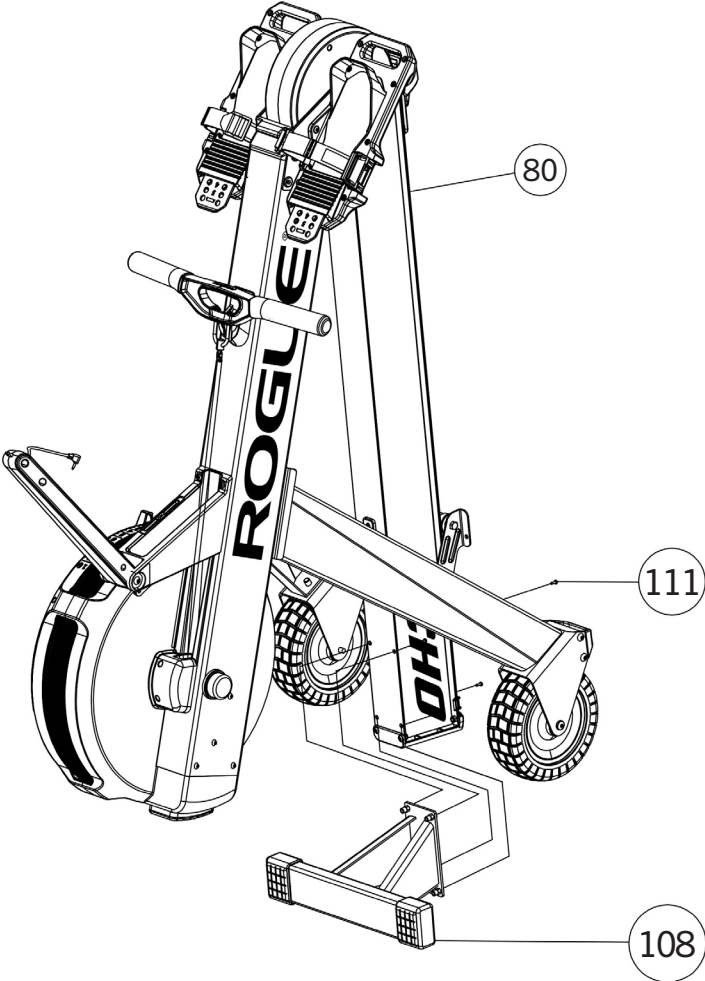

STEP 7

- SECURE THE SEAT CUSHION (123) TO THE SEAT BRACKET ASSEMBLY ON THE ROVER MAIN FRAME (80) WITH THE FOUR SEAT CUSHION BOLTS (PART 20) USING THE T27 TORX WRENCH
- SEE ORIENTATION IN IMAGE FOR CORRECT SEAT ALIGNMENT (123)

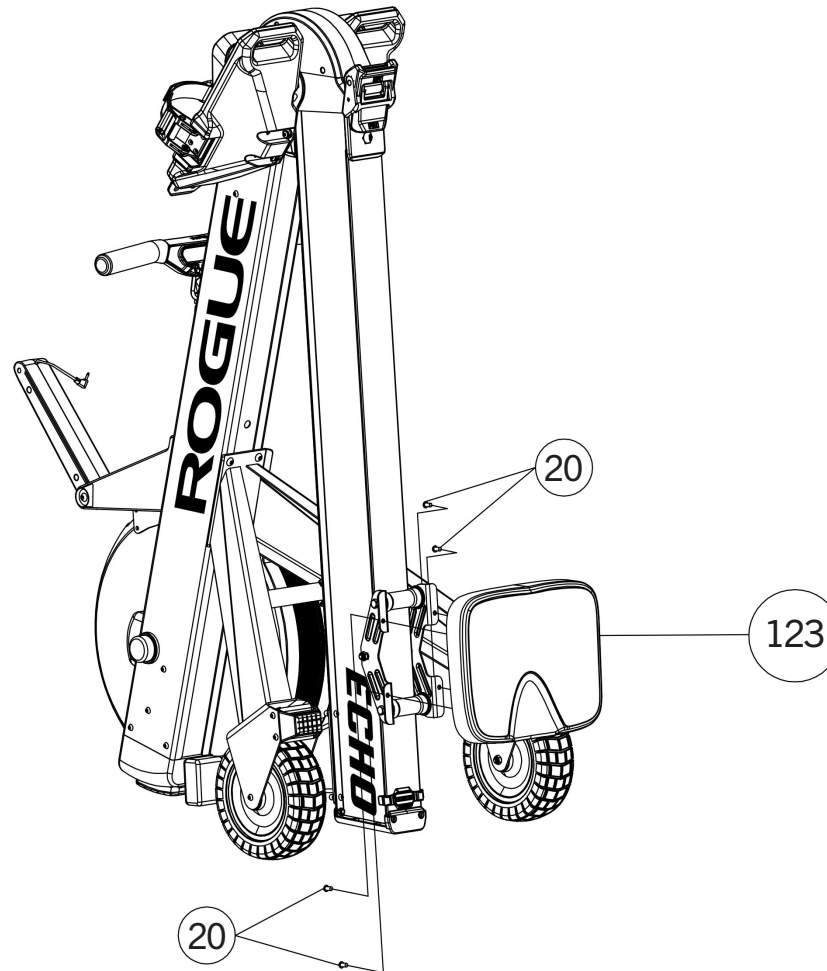

STEP 8

- CAREFULLY UNFOLD THE WHOLE UNIT BY PLACING A FOOT ON ONE OF THE REAR TIRES, RELEASING THE HINGE LATCH AND SLOWLY OPENING THE ROWER OUT INTO A HORIZONTAL POSITION
- AS YOU UNFOLD, GUIDE SEAT FORWARD TO ENSURE IT DOES NOT FALL
- PLACE HORIZONTALLY

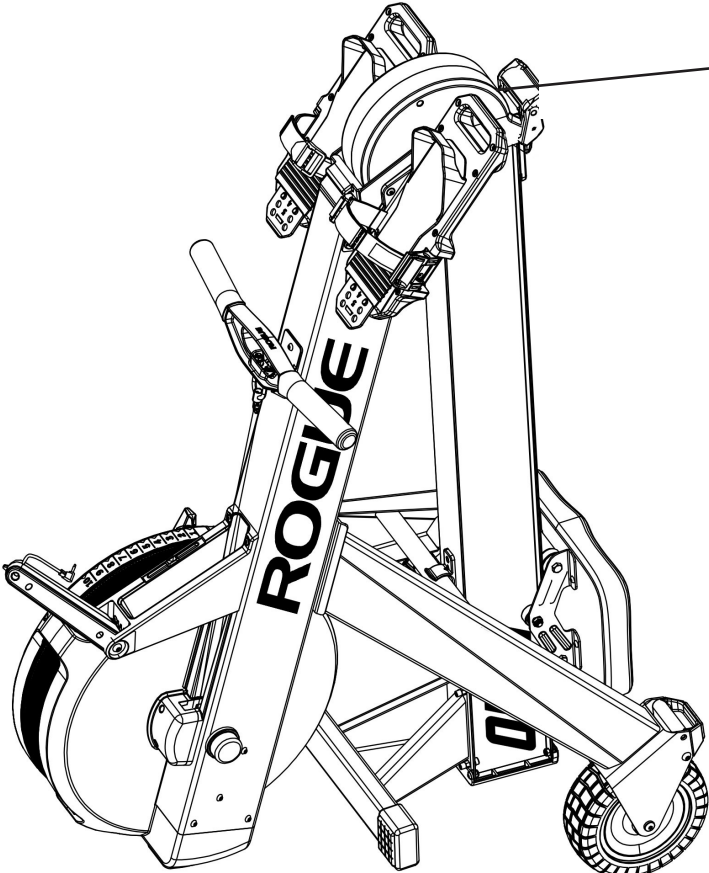

⚠ CAUTION
PINCH POINT WARNING
KEEP YOUR HANDS CLEAR
OF THE HINGE- DO NOT PUT
FINGERS ON THE LATCH WHEN
CLOSING

STEP 9

- TO SECURELY LOCK THE ROWER MAIN FRAME (80) LIFT THE LATCH HANDLE FULLY FORWARD UNTIL IT CATCHES THE HOOK THEN PULL THE HANDLE BACK DOWN AND PUSH IT FIRMLY CLOSED
- PLACE THE SEAT SPACER (119) ON THE UNDERSIDE OF THE RAIL (THE SEAT SPACER CAN BE PLACED ON THE TOP OF THE RAIL AT THE REAR TO PREVENT THE SEAT FROM CONTACT WITH THE GROUND ONLY WHEN MOVING THE ROWER TO A FOLDED POSITION)

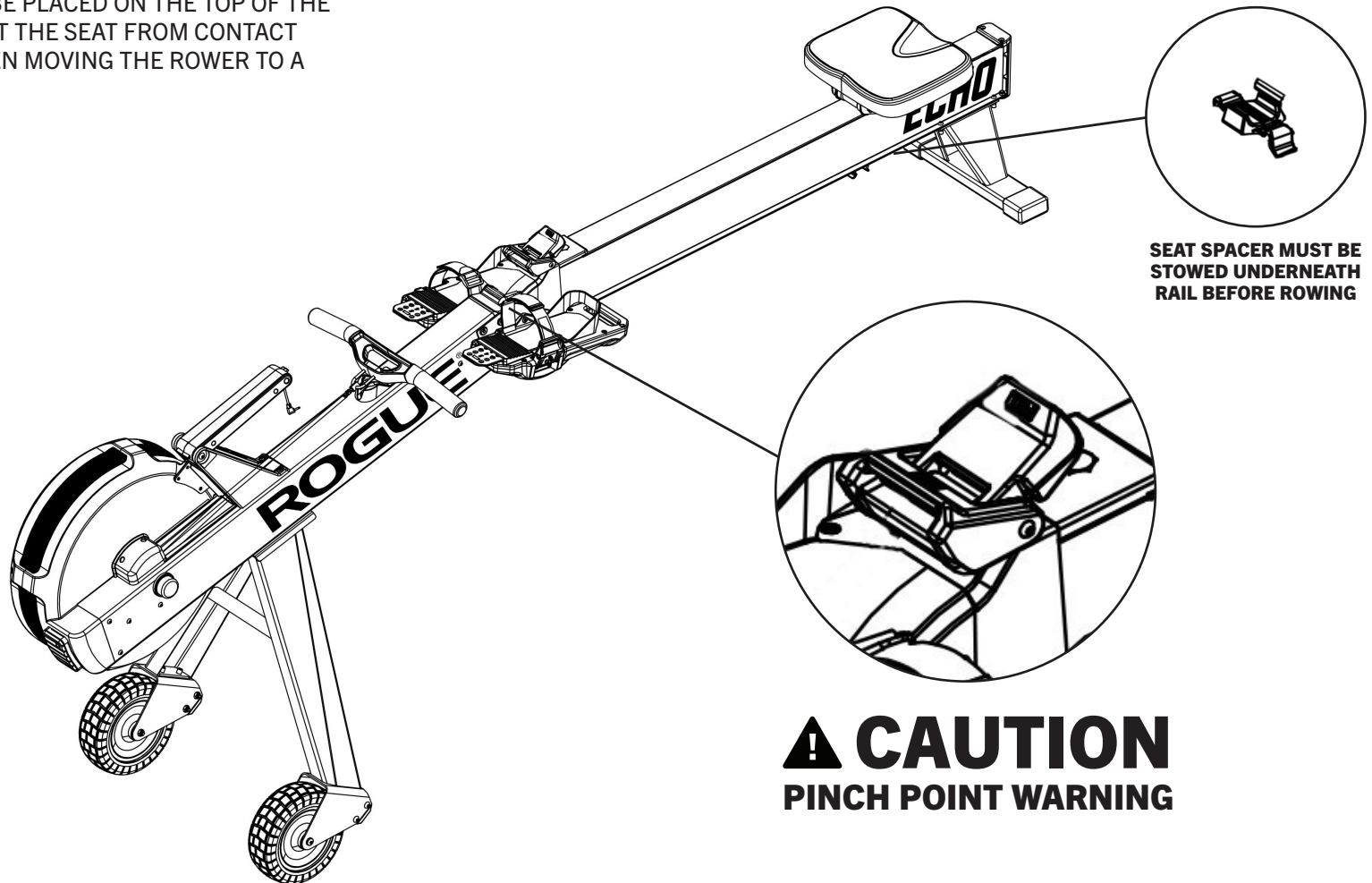

STEP 10

- IF THE BATTERIES ARE NOT PRE-INSTALLED INTO THE CONSOLE (74) INSTALL THESE PRIOR TO ATTACHING THE CONSOLE TO THE ROWER FOLLOWING THE STEPS OUTLINED BELOW
- REMOVE THE SINGLE THROUGH BOLT AND NUT FROM THE REAR OF THE CONSOLE AND ALIGN THE CONSOLE WITH THE MOUNT POINT AT THE END OF THE PIVOT ARM ENSURING THAT THE CONNECTING WIRE IS NOT TRAPPED OR PINCHED
- REINSERT THE THROUGH BOLT AND SECURE IT WITH THE T27 TORX WRENCH, TIGHTENING IT UP TO THE POINT WHERE IT HAS ENOUGH FRICTION TO HOLD THE MONITOR UP
- INSERT THE CONNECTING WIRE INTO THE SIDE OF THE CONSOLE

1. REMOVE THE BATTERY COVER FROM THE CONSOLE BY USING THE PROVIDED PHILLIPS HEAD SCREWDRIVER TO REMOVE THE FOUR SCREWS.



2. INSTALL 2 D-CELL (1.5V) BATTERIES ALIGNING POSITIVE AND NEGATIVE ENDS WITH THE CORRESPONDING SYMBOLS.

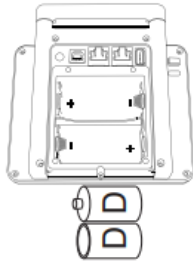

3. REATTACH THE BATTERY COVER WITH THE FOUR SCREWS FASTENED IN PLACE.

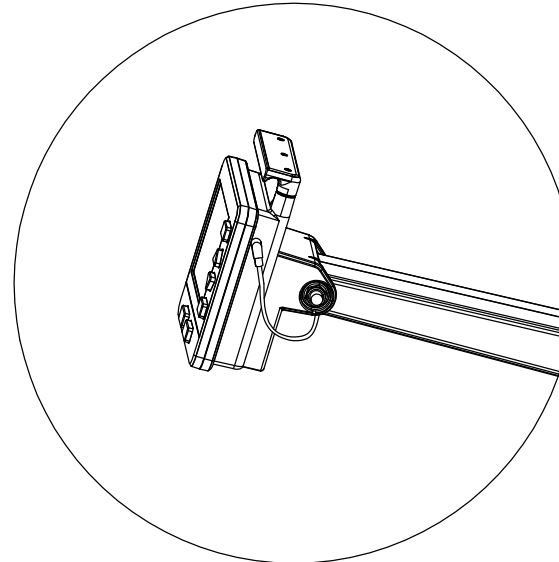
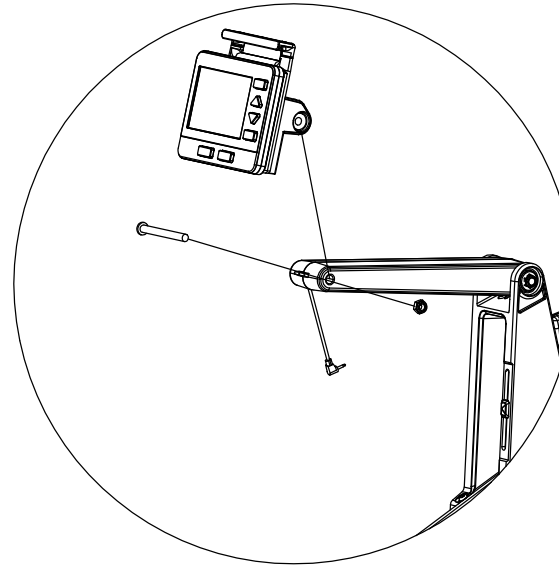
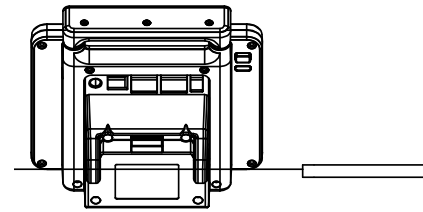
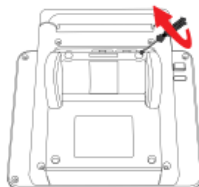

STEP 11

- BEFORE ROWING, CHECK TO MAKE SURE THAT THE ROWER MAIN FRAME IS STABLE AND THE RAIL IS LOCKED, ALL FASTENERS ARE TIGHTENED AND SECURE AND THAT ALL PACKAGING HAS BEEN REMOVED FROM THE ROWER AREA
- ENSURE THAT THE SEAT SPACER IS REMOVED FROM THE TOP RAIL AND STOWED SAFELY ON THE UNDERSIDE OF THE RAIL
- YOU ARE NOW READY TO ROW
- ROW EASY AT FIRST TO CONFIRM FUNCTION

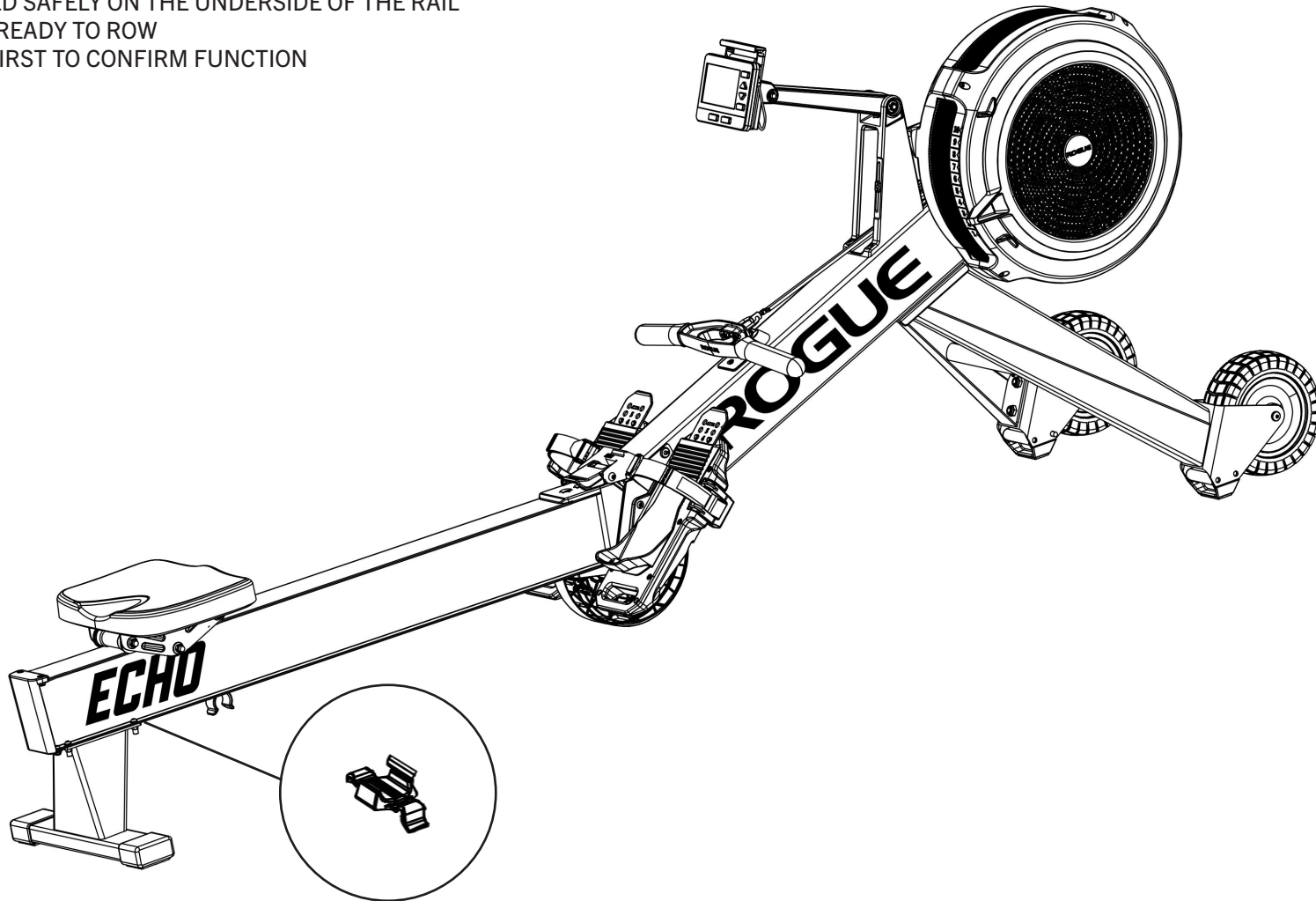

**SEAT SPACER MUST BE
STOWED UNDERNEATH
RAIL BEFORE ROWING**

FOLDING THE ROWER FOR STORAGE

- TO PREVENT THE SEAT FROM CONTACTING THE GROUND WHEN MOVING THE FOLDED ROWER, PLACE THE SEAT SPACER ON TOP OF THE MONORAIL, BEHIND THE SEAT, AND SLIDE IT TO THE REAR OF THE MONORAIL
- LIFT THE REAR LATCH (95) UP BY HAND, AND THE ENTIRE BUCKLE WILL BE RELEASED, ALLOWING THE FRONT AND REAR FRAMES TO FOLD UP

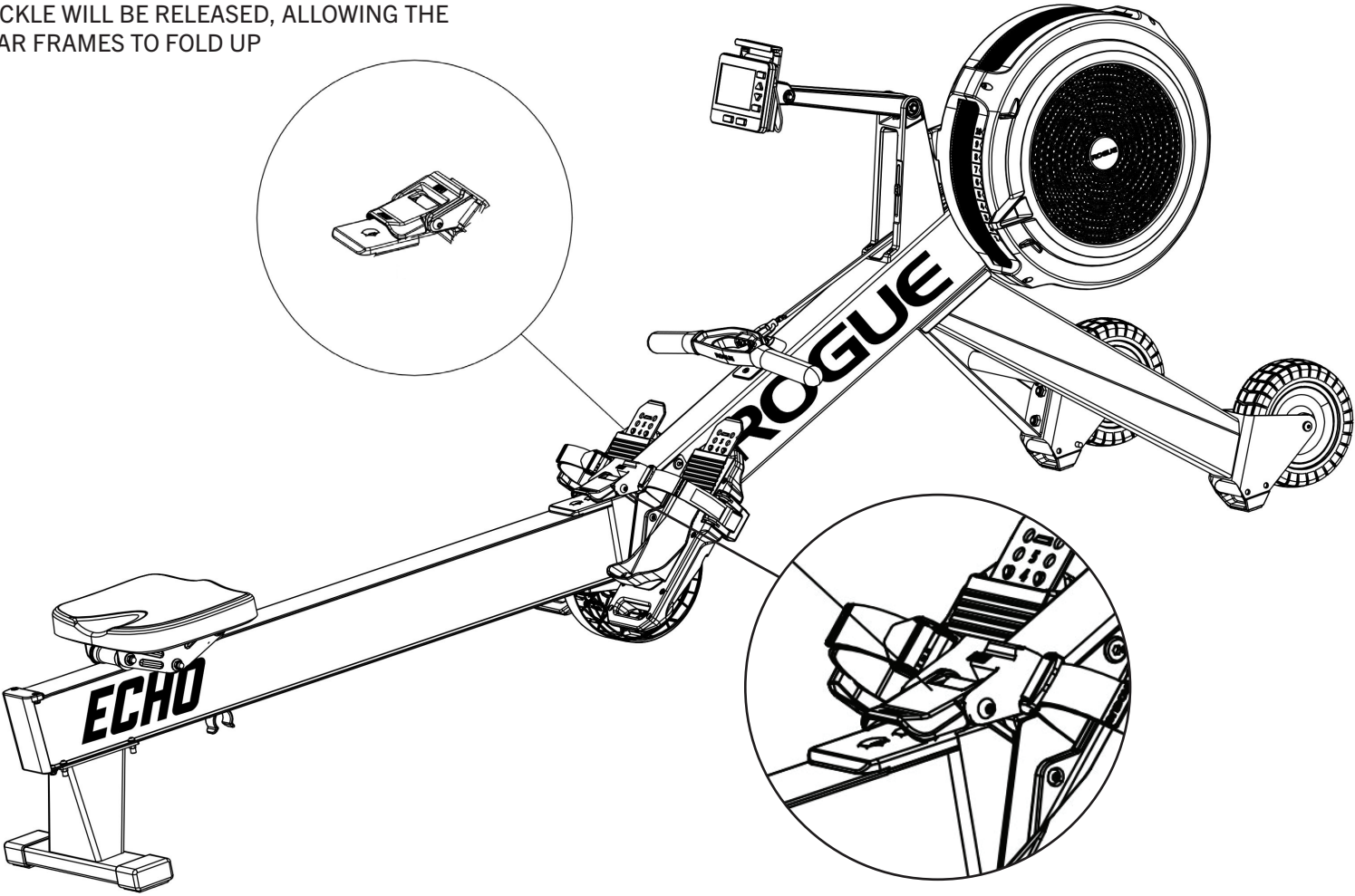

⚠ CAUTION
PINCH POINT WARNING

ROGUE



**SCAN FOR
INSTRUCTIONS**

ROGUE



**IRON GAME
PROGRAMMING**