

ROGUE®

FM-6 FUNCTIONAL TRAINER

WEIGHT STACK OPTION

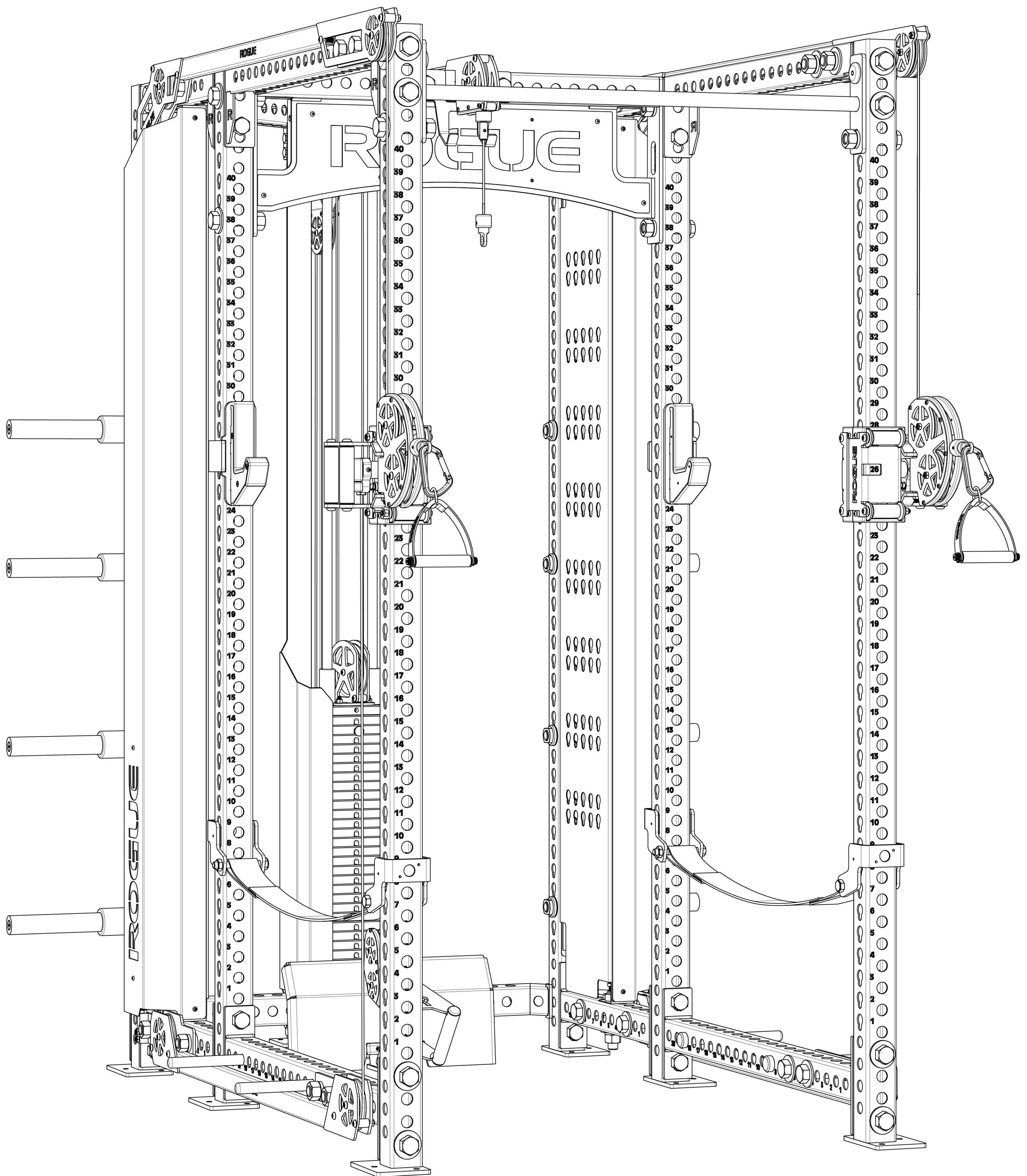

⚠ IMPORTANT SAFETY INFORMATION

DISCLAIMER:

Resistance training, gymnastics training, and activities at height are potentially dangerous and may lead to severe injury or even death. Use common sense when training, obtain instruction in the proper execution of movements, and understand your limitations. This equipment must only be used by competent and responsible persons. Obtaining instruction in appropriate techniques and methods of use is your own responsibility. You assume all risks and responsibilities for all damage, injury or death which may occur during or following incorrect use of this equipment in any matter whatsoever. Rogue Fitness bears no liability beyond the replacement value of the equipment in question.

WARNING:

THIS RACK MUST BE BOLTED TO THE FLOOR BEFORE USE. MINIMUM TWO PEOPLE REQUIRED FOR SAFE ASSEMBLY. MISUSE OF THIS RACK CAN RESULT IN SEVERE INJURY.

Both Rogue Fitness and buyer disclaim any express or implied warranty, including, without limitation, warranties or merchantability and/or fitness for a particular purpose with respect to the equipment. Buyer assumes all liability to use of equipment.

TABLE OF CONTENTS

RM-6 RACK

Included Tools.....	3
Included Parts.....	4
Assembly.....	15

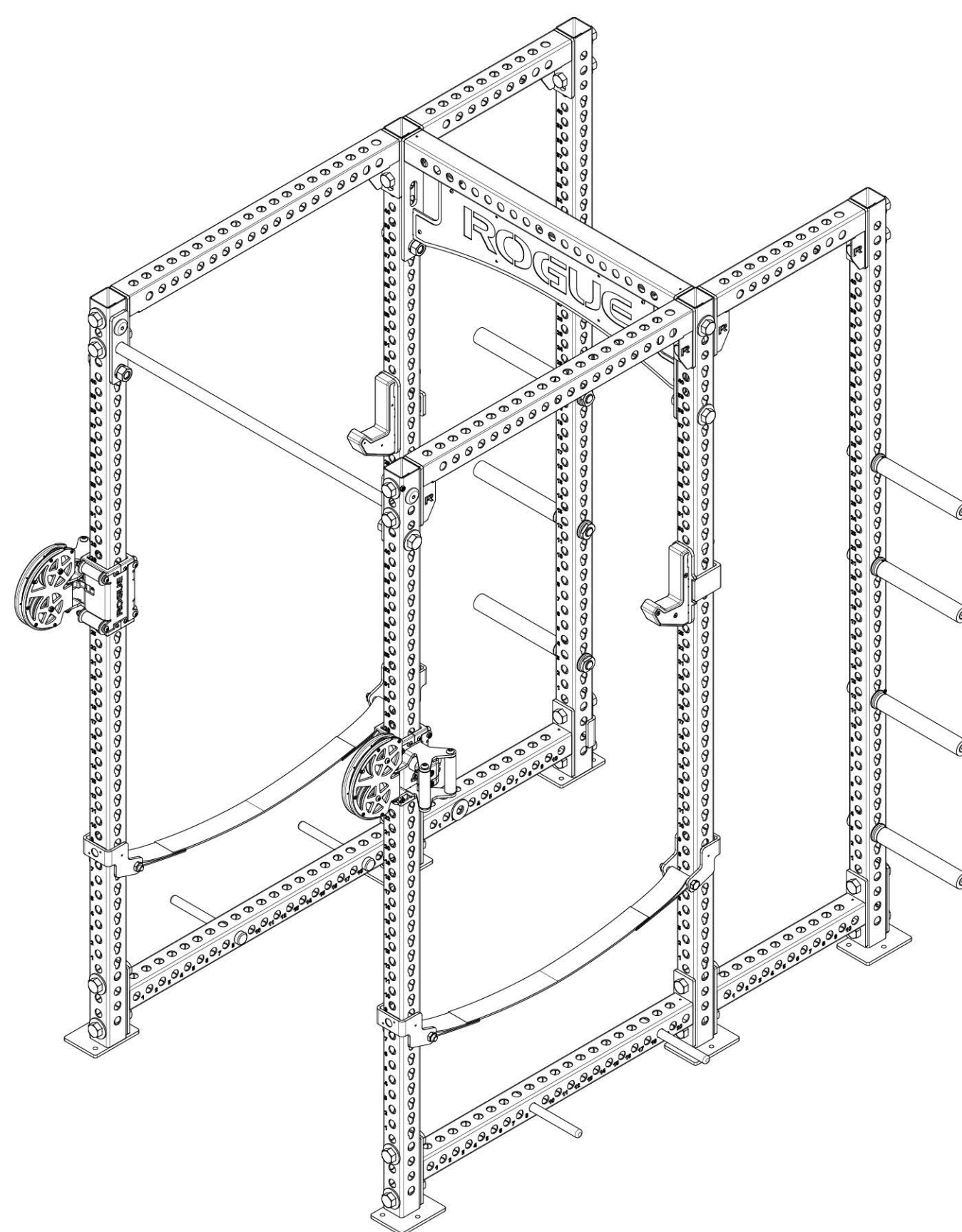

FM-6 ADD-ON KIT

Included Tools.....	3
Included Parts.....	6
Assembly.....	19

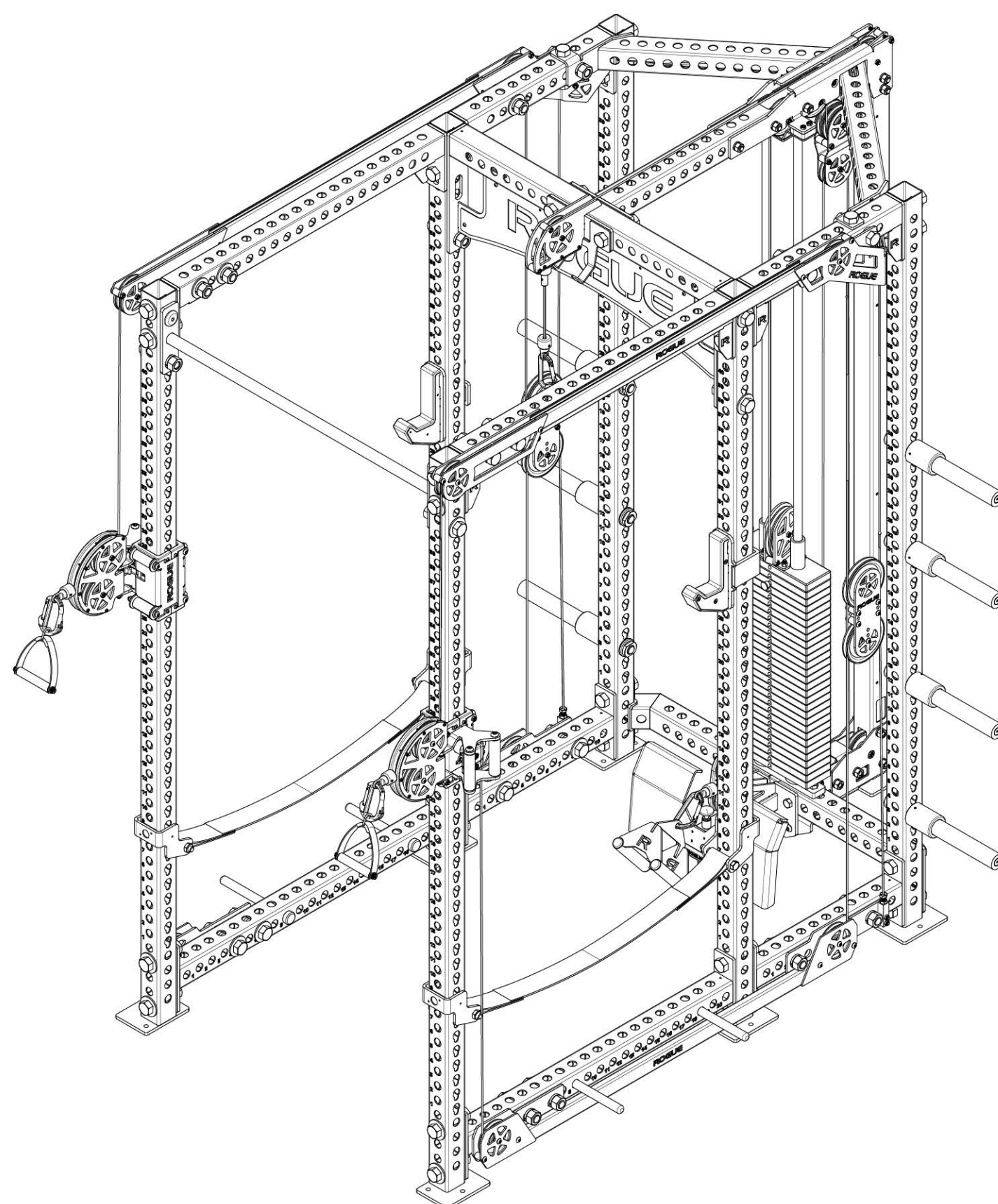

FM-6 SHROUD KIT

Included Tools.....	3
Included Parts.....	12
Assembly.....	53

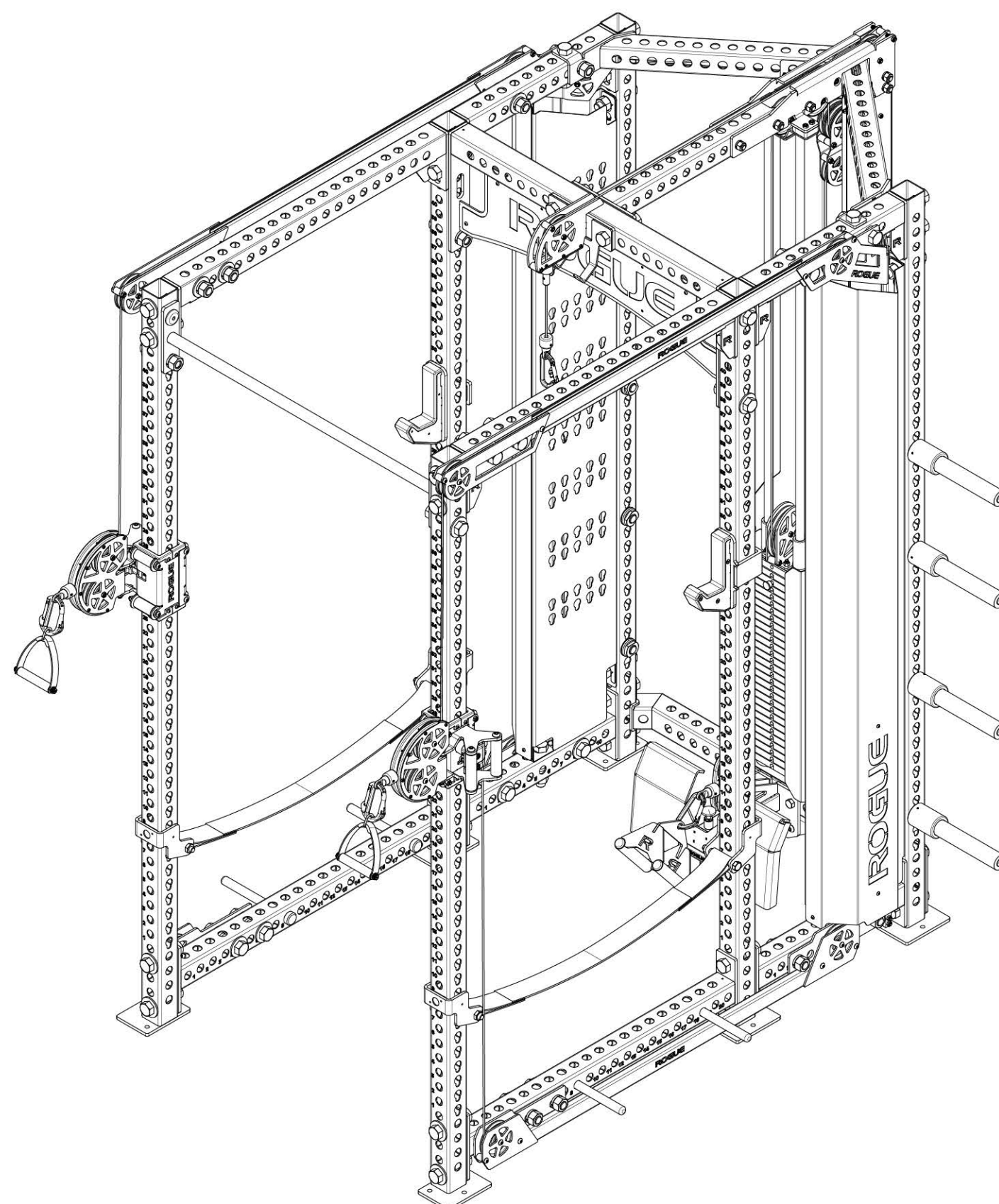

INCLUDED TOOLS

Note: Images not shown at scale

1 Qty: **2x**

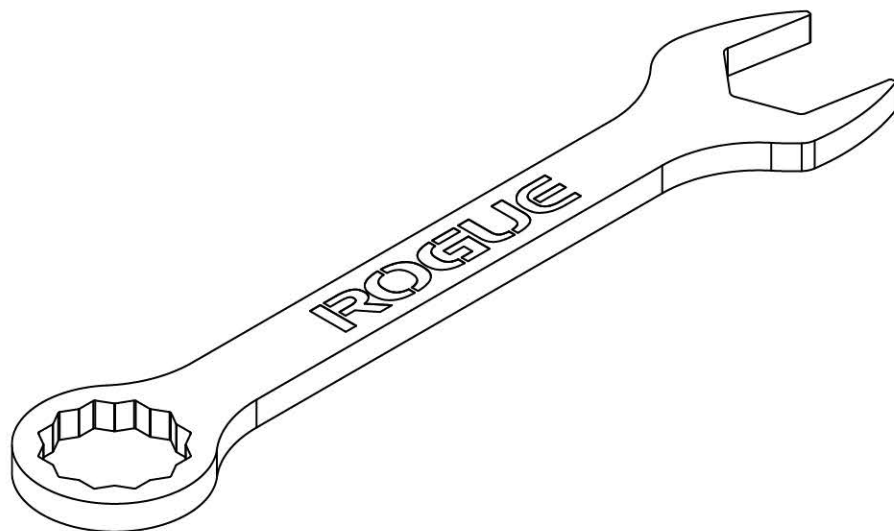

1-1/2" Wrench

2 Qty: **2x**

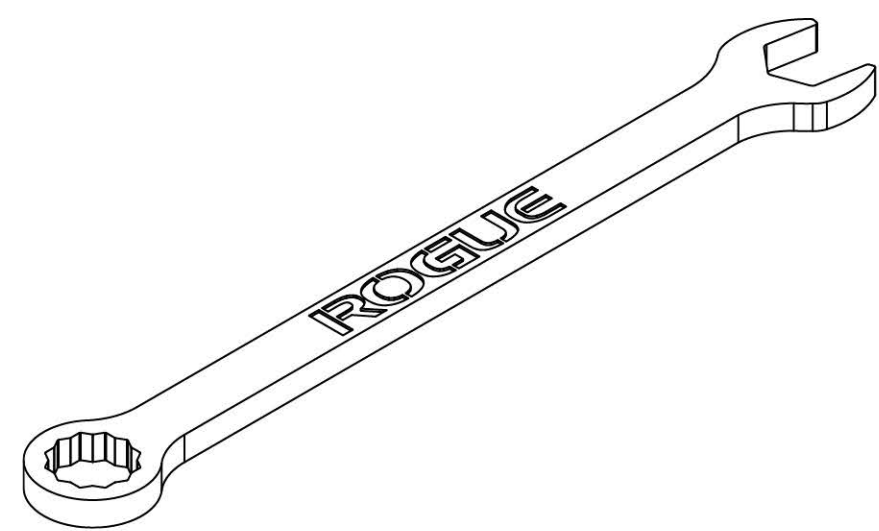

15/16" Wrench

3 Qty: **1x**

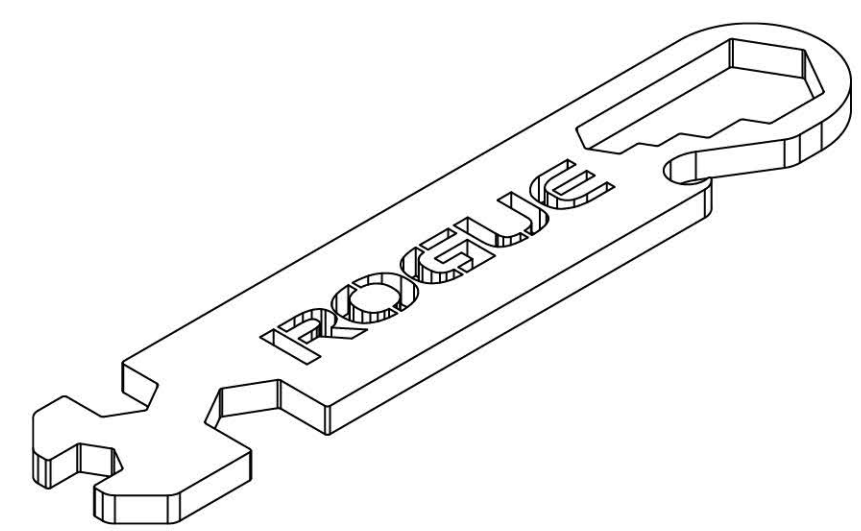

Multi Tool (3/4", 9/16", and 7/16" Wrench)

4 Qty: **1x**

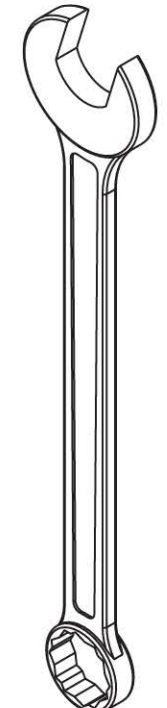

5/8" Wrench

5 Qty: **1x**

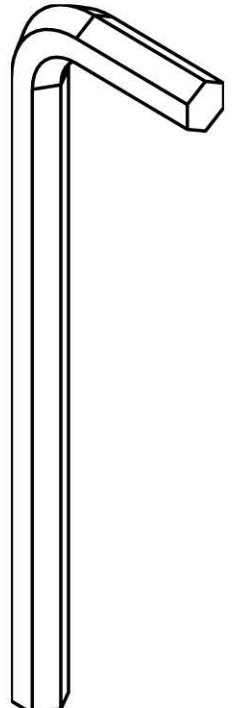

3/8" Allen Key

6 Qty: **1x**

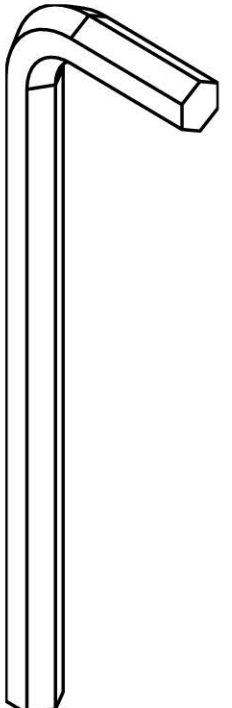

5/16" Allen Key

7 Qty: **1x**



7/32" Allen Key

8 Qty: **1x**



5/32" Allen Key

9 Qty: **1x**

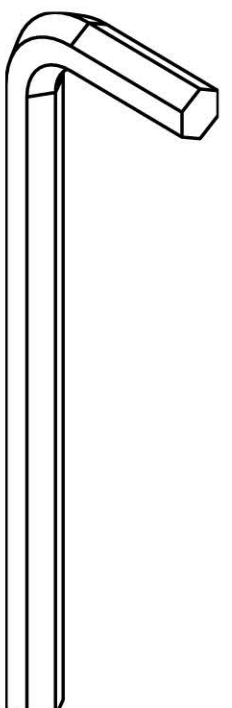

1/8" Allen Key

10 Qty: **1x**

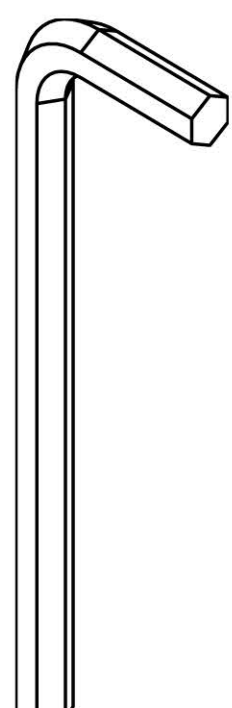

3/32" Allen Key

INCLUDED PARTS: RM-6 FULL RACK

Note: Images not shown at scale.

1 Qty: **6x**

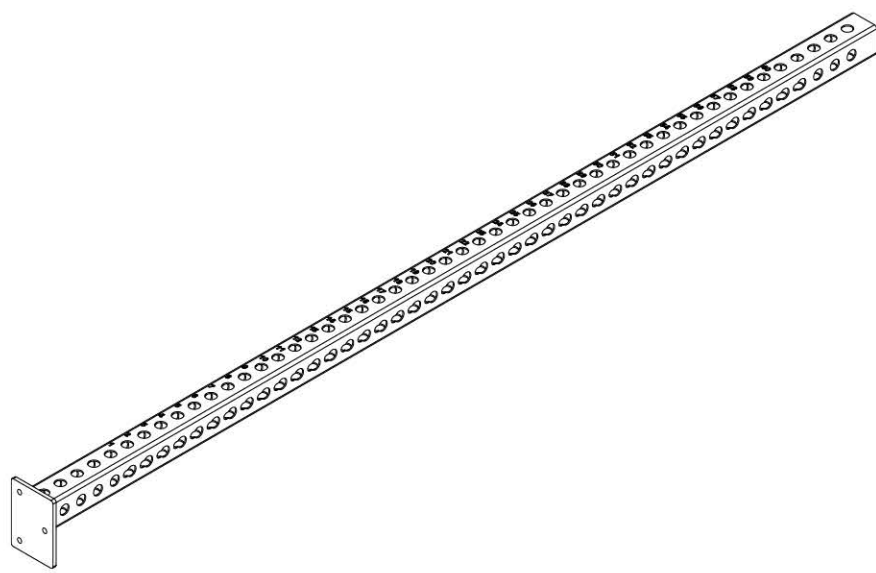

90" or 100" Monster Upright

2 Qty: **2x**

*

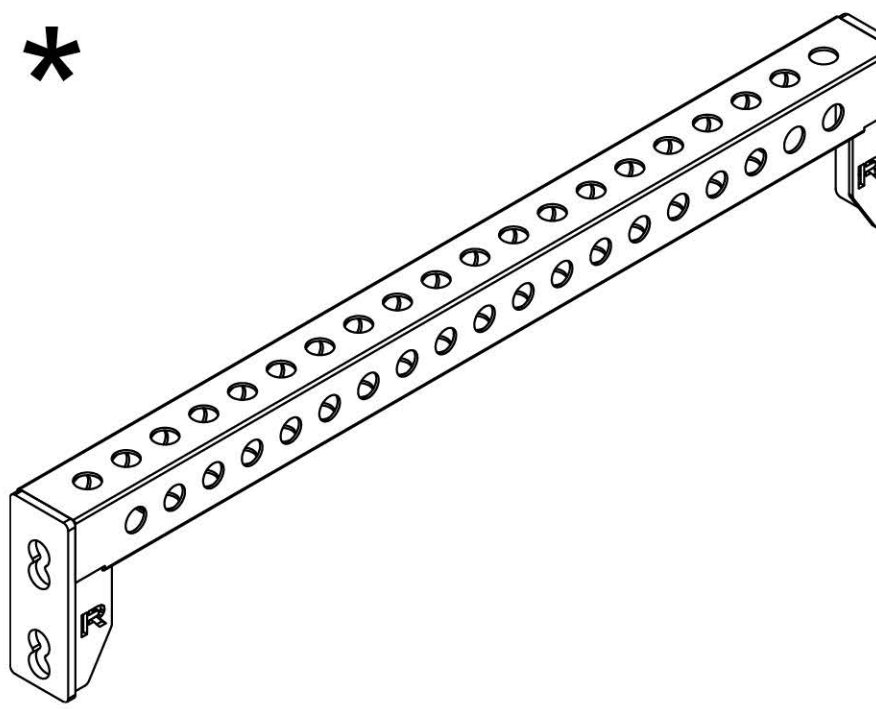

Front Top Crossmember

3 Qty: **2x**

*

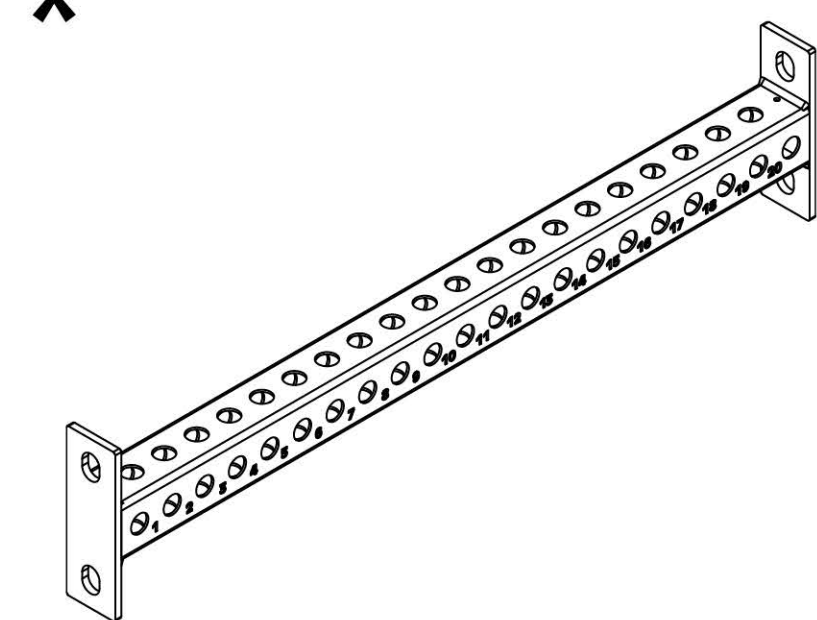

Front Low Crossmember

4 Qty: **2x**

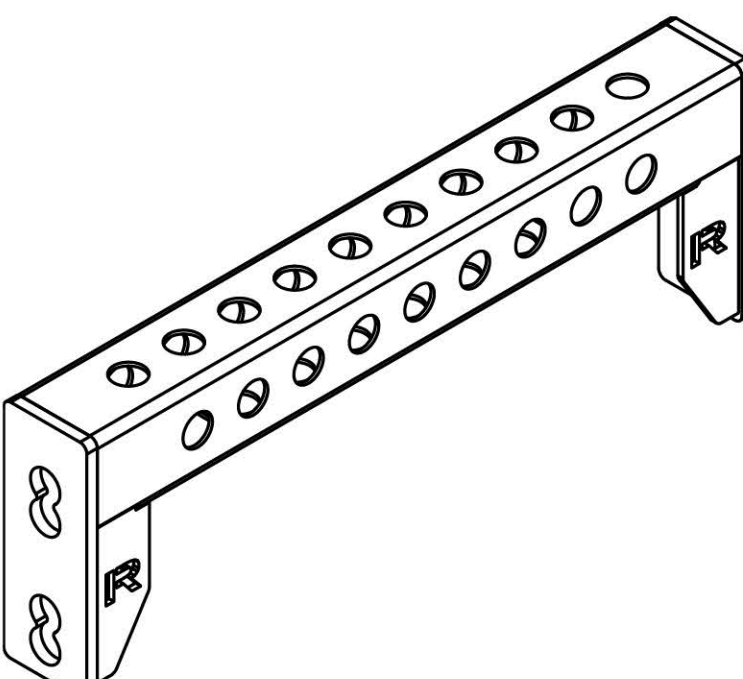

24" Rear Top Crossmember

5 Qty: **2x**

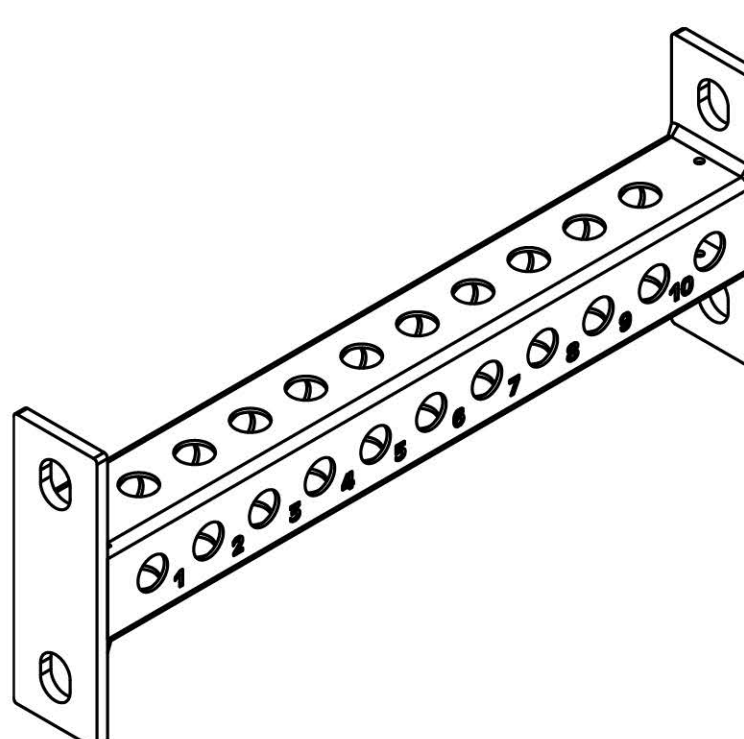

24" Rear Low Crossmember

6 Qty: **1x**

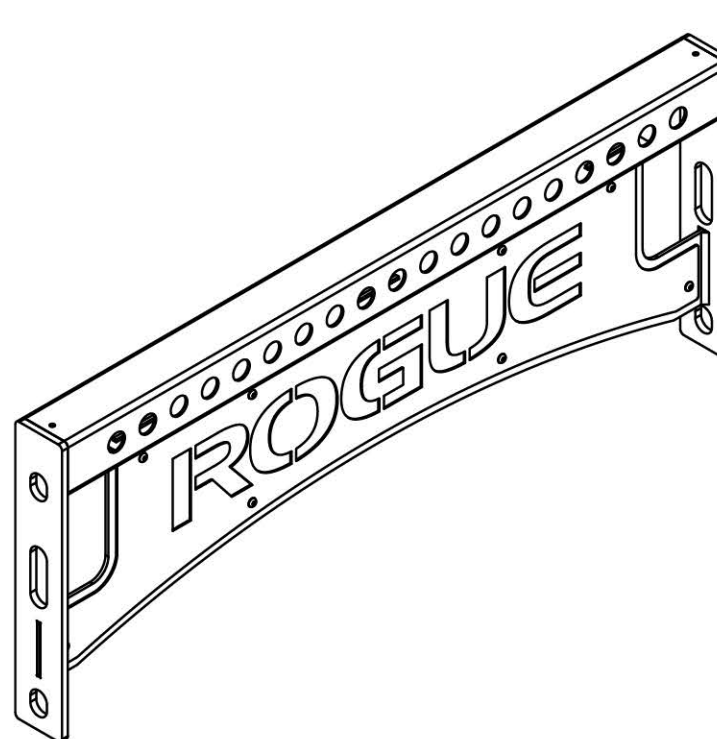

Nameplate Crossmember

7 Qty: **1x**

**

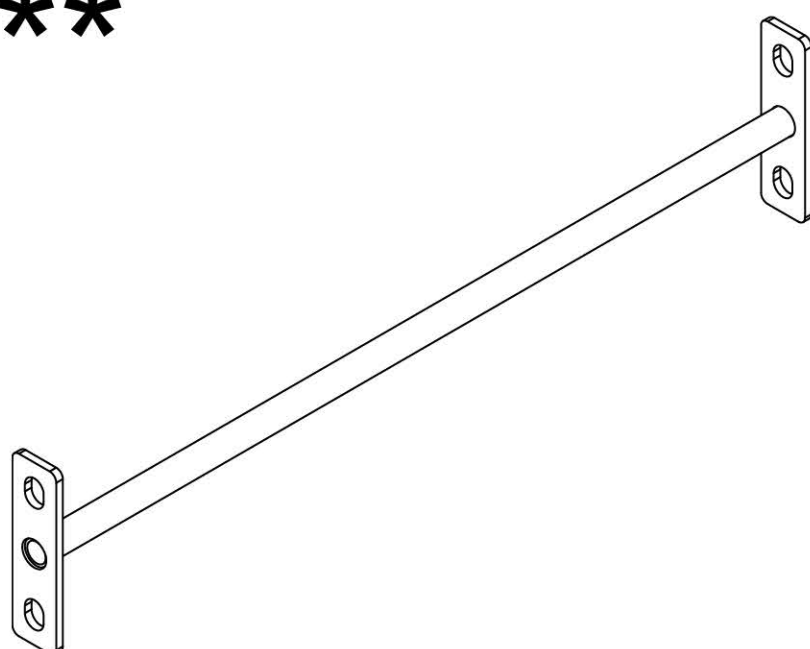

Pull-up Bar

8 Qty: **8x**

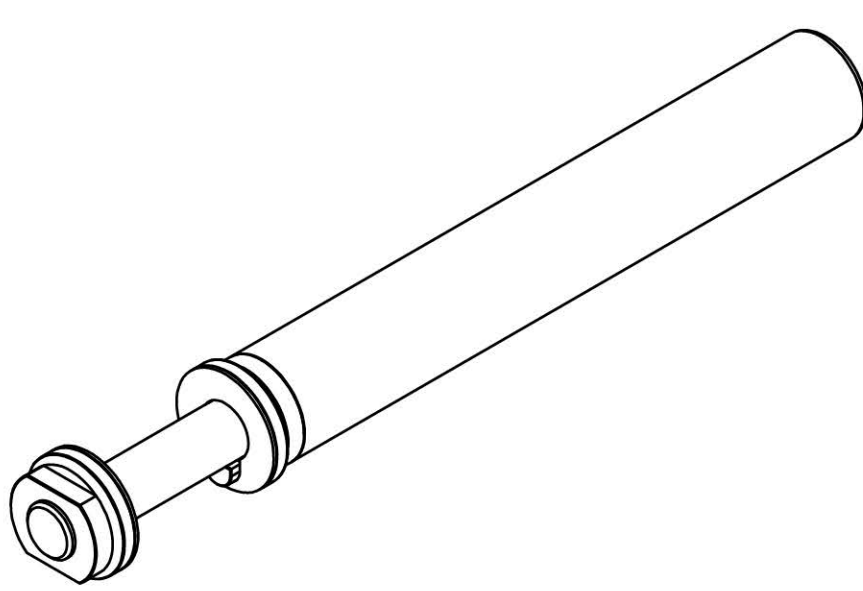

Monster Plate Storage Pin

9 Qty: **1x**

**



Pair of Safety Spotter Arms

10 Qty: **4x**

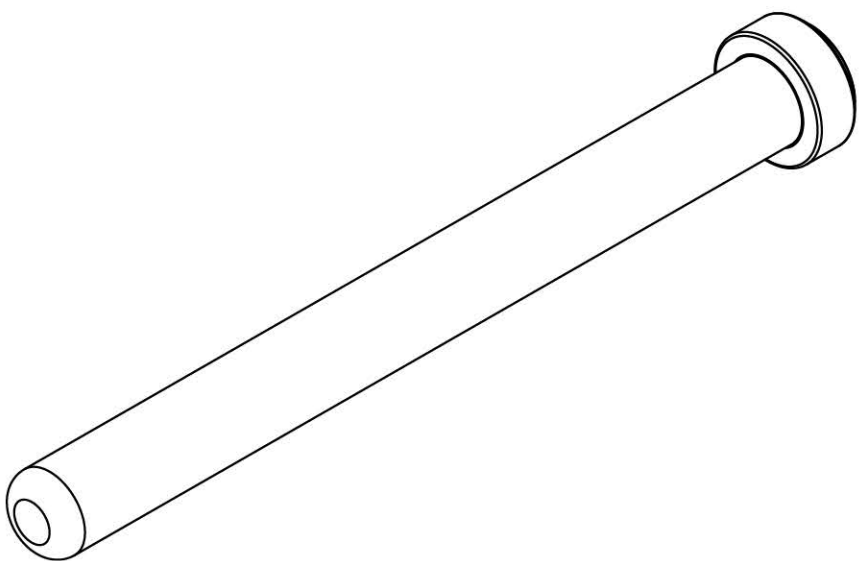

Band Peg

11 Qty: **1x**

**

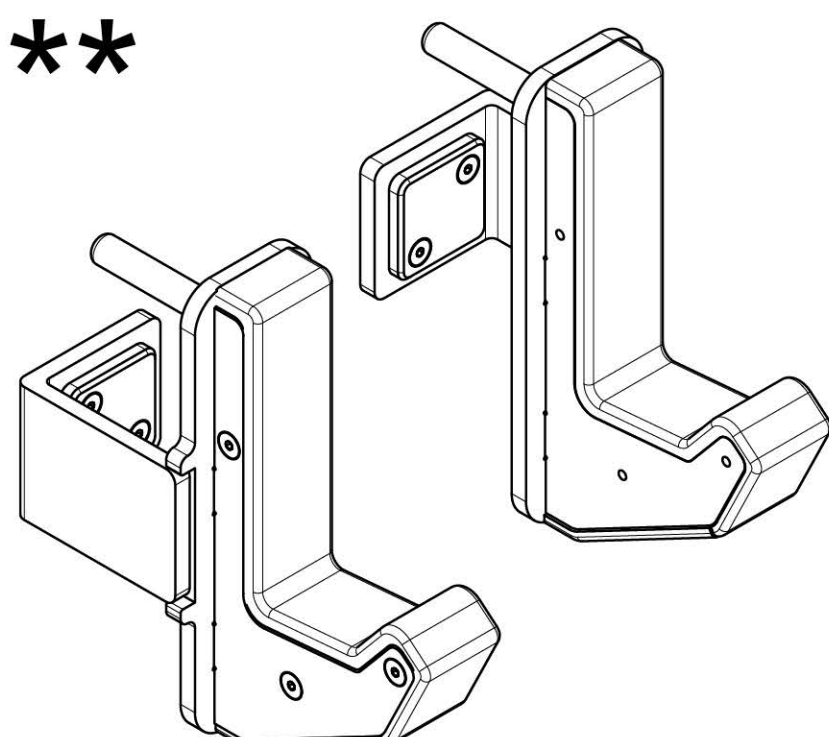

Pair of Monster J-cups

12 Qty: **8x**

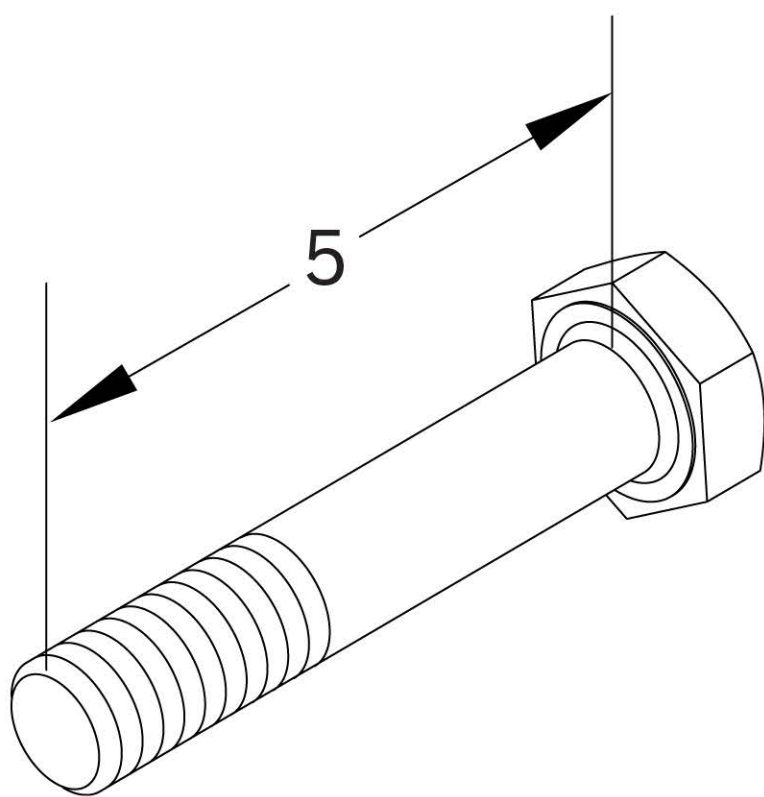

1" x 5" Hex Bolt

* Front Crossmember length depends on Rack Depth selection made at checkout.

** Items may look different than drawings shown. Style depends on selection made at checkout.

INCLUDED PARTS: RM-6 FULL RACK

Note: Images not shown at scale.

13 Qty: **24x**

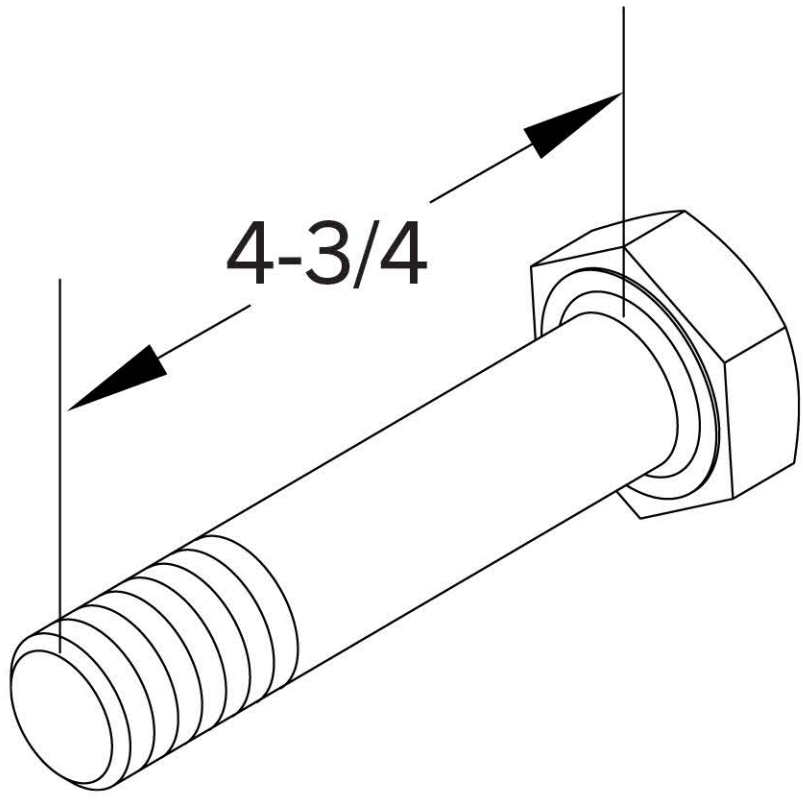

1" x 4-3/4" Hex Bolt

14 Qty: **24x**

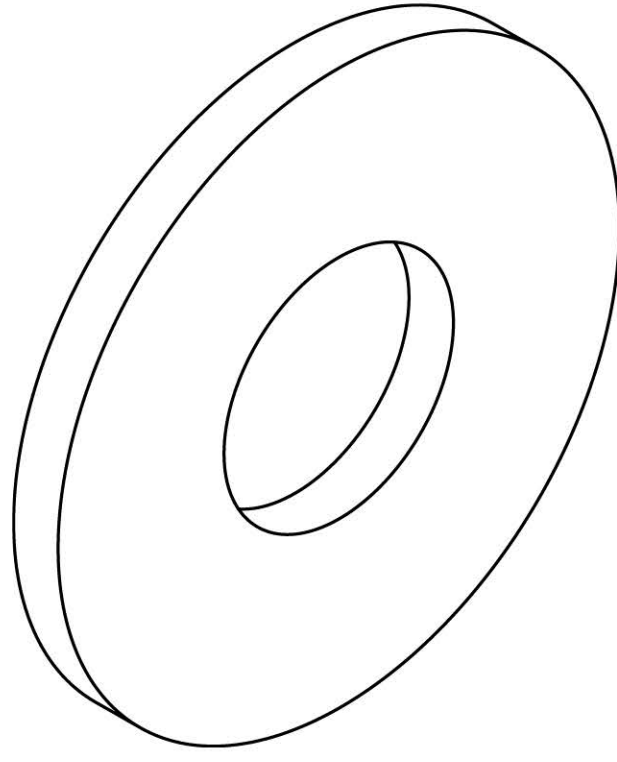

1" Flat Washer

15 Qty: **32x**

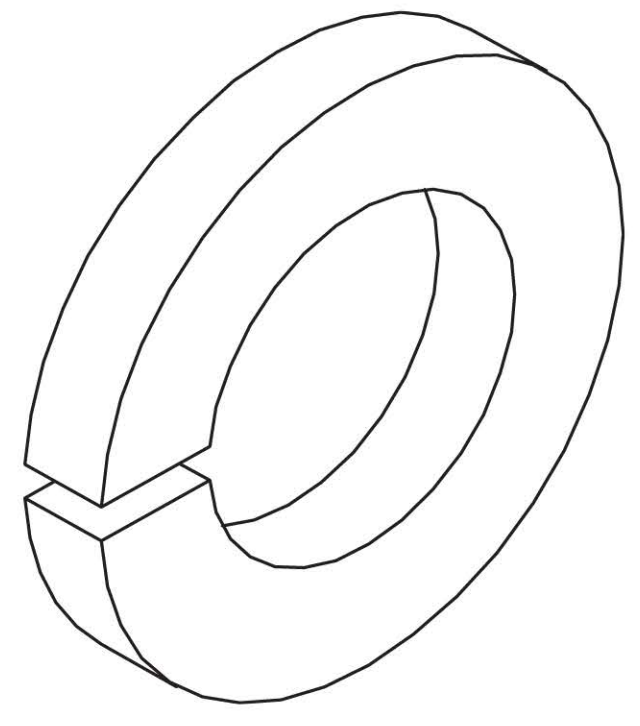

1" Lock Washer

16 Qty: **32x**

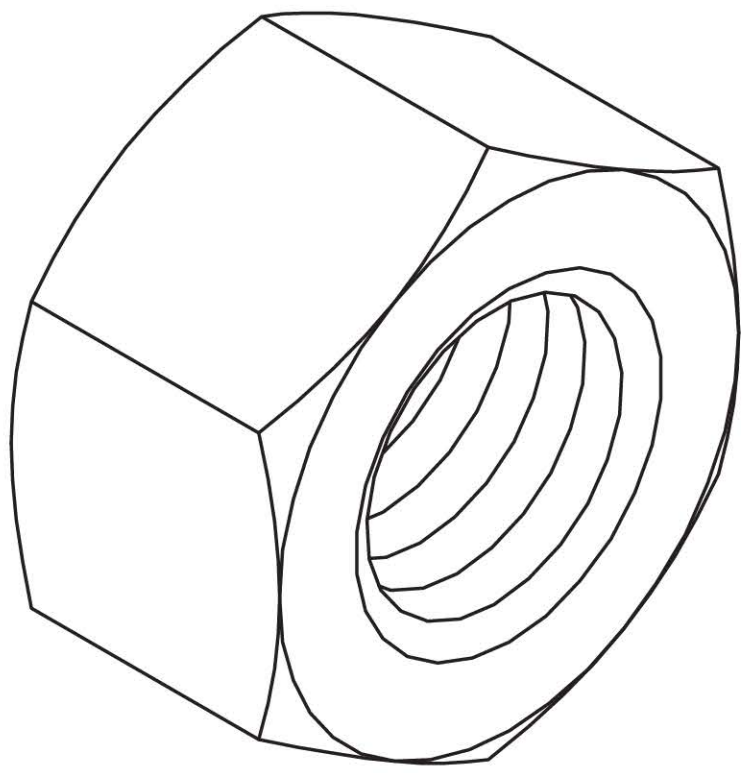

1" Hex Nut

INCLUDED PARTS: FM-6 ADD-ON KIT

Note: Images not shown at scale.

17 Qty: **1x**

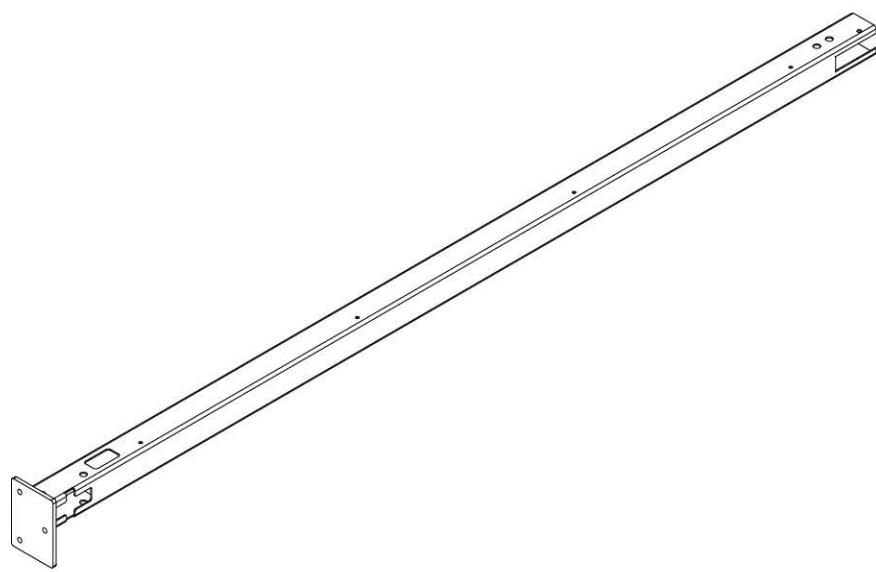

90" or 100" Rear 3X3 Upright

18 Qty: **1x**

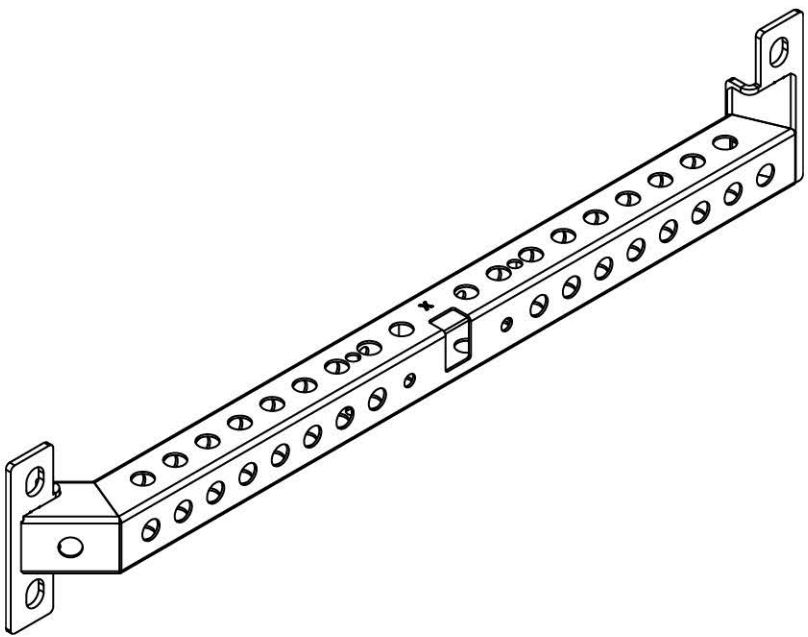

Low Row Crossmember

19 Qty: **1x**

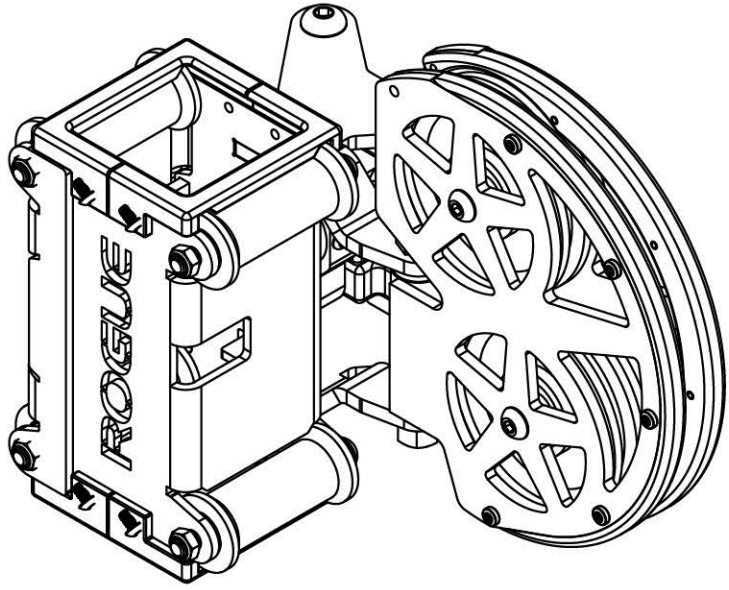

Swivel Trolley RH

20 Qty: **1x**

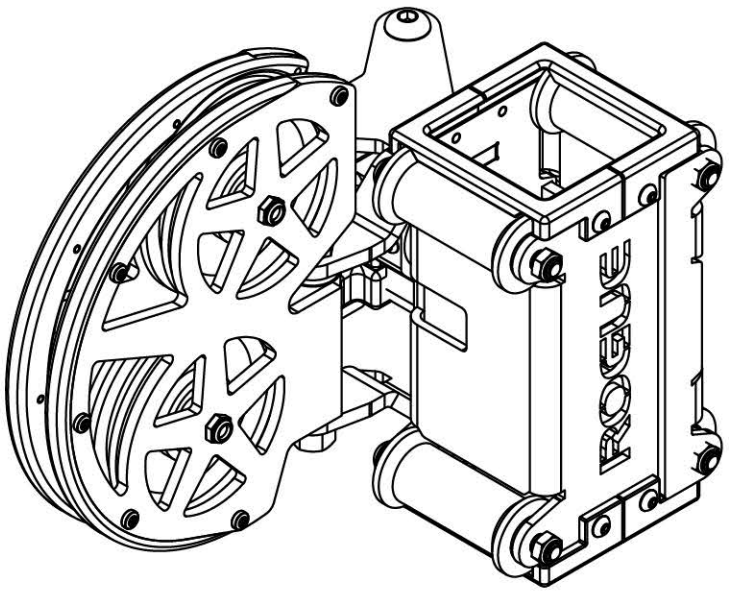

Swivel Trolley LH

21 Qty: **1x**

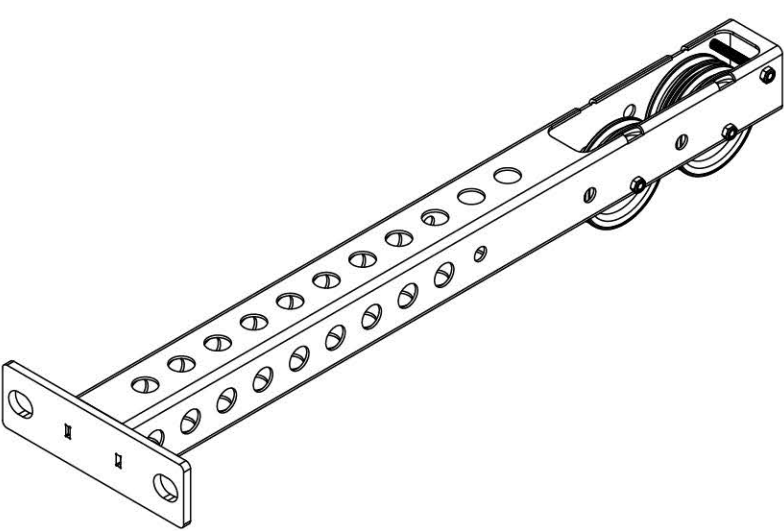

Top Center Crossmember

22 Qty: **1x**

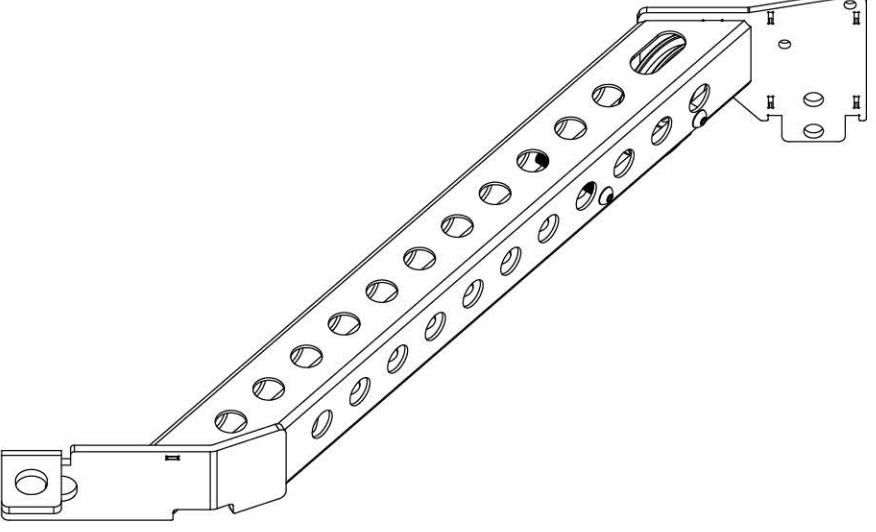

Top Rear Angle Crossmember - RH

23 Qty: **1x**

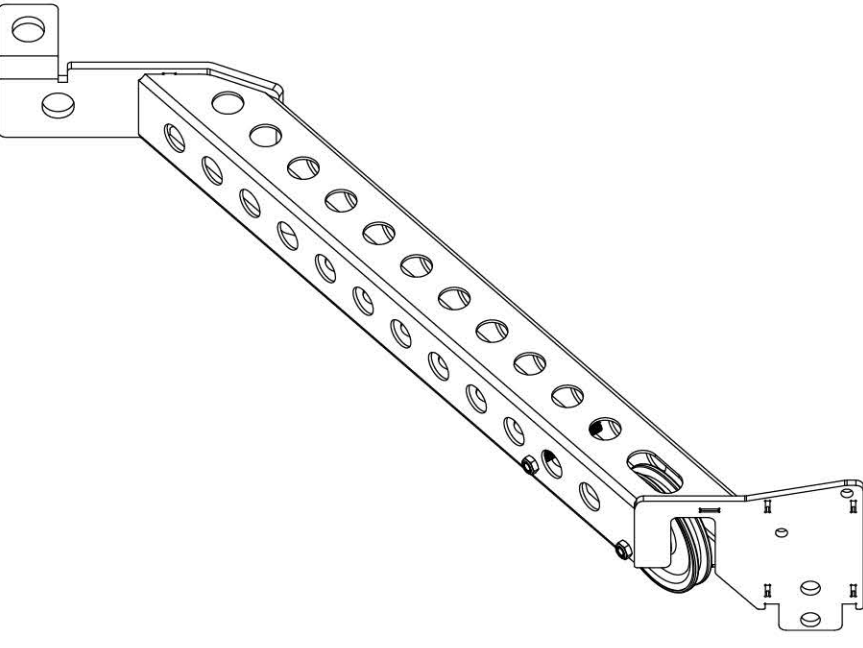

Top Rear Angle Crossmember - LH

24 Qty: **1x**

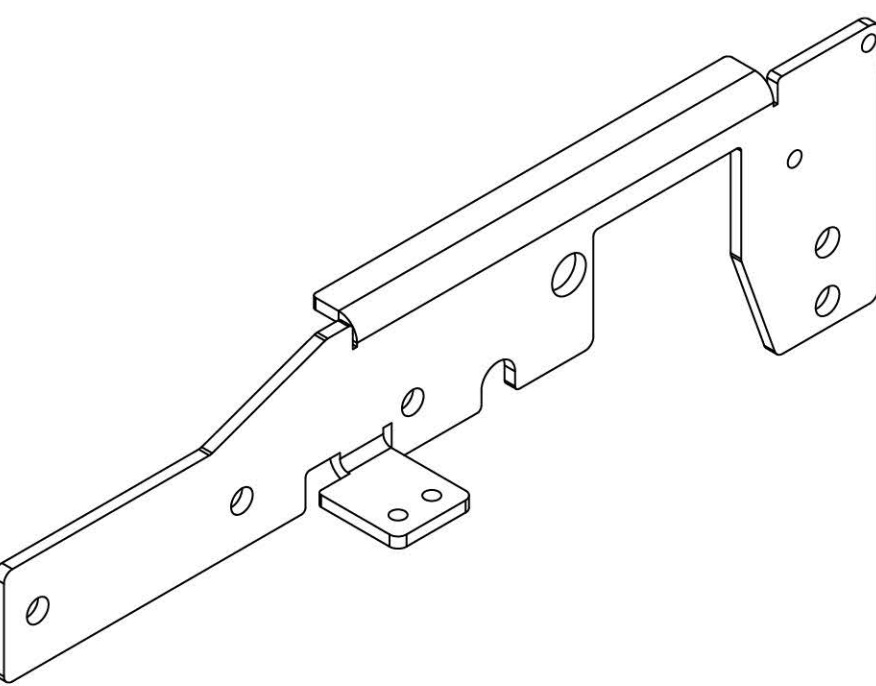

Top Rear Connector Plate - RH

25 Qty: **1x**

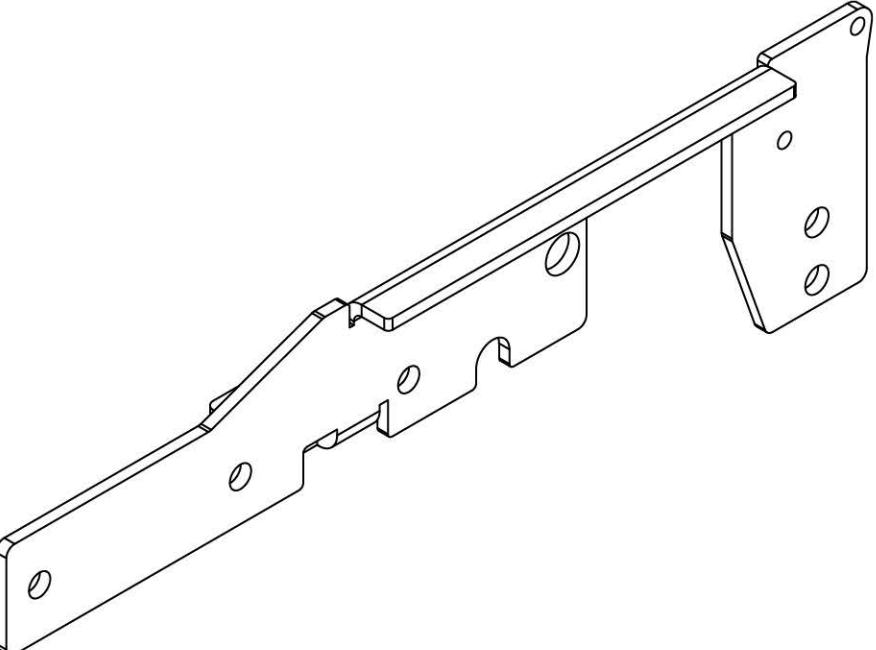

Top Rear Connector Plate - LH

26 Qty: **1x**

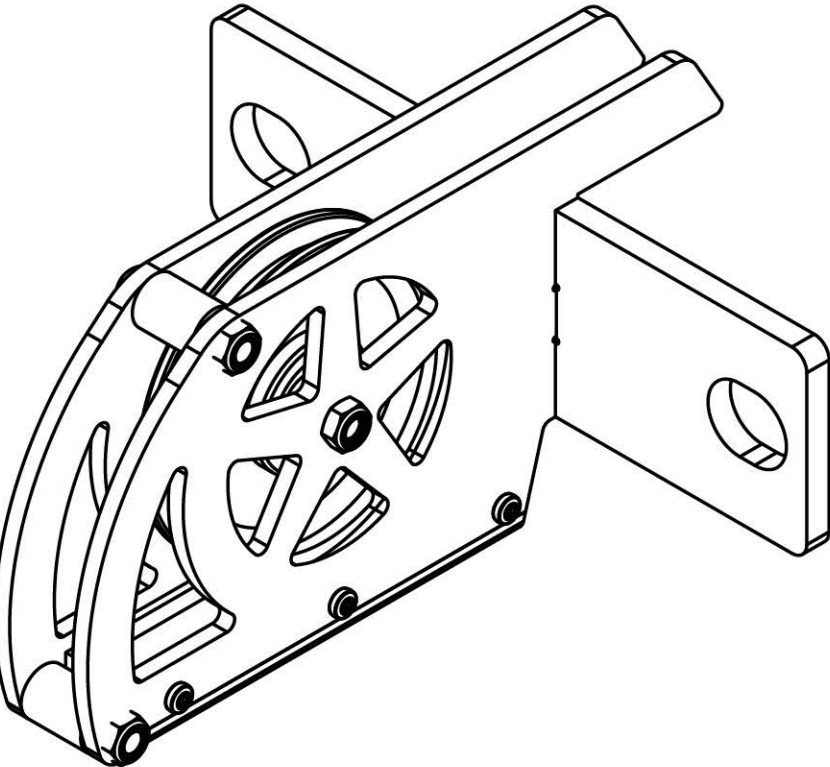

Lat Pulldown Pulley Bracket

27 Qty: **1x**

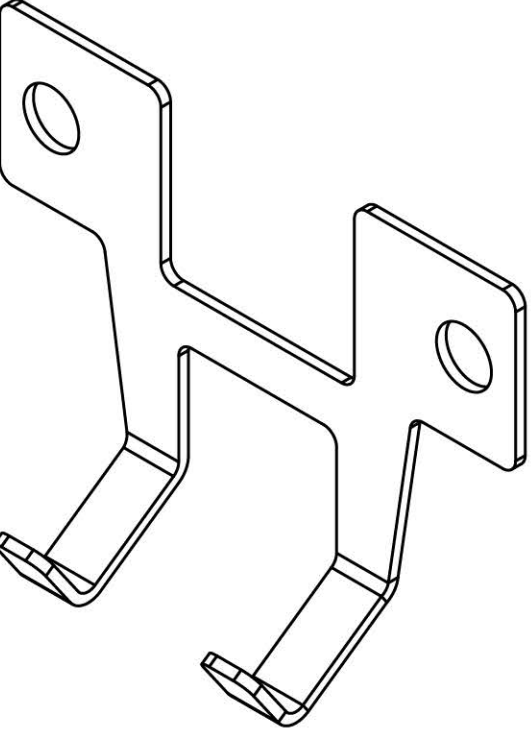

Lat Bar Hanger

28 Qty: **1x**



Low Row Footplate Assembly

INCLUDED PARTS: FM-6 ADD-ON KIT

Note: Images not shown at scale.

29 Qty: **1x**

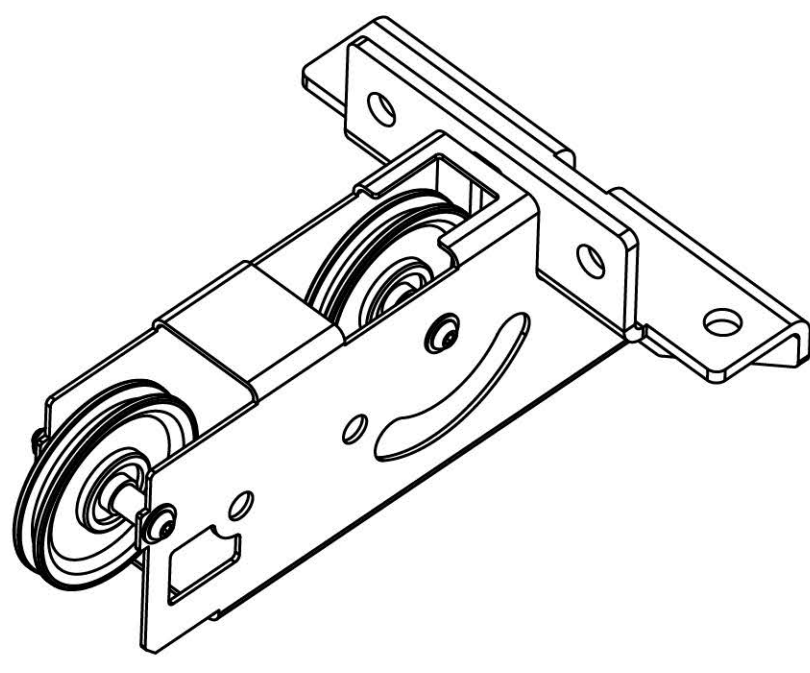

Low Rear Pulley Assembly

30 Qty: **2x**

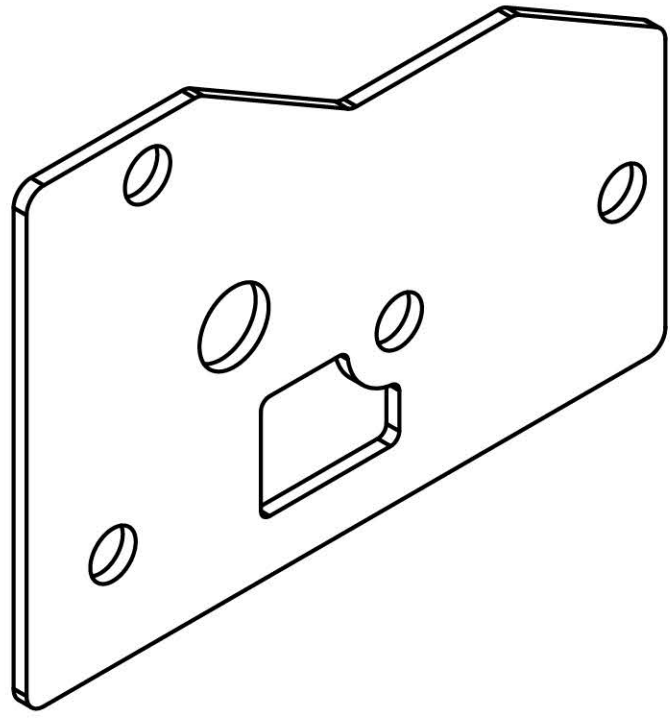

Rear Connector Plate

31 Qty: **2x**

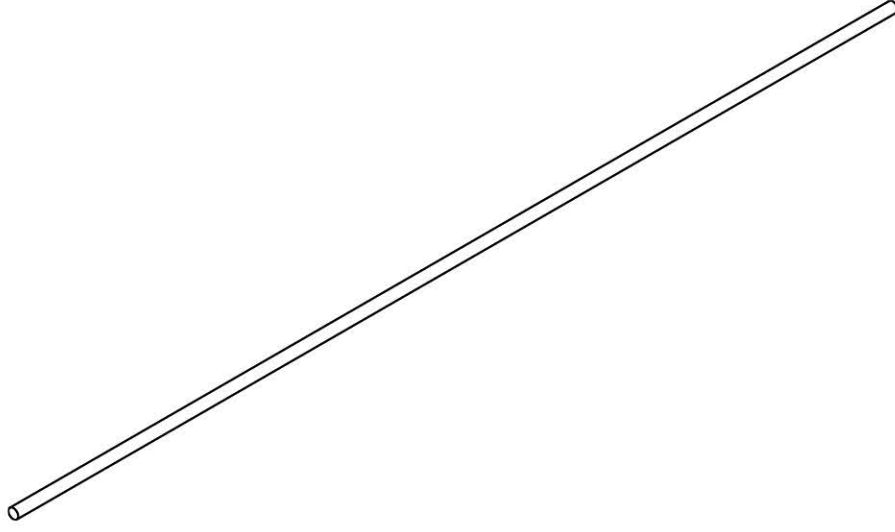

Guide Rod

32 Qty: **1x**

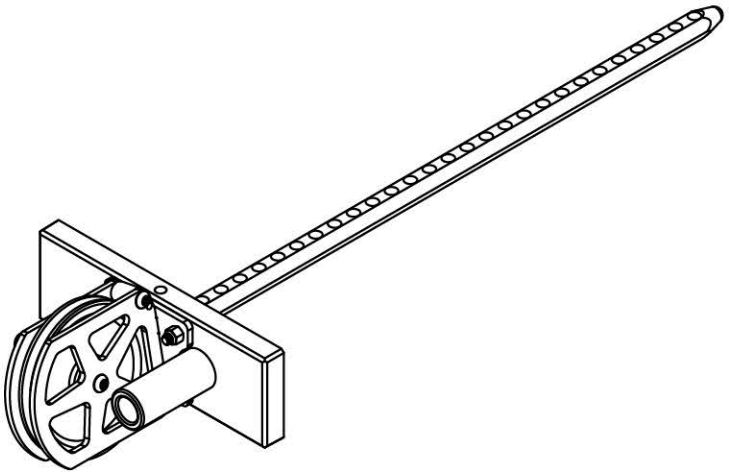

Weight Stack Stem

33 *Qty: **23x or 28x**

*

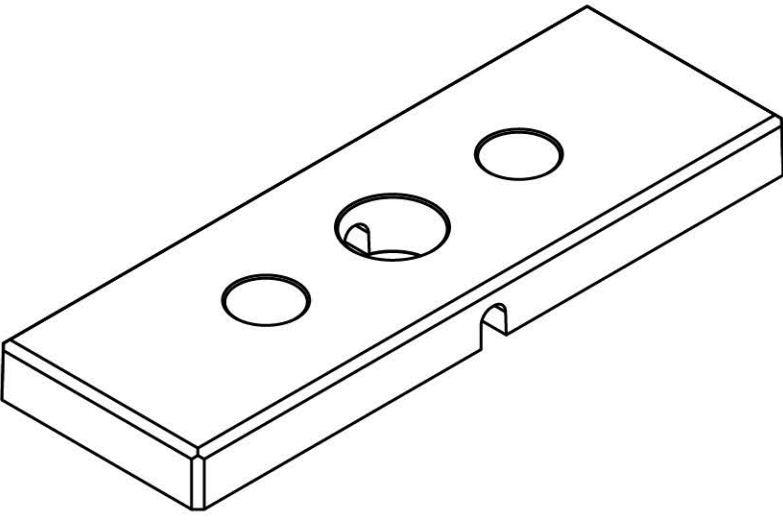

10LB Weight Stack Plate

34 Qty: **1x**



Weight Stack Selector Pin w/ Lanyard

35 Qty: **1x**

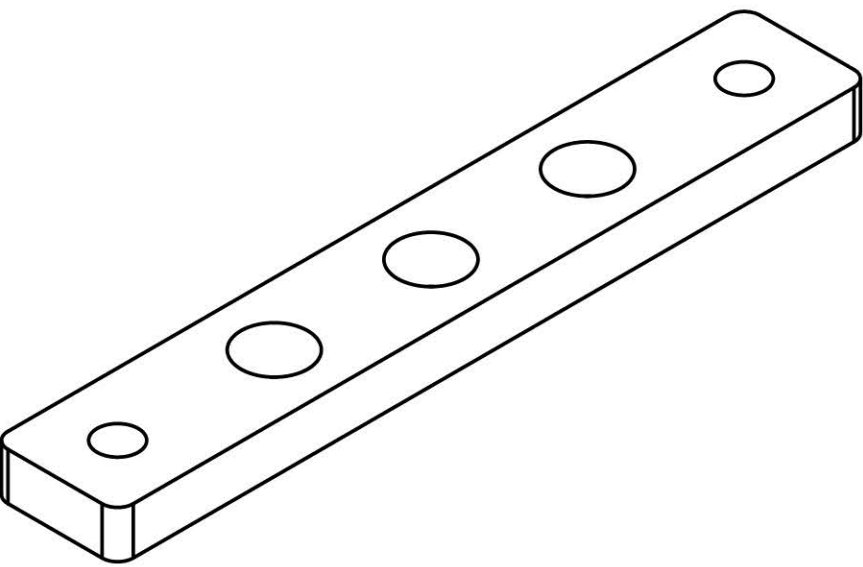

Weight Stack Spacer

36 Qty: **1x**

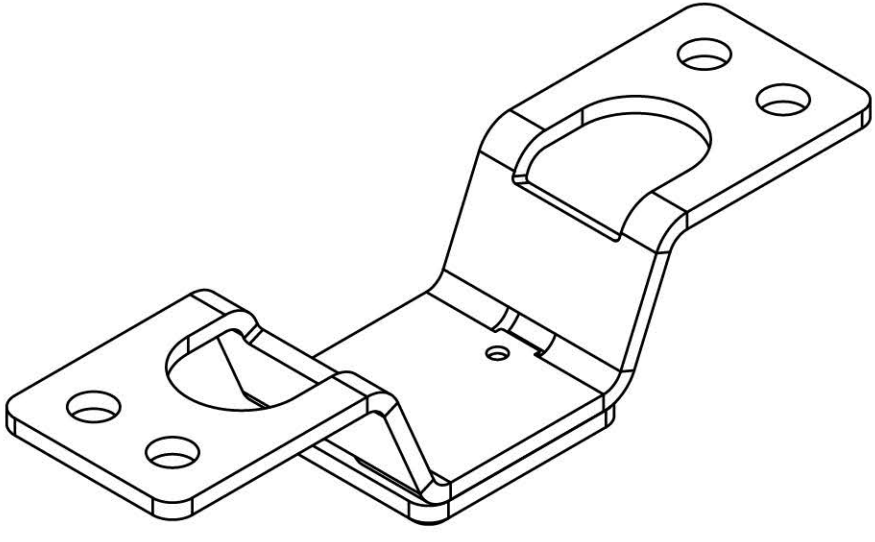

Top Weight Stack Stop Block

37 Qty: **2x**

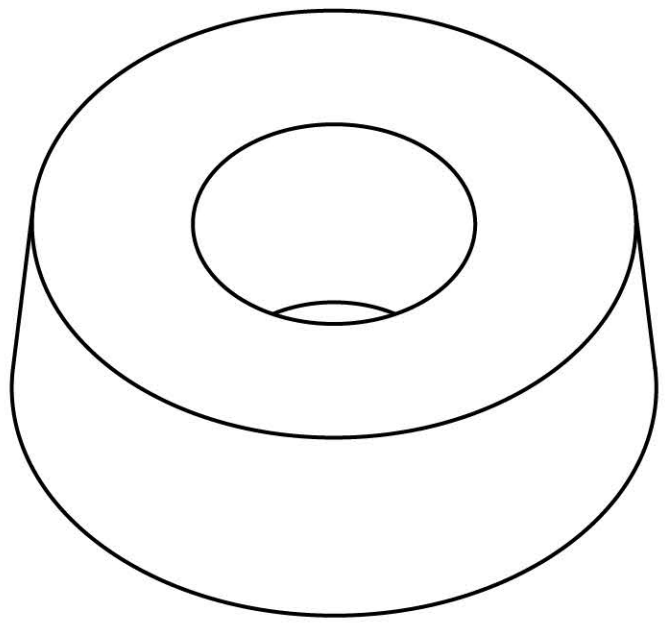

Weight Stack Bumper

38 Qty: **2x**

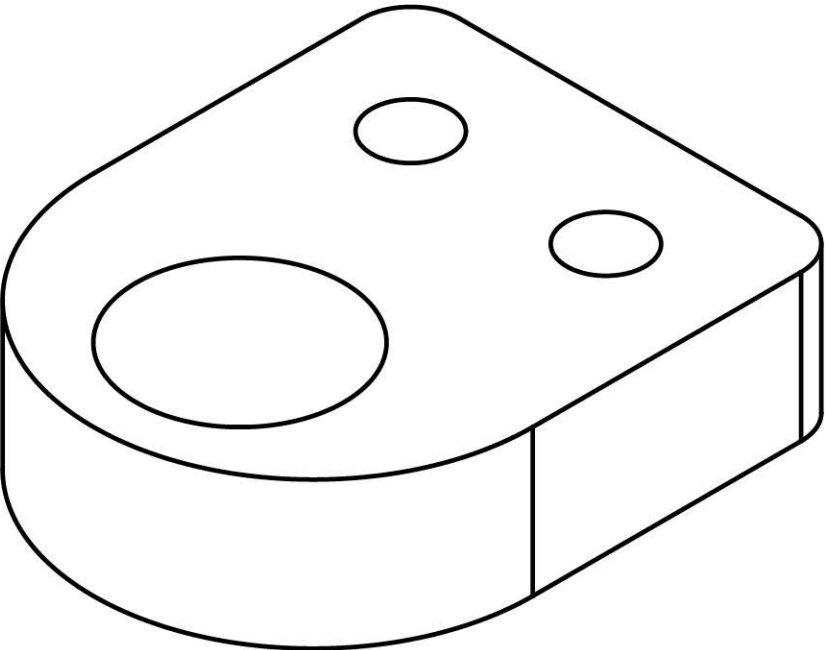

Guide Rod Spacer

39 Qty: **2x**

**

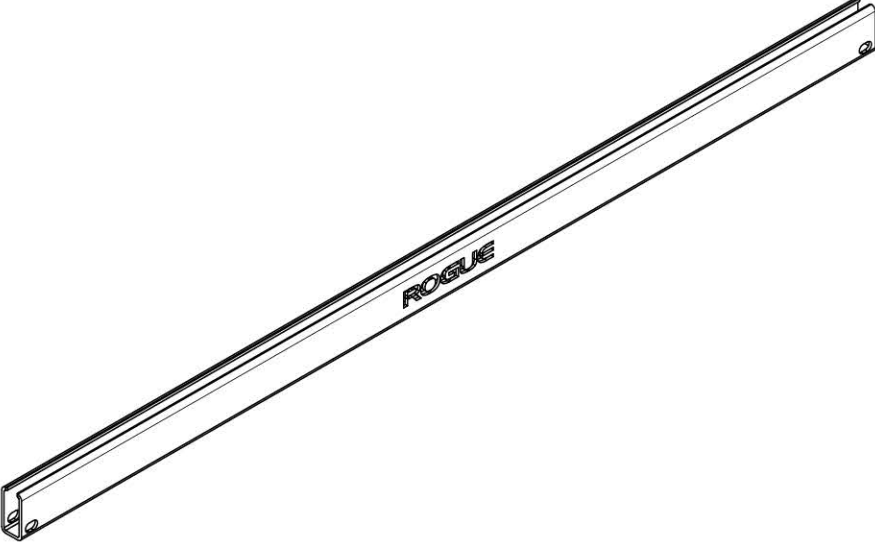

Top Cable Cover Rail (24", 30", or 43")

40 Qty: **2x**

**

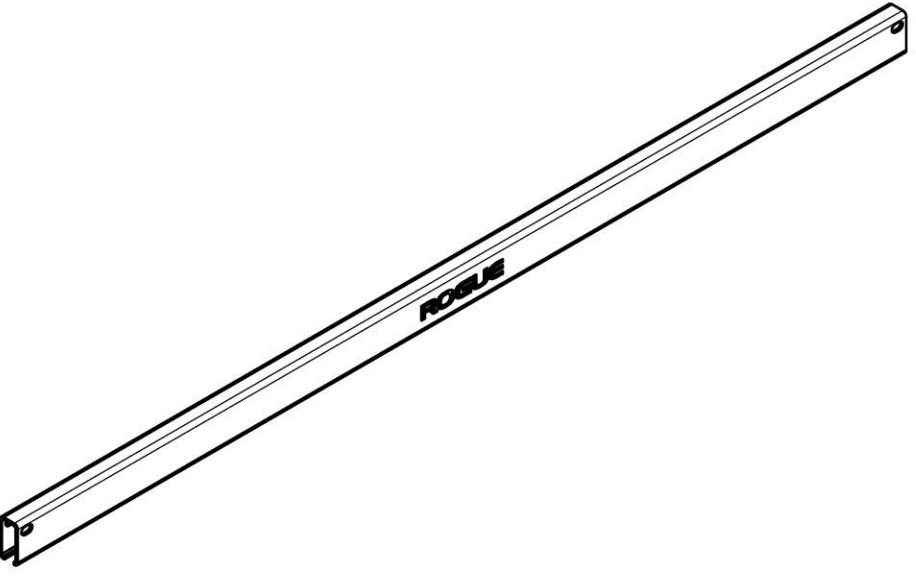

Low Cable Cover Rail (24", 30", or 43")

* Quantity depends on 250 lb or 300 lb weight stack selected at checkout.

** 24", 30", or 43" length depends on rack depth selection made at checkout.

INCLUDED PARTS: FM-6 ADD-ON KIT

Note: Images not shown at scale.

41 Qty: **1x**

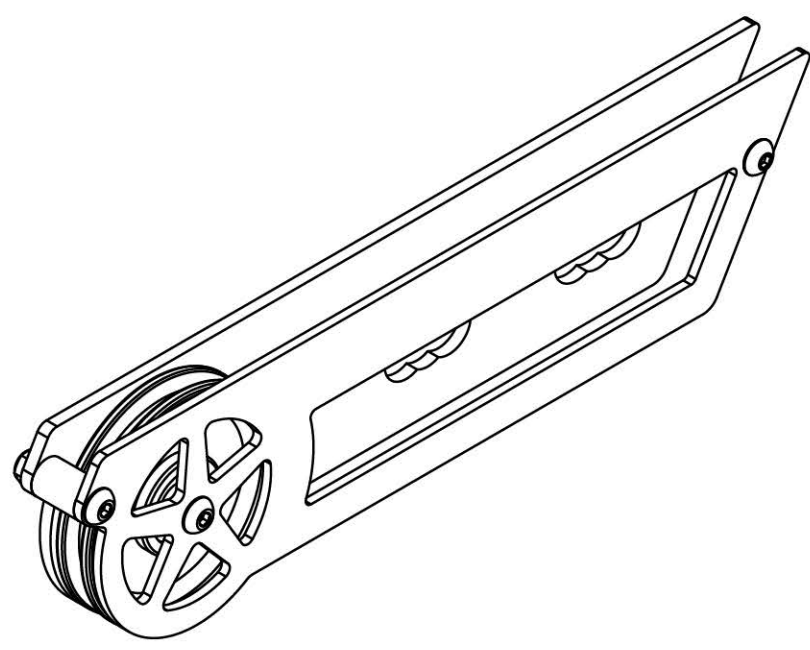

Top Front Side Pulley Assembly - RH

42 Qty: **1x**

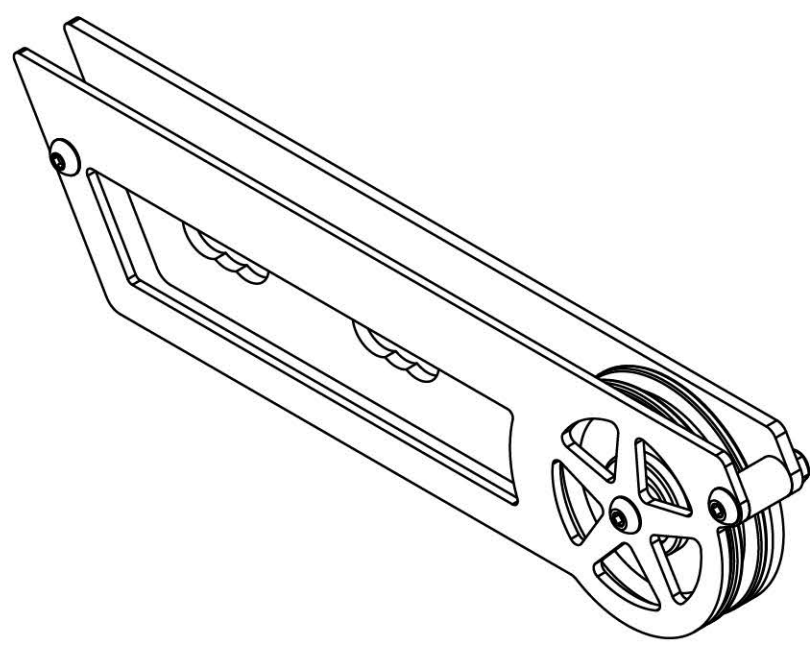

Top Front Side Pulley Assembly - LH

43 Qty: **1x**

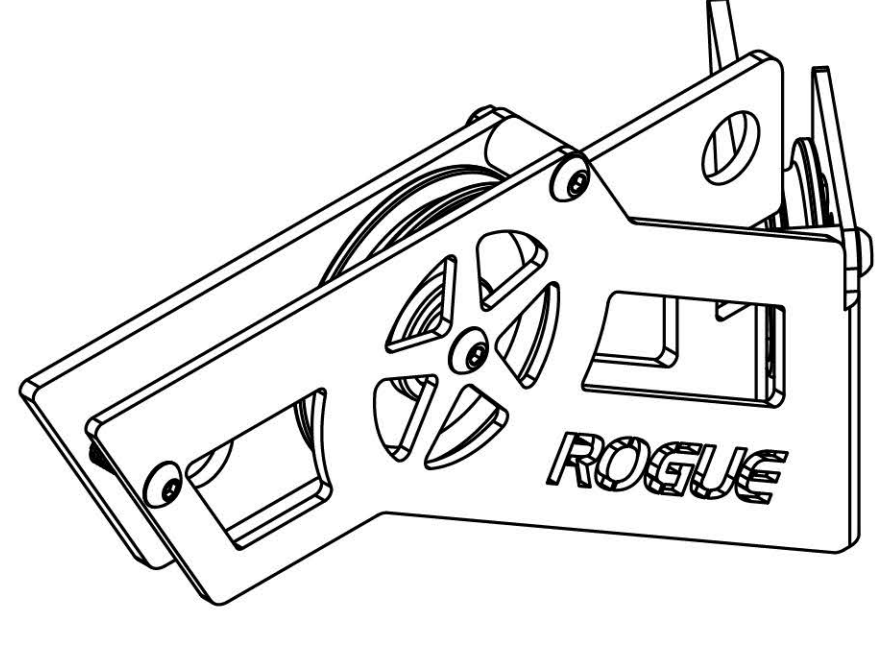

Top Rear Side Pulley Assembly - RH

44 Qty: **1x**

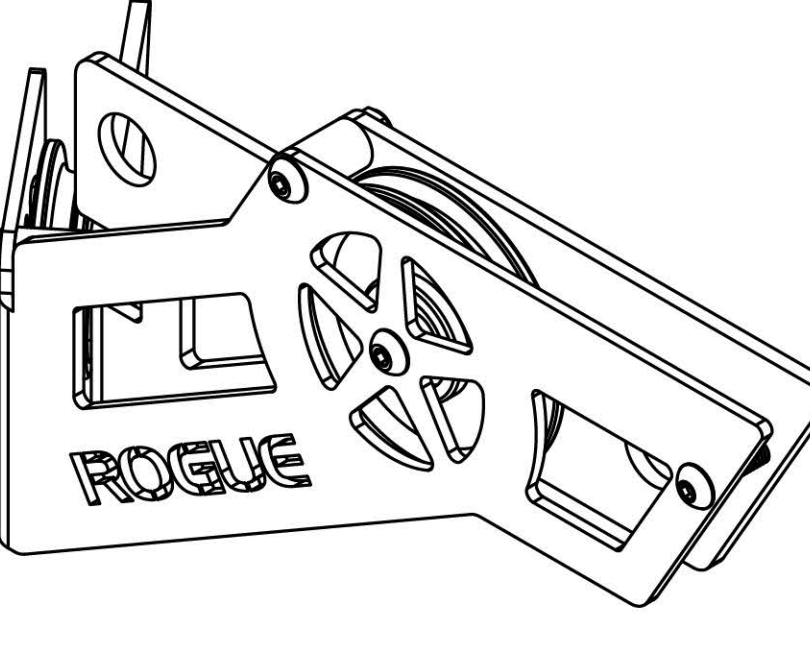

Top Rear Side Pulley Assembly - LH

45 Qty: **1x**

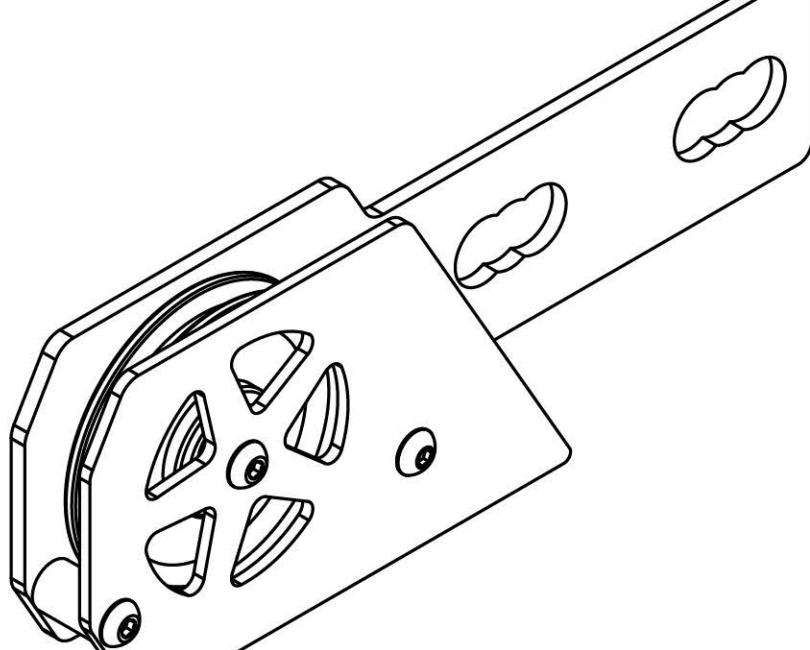

Bottom Front Side Pulley Assembly - RH

46 Qty: **1x**

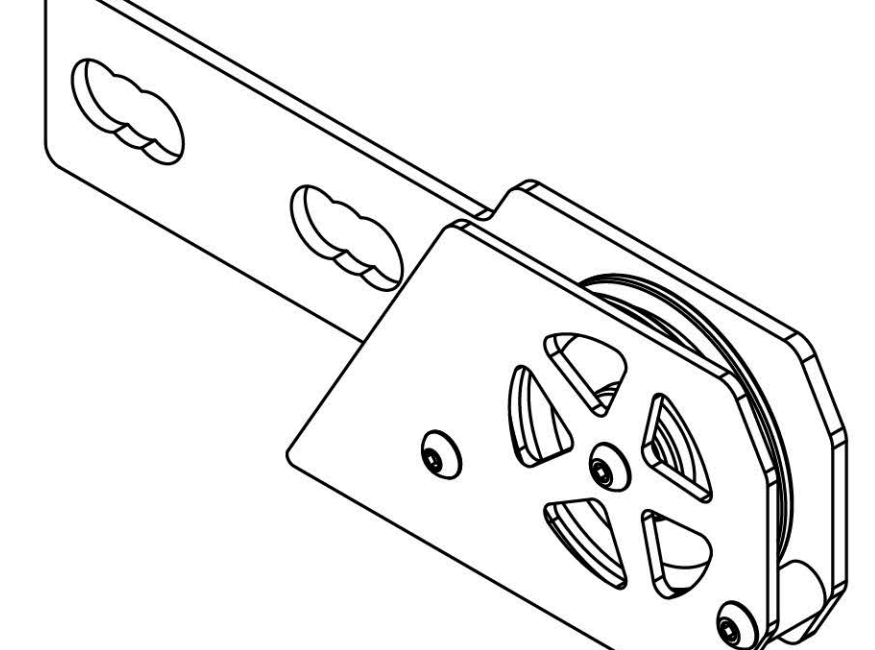

Bottom Front Side Pulley Assembly - LH

47 Qty: **1x**

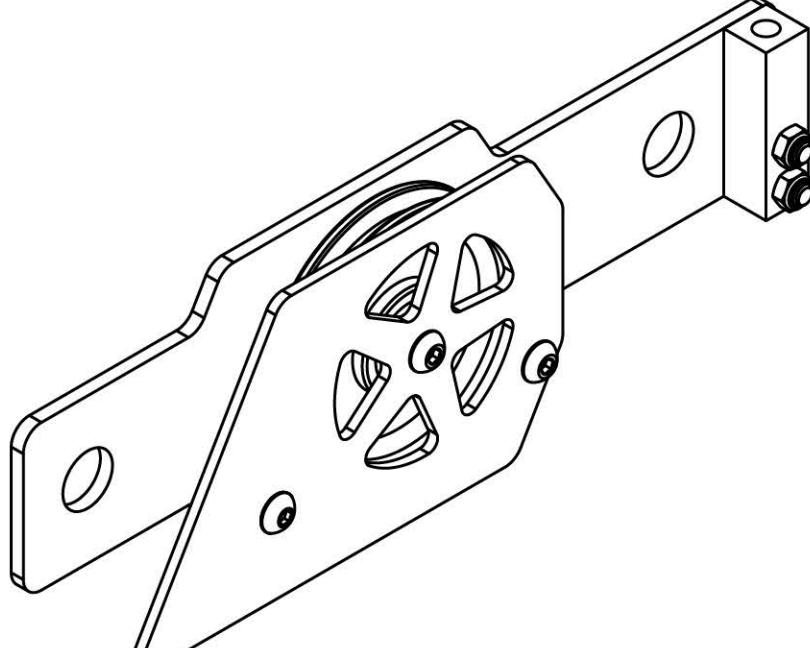

Bottom Rear Side Pulley Assembly - RH

48 Qty: **1x**

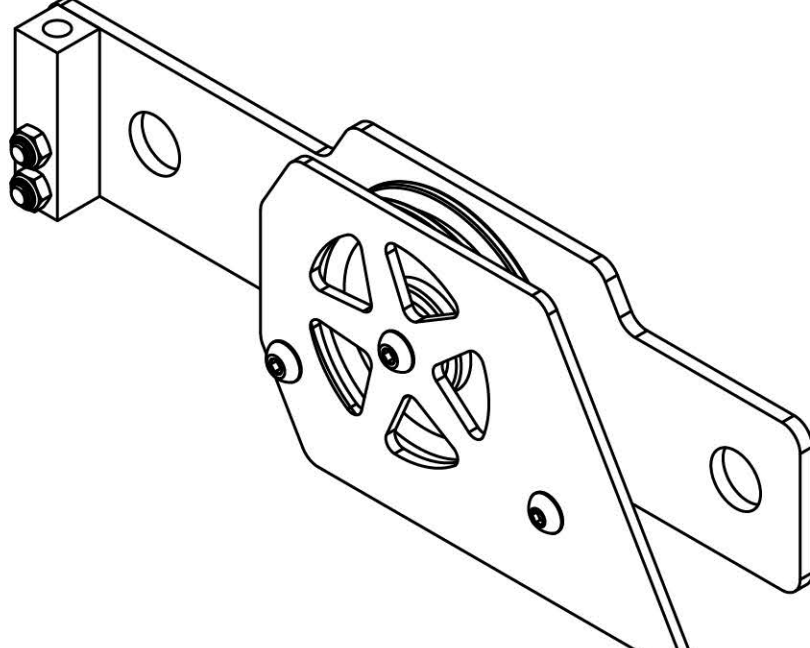

Bottom Rear Side Pulley Assembly - LH

49 Qty: **1x**

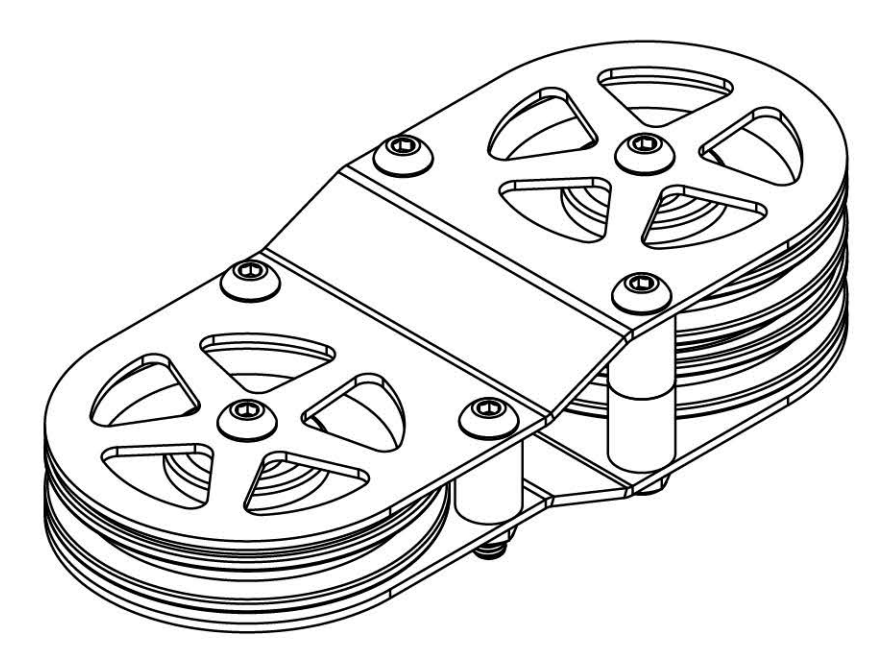

Rear Peanut Pulley

50 Qty: **2x**

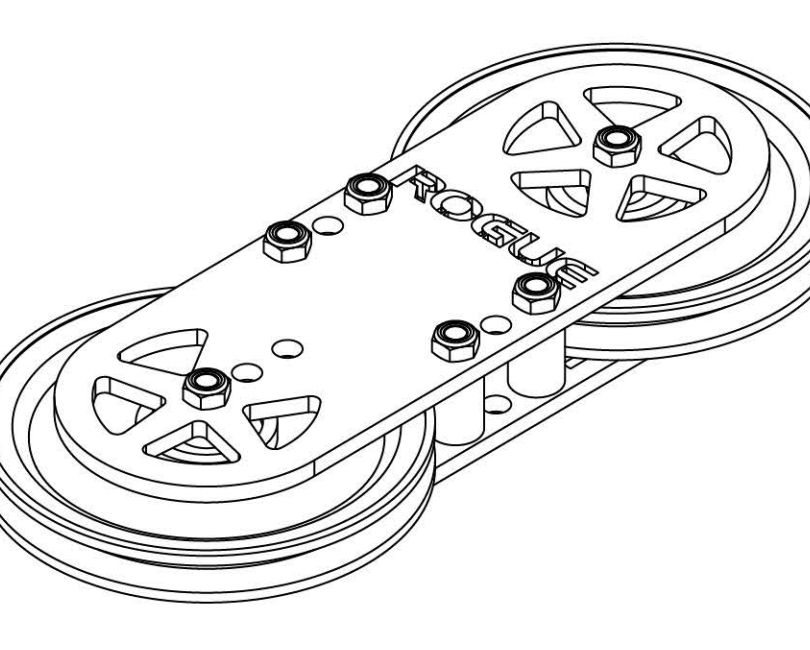

Side Peanut Pulley

51 Qty: **1x**

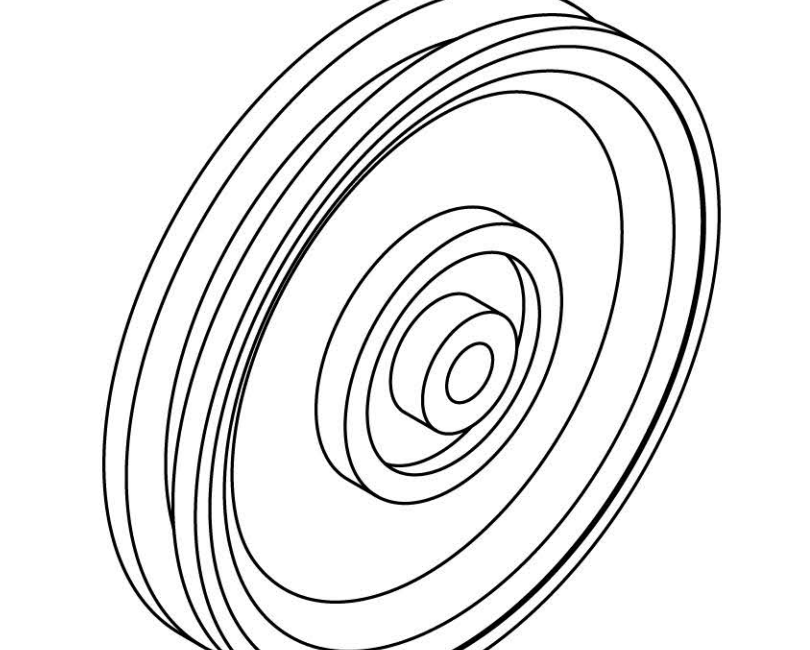

4.5" Pulley

52 Qty: **1x**

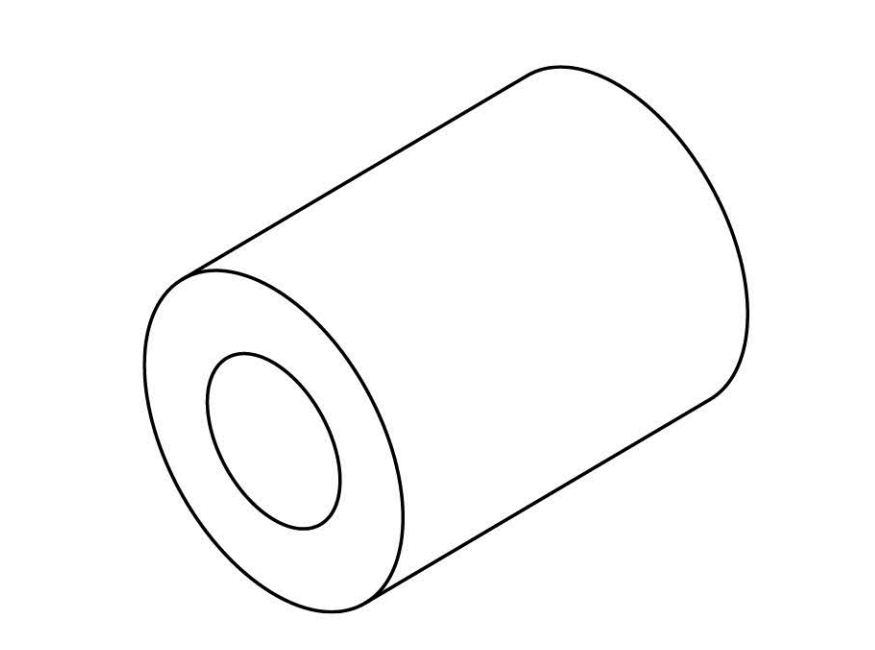

3/4" x 1" Cable Retainer

INCLUDED PARTS: FM-6 ADD-ON KIT

Note: Images not shown at scale.

53 Qty: **1x**

Trolley/Trolley Cable
(Blue Tag)

54 Qty: **1x**

*

Lat Pull/Low Row Cable
(Yellow Tag)

See Note*

55 Qty: **2x**

Low Side Cable
(Red Tag)

56 Qty: **1x**

10 LB. 4.50kg	85 LB. 38.6kg	20 LB. 9.10kg	170 LB. 77.3kg
15 LB. 6.80kg	90 LB. 40.8kg	30 LB. 13.6kg	180 LB. 81.6kg
20 LB. 9.10kg	95 LB. 43.1kg	40 LB. 18.2kg	190 LB. 86.4kg
25 LB. 11.3kg	100 LB. 45.5kg	50 LB. 22.7kg	200 LB. 90.9kg
30 LB. 13.6kg	105 LB. 47.6kg	60 LB. 27.2kg	210 LB. 95.3kg
35 LB. 15.9kg	110 LB. 50.0kg	70 LB. 31.8kg	220 LB. 100.0kg
40 LB. 18.2kg	115 LB. 52.2kg	80 LB. 36.4kg	230 LB. 104.5kg
45 LB. 20.4kg	120 LB. 54.5kg	90 LB. 40.9kg	240 LB. 109.1kg
50 LB. 22.7kg	125 LB. 56.7kg	100 LB. 45.5kg	250 LB. 113.6kg
55 LB. 24.9kg	130 LB. 59.1kg	110 LB. 50.0kg	260 LB. 118.2kg
60 LB. 27.2kg	135 LB. 61.2kg	120 LB. 54.5kg	270 LB. 122.7kg
65 LB. 29.5kg	140 LB. 63.5kg	130 LB. 59.1kg	280 LB. 127.3kg
70 LB. 31.8kg	145 LB. 65.8kg	140 LB. 63.5kg	290 LB. 131.8kg
75 LB. 34.1kg	150 LB. 68.2kg	150 LB. 68.2kg	300 LB. 136.4kg
80 LB. 36.4kg	160 LB. 72.7kg		

Weight Stack Number
Label Sheet

57 Qty: **8x**

Plate Storage Spacer

58 Qty: **1x**

Stainless Lat Bar

59 Qty: **1x**

Standard Grip Triangle

60 Qty: **2x**

Single Handle Cable Attachment

61 Qty: **2x**

D Carabiner

62 Qty: **2x**

1" Shoulder Bolt -
Female

63 Qty: **2x**

1" Shoulder Bolt - Male

64 Qty: **20x**

1" x 5" Hex Bolt

* Extra "retainer" hardware shown is not included on Lat Pull/Low Row Cable for 90" Racks.

INCLUDED PARTS: FM-6 ADD-ON KIT

Note: Images not shown at scale.

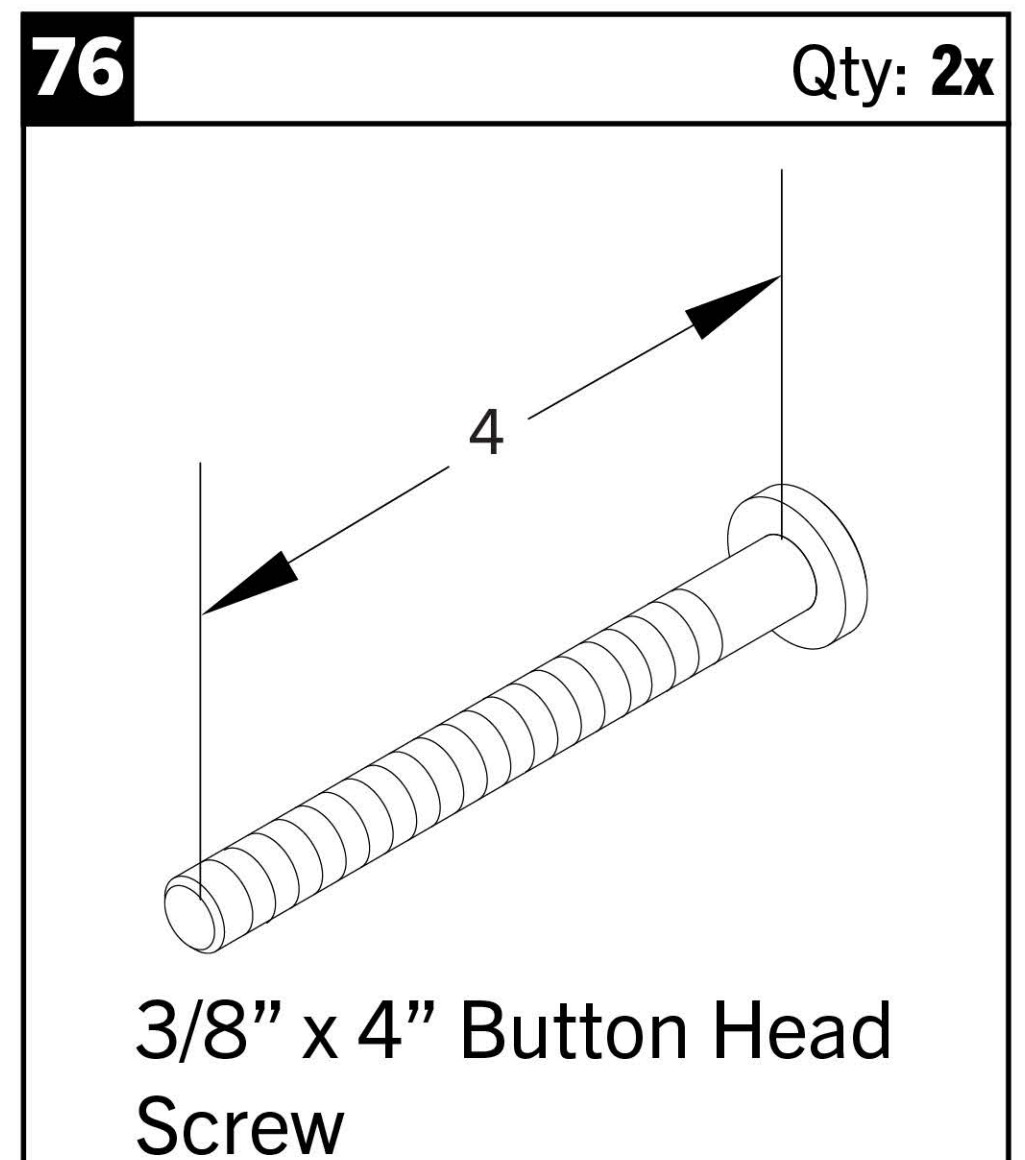
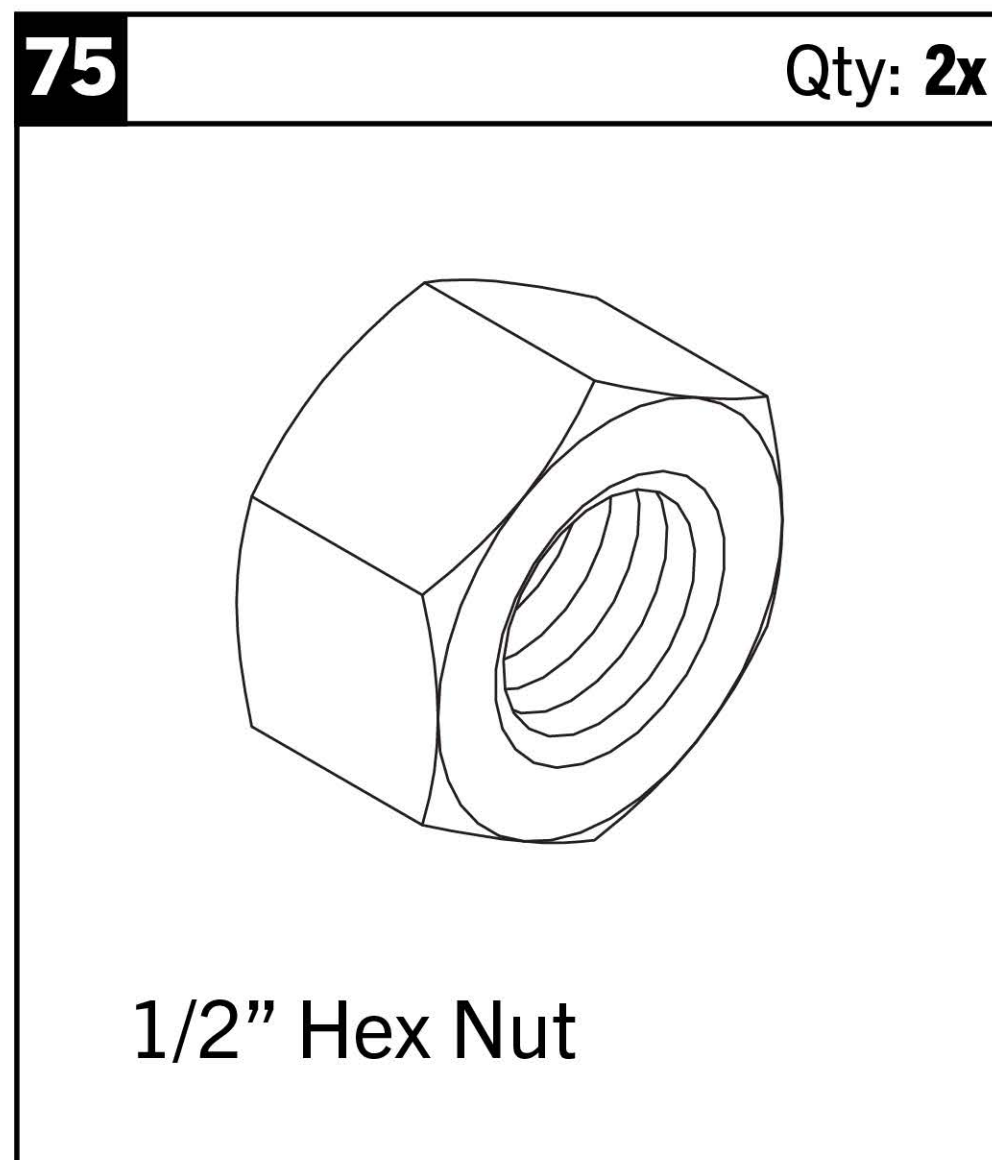
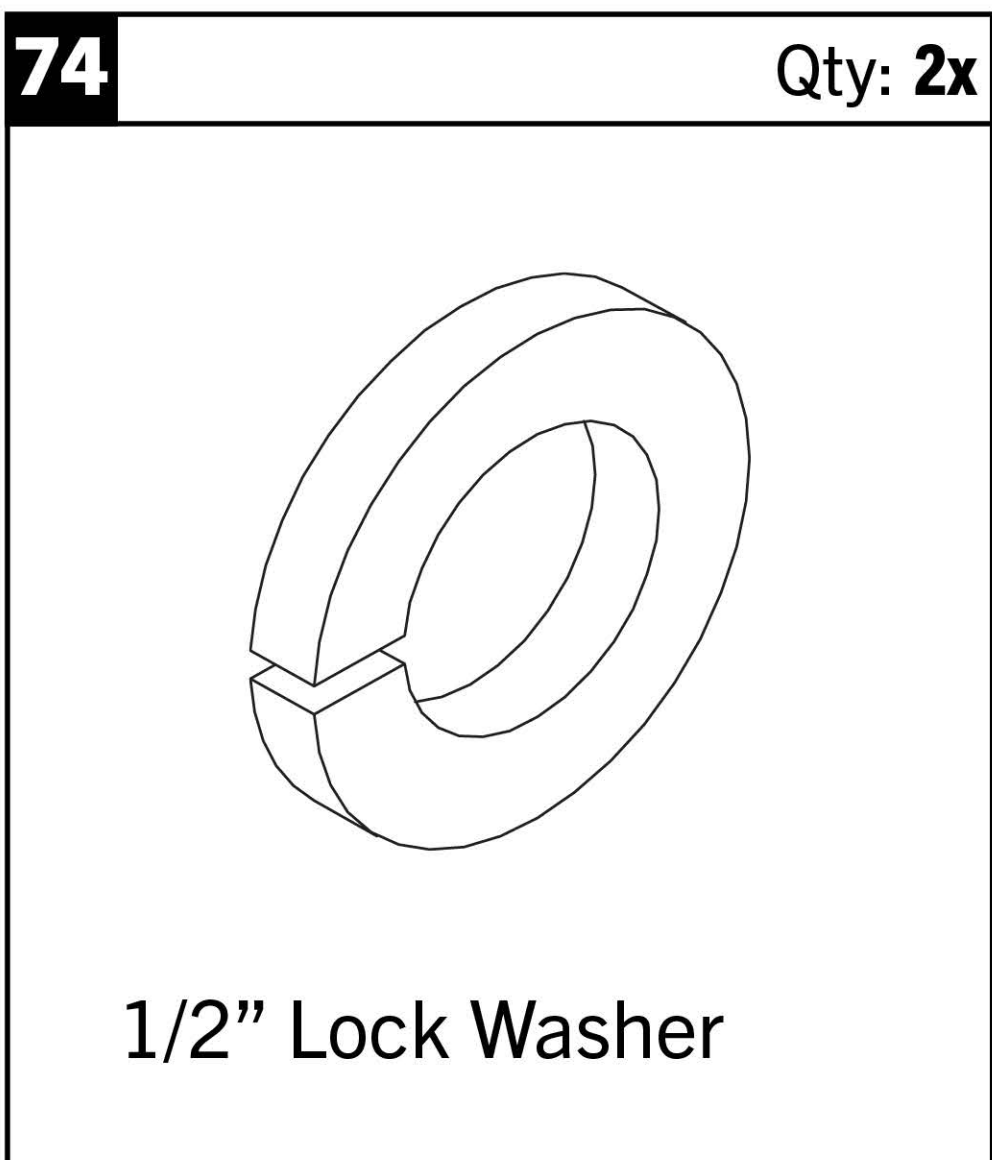
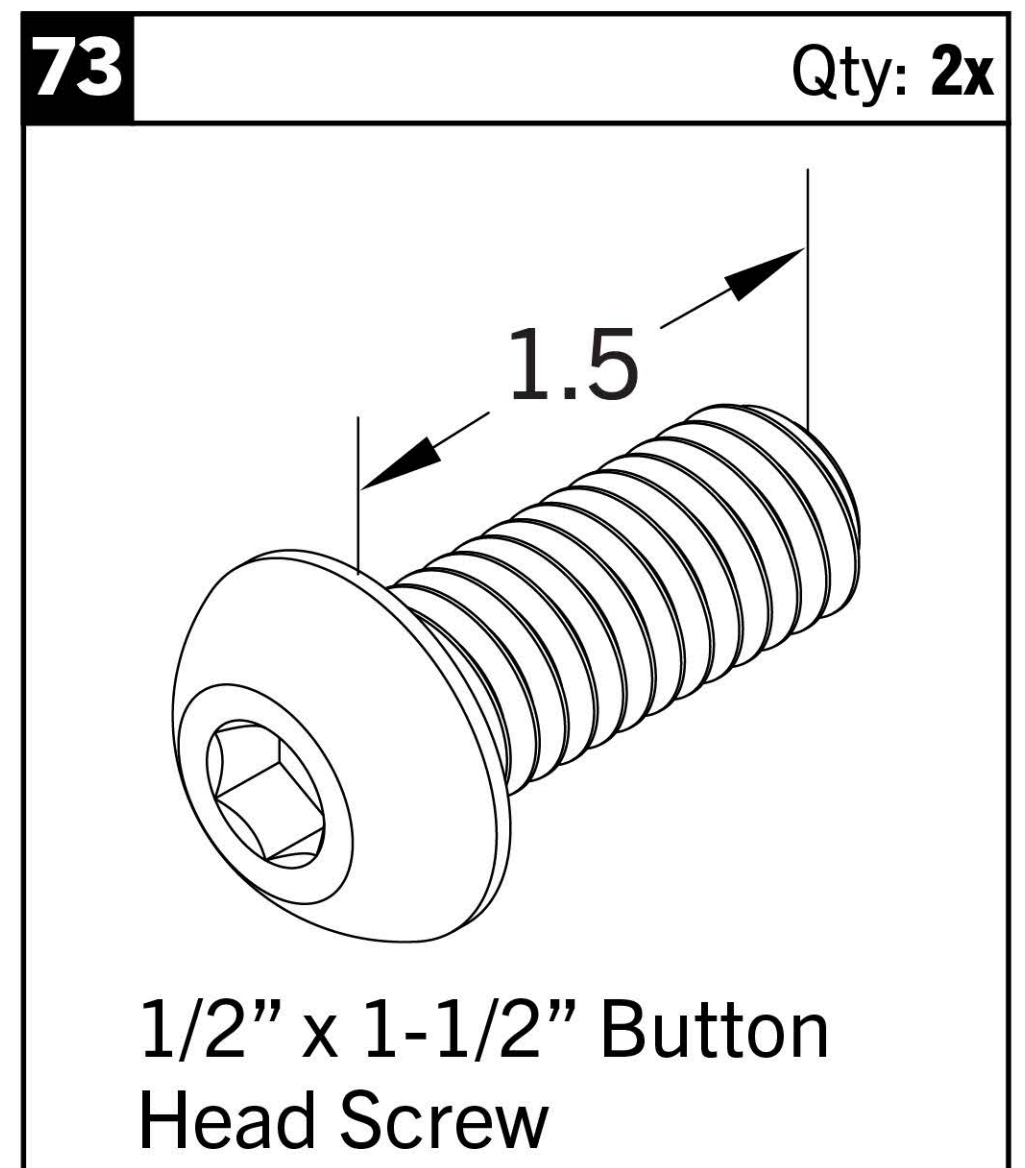
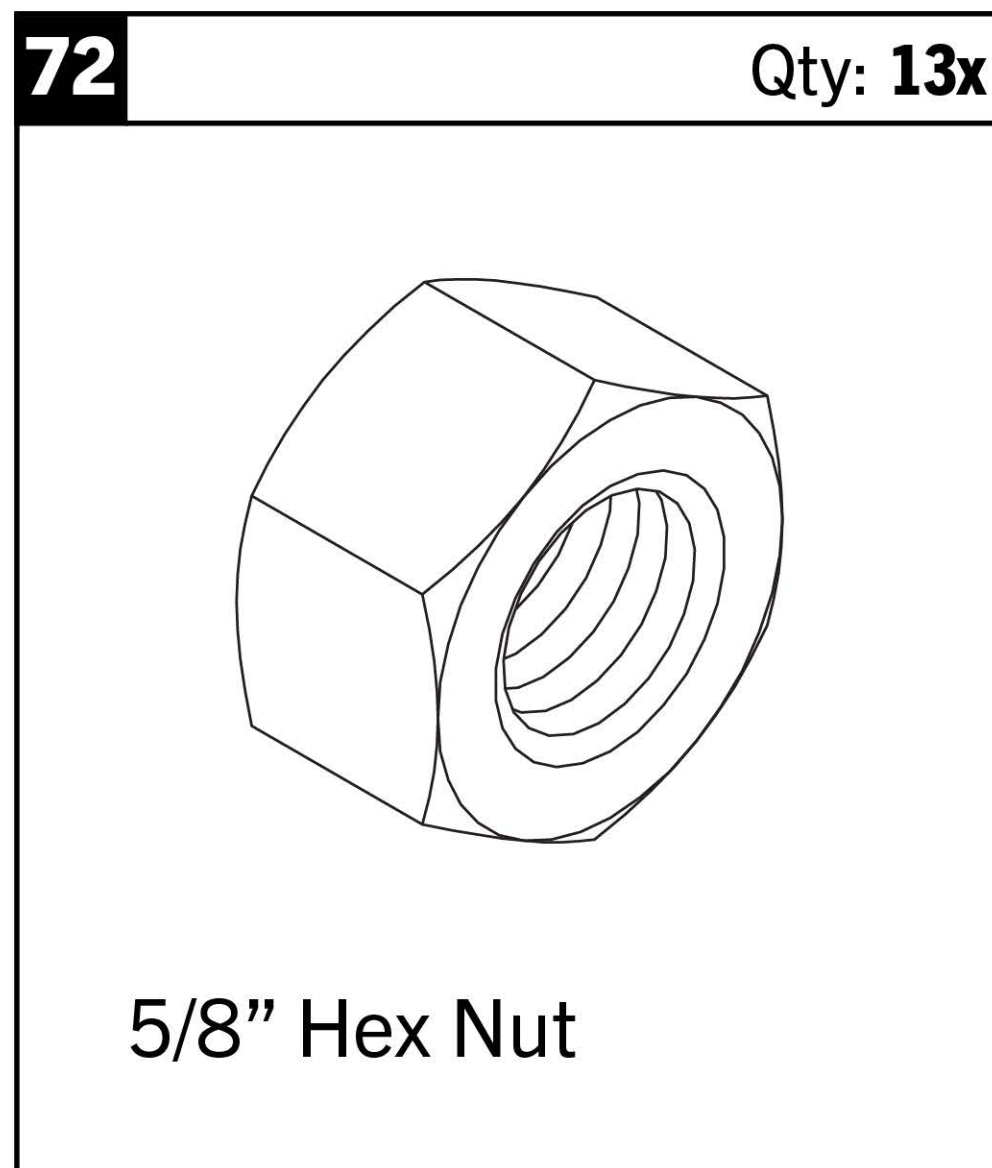
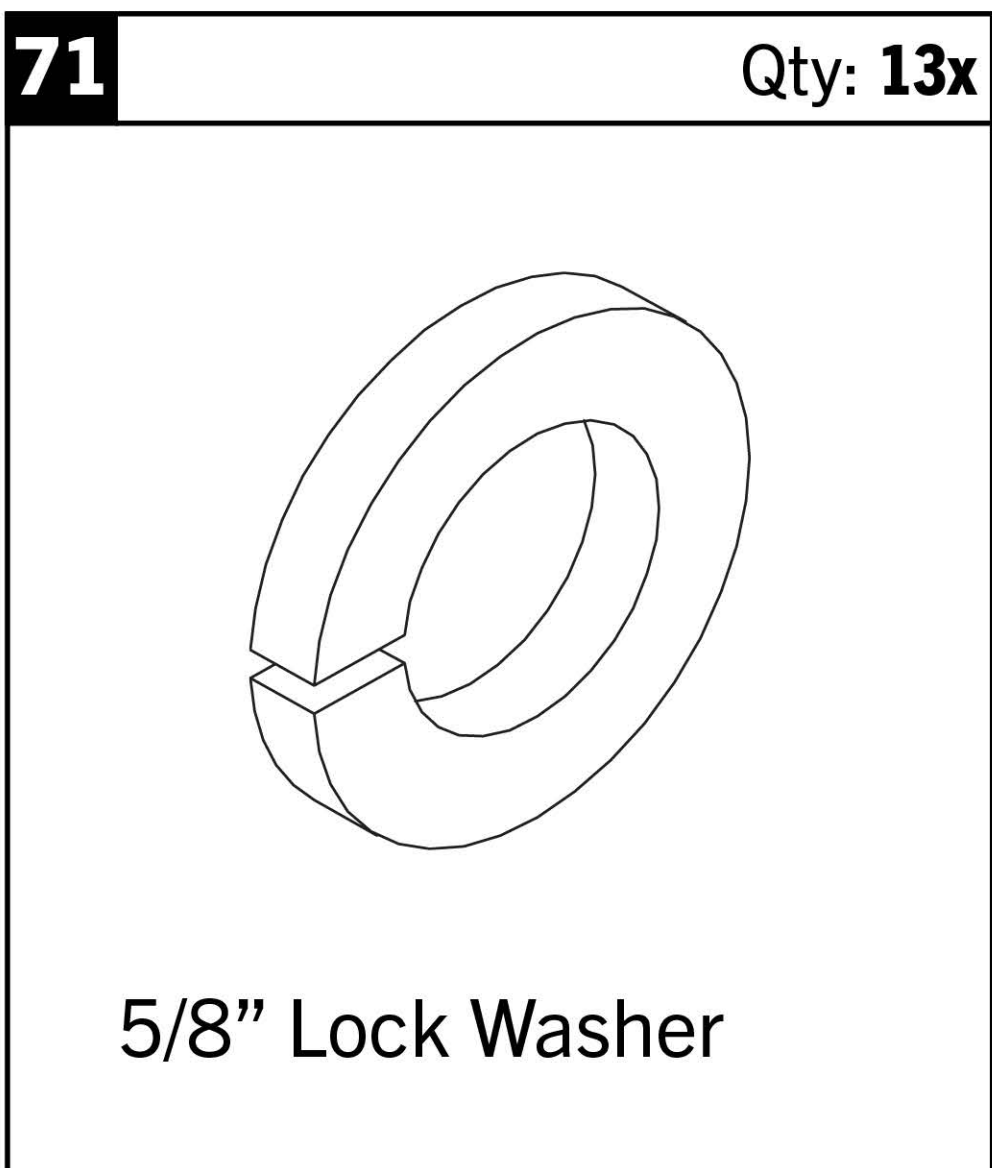
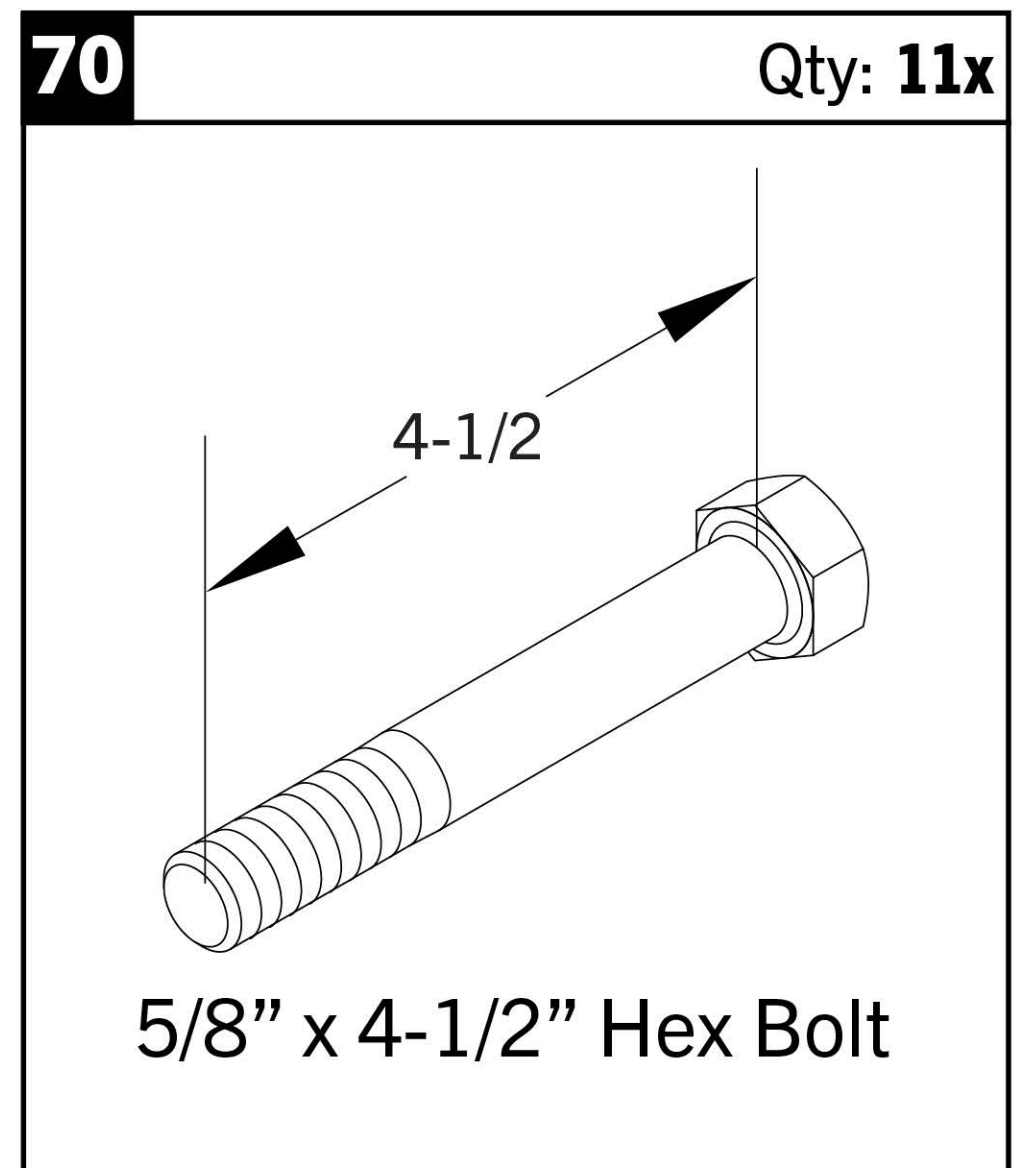
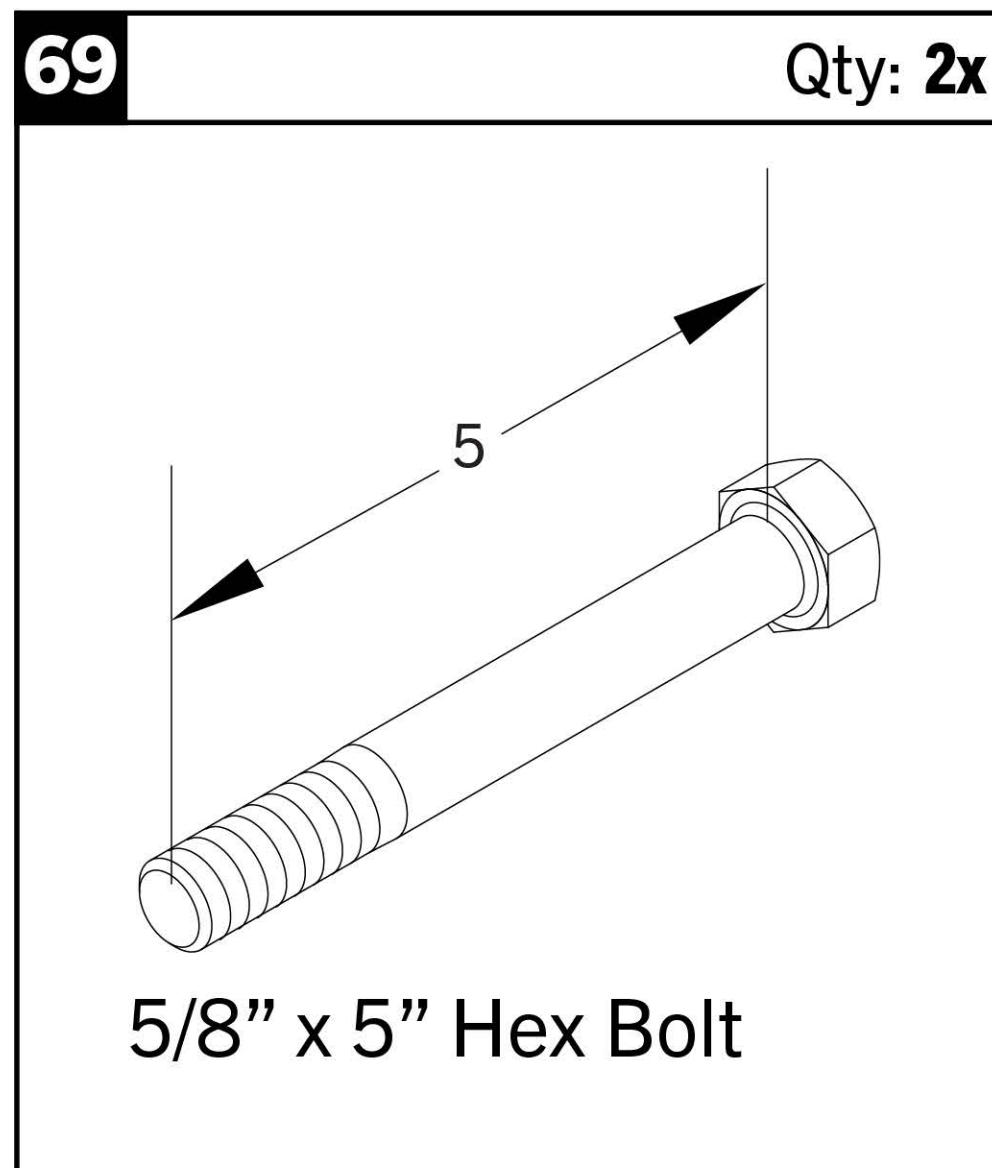
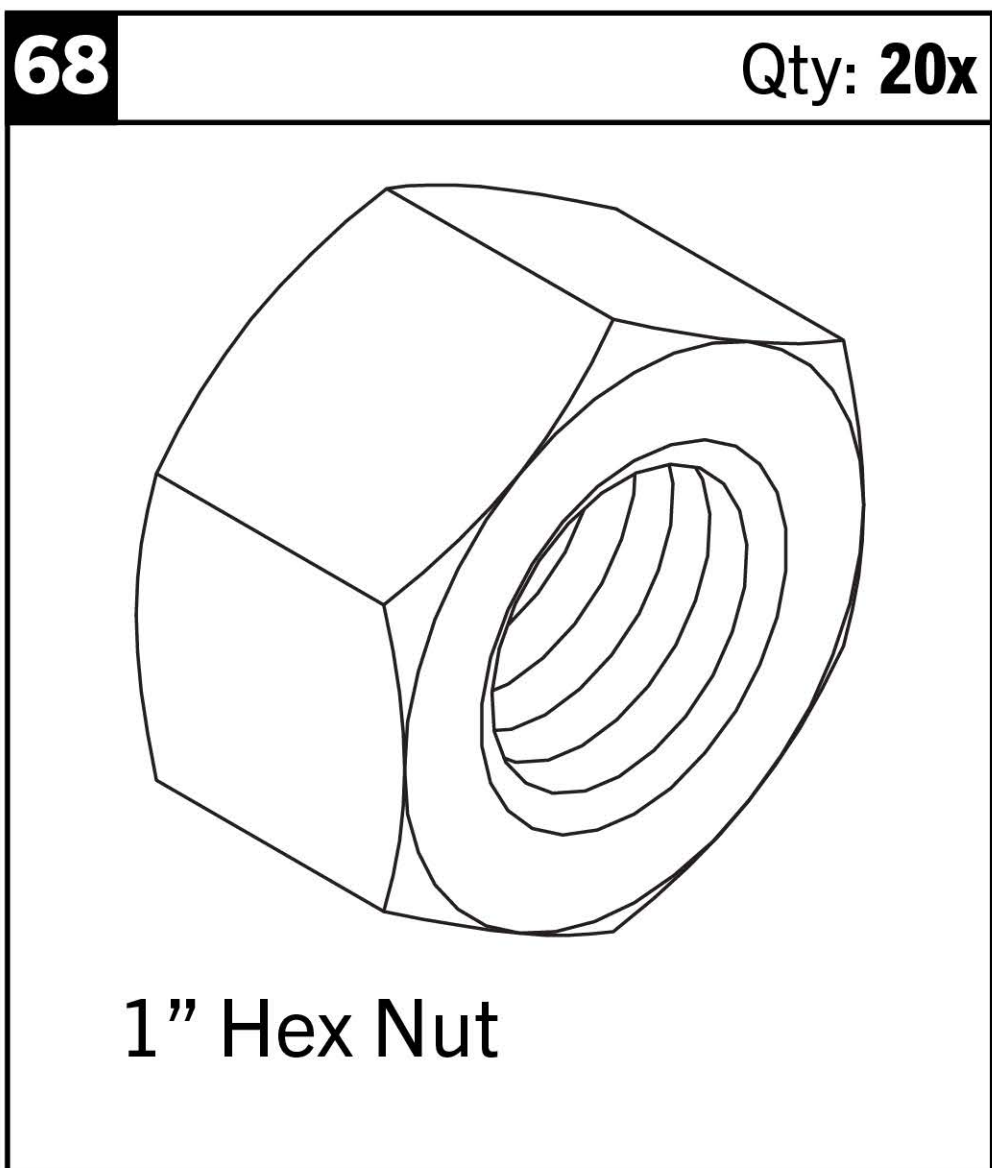
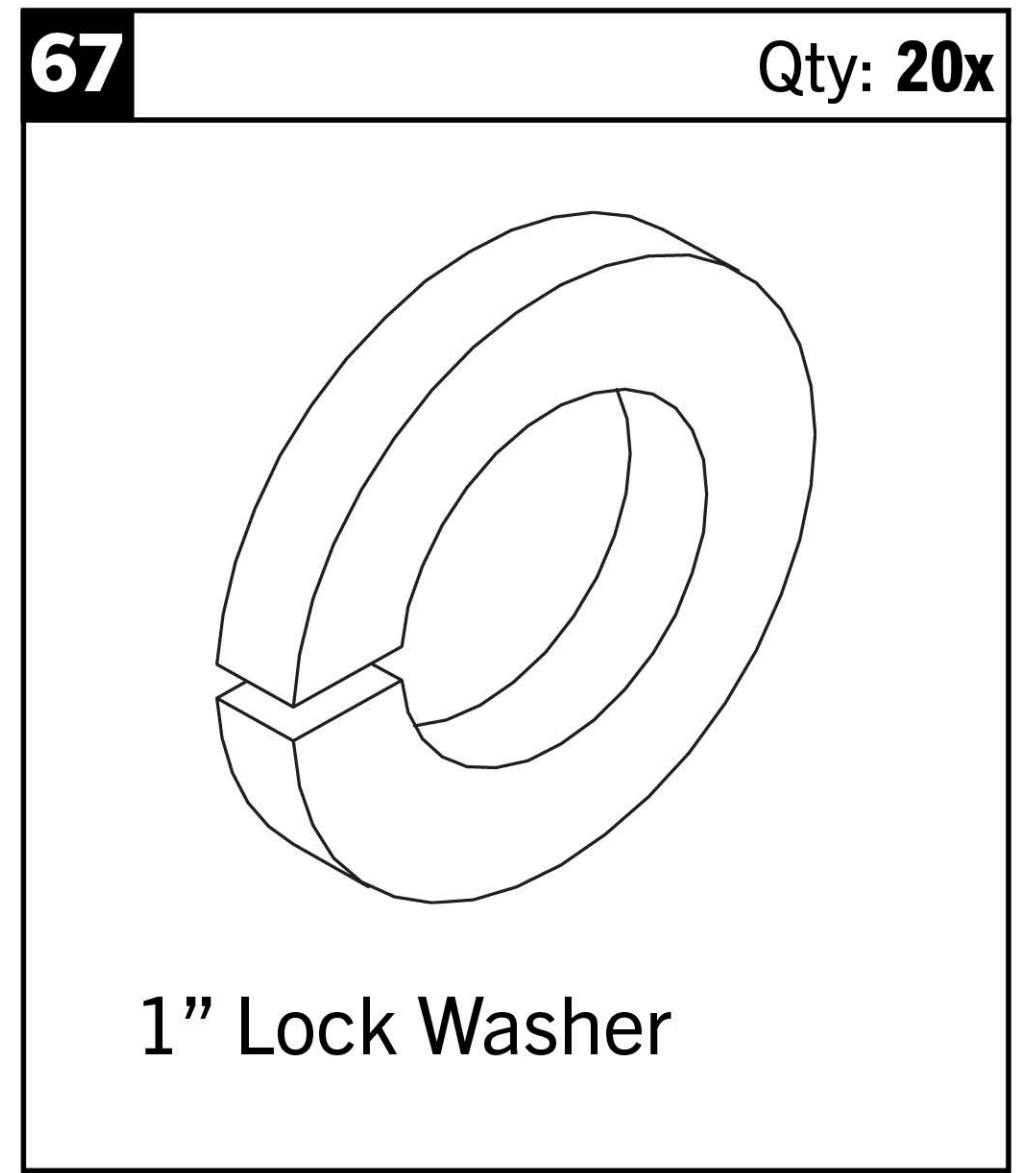
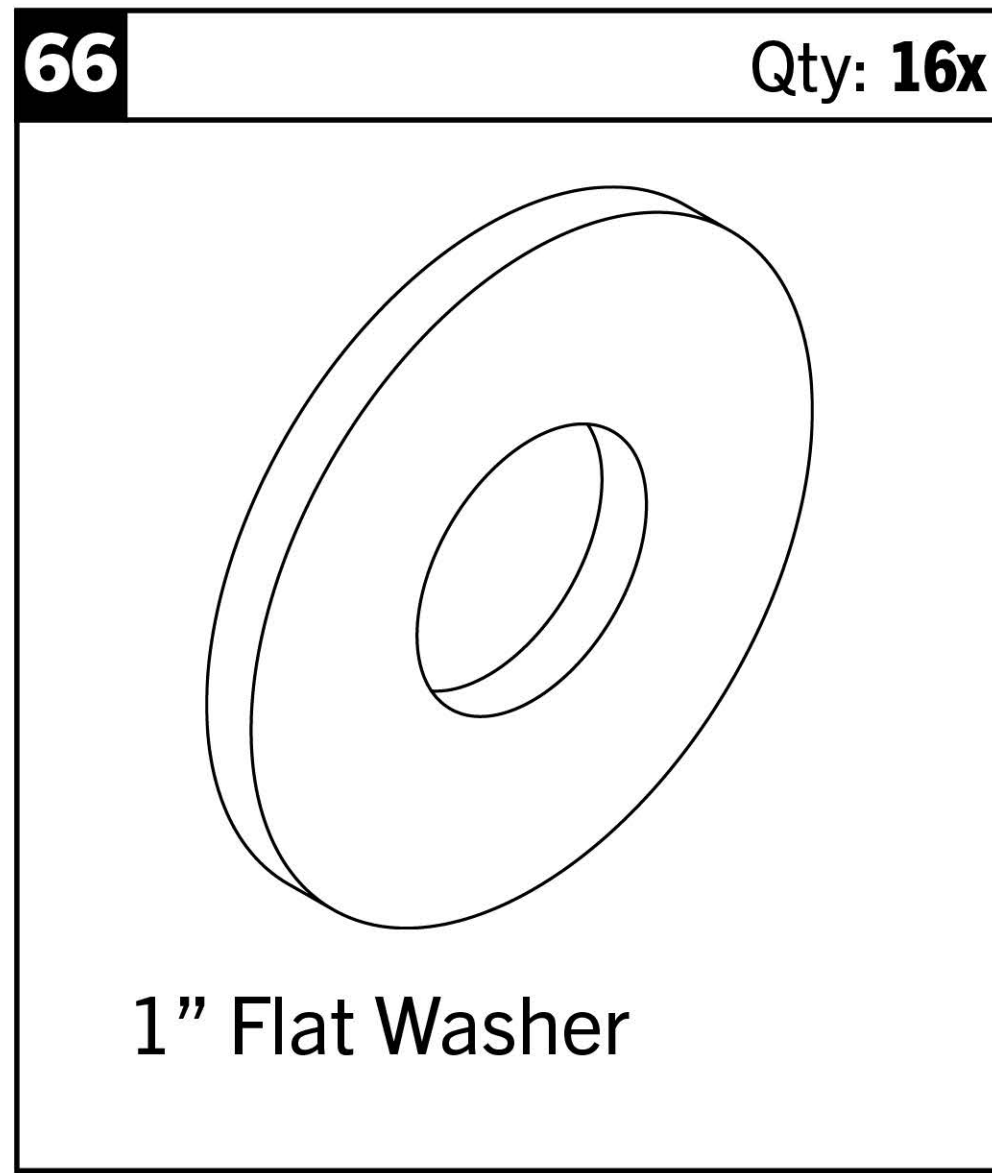
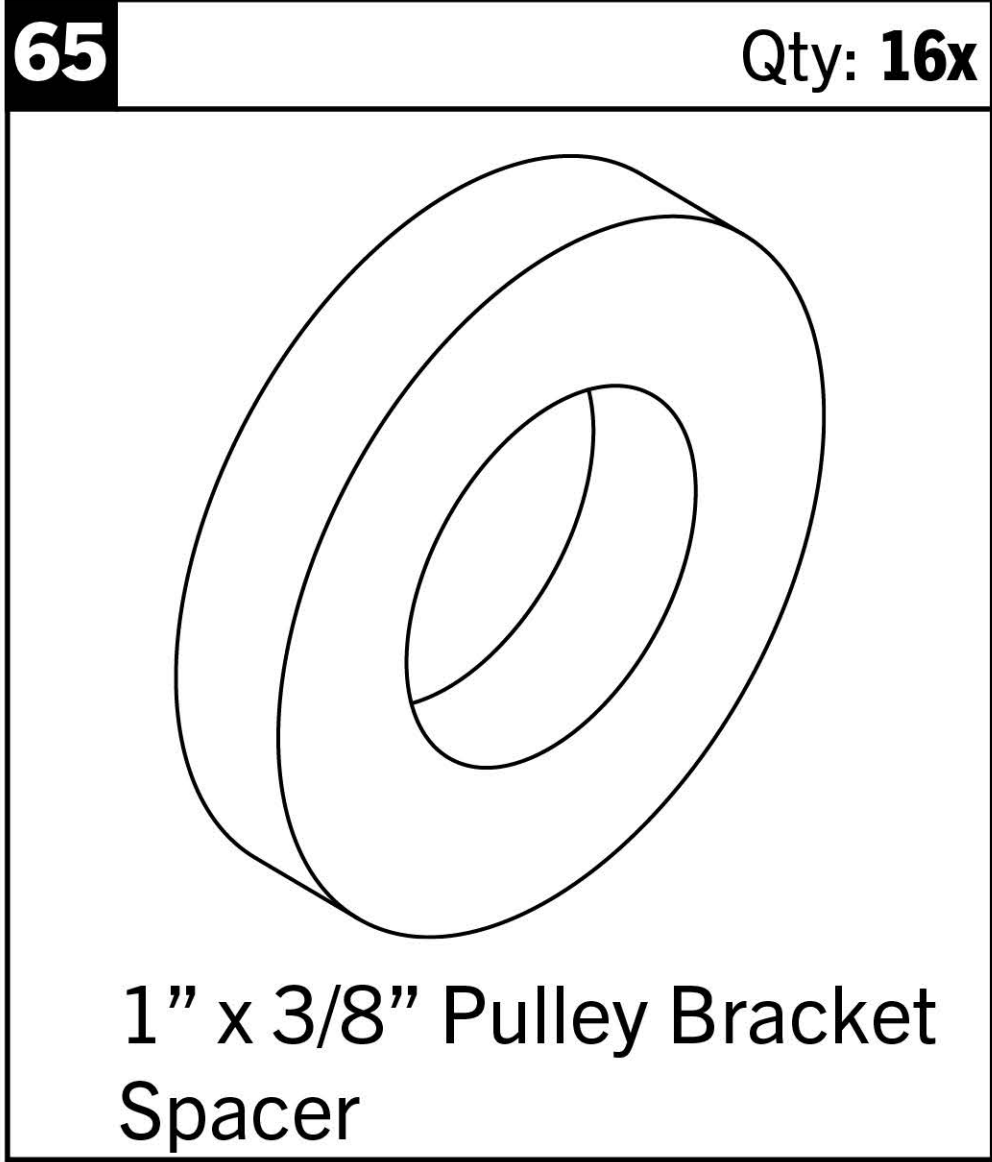

INCLUDED PARTS: FM-6 ADD-ON KIT

Note: Images not shown at scale.

77 Qty: **4x**

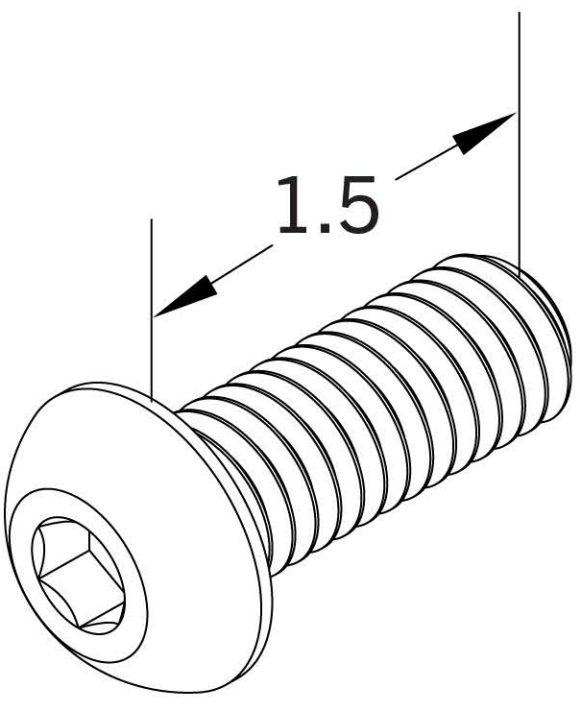

3/8" x 1.5" Button Head Screw

A technical drawing of a button head screw. The drawing shows the hexagonal head and the threaded shaft. A dimension line with arrows at both ends indicates the length of the threaded portion, which is labeled as 1.5.

78 Qty: **6x**



3/8" Thin Nylock Nut

A technical drawing of a thin nylock nut, showing its hexagonal shape and the internal threads.

79 Qty: **2x**

*

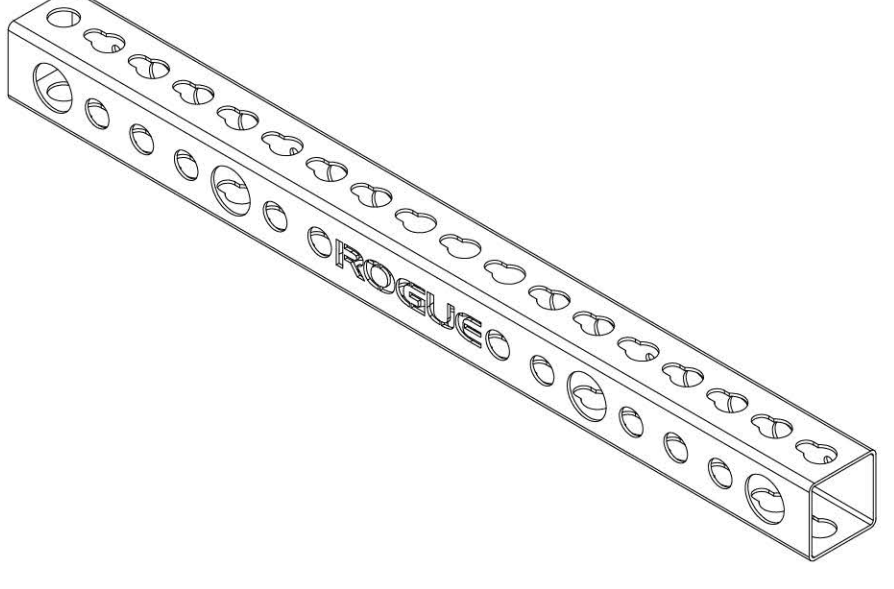

Monster Strip

A technical drawing of a long, thin metal strip with a series of circular holes along its length. The word "OROGUE" is visible on the side of the strip.

INCLUDED PARTS: SHROUD KIT

Note: Images not shown at scale.

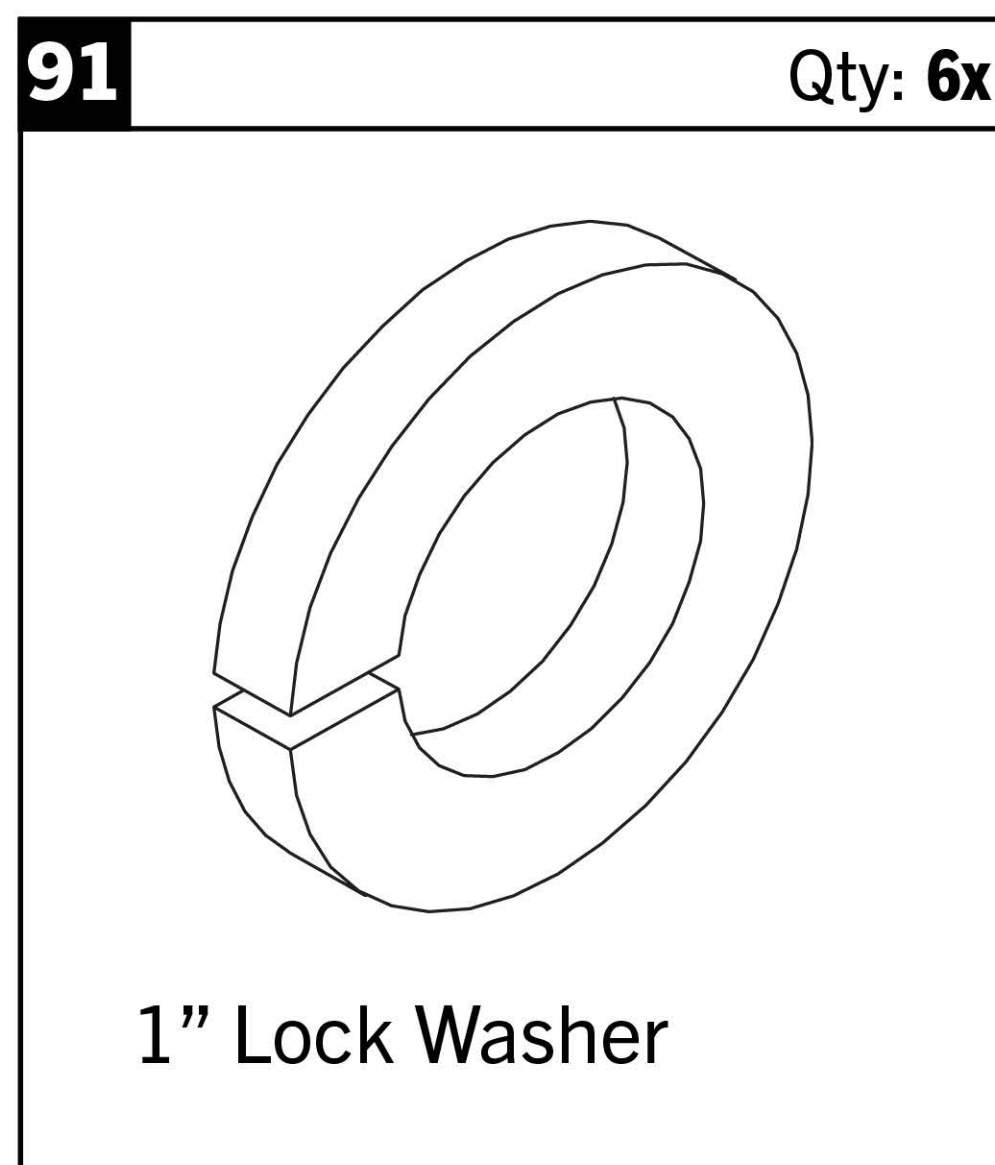
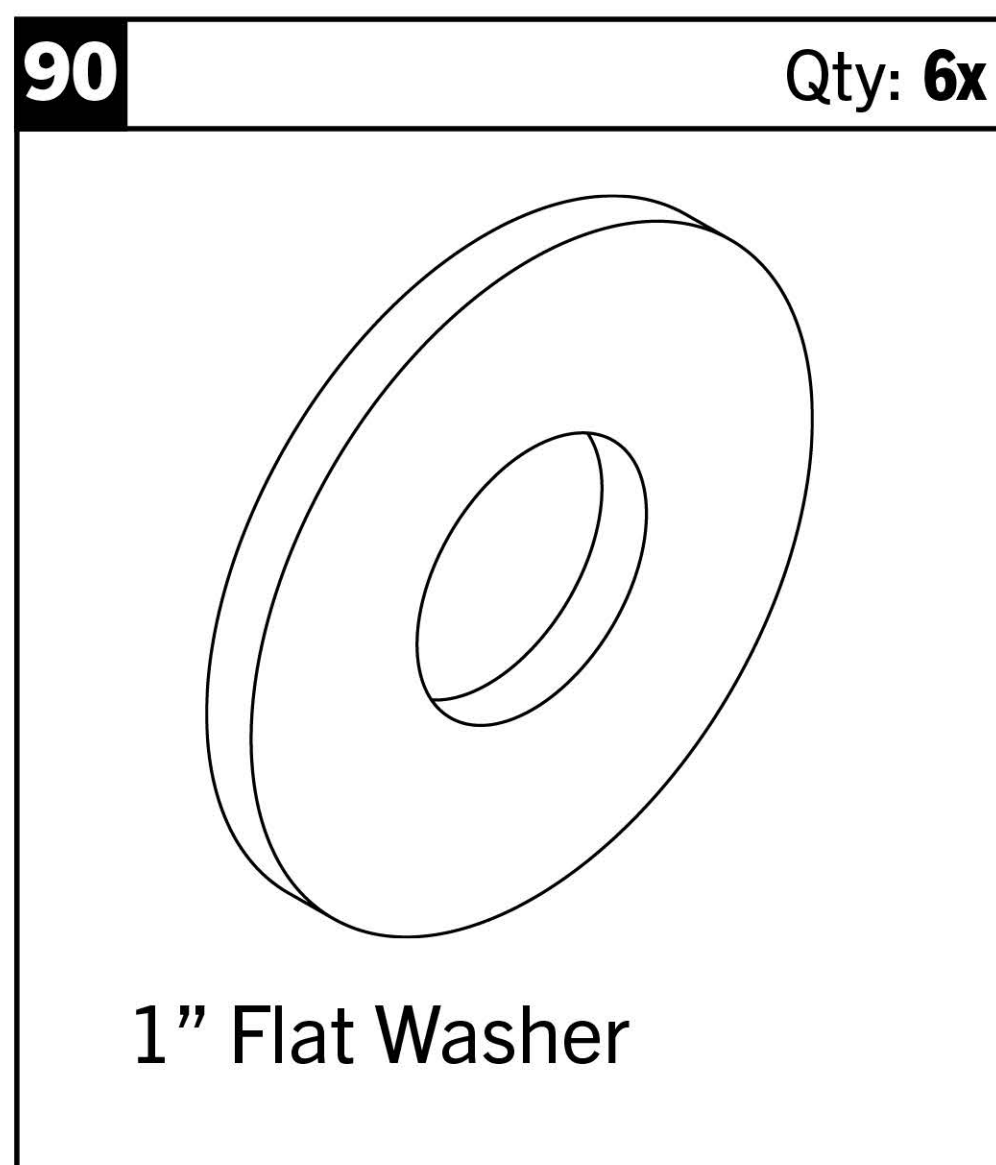
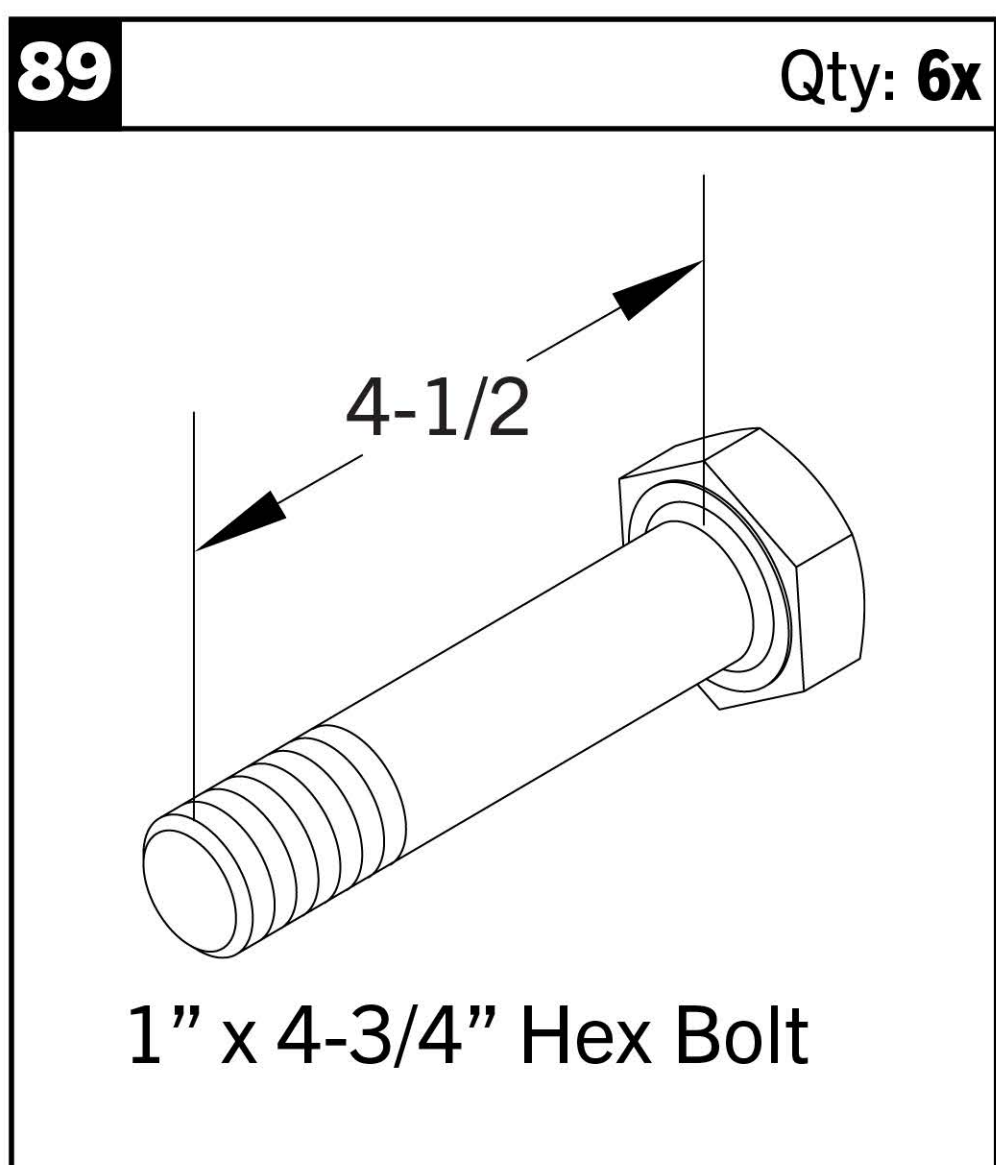
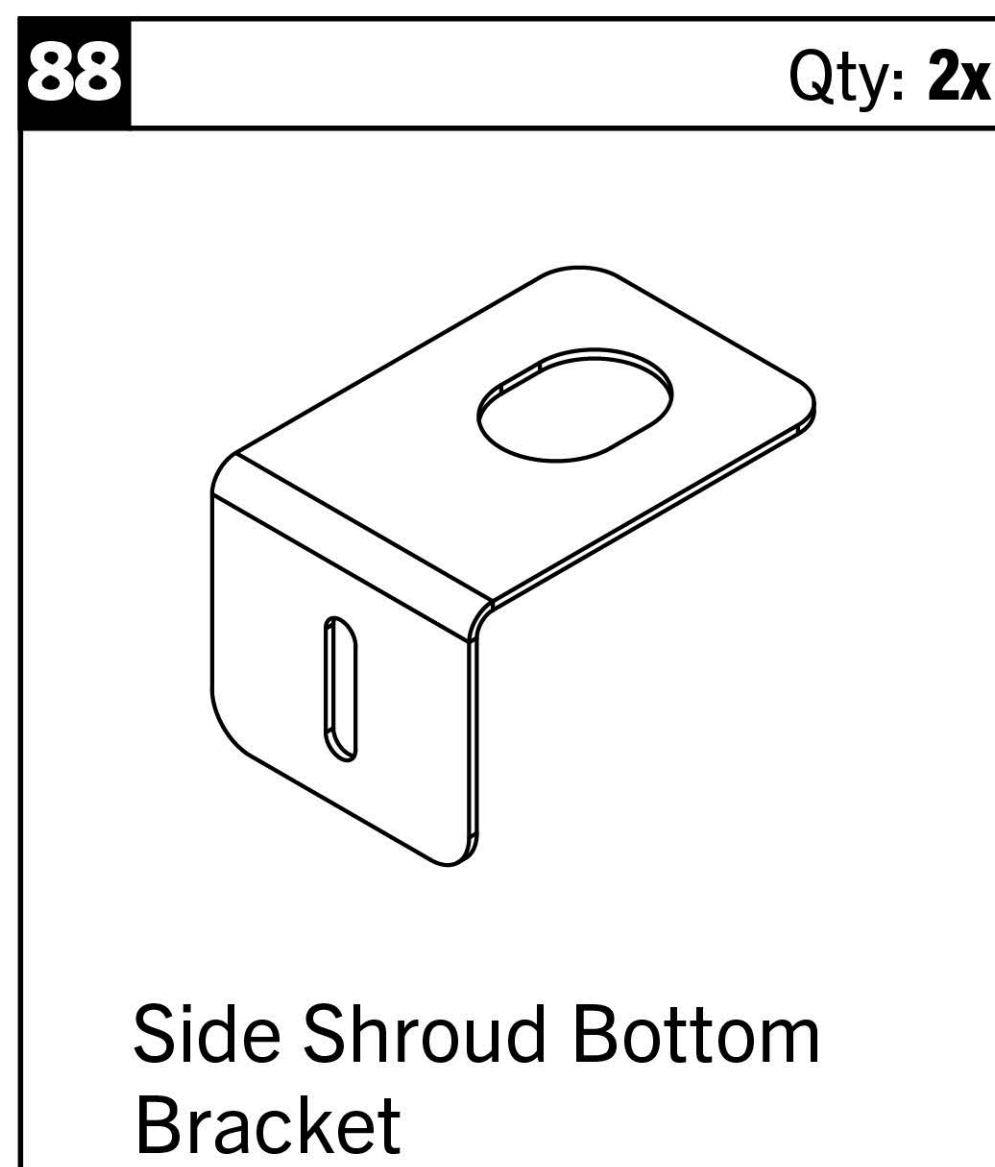
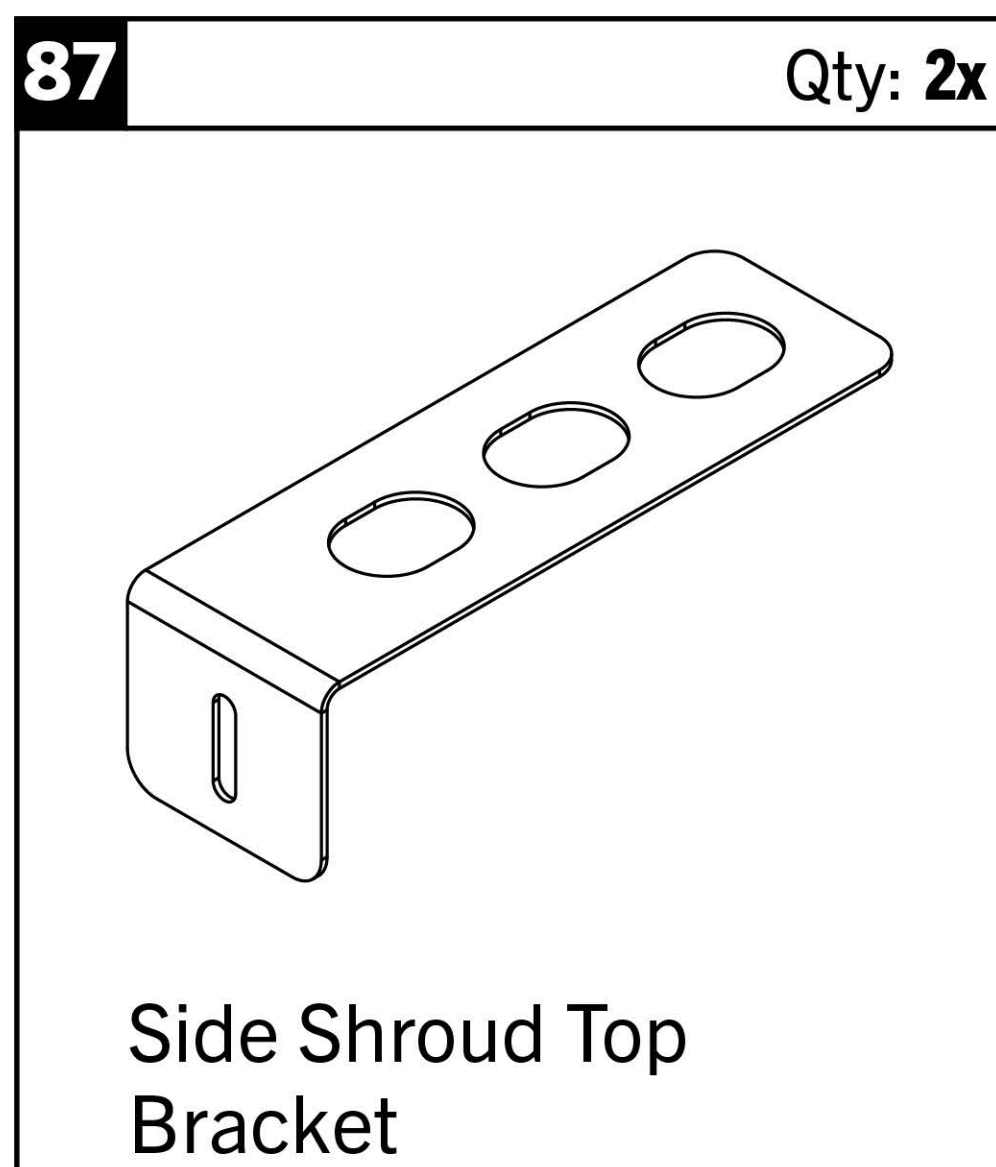
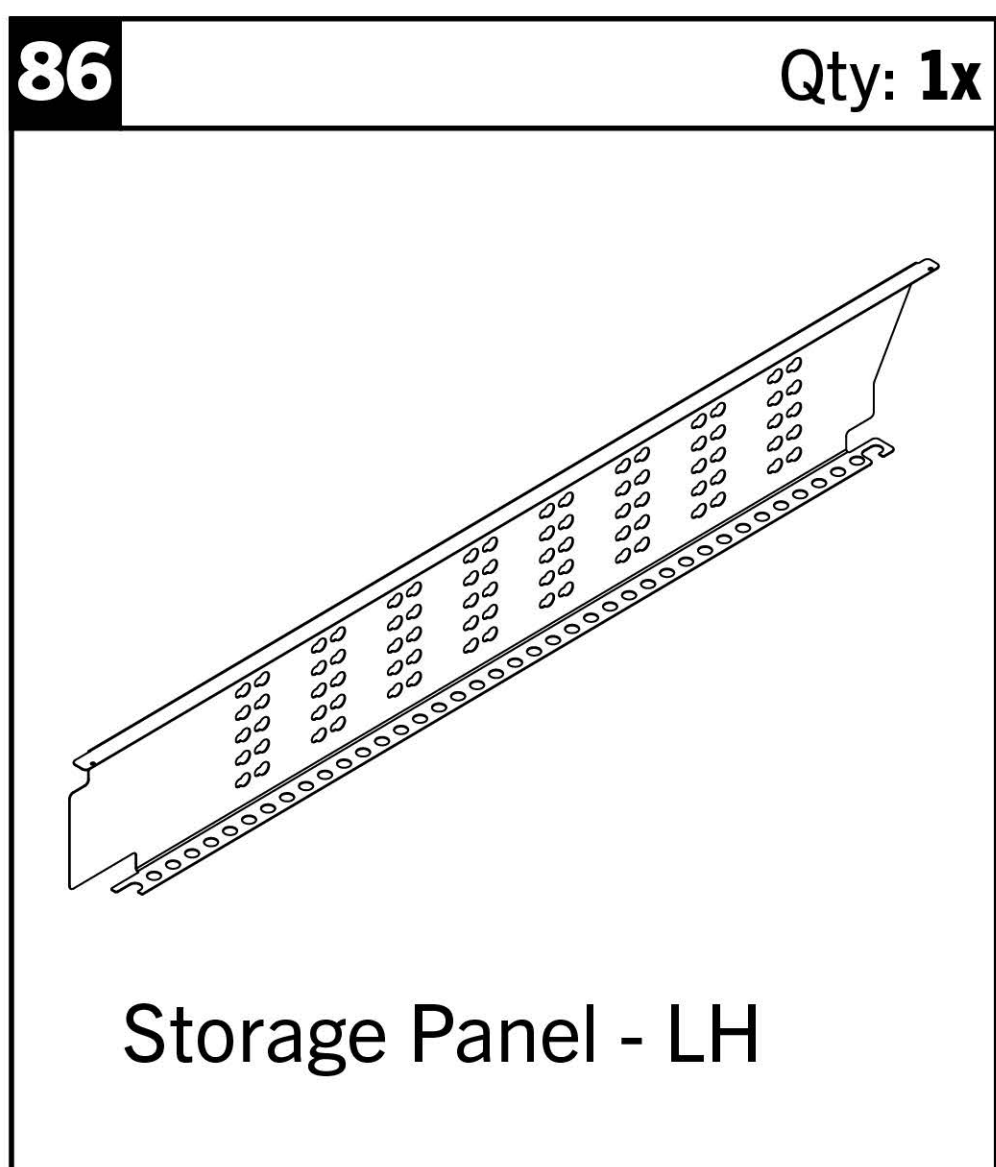
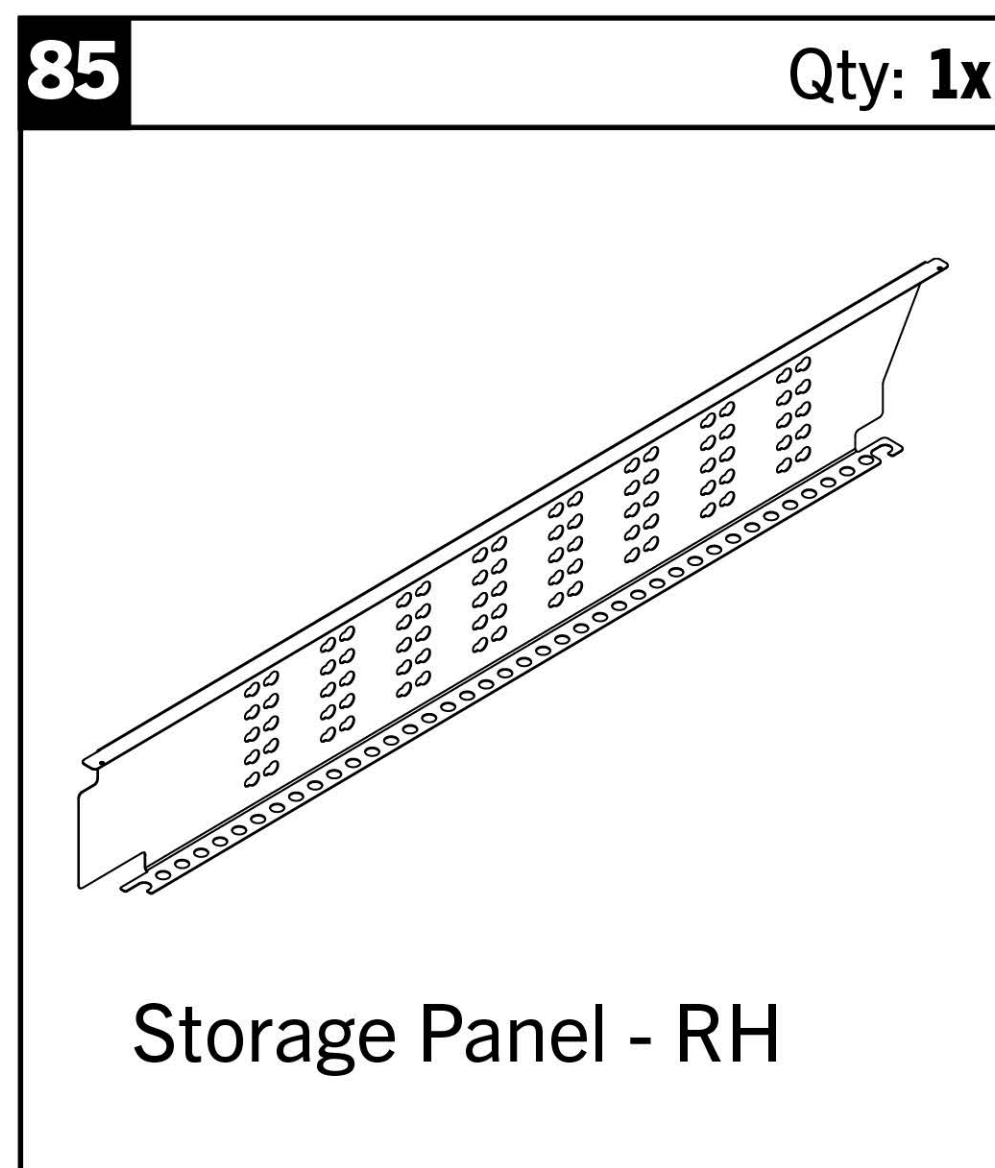
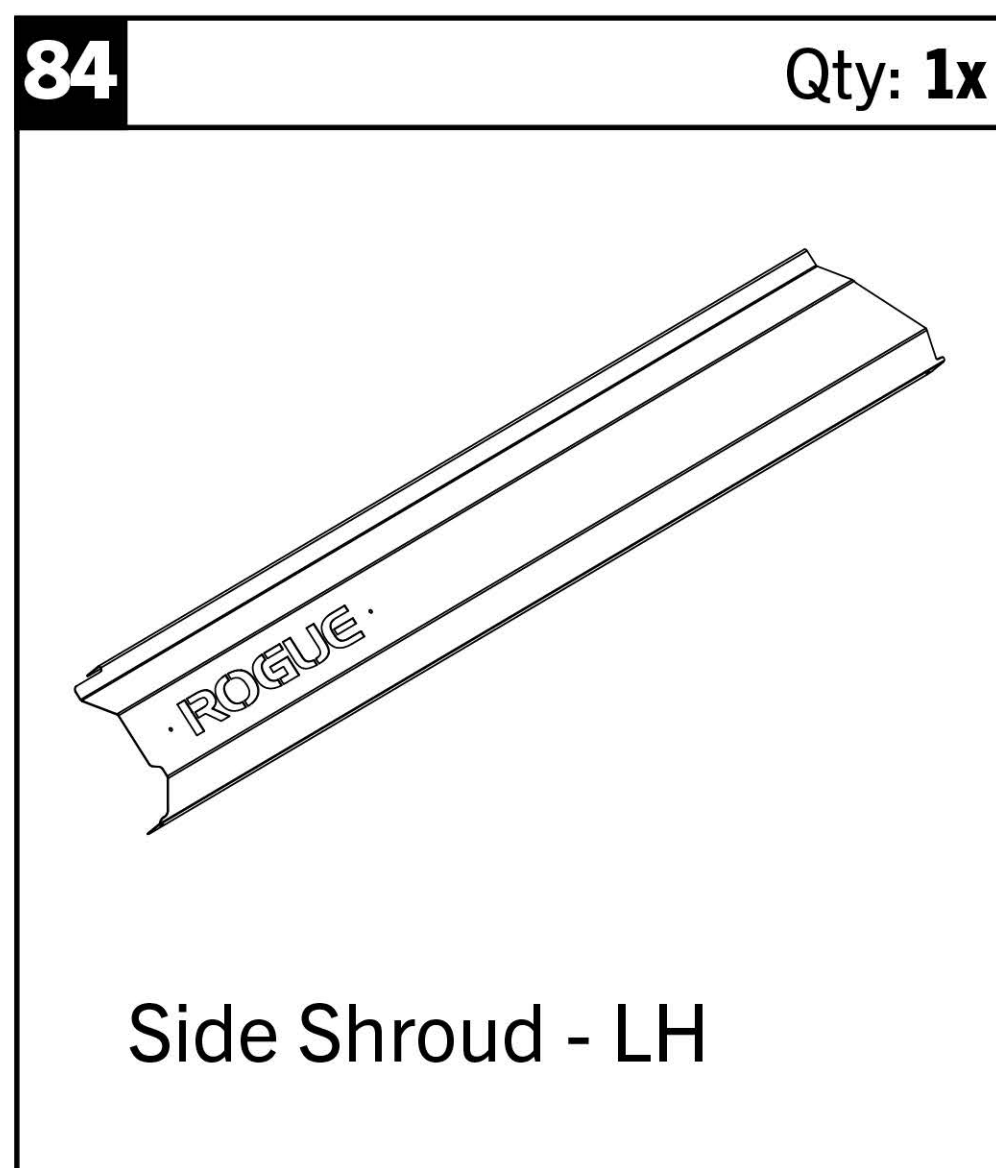
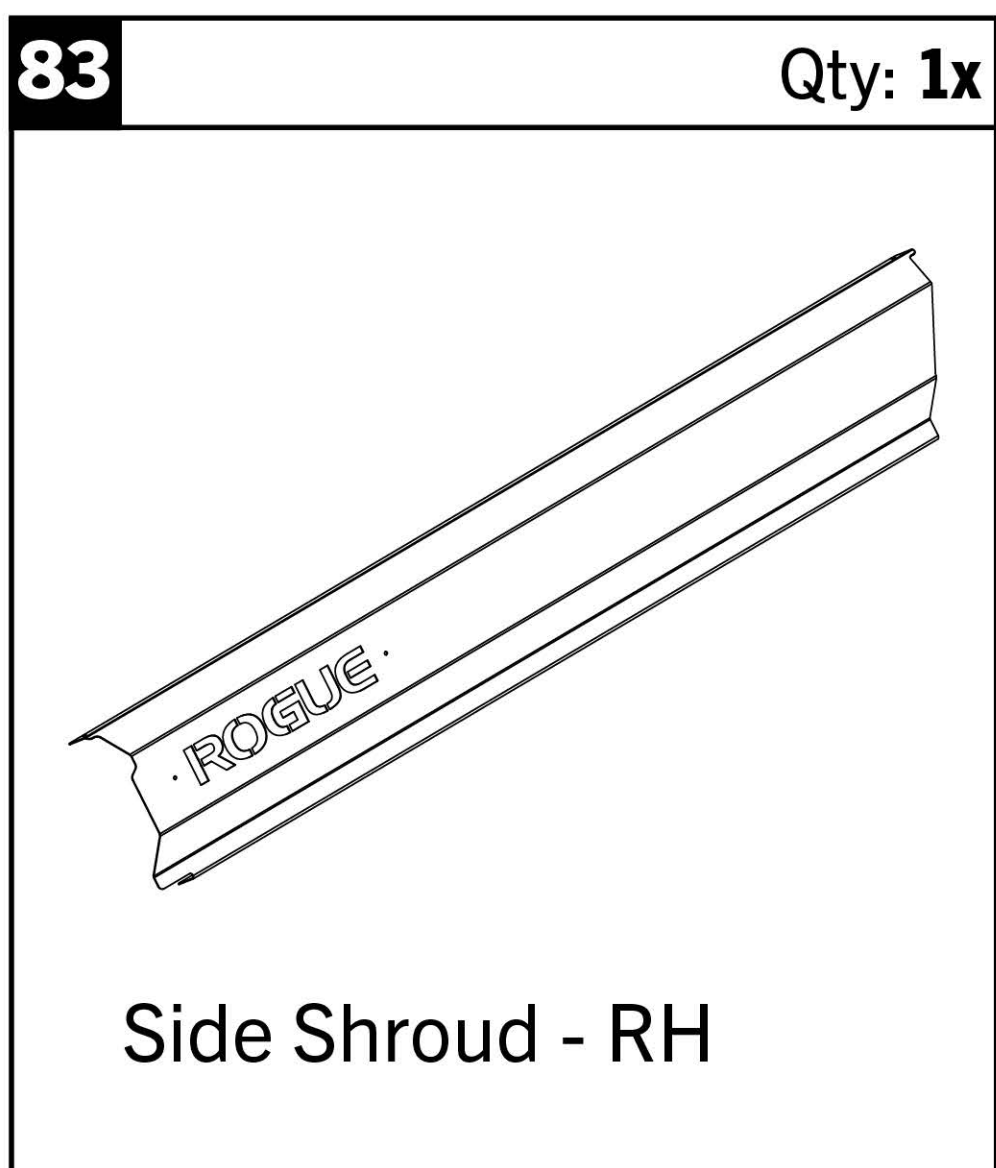
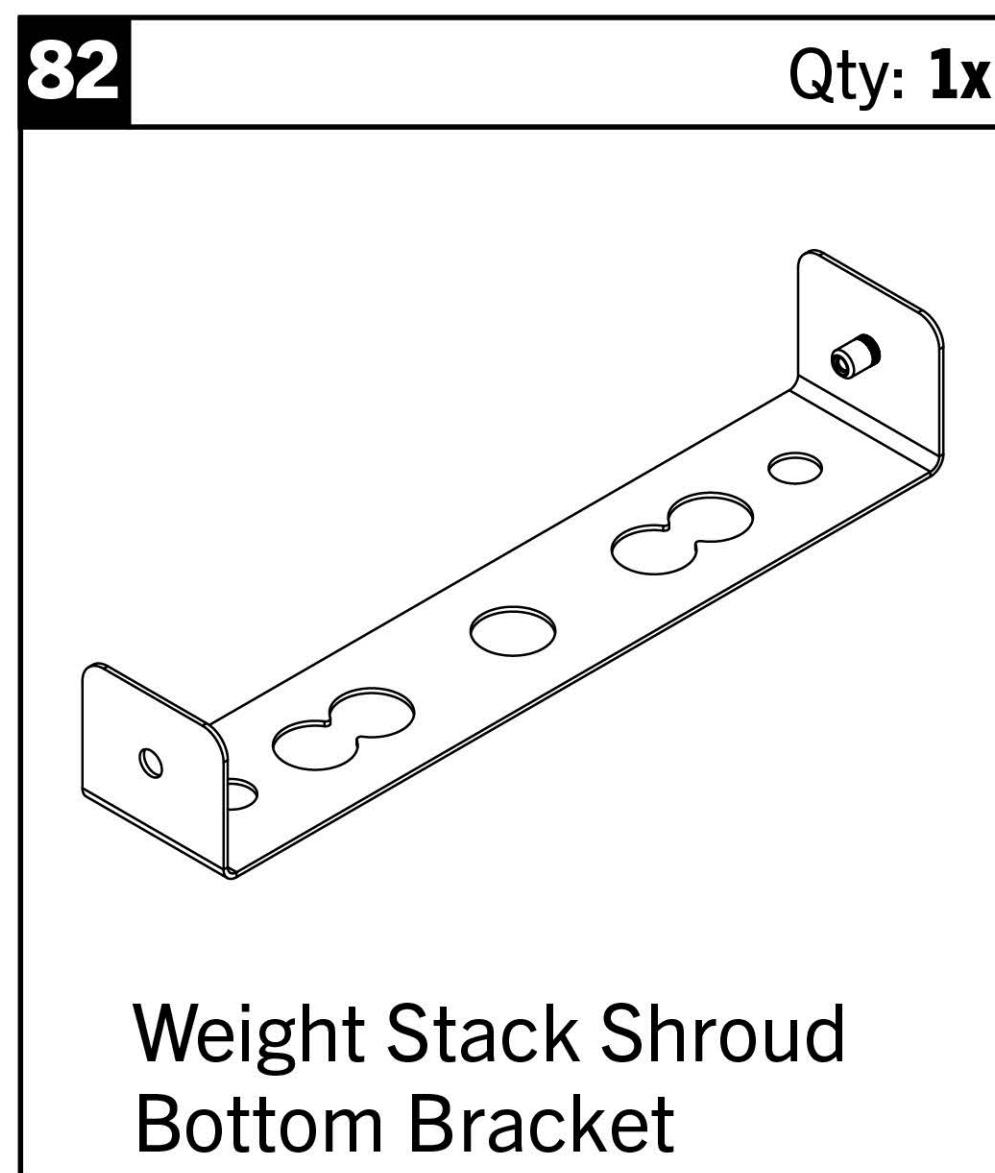
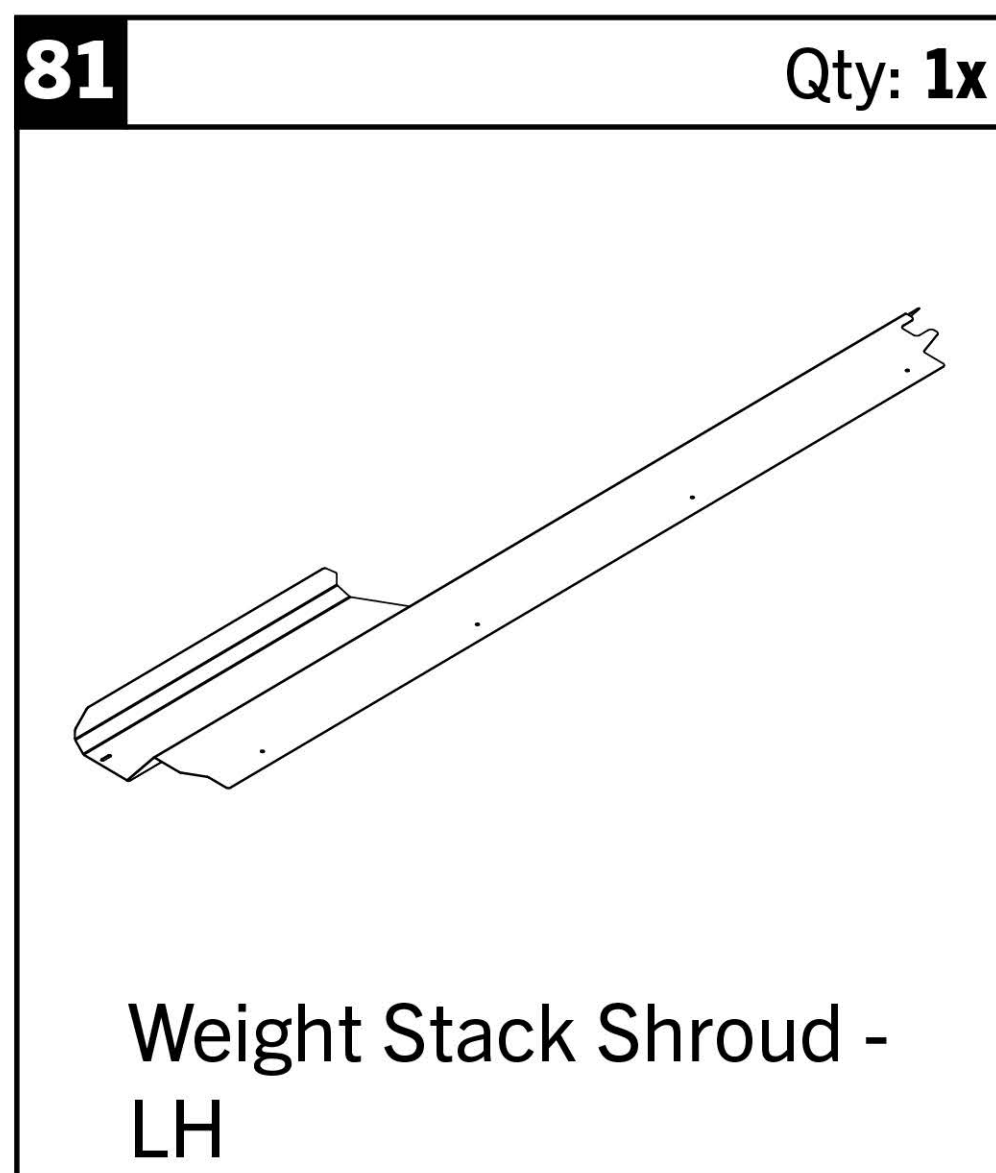
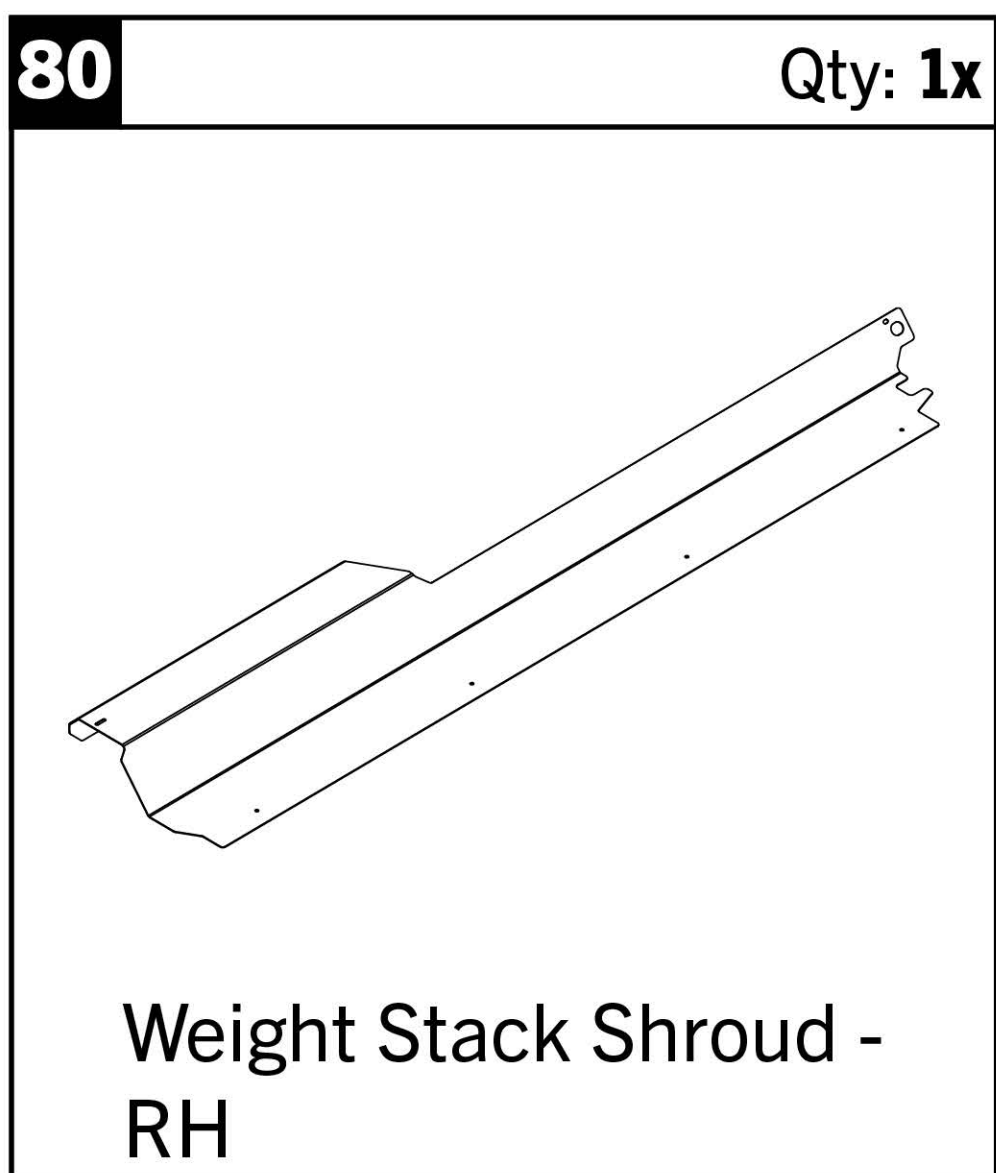

INCLUDED PARTS: SHROUD KIT

Note: Images not shown at scale.

92 Qty: **6x**

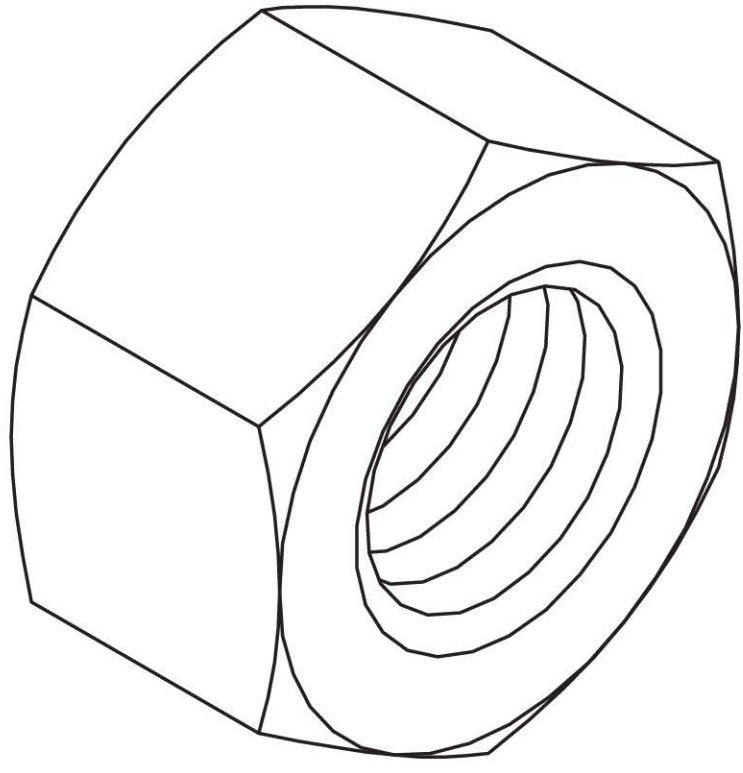

1" Hex Nut

93 Qty: **6x**

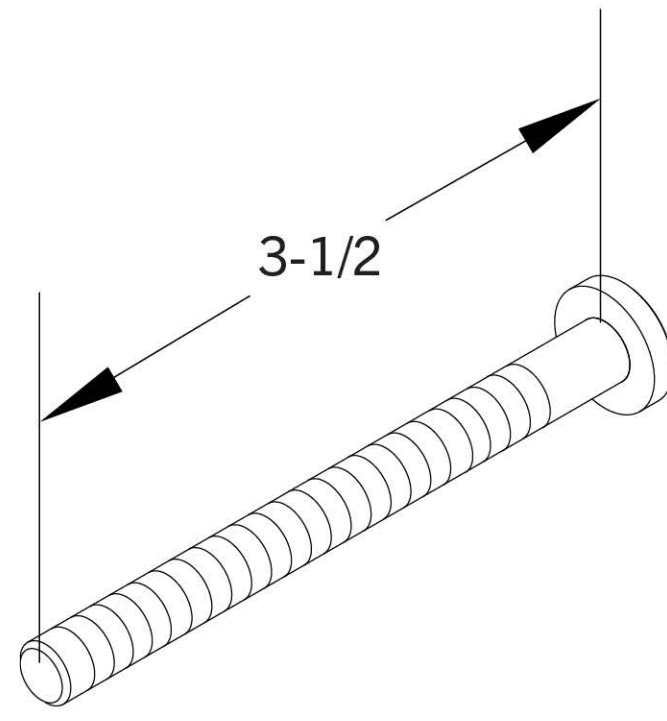

1/4" x 3-1/2" Button Head Screw

94 Qty: **6x**

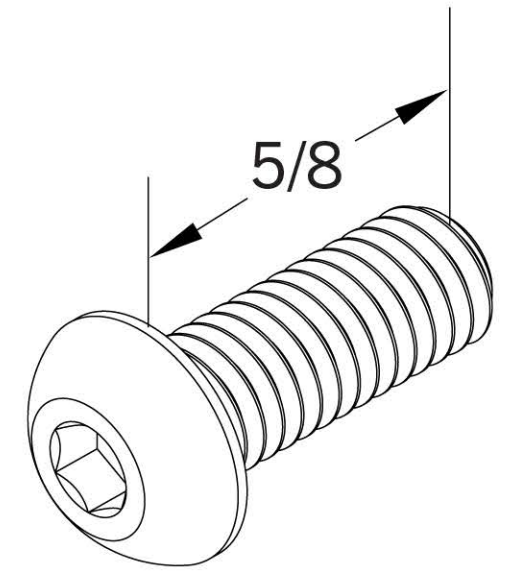

1/4" x 5/8" Button Head Screw

95 Qty: **6x**

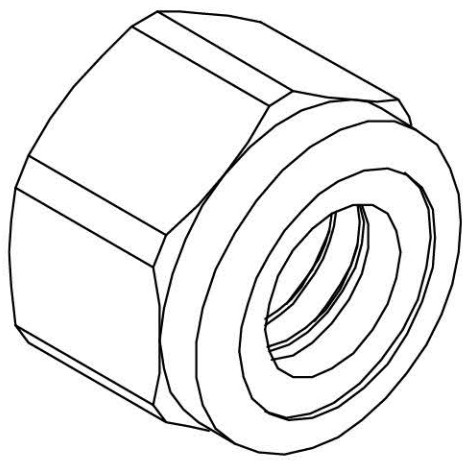

1/4" Nylock Nut

96 Qty: **4x**

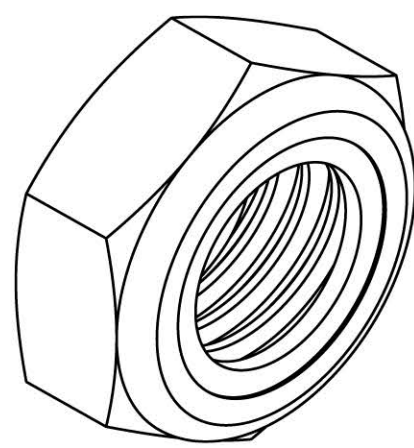

1/4" Thin Nylock Nut

97 Qty: **4x**

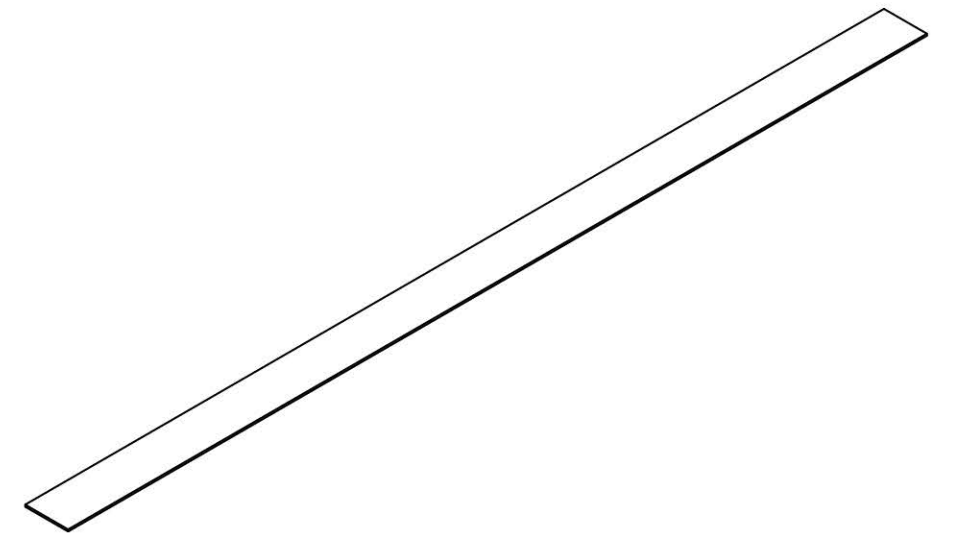

3" Foam Panel

98 Qty: **2x**

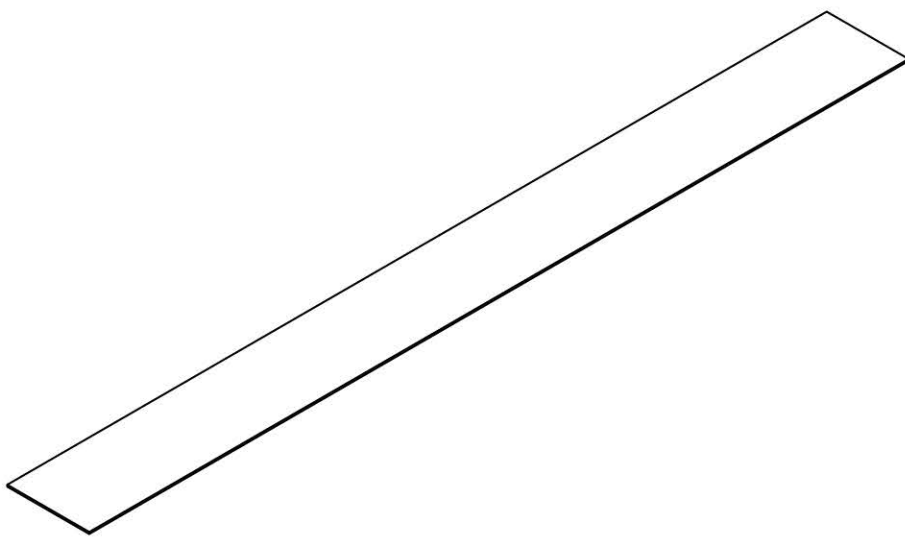

6" Foam Panel

1" HARDWARE LENGTH GUIDE

Note:

- 1" x 5" and 1" x 4-3/4" Bolts shown to scale below to help differentiate variations in length.

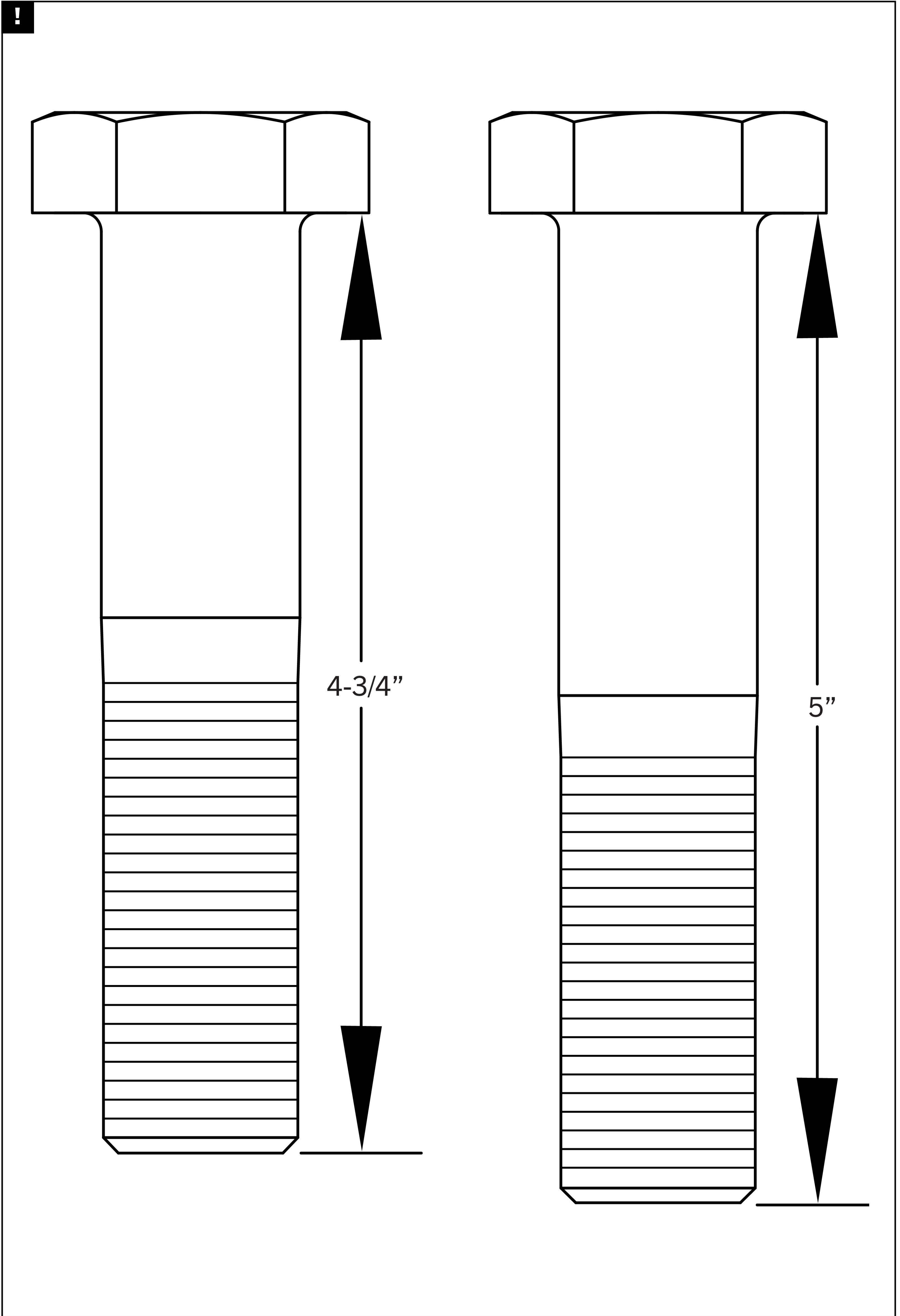

STEP 1

IMPORTANT:

• **DO NOT USE TOOLS TO TIGHTEN THROUGHOUT ASSEMBLY UNLESS OTHERWISE SPECIFIED.**

- If modifying existing rack with Add-on Kit, skip Steps 1-4 and proceed to **STEP 5**.
- While pulling the handle triggers, slide Swivel Trolley RH [19] and Swivel Trolley LH [20] onto two Monster Uprights [1].

- Note the orientation of Swivel Trolleys in relation to the feet at bottom of uprights.
- Slide about halfway down Upright and release triggers to lock pop pins in place when the viewing window is showing number 23.

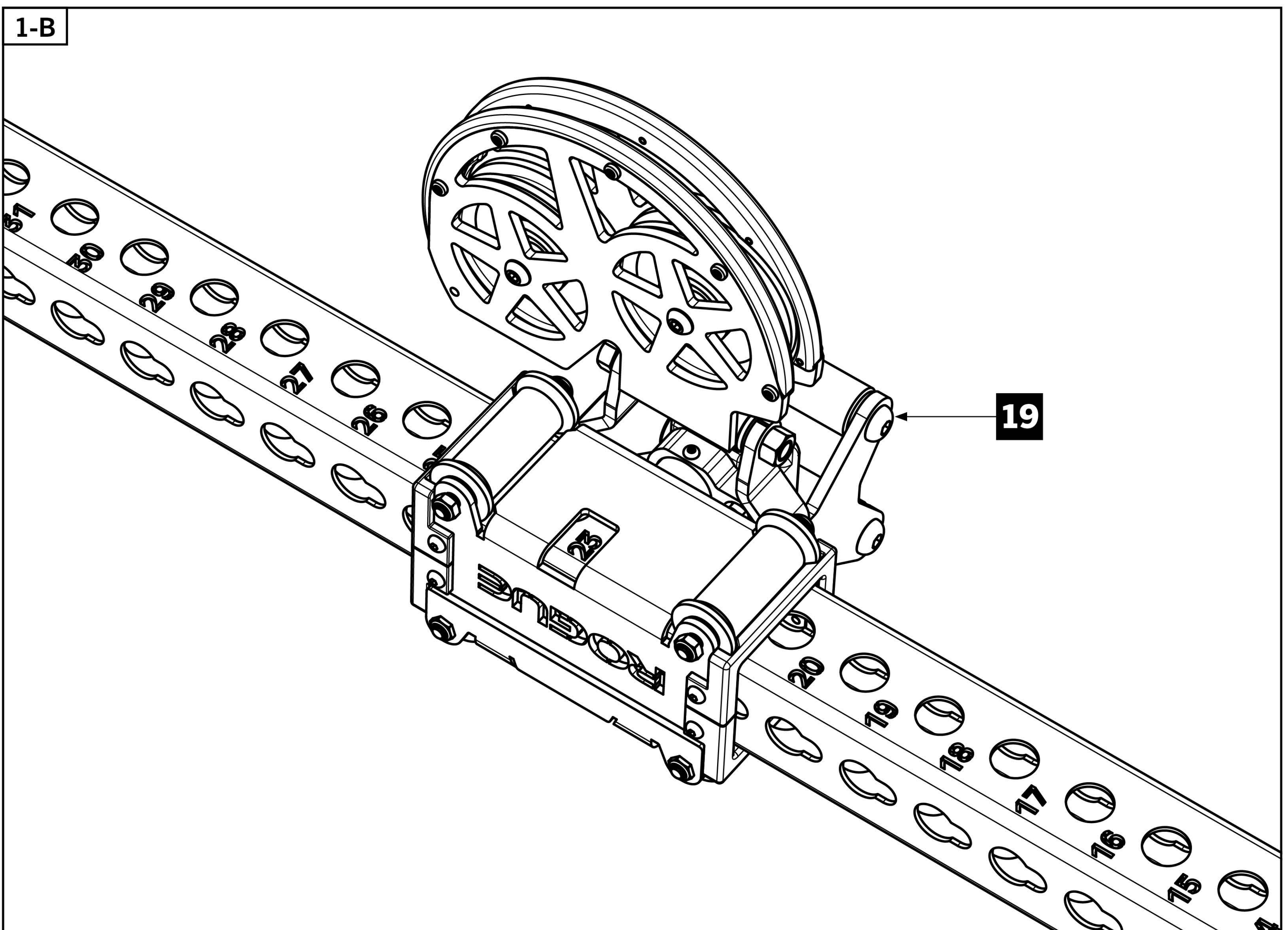
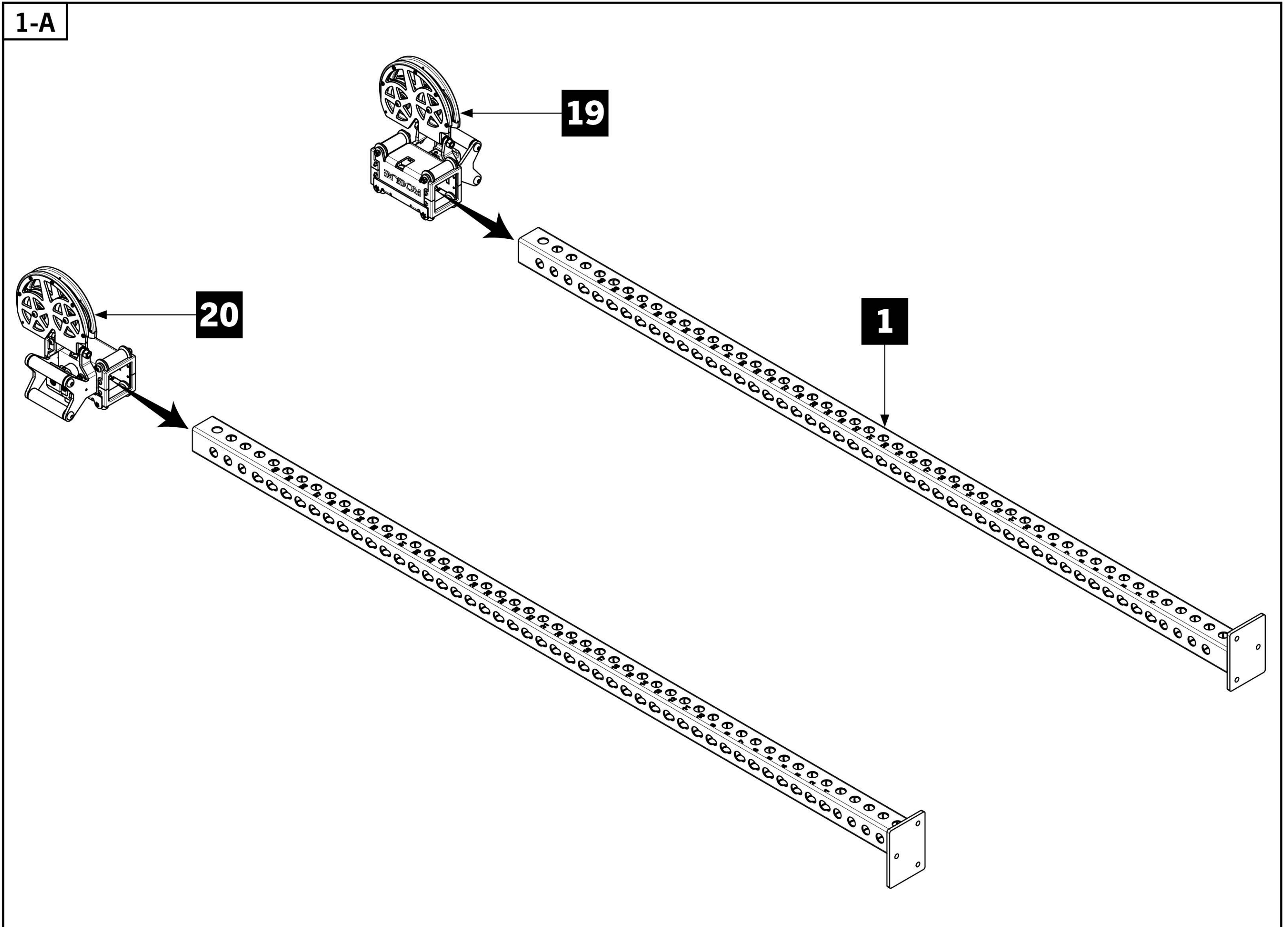

STEP 2

- Refer to overview image to plan assembly and ensure ample floor space is allotted.
- Lay down all parts on a non-abrasive surface in the orientation shown below.
- Position the footplates of uprights approximately 55" apart.
- Note orientation of Swivel Trolleys and Upright feet in relation to the ground.
- Connect Uprights to Crossmembers using 1"x4-3/4" Hex Bolts [13], 1" x 5" Hex Bolts [12], 1" Flat Washers [14], 1" Lock Washers [15], and 1" Hex Nuts [16].
- Ensure to use 1" x 5" Hex Bolts [12] for central uprights.
- **HAND-TIGHTEN ONLY.** Do not use tools throughout assembly unless specified.

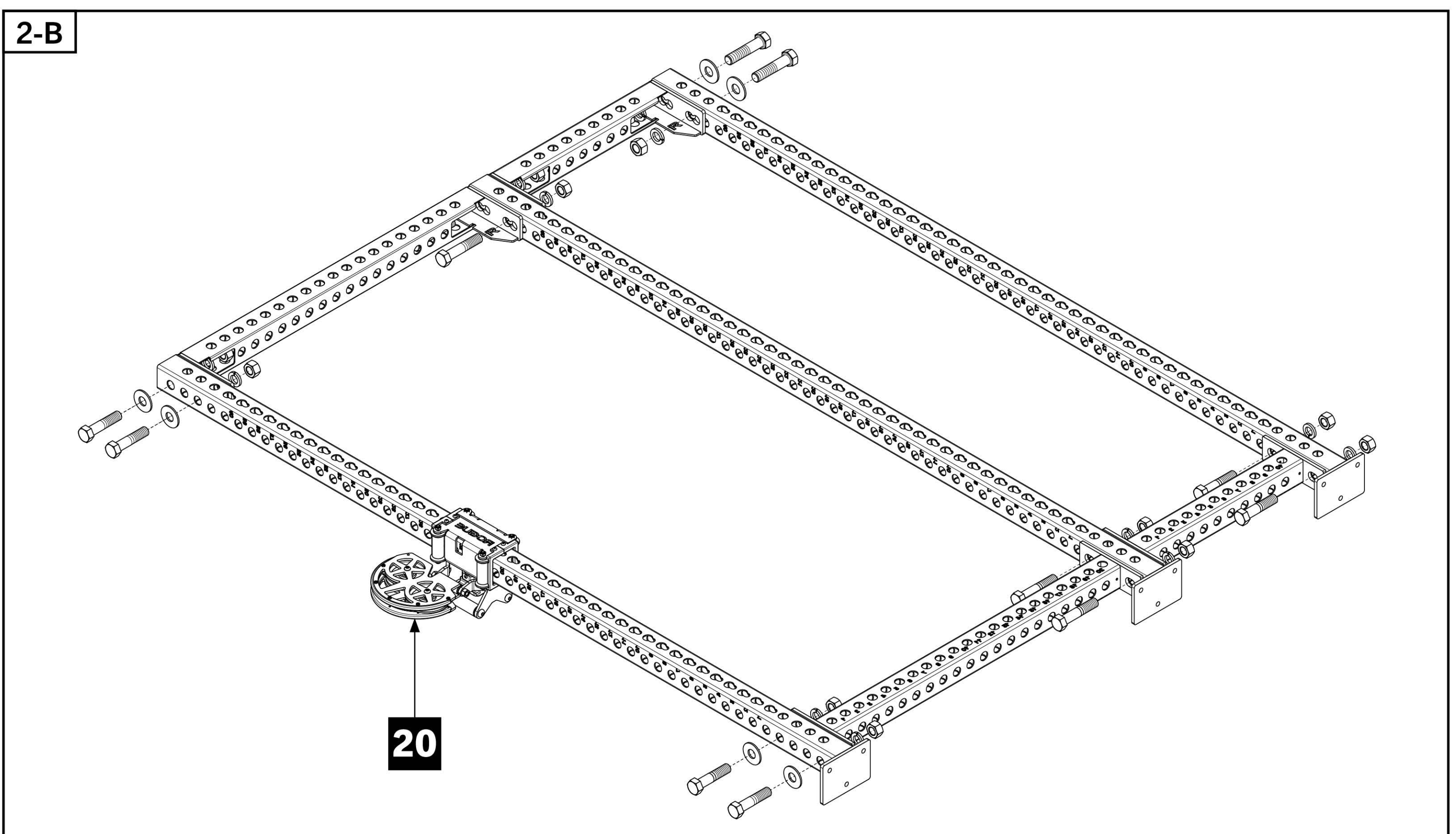
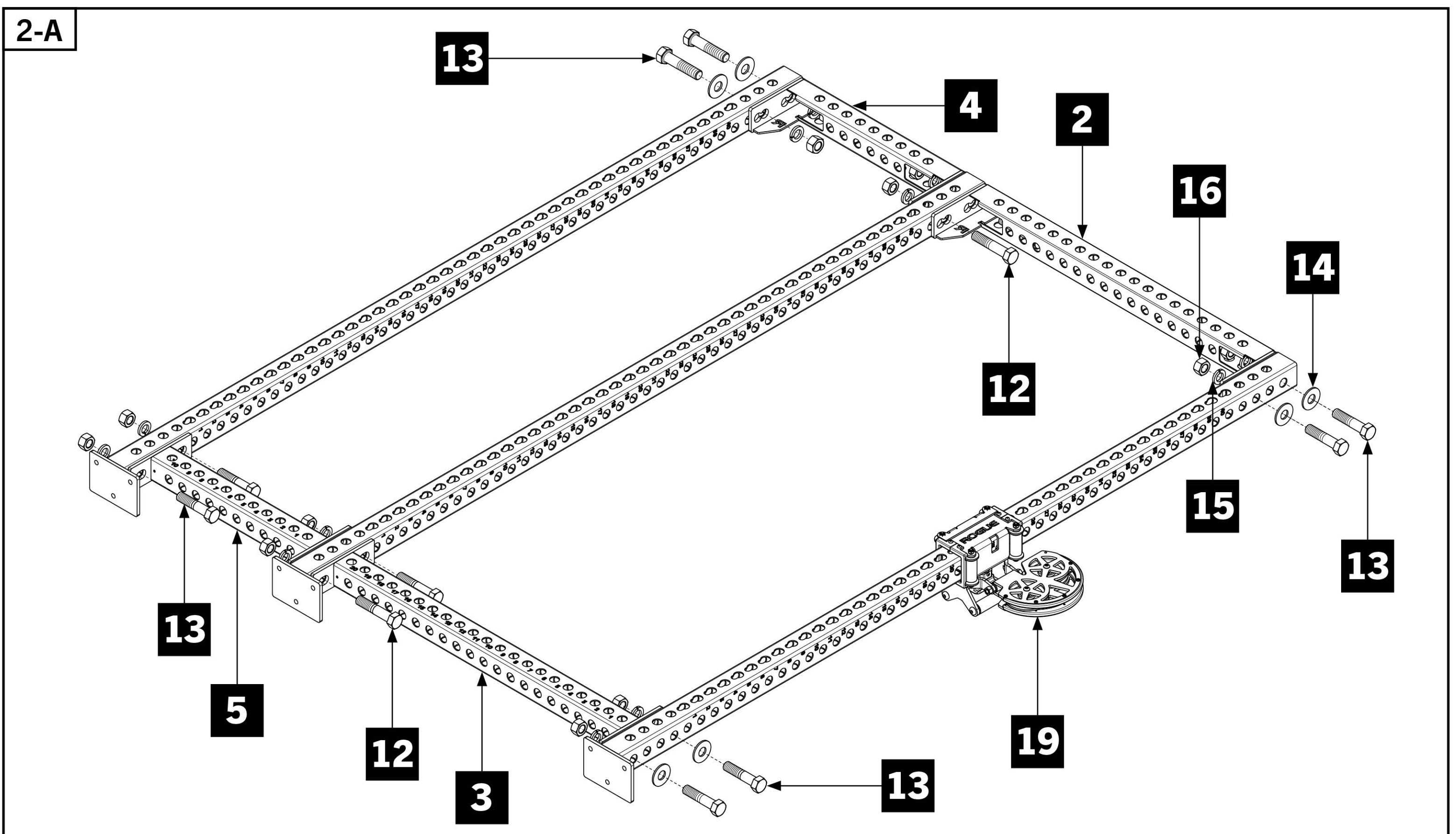
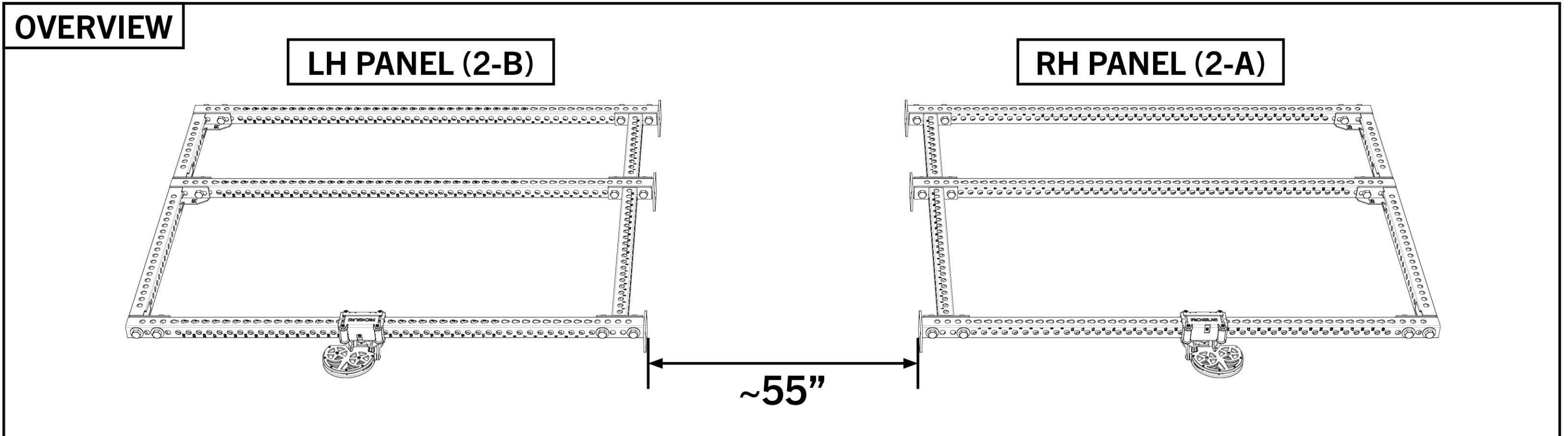

STEP 3

IMPORTANT:

- For safety, we recommend the remainder of these instructions be completed with **2 or 3 people**.
- Have two people stand one assembled panel up first.
- One person stabilizes the first panel while the other stands up the second panel.

- One or two people should stabilize both panels, ensuring panels don't fall while another person assembles the spanning Crossmembers in **STEP 4**.

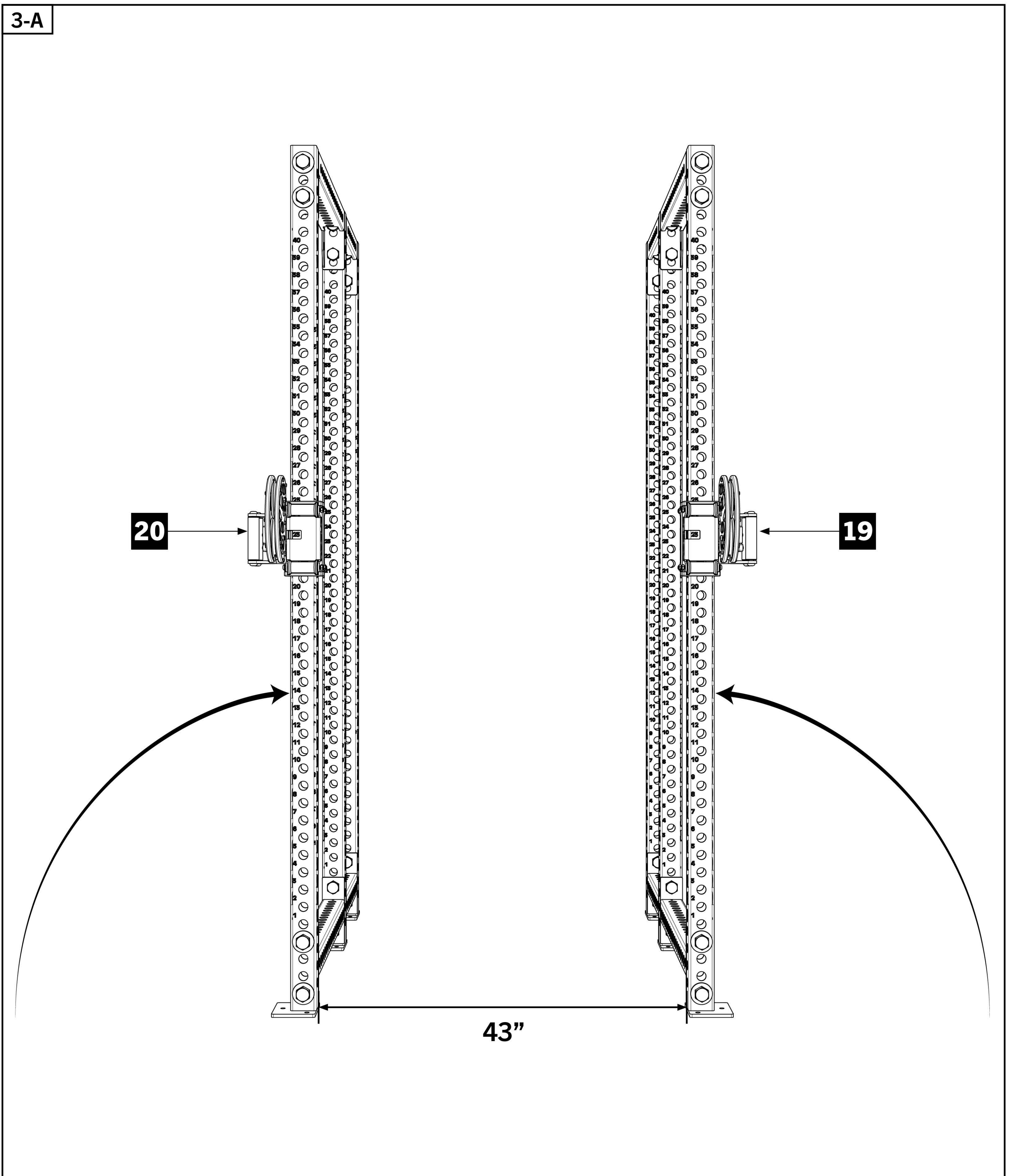
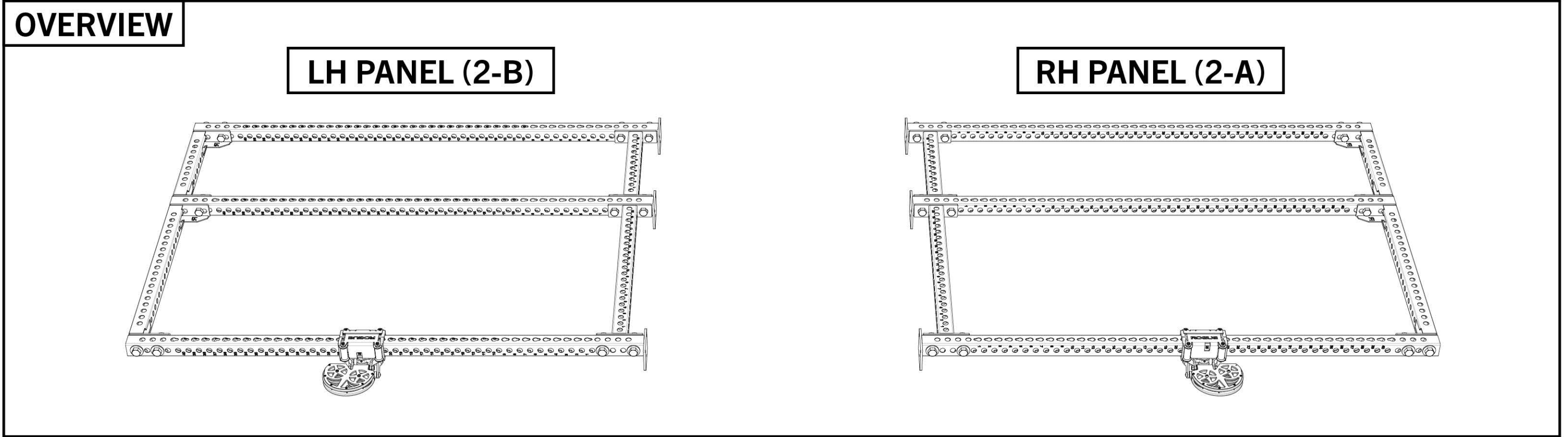

STEP 4

Tools Required:

- 3/8" Allen Key
- Attach Nameplate Crossmember [6] to middle Uprights using 1" x 4-3/4" Hex Bolt [13], 1" Flat Washers [14], 1" Lock Washers [15], and 1" Hex Nuts [16].

- Attach Pull-up Bar [7] to front Uprights using 1" Shoulder Bolts [63,62], 1" x 4-1/2" Hex Bolts, 1" Flat Washers, 1" Lock Washers, and 1" Hex Nuts.
- **!** Fully tighten 1" Shoulder Bolts using 3/8" Allen Key. **DO NOT TIGHTEN HEX BOLTS.**

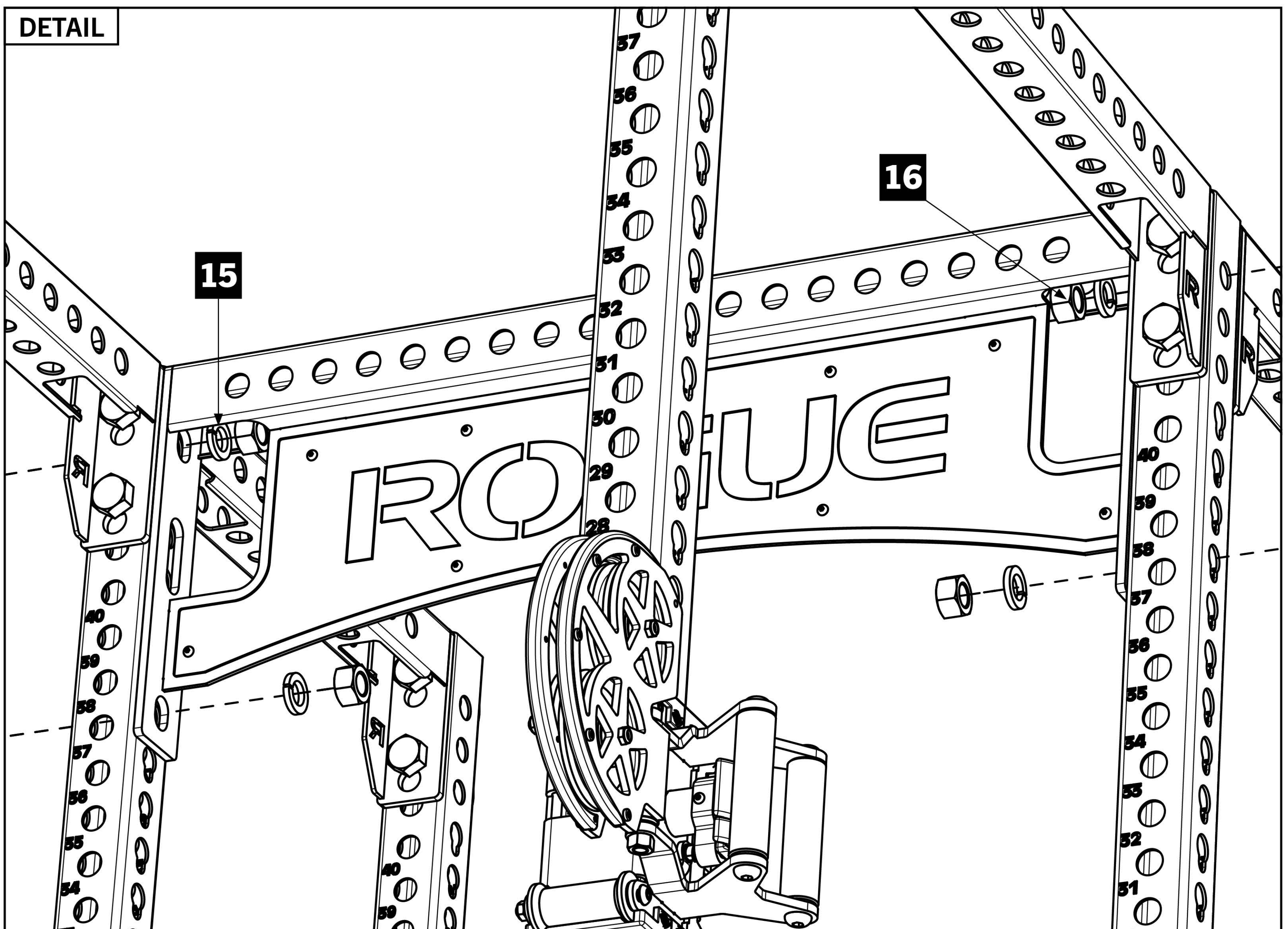
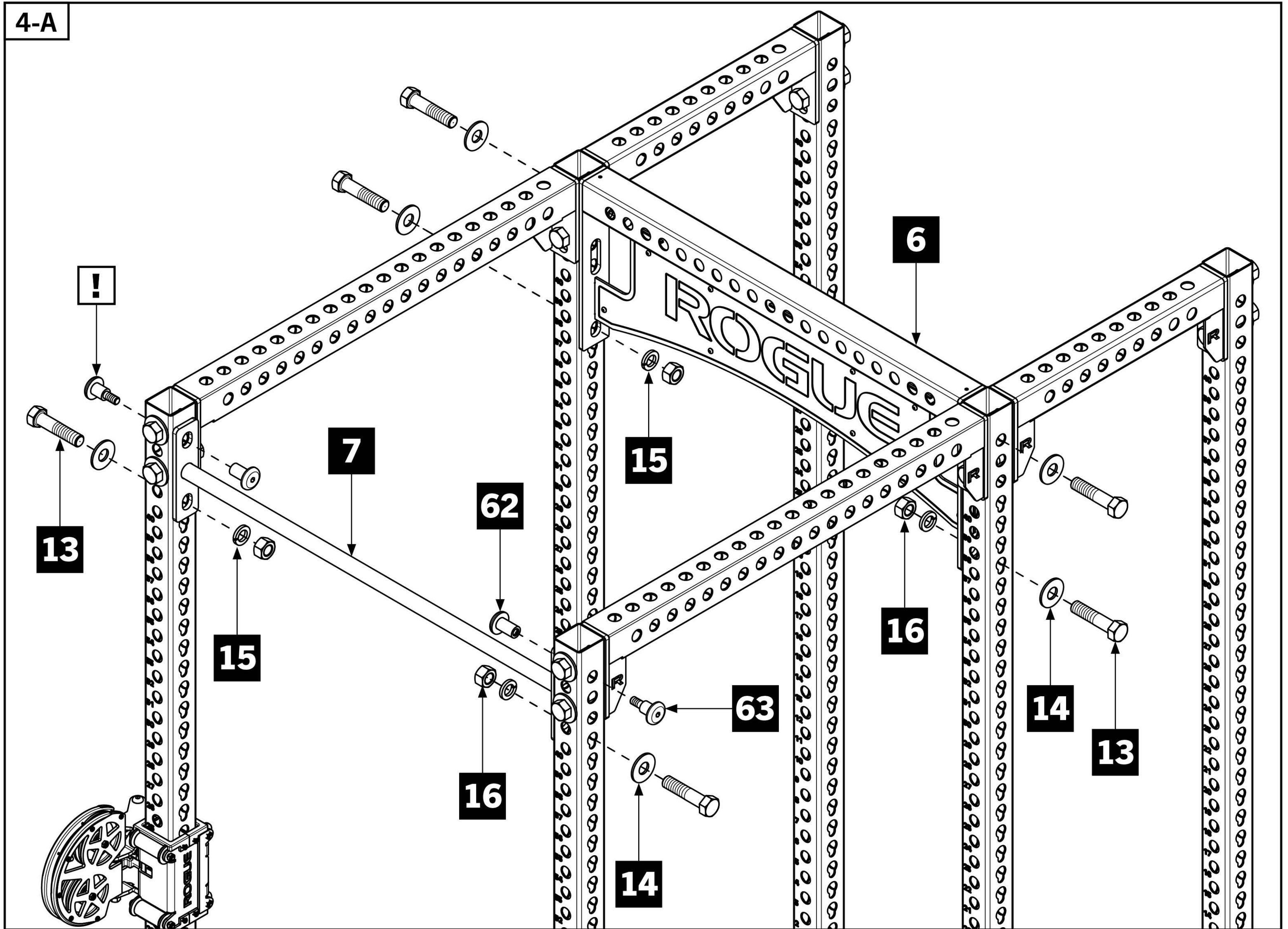

STEP 5 (BEGIN ADD-ON KIT ASSEMBLY)

- If modifying existing RM rack with add-on kit, begin following assembly instructions.
- Leaving 1" x 4-3/4" Hex Bolts in place, remove all four lower Lock Washers and Hex Nuts from rear Uprights as shown in 5-A.
- Attach Low Row Crossmember [18] and re-assemble the hardware removed above.

Note:

-  "X" cutout on Low Row Crossmember should be facing down towards the ground.

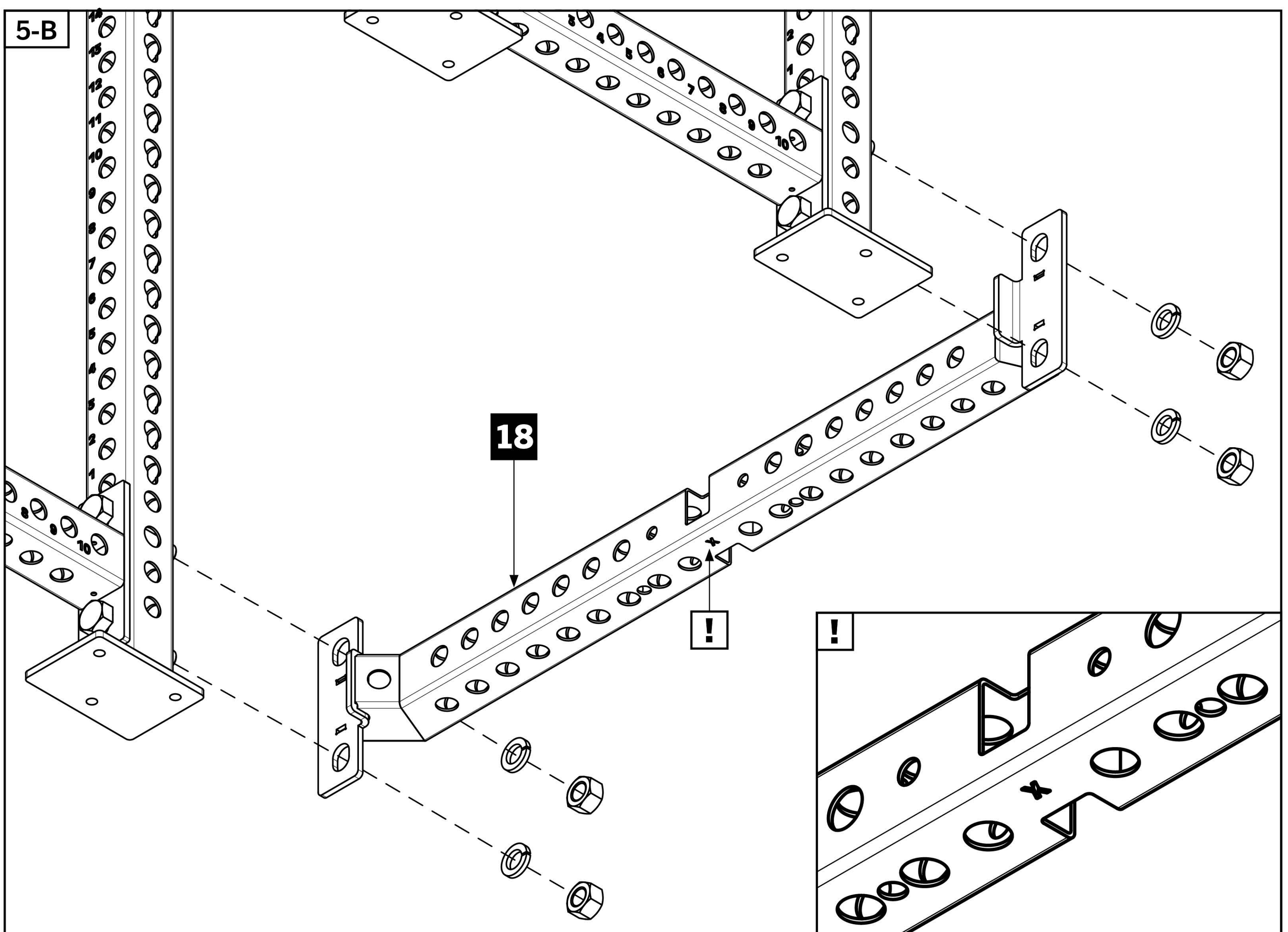
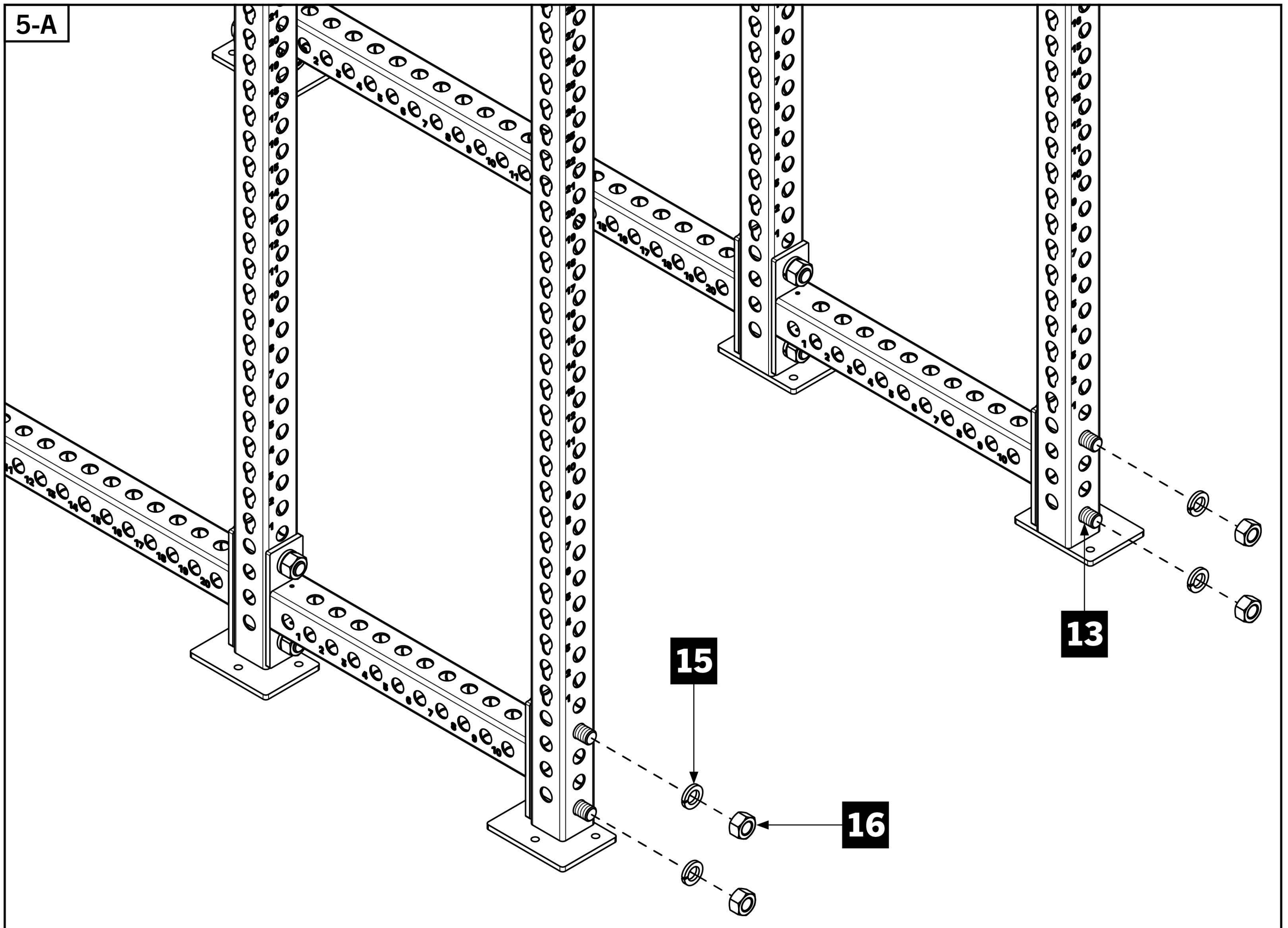

STEP 6 (ADD-ON KIT ONLY)

IMPORTANT:

- **LOOSEN BUT DO NOT REMOVE ALL 1" HARDWARE ON ENTIRE RACK.**

- Loosen but do not remove all 1" hardware on entire rack.
- Remove Pull-up Bar and hardware from front of rack and set parts aside.
- Remove additional 1" crossmember hardware shown in **6-B** so that the tops of the front uprights are completely free to move.

Note:

- The tops of the front uprights will need ample slack to complete **STEP 7**. Continue to loosen hardware on bottom of Front Uprights as needed.

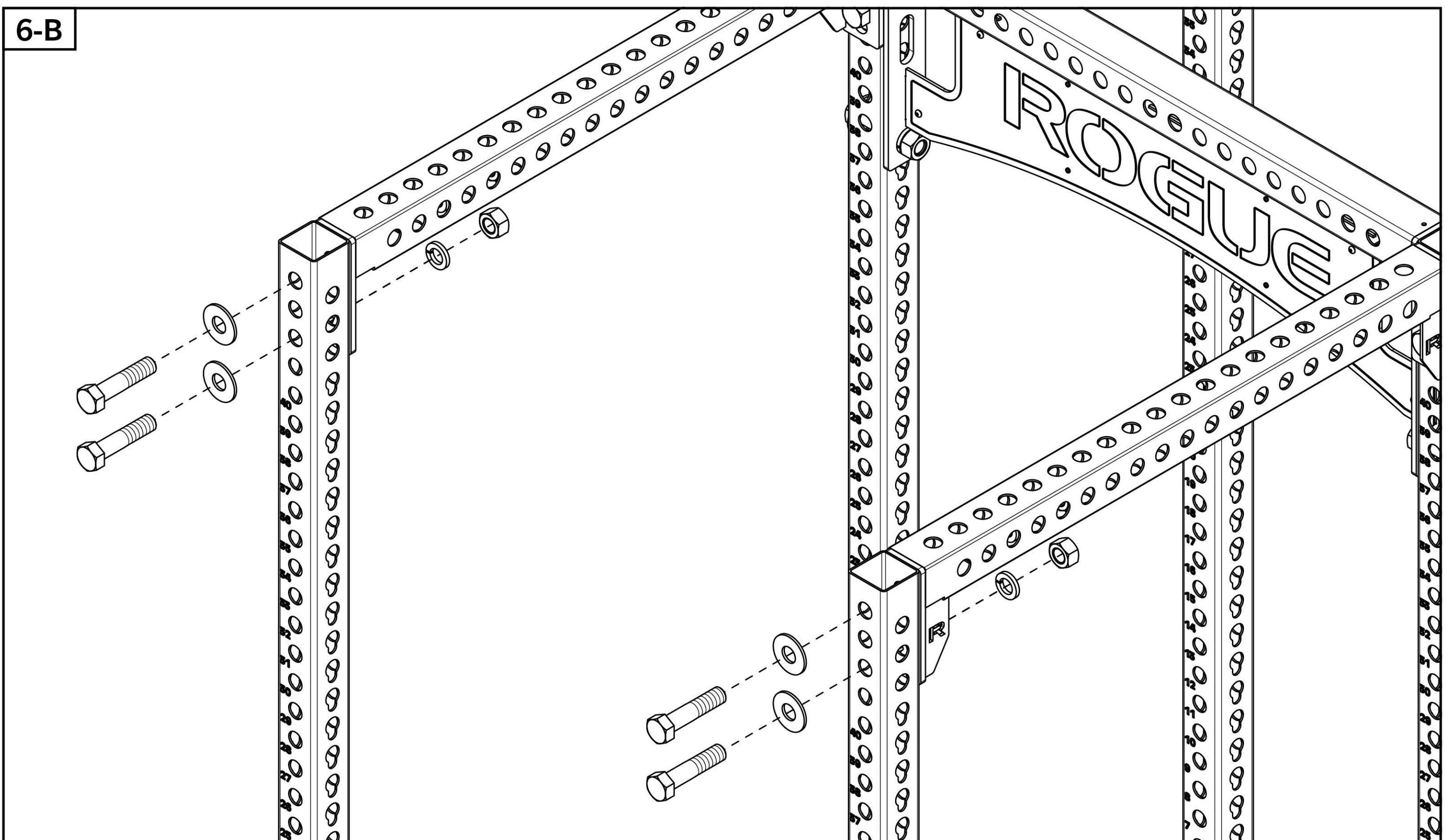
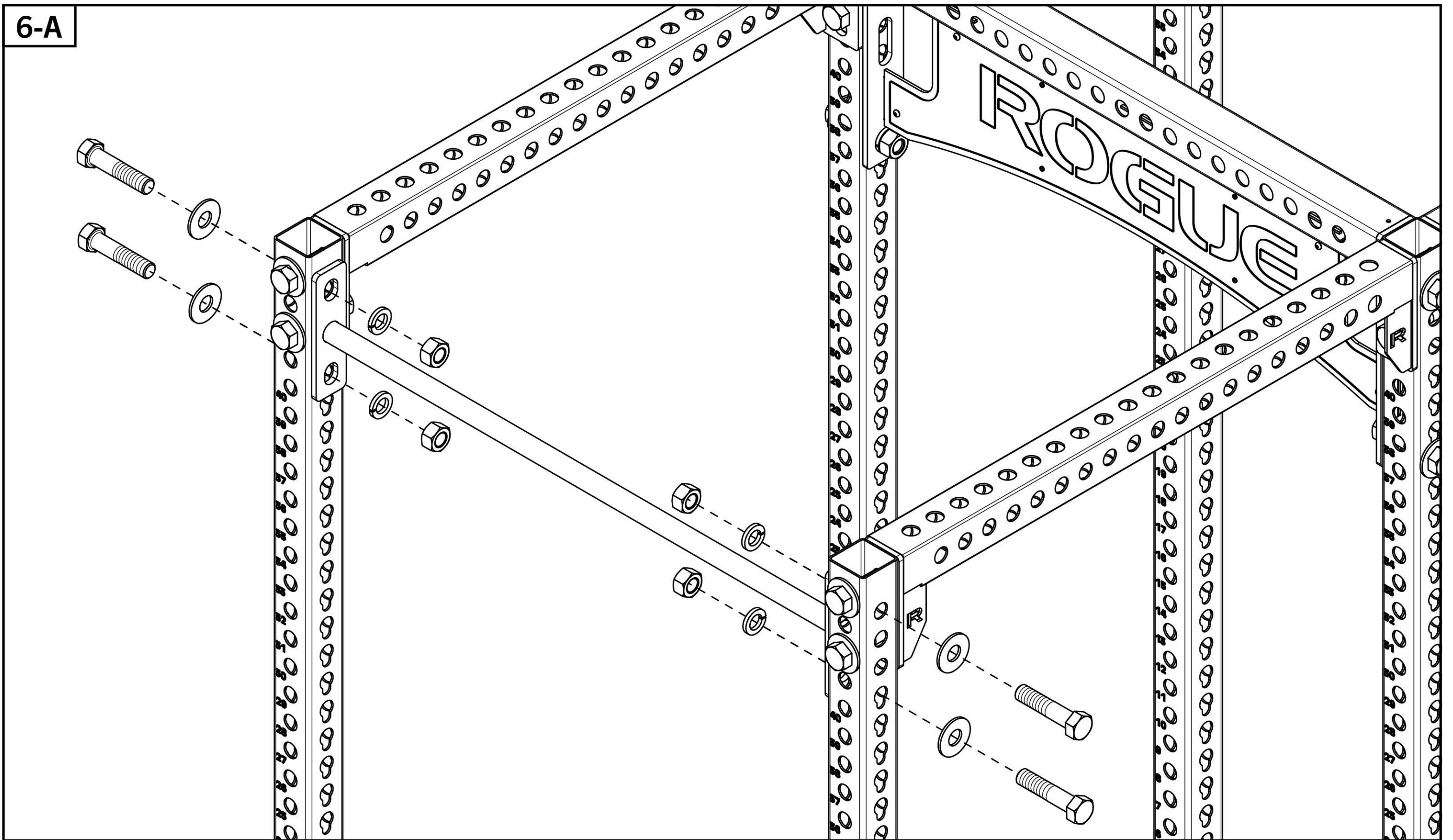
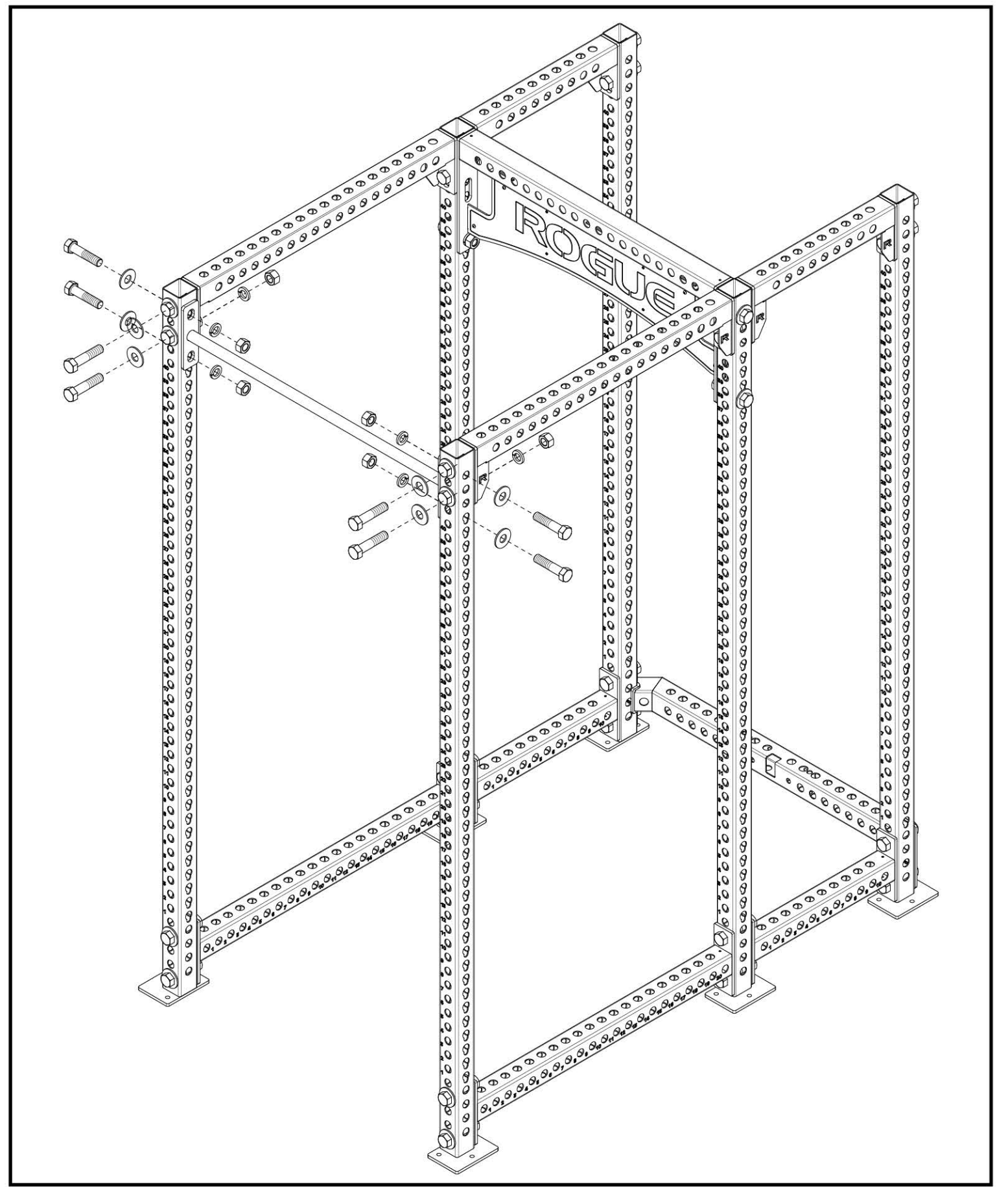

STEP 7 (ADD-ON KIT ONLY)

- While tilting Upright forward, pull the handle triggers and slide LH Swivel Trolley [20] down the front left Upright.
- Repeat this process to assemble RH Swivel Trolley [19] on front right Upright.
- Slide down the Uprights and release triggers when the viewing window is showing the number 23 (refer to **STEP 1-B**).

- Assemble hardware removed in **STEP 6**, replacing the indicated top outer bolts with 1" Shoulder Bolts. **!** Fully tighten **ONLY** the 1" Shoulder Bolts using two 3/8" Allen Keys.

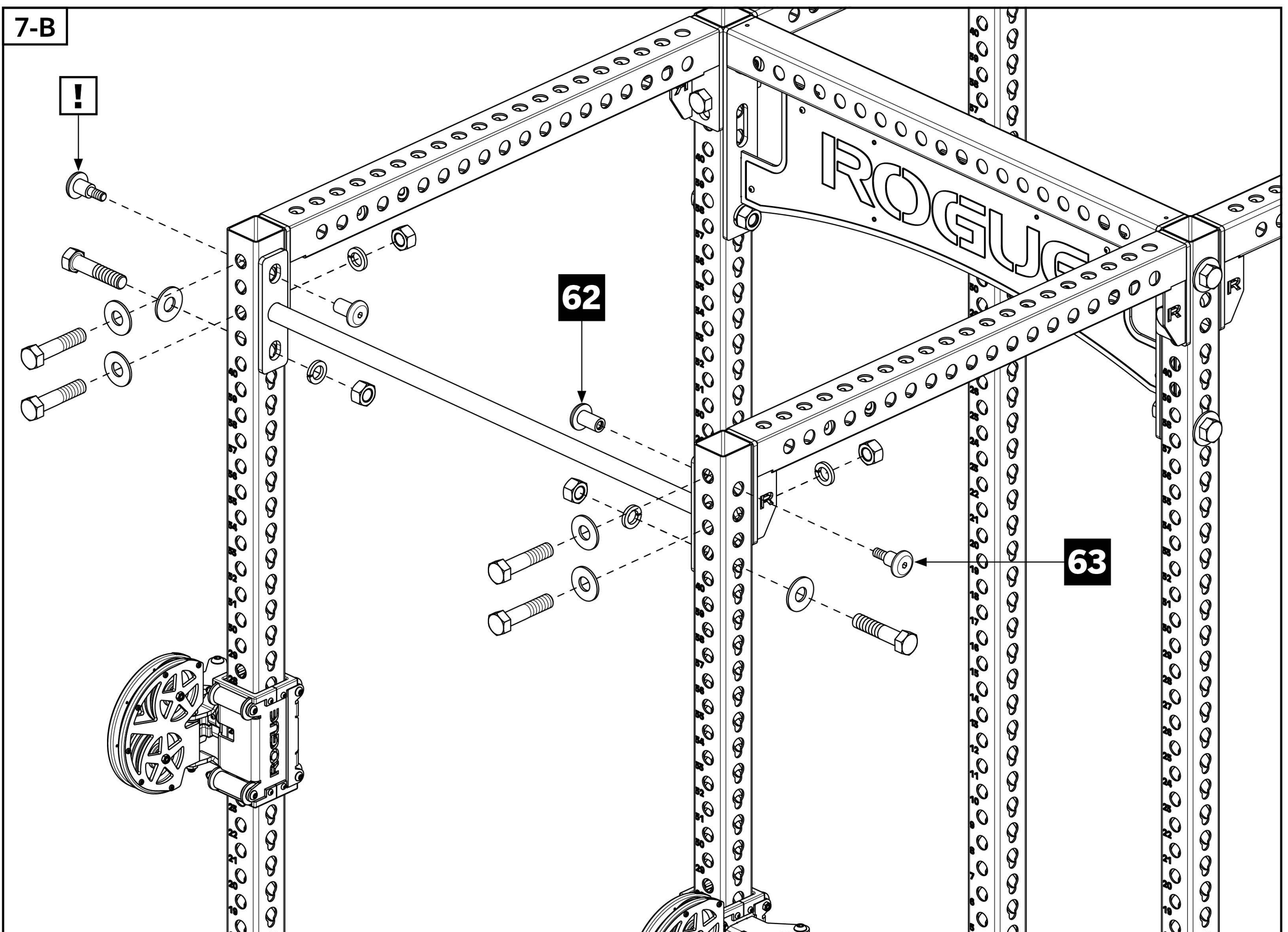
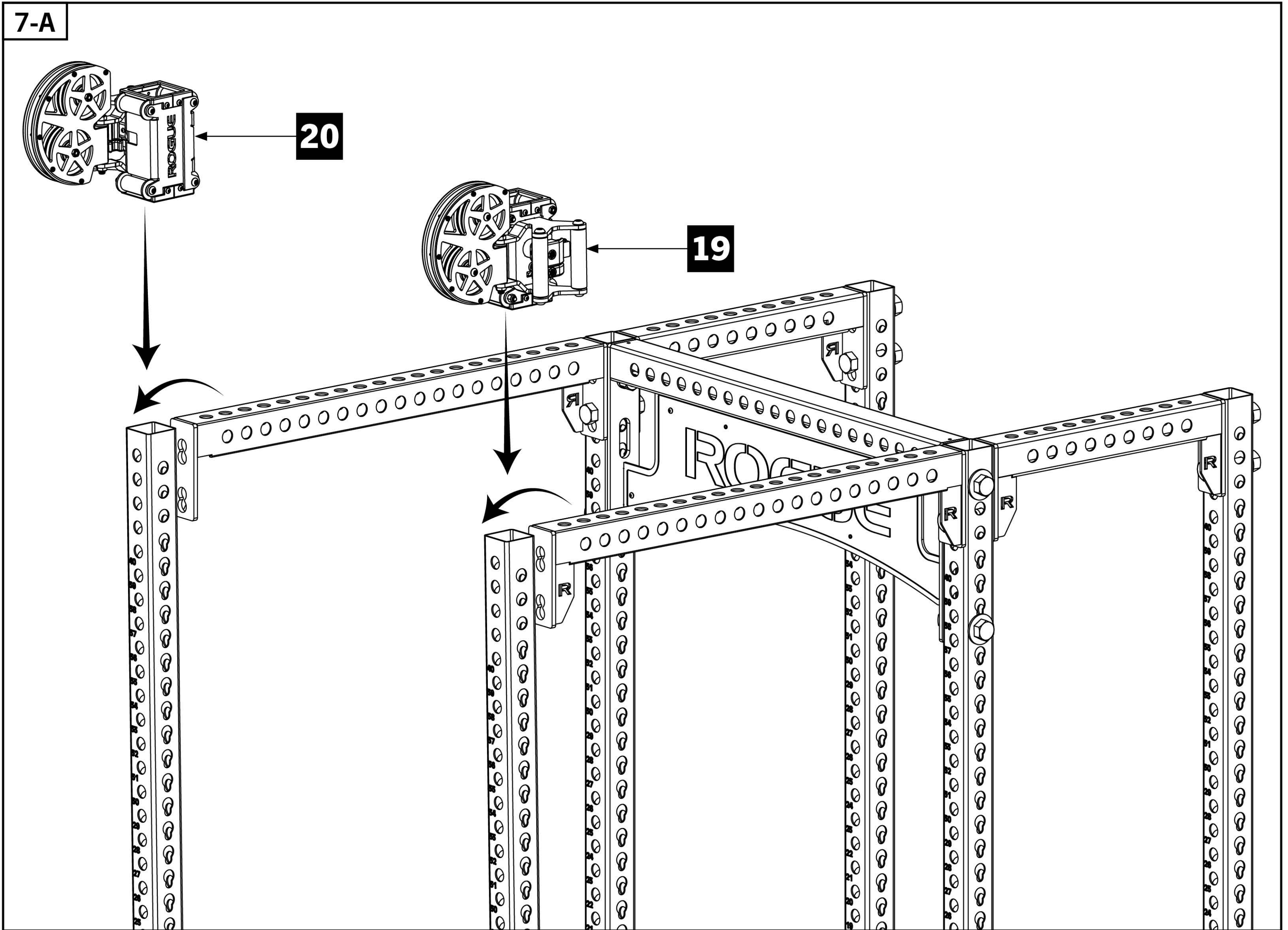

STEP 8

Tools Required:

- 7/32" Allen Key, 9/16" Wrench
- Swivel Trolleys [19,20] need to be calibrated for your specific rack.
- Keeping the Swivel Trolleys locked in place, tighten the Button Head Screws shown in **8-A** using 7/32" Allen Key until looseness or "wobble" is gone.

- Unlock pop pins and roll Trolleys up and down Upright several inches to feel tightness. If wobble persists, tighten the Screws in **8-A** again. If any friction is felt, Trolleys are too tight and Screws should be loosened a quarter turn.

- Once calibrated, tighten both rollers on rear of Trolleys using Allen Key and Wrench.

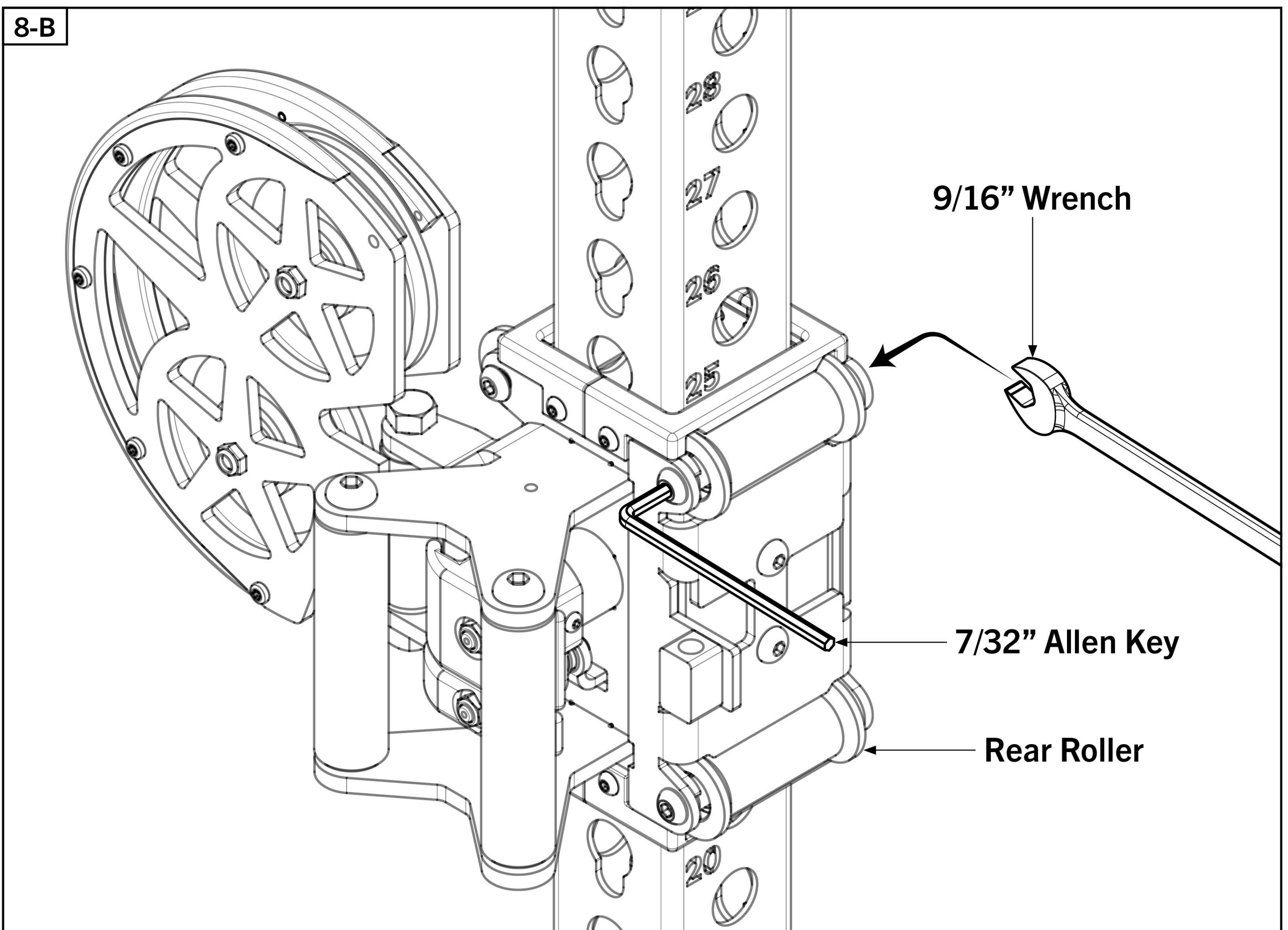
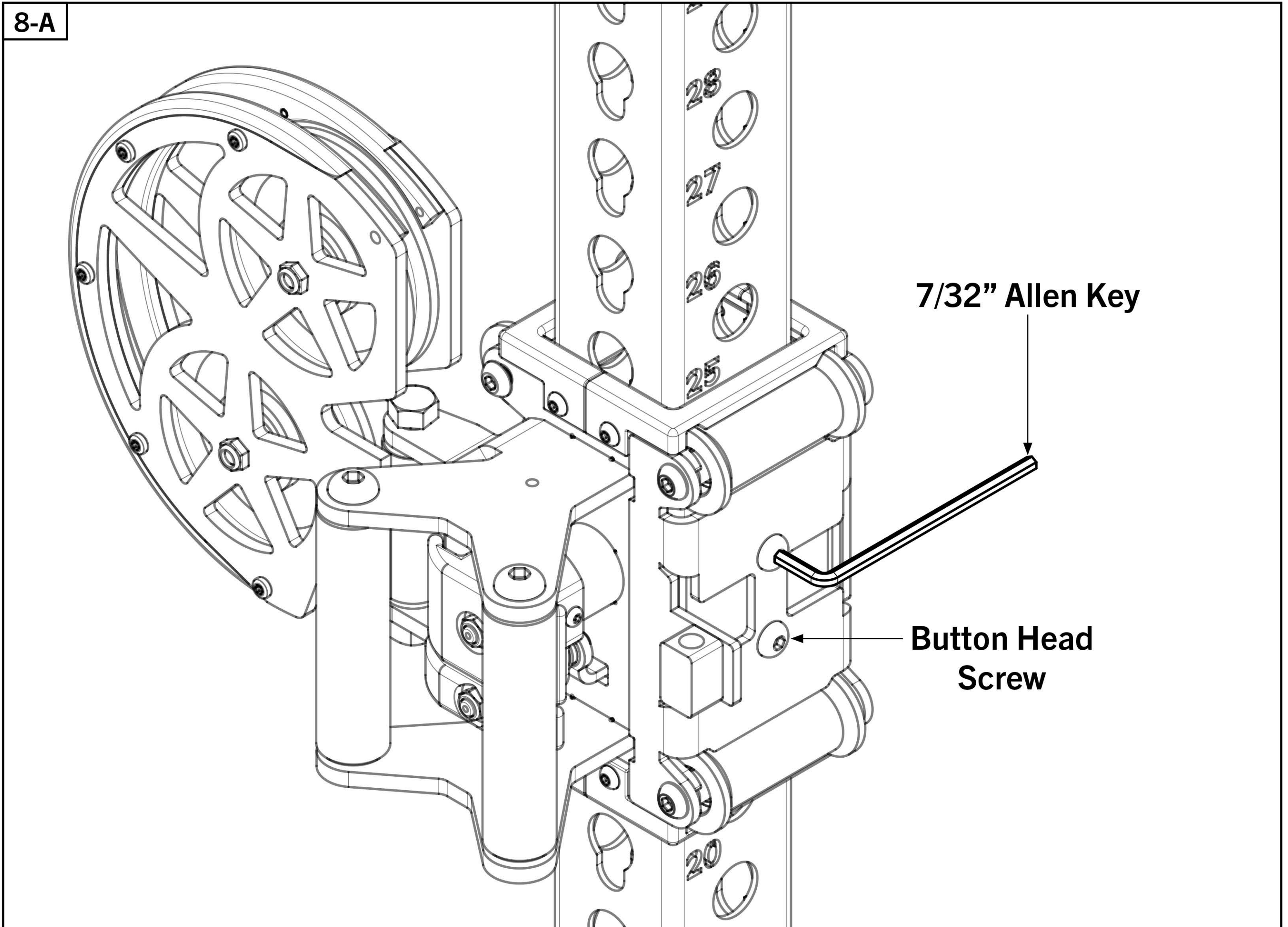

STEP 9

- For ease of assembly, pull the pop-pin and remove Foot Catch from Low Row Foot Plate Assembly as shown in detail view (right).
- Attach Foot Plate Assembly [28] and Low Rear Pulley Assembly [29] to Low Row Crossmember [18] using indicated 5/8" and 1/2" hardware below.

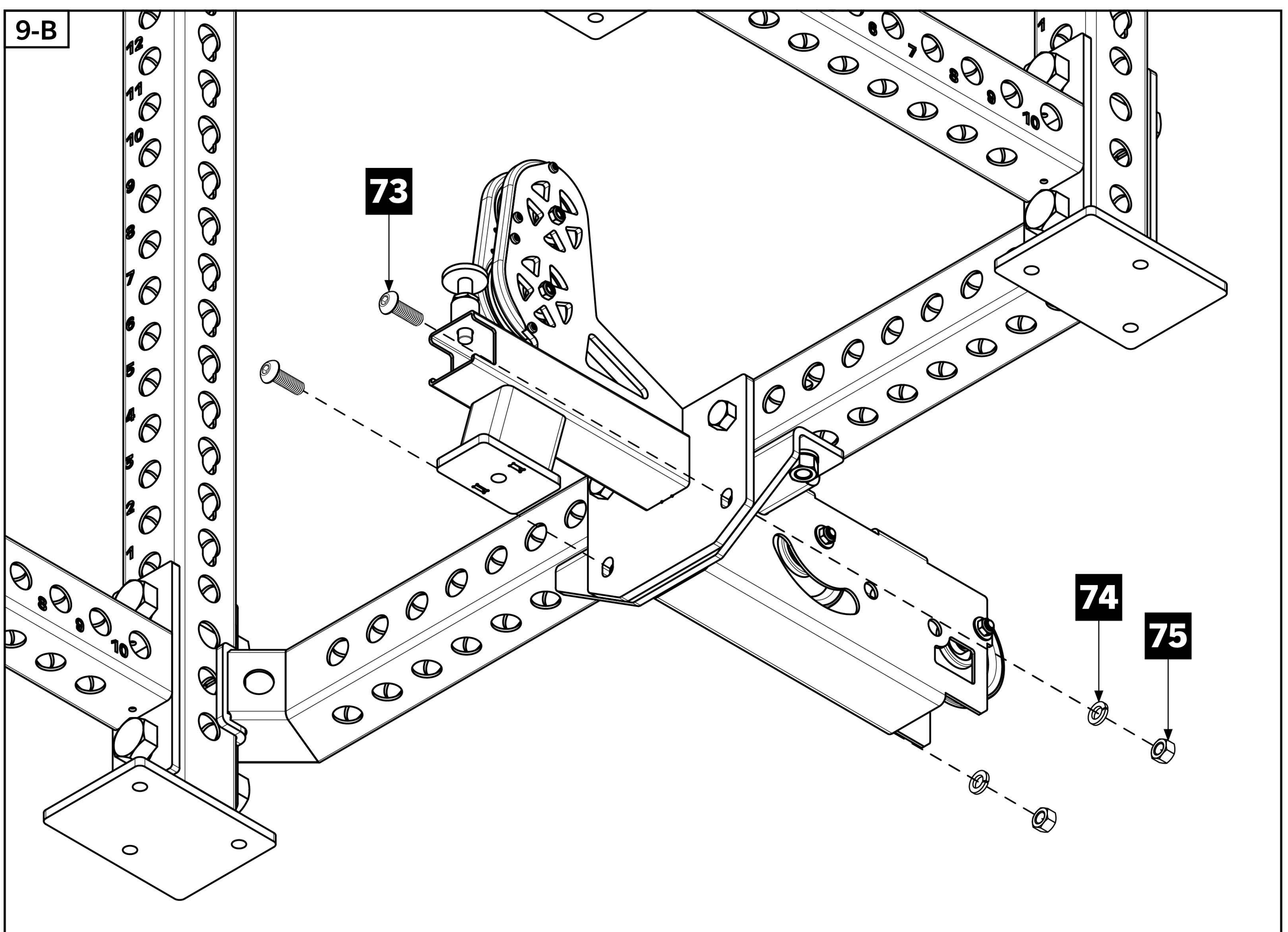
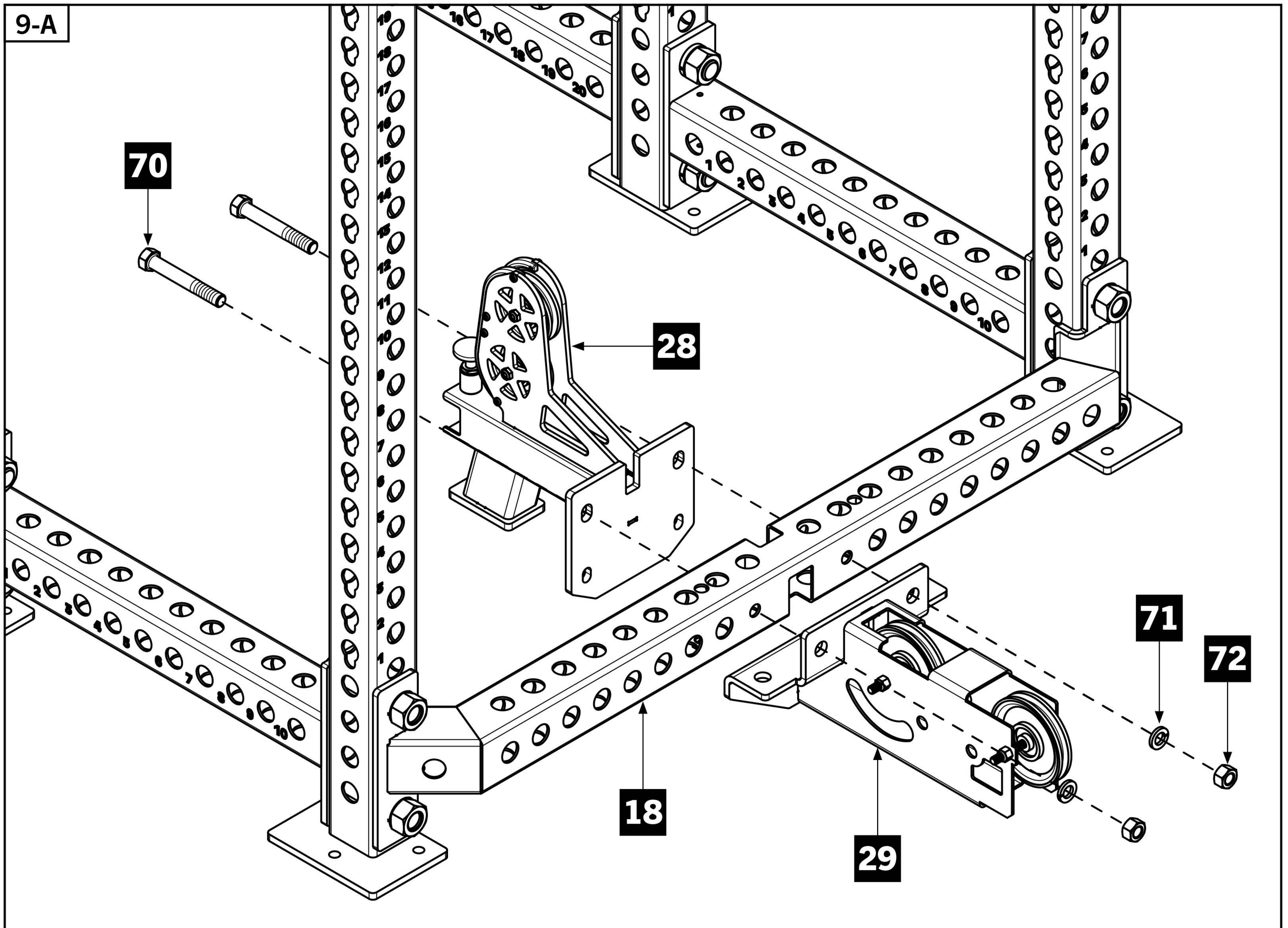
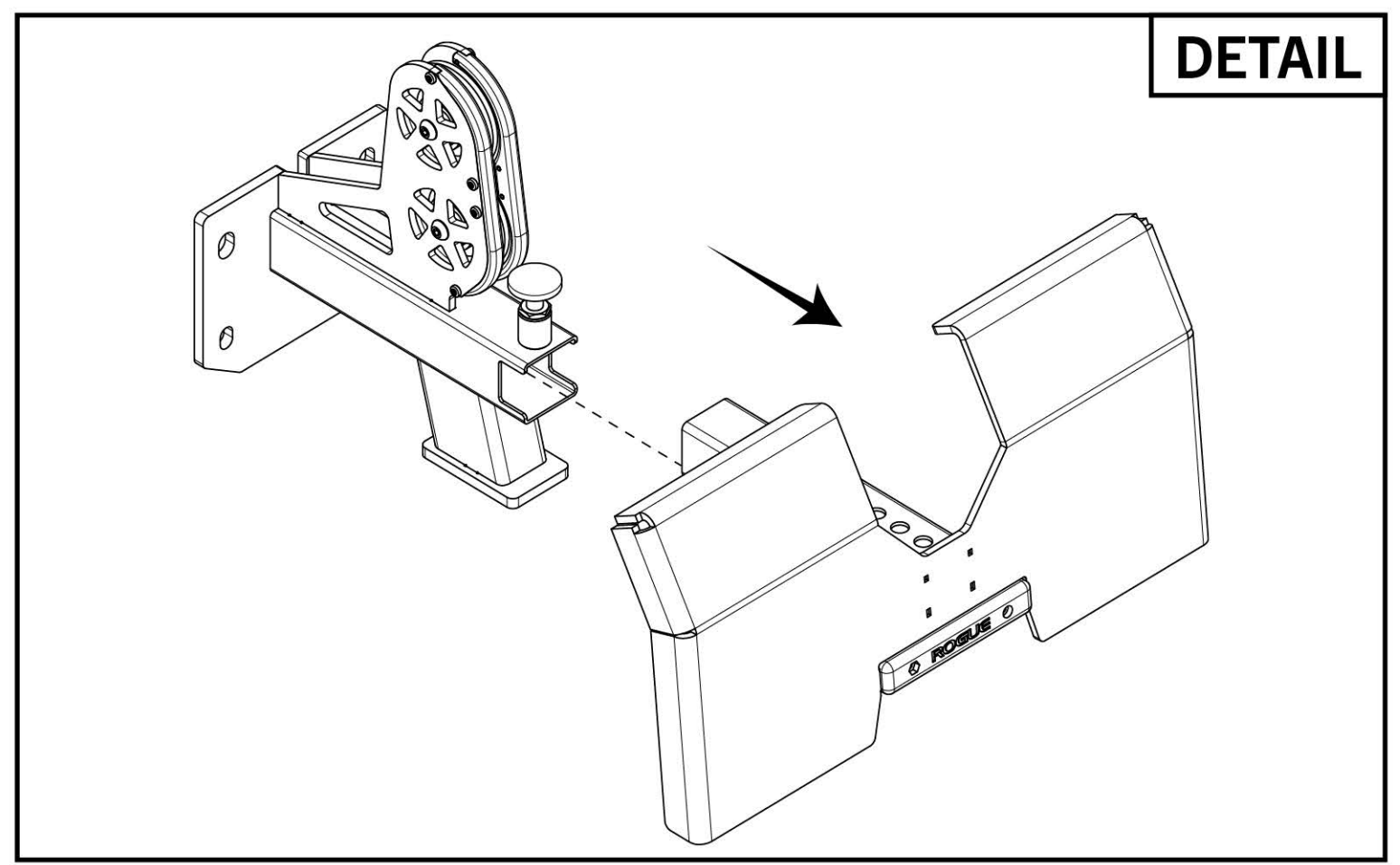

STEP 10

- Align Rear 3X3 Upright [17] to back of Low Rear Pulley Assembly [29]. Footplate should slide under the cutout at the bottom of Pulley Assembly.
- Secure Upright to Pulley Assembly by attaching 5/8" x 4-1/2" Hex Bolts [70], Rear Connector Plates [30], 5/8" Lock Washers [71], and 5/8" Hex Nuts [72].

Note:

- Ensure Rear Connector Plates are installed with the arrow indicator stickers facing outward as shown in 10-B.

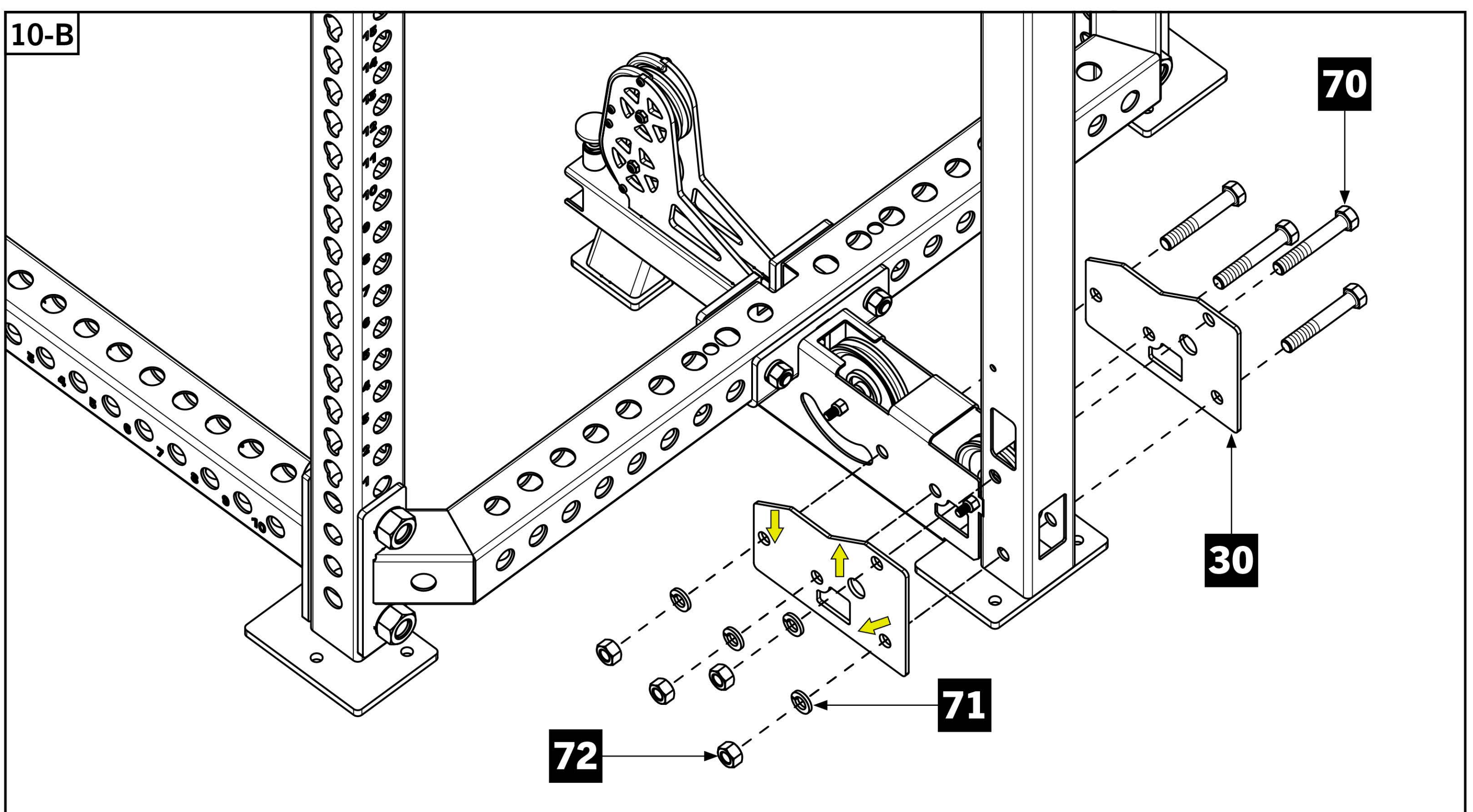
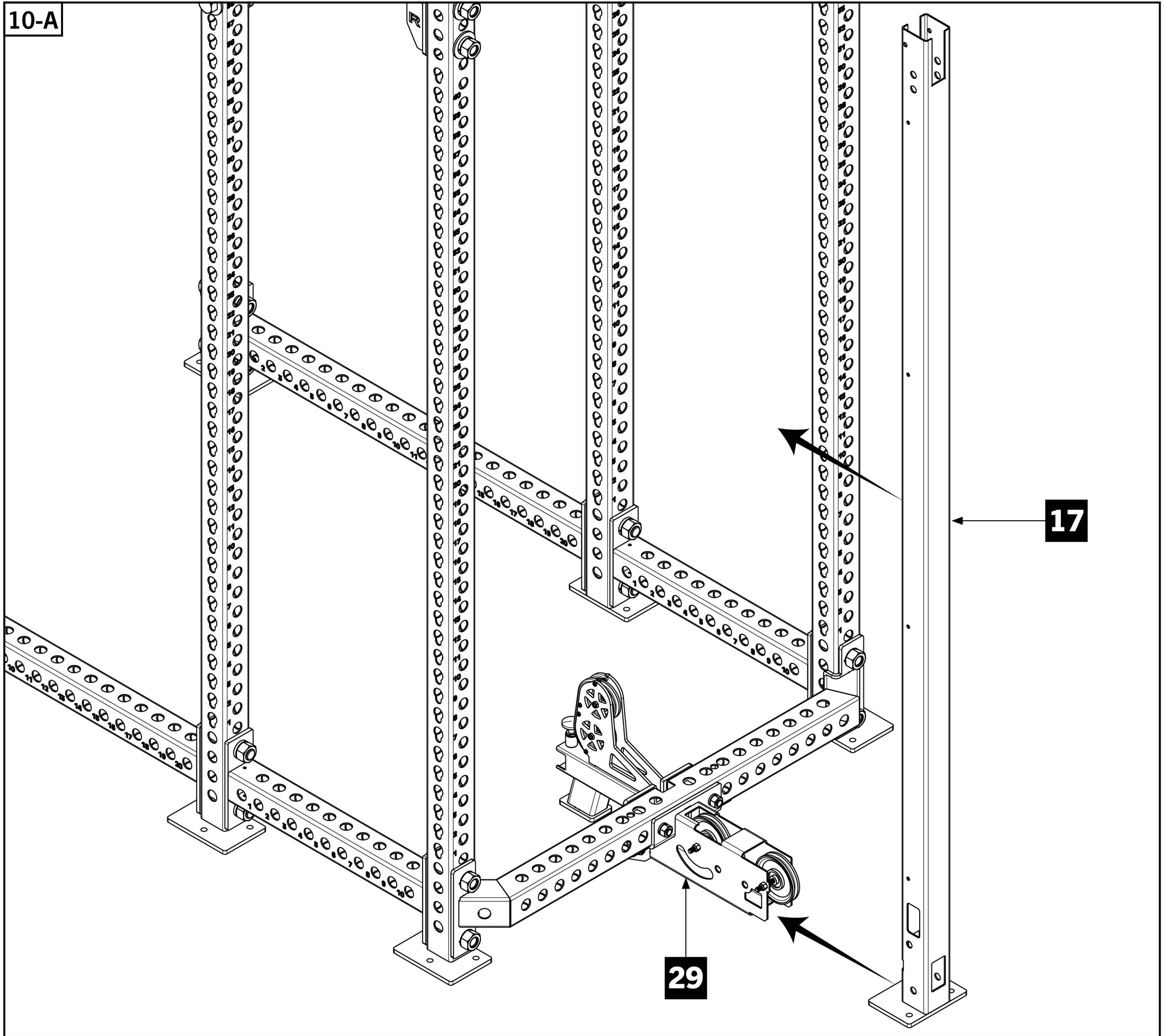

STEP 11

Tools Required:

- 15/16" Wrench
- Attach Weight Stack Shroud Bottom Bracket [82] and Weight Stack Spacer [35] to middle of Low Row Crossmember [18] by using 5/8" x 5" Hex Bolts [69], 5/8" Lock Washers [71], and 5/8" Hex Nuts [72].
- Fully tighten 5/8" vertical hardware in 11-A.

- Place Weight Stack Bumpers [37] over outer 1" holes on the Weight Stack Spacer and insert Guide Rods [31] until they rest on top of the Low Row Crossmember.

Note:

- Shroud Bracket [82] only included if shroud kit was purchased. Simply bolt the Weight Stack Spacer using hardware shown if shrouds were not purchased.

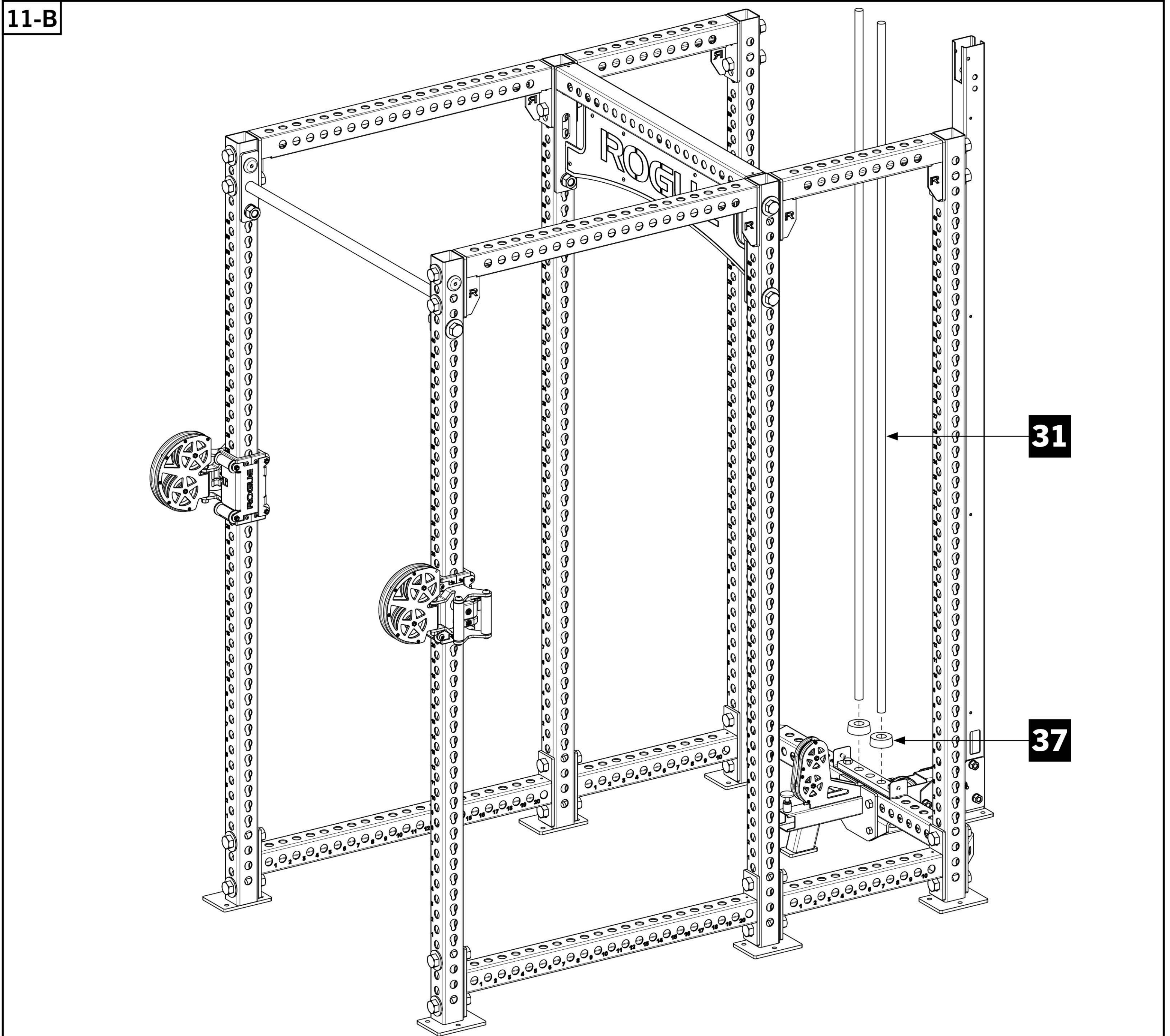
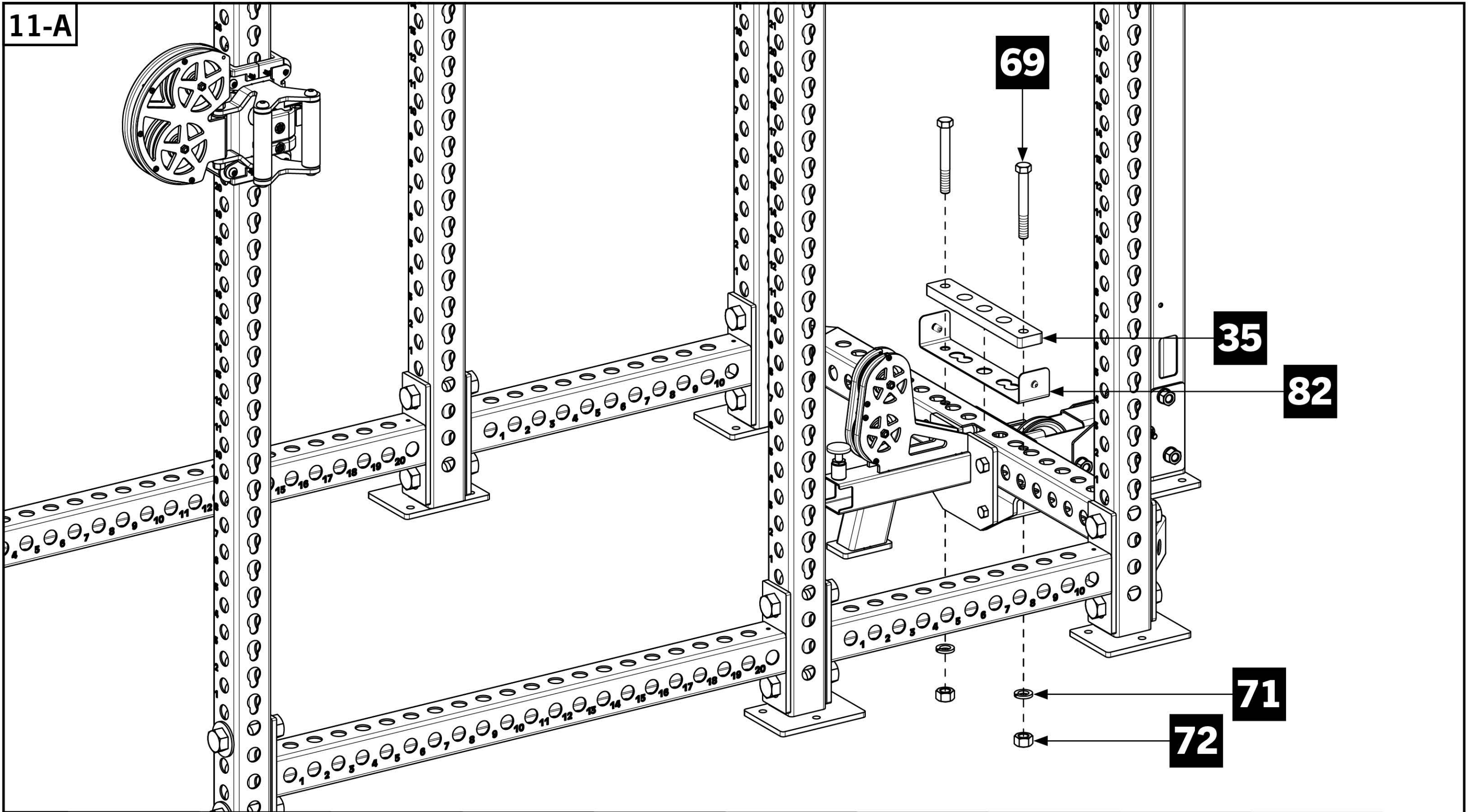

STEP 12

- Angle the Guide Rods toward the front of the rack.
- One at a time, carefully stack all included 10LB Weight Stack Plates [33] down the Guide Rods [31], ensuring not to drop them.
- **Note:** this is best accomplished with two or three people.
- Once all weights are stacked, slide the Weight Stack Stem [32] down the Guide Rods until resting on top of weight stack.
- Ensure 20LB Weight Stack Sticker on the top Plate of the stack is facing towards the front of rack as shown in Detail view.

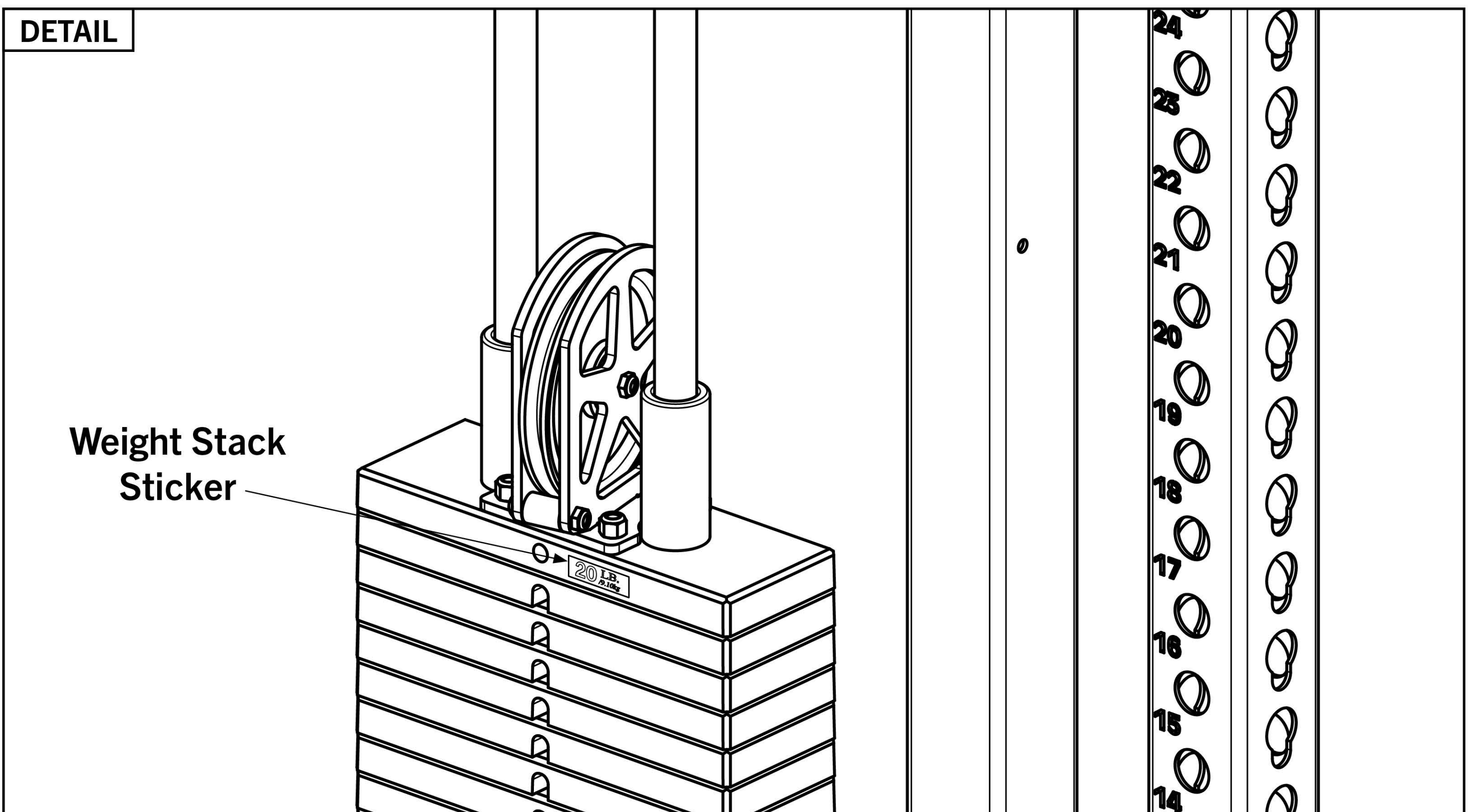
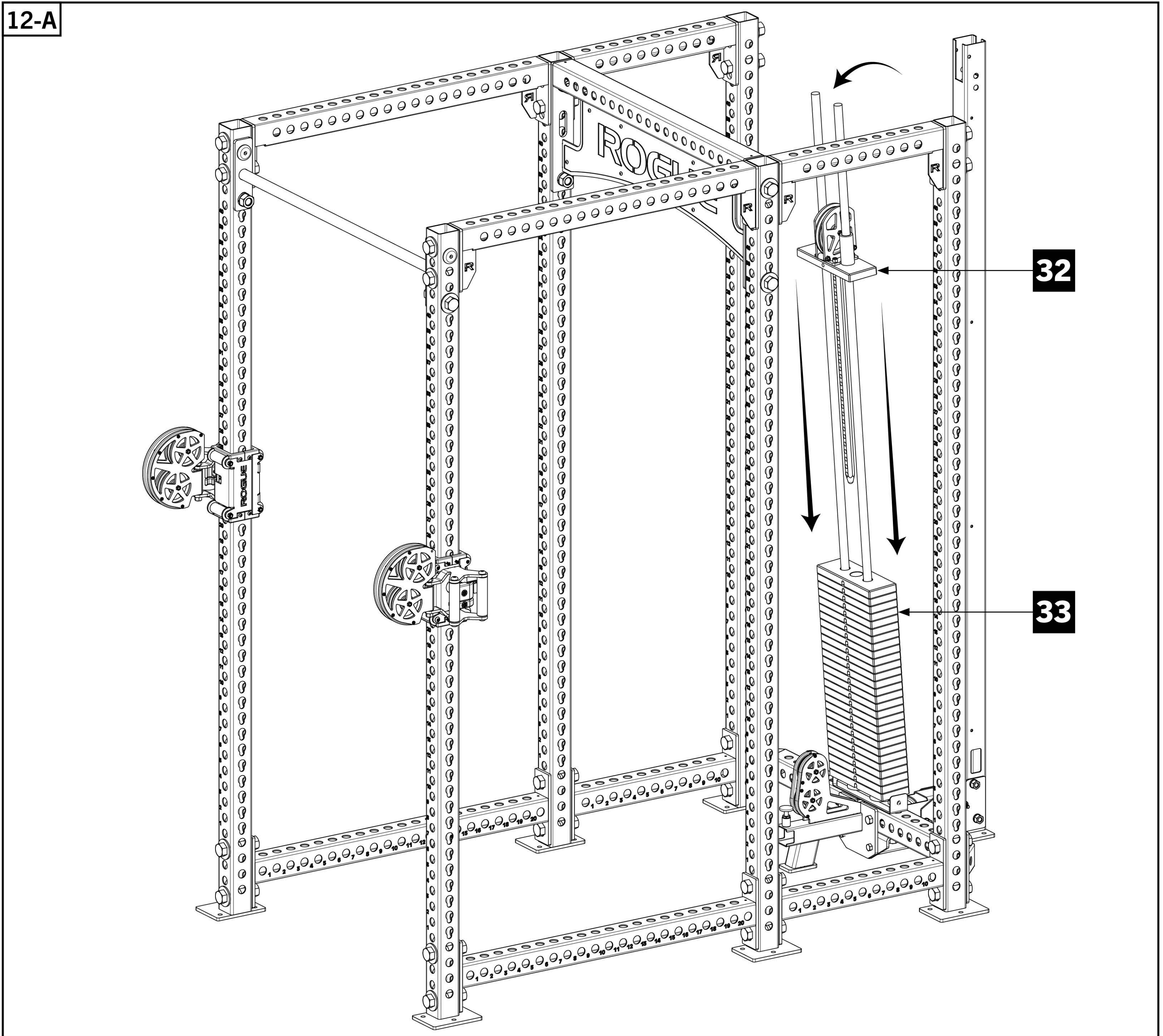

STEP 13

- Slide Top Weight Stack Stop Block [36] and Guide Rod Spacers [38] down guide rods and rest on top of Weight Stack Stem Pulley as shown.

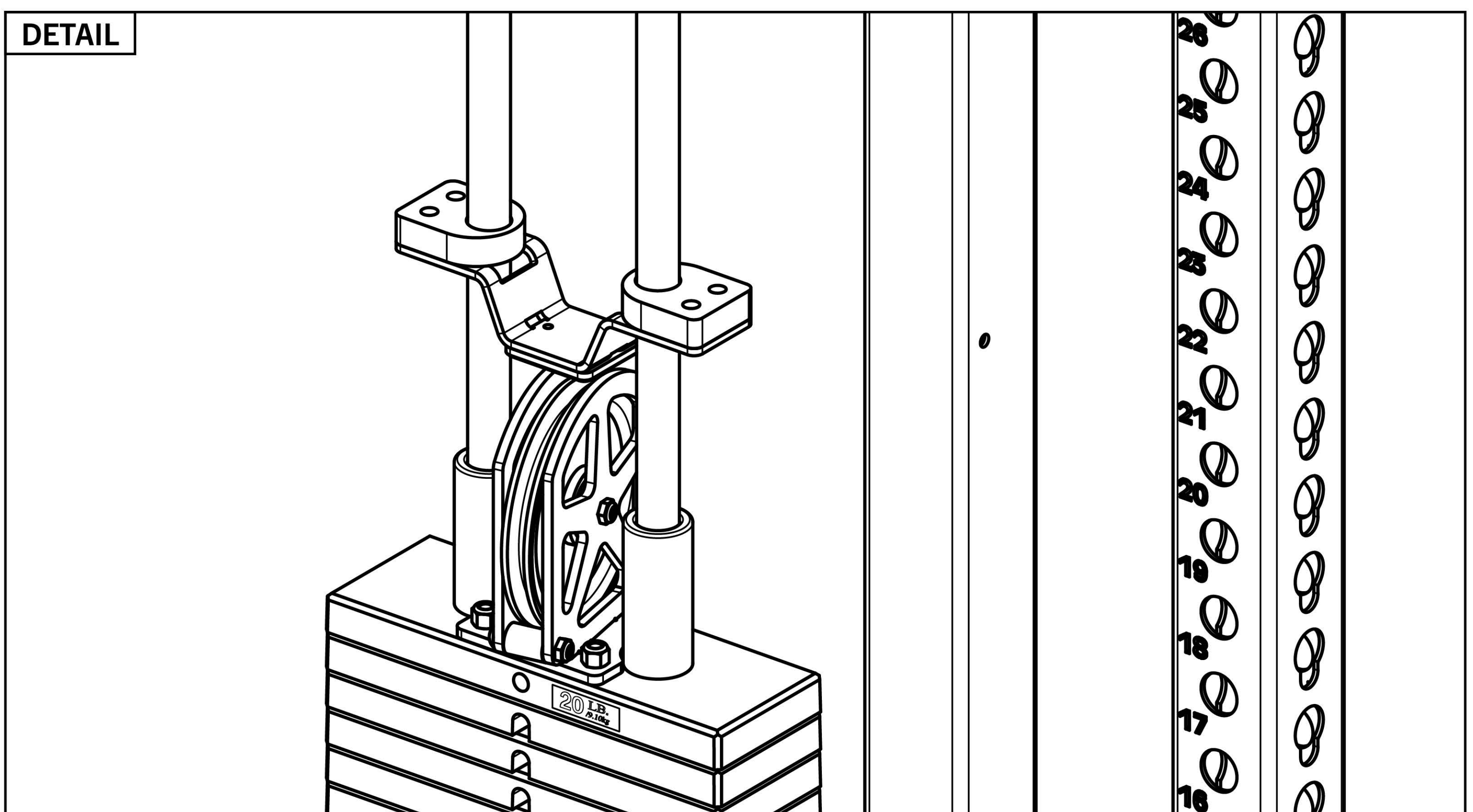
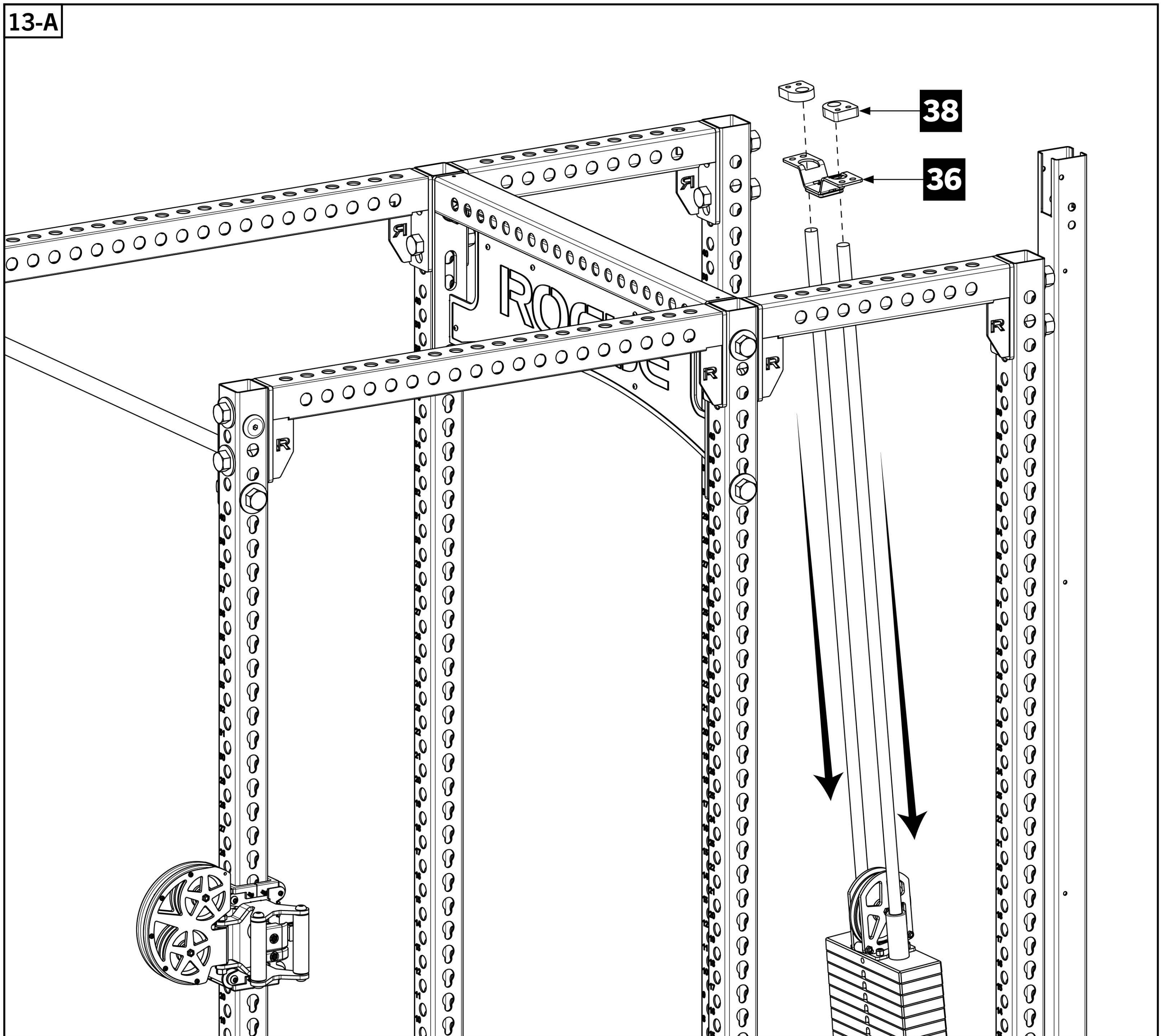

STEP 14

- Assemble Top Rear Angle Crossmember - RH [22] into position on rear of rack as shown.
- Assemble Top Rear Angle Crossmember - LH [23].
- Ensure Angle Crossmembers are properly locked into Rear 3X3 Upright [17] as shown on next page.

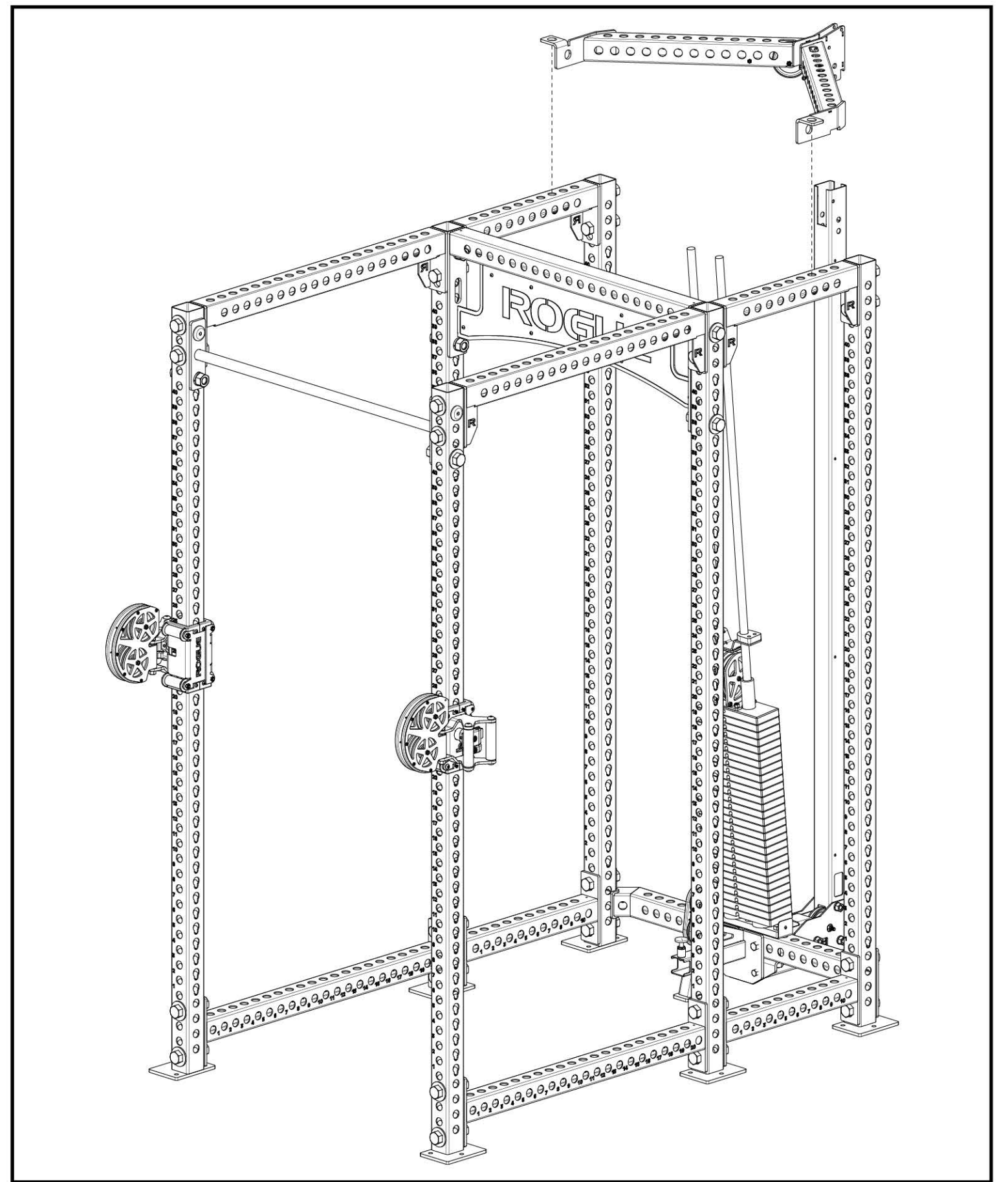

14-A

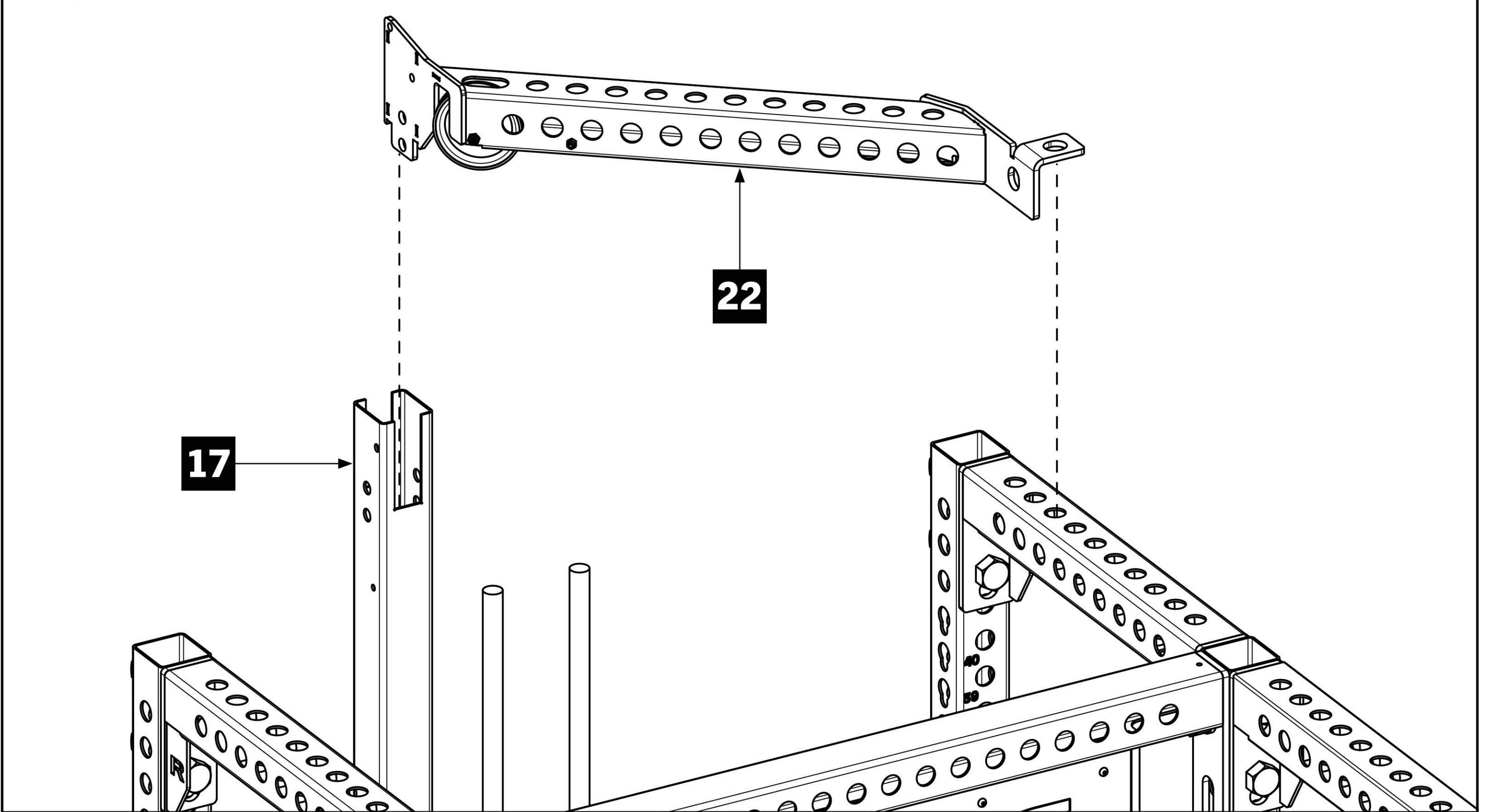

14-B

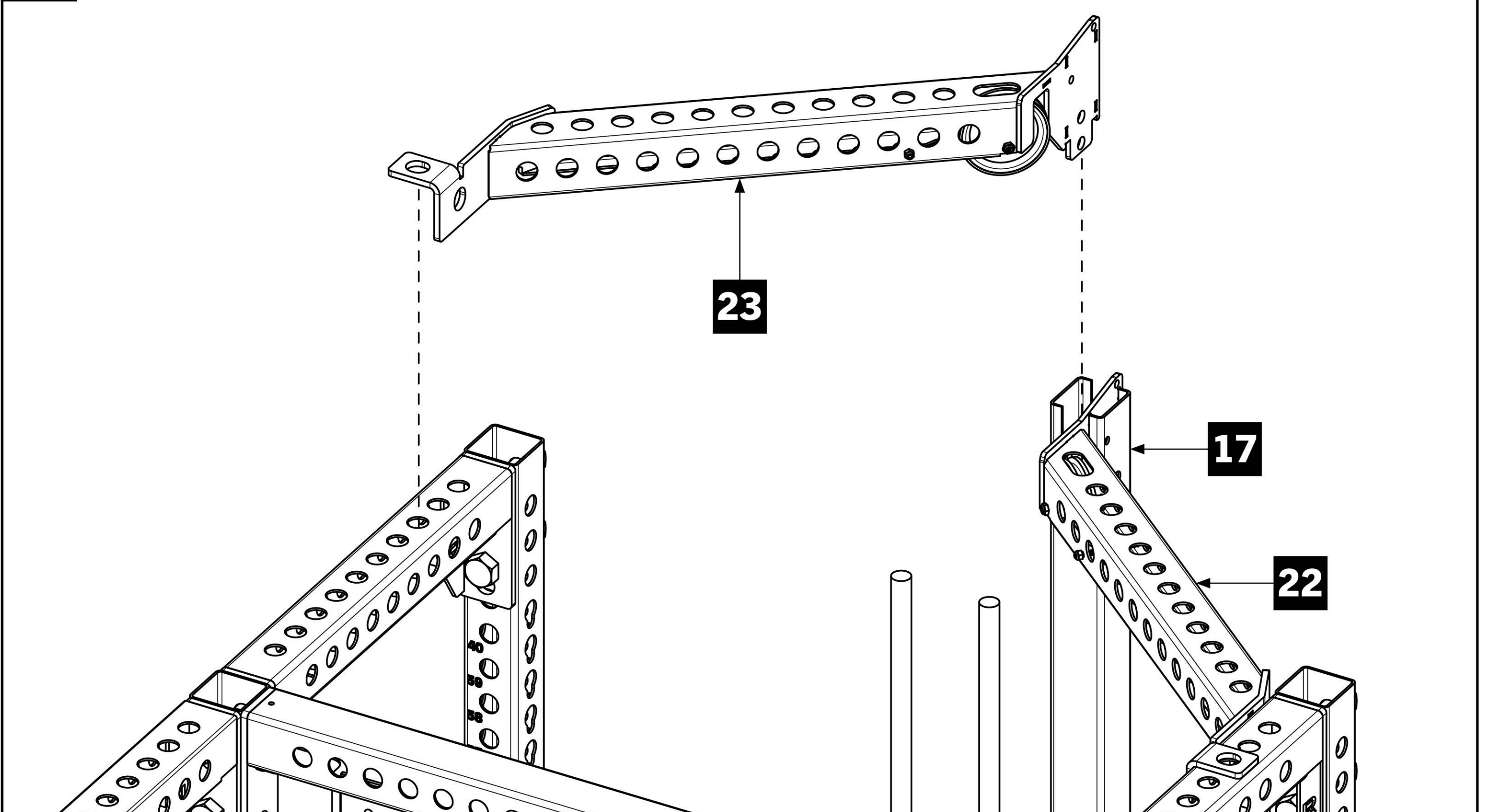

STEP 14 (CONTINUED)

- Secure Angle Crossmembers to Rear Top Crossmembers using 1" x 5" Hex Bolts [64], Side Shroud Top Brackets [87], 1" Lock Washers [67], and 1" Hex Nuts [68].

Note:

- Use 1" Flat Washers [66] instead of Side Shroud Top Brackets if Shroud Kit was not purchased.

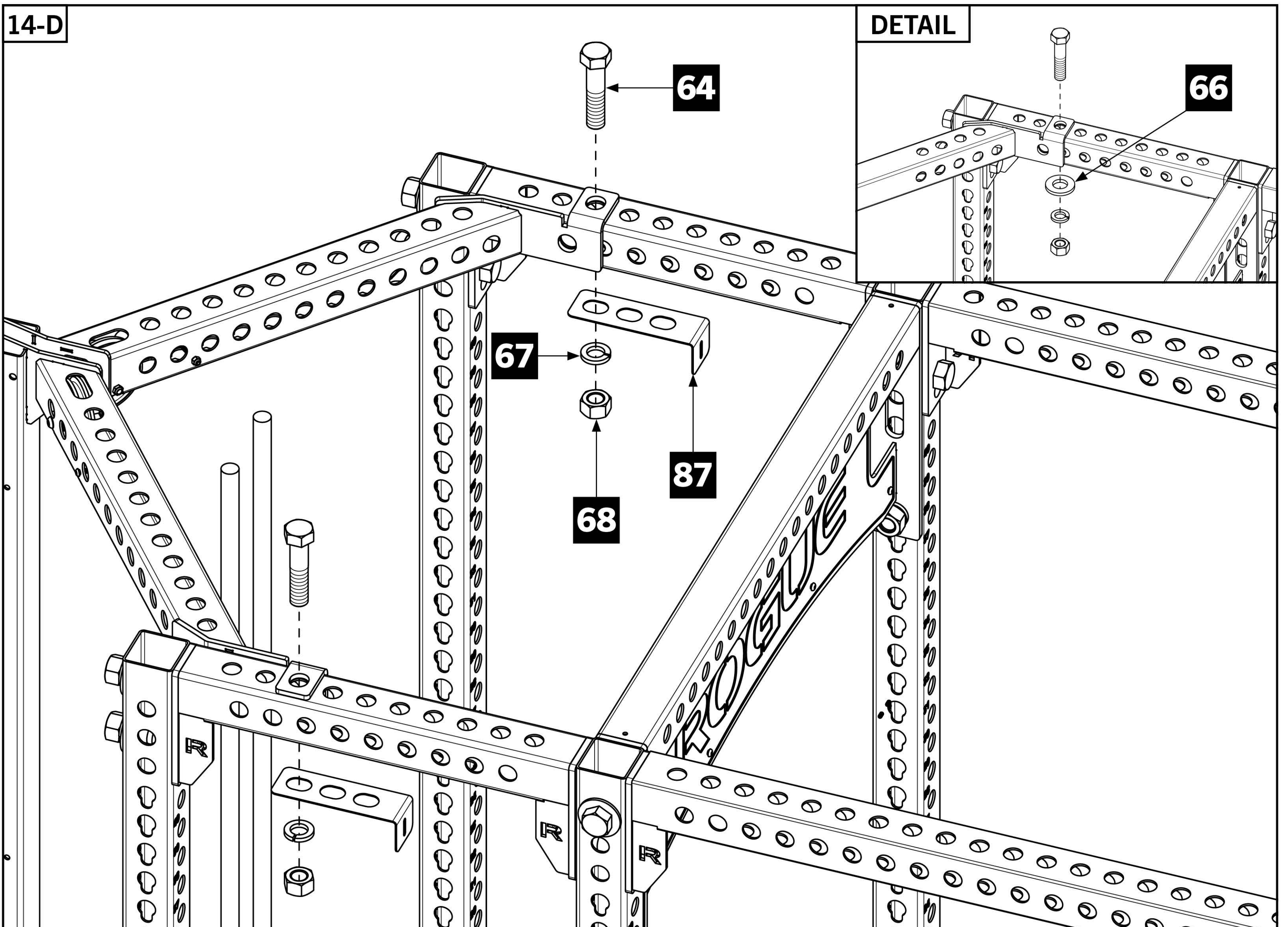
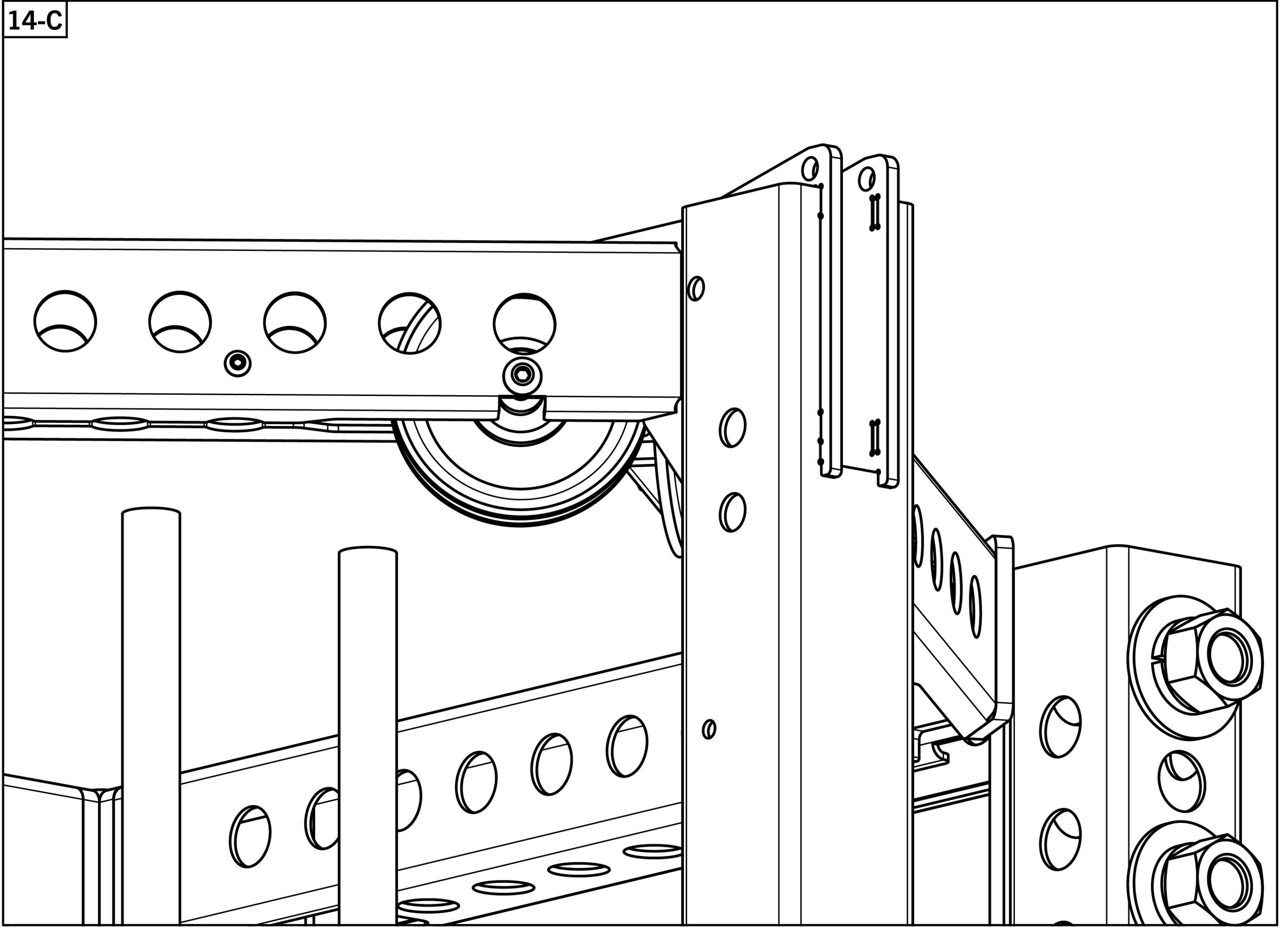

STEP 15

• Bolt Lat Bar Hanger [27], Lat Pulldown Pulley Bracket [26], and Top Center Crossmember [21] to Nameplate Crossmember [21] using 1" x 5" Hex Bolts [64], 1" Lock Washers [67], and 1" Hex Nuts [68] as shown in 15-A.

• Bolt Top Rear Connector Plates RH [24] and LH [25] to Top Center Crossmember [21] and Rear 3X3 Upright [17] using 5/8" x 4-1/2" Hex Bolts [70], 5/8" Lock Washers [71], and 5/8" Hex Nuts [72].

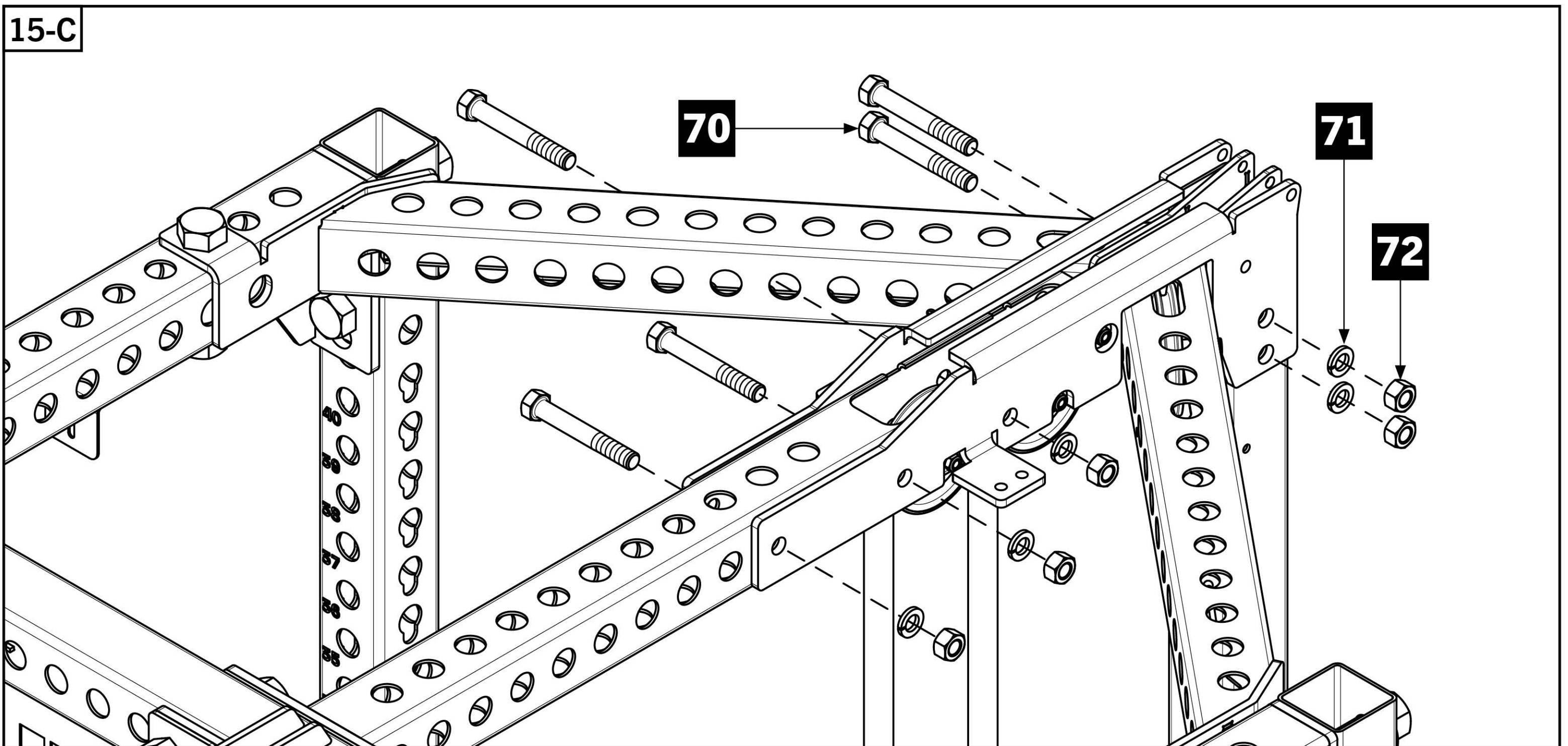
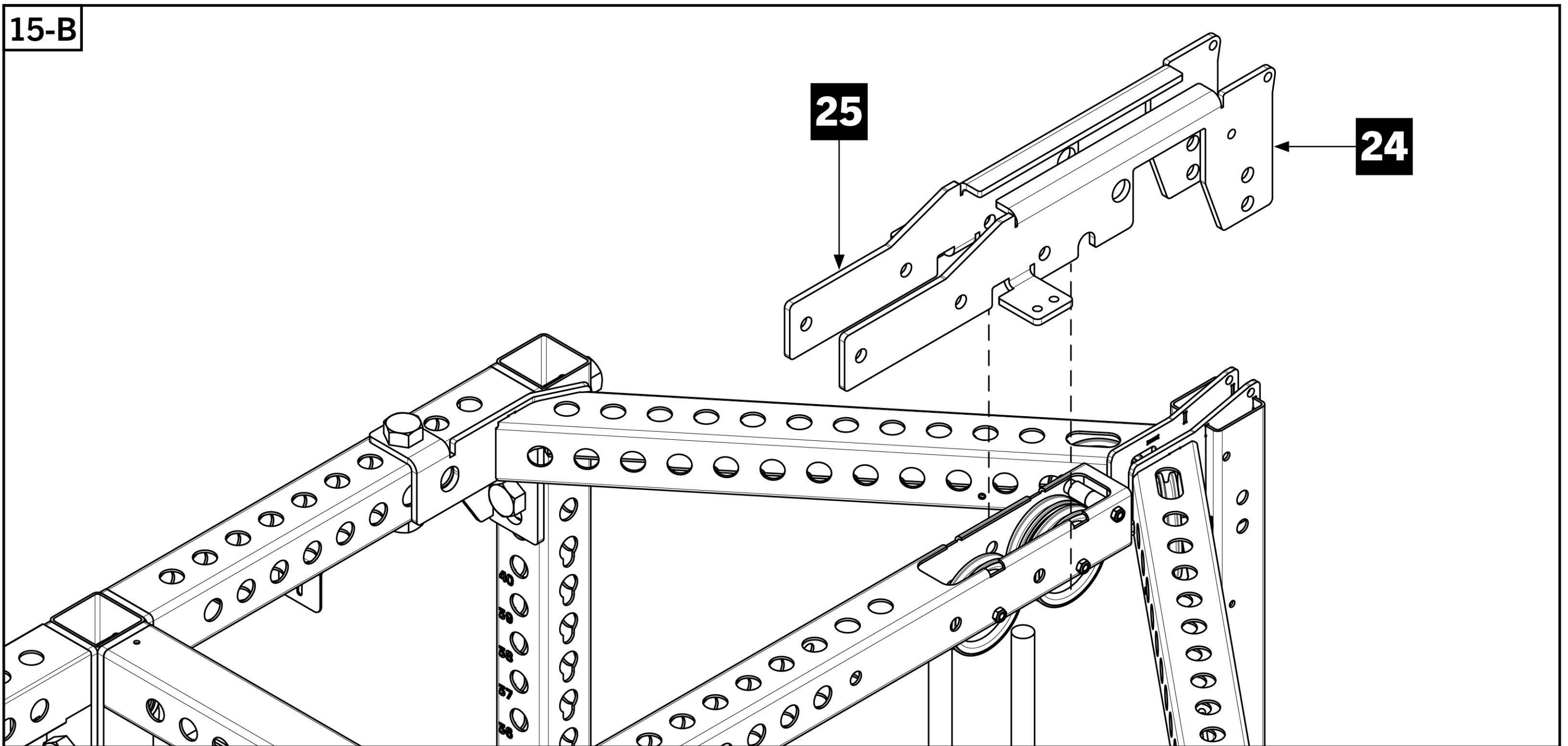
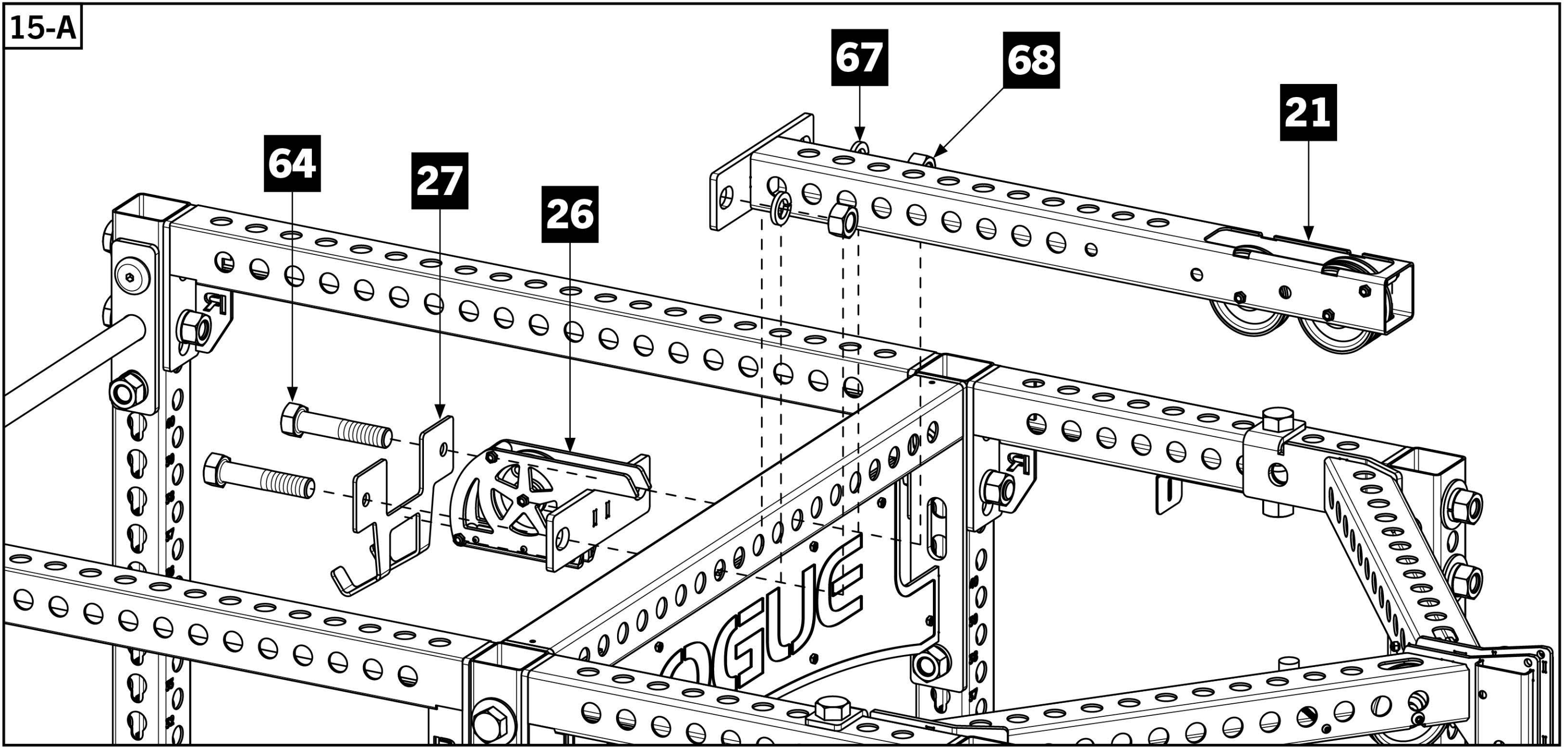

STEP 16

- Secure 4.5" Pulley [51] and 3/4" x 1" Cable Retainer [52] inside top rear center slot of the of the assembly using 3/8" x 4" Button Head Screws [76] and 3/8" Thin Nylock Nuts [78] through the indicated holes.

- Slide parts assembled in **Step 13** back up to the top of the Guide Rods.

- Bolt Stop Block assembly to indicated holes on Top Rear Connector Plates [24] and [25] using 3/8" x 1.5" Button Head Screws [77] and 3/8" Thin Nylock Nuts [78].

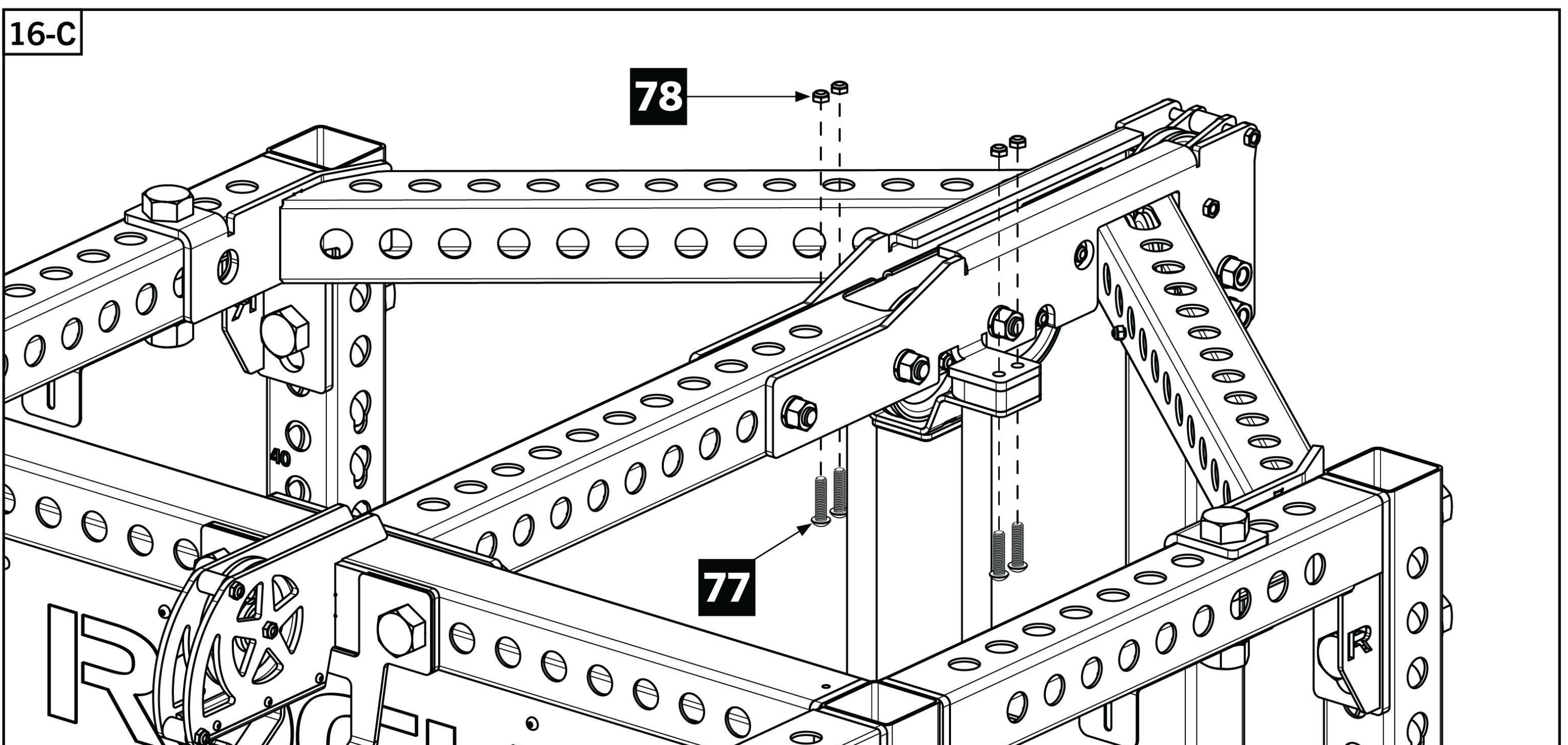
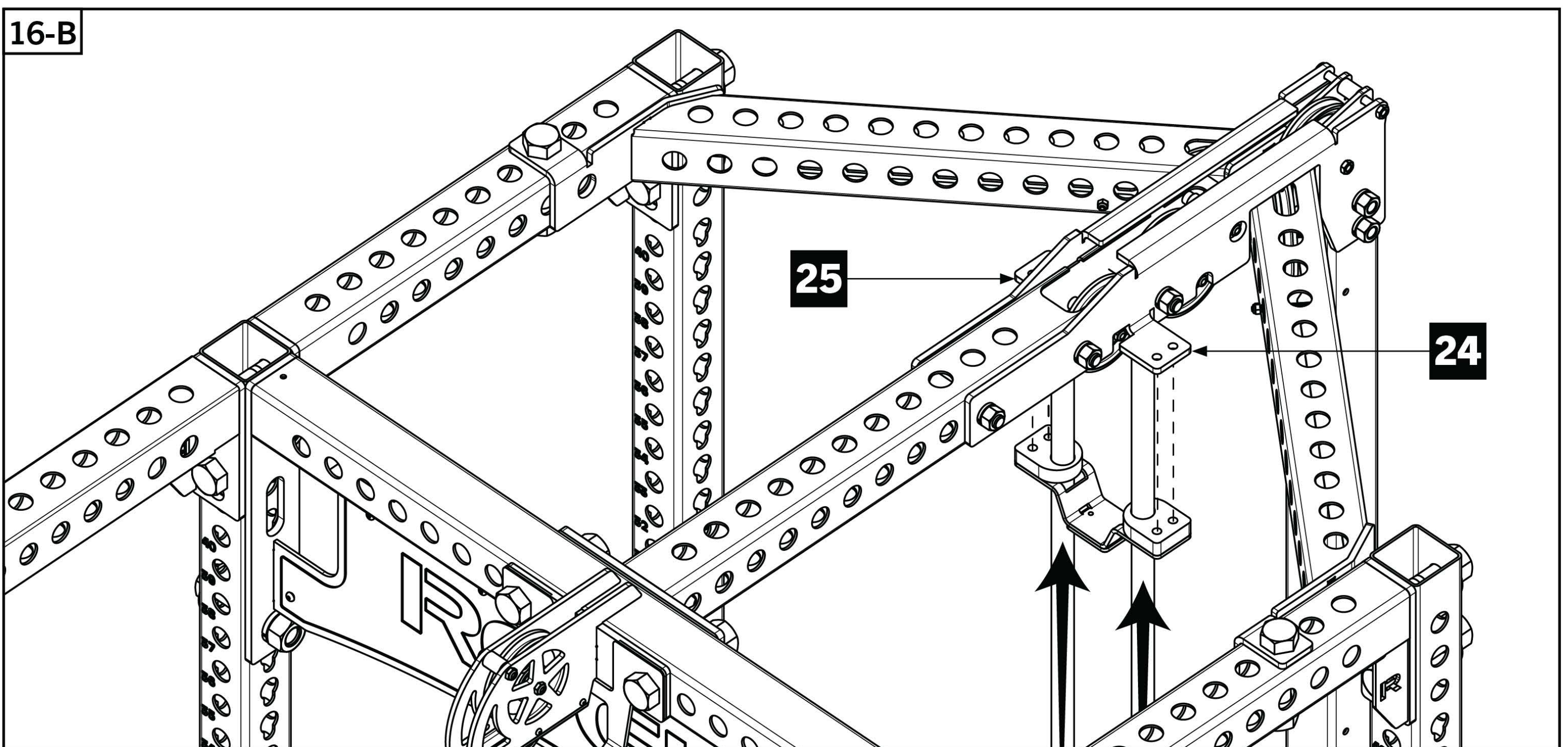
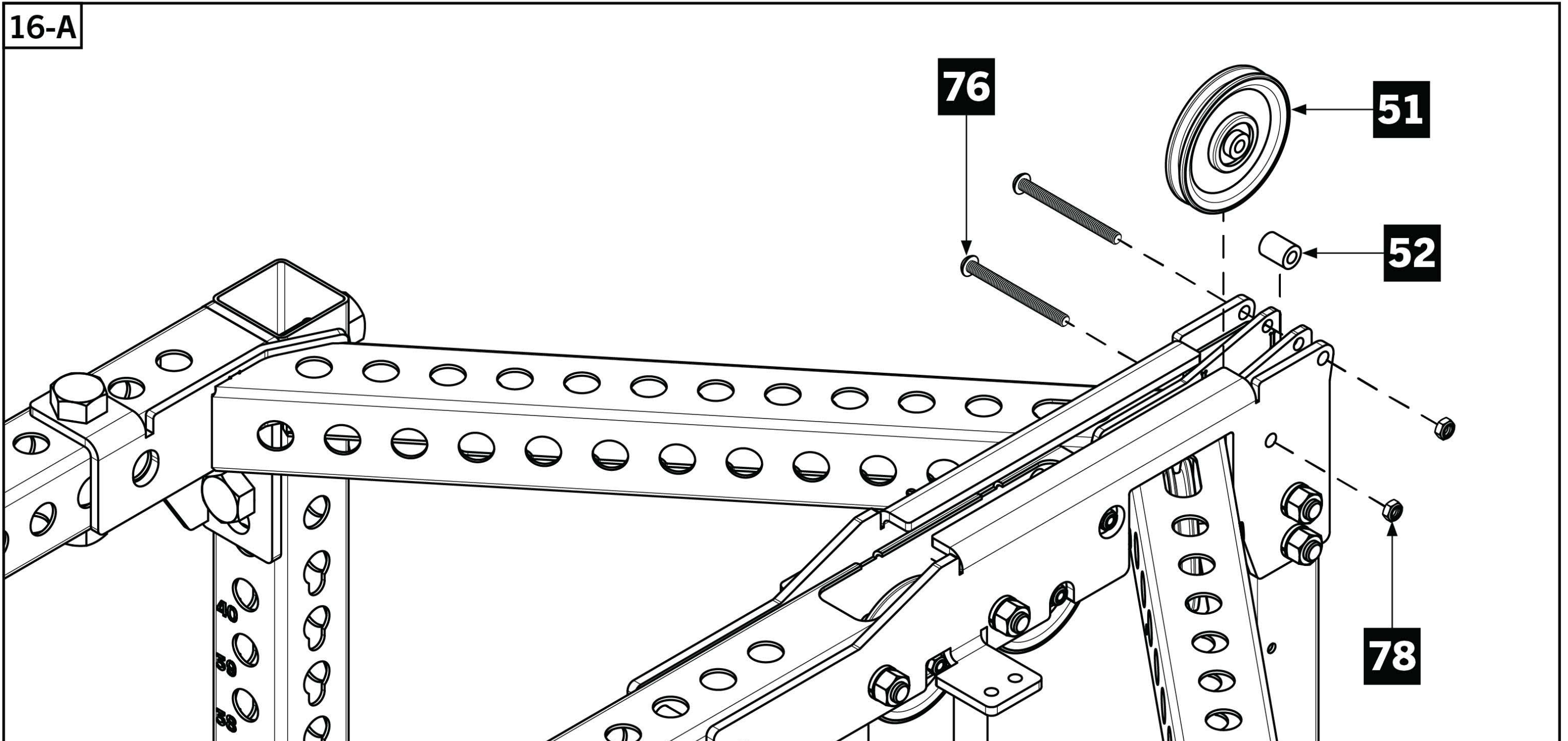

STEP 17

- Bolt Top Front Side Pulley Assembly - RH [41] and -LH [42] to the Front Top Crossmembers using 1" x 5" Hex Bolts [64], 1" x 3/8" Pulley Bracket Spacers [65], 1" Flat Washers [66], 1" Lock Washers [67], and 1" Hex Nuts [68] as shown.

- **!** 43" Front Top Crossmember is shown. The Top Front Side Pulley Assembly holes utilized will depend on length of your Front Crossmembers. Use the diagram below to determine which holes to use.

Note:

- Bolt hardware through the first and third holes on your Front Top Crossmembers [2] regardless of crossmember length.

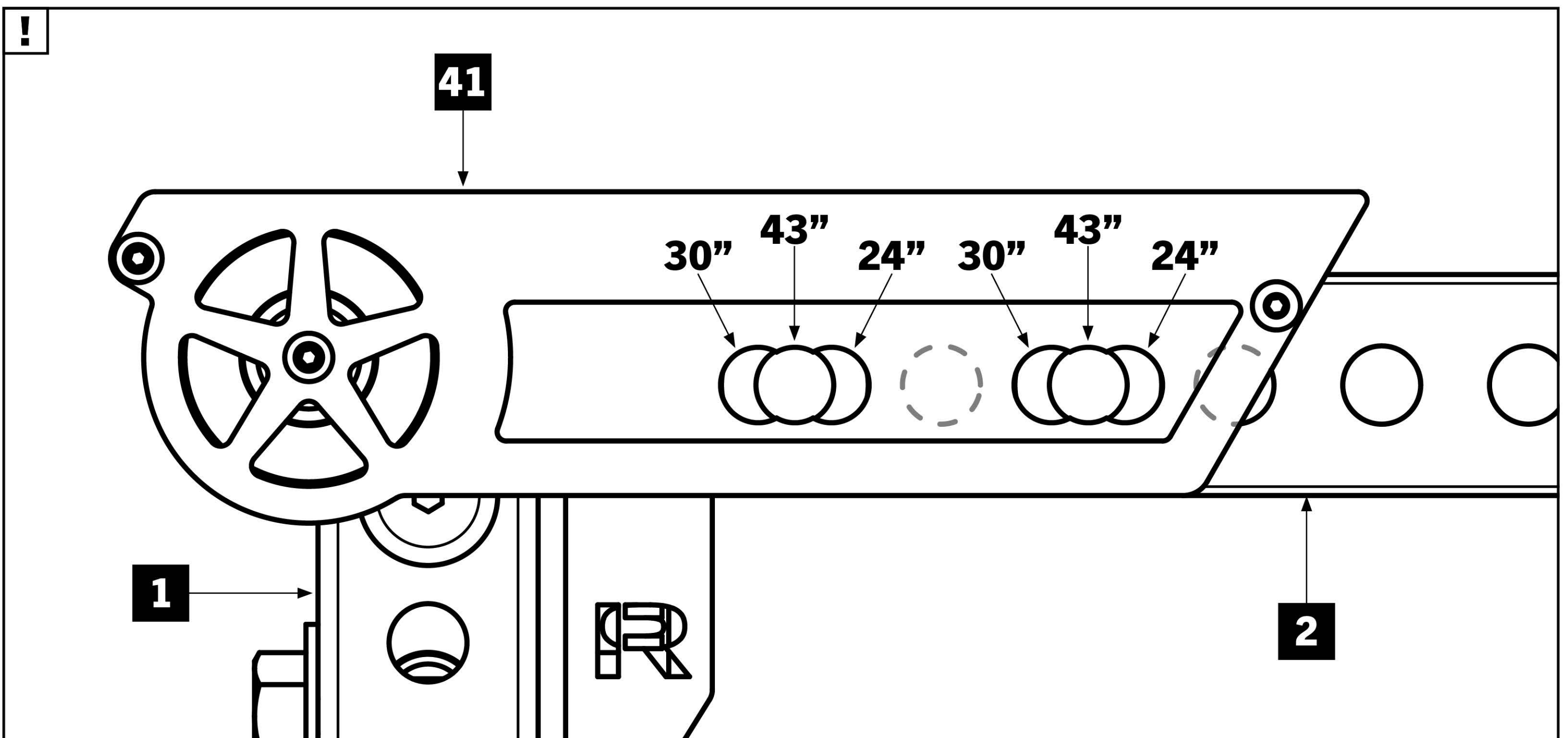
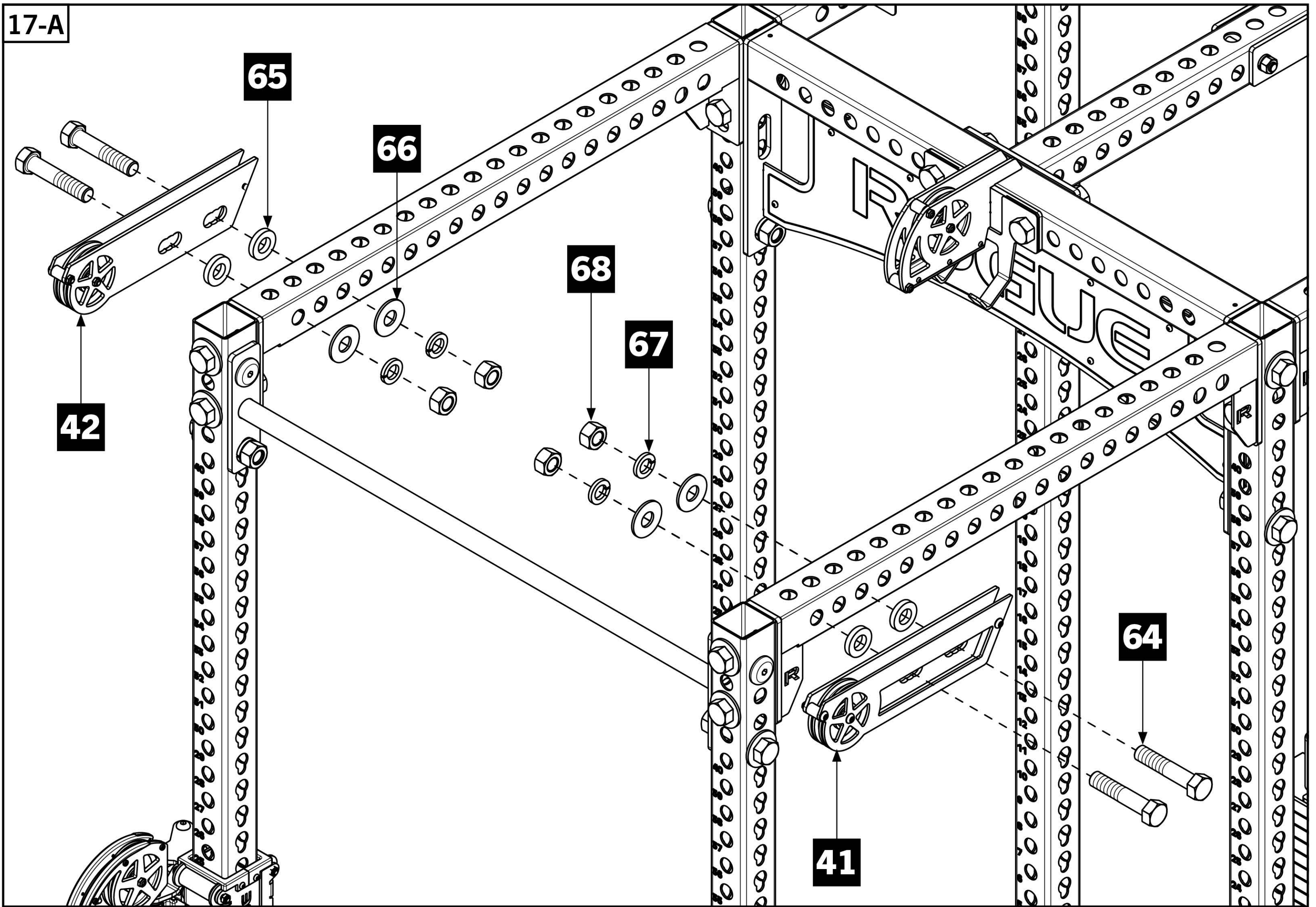
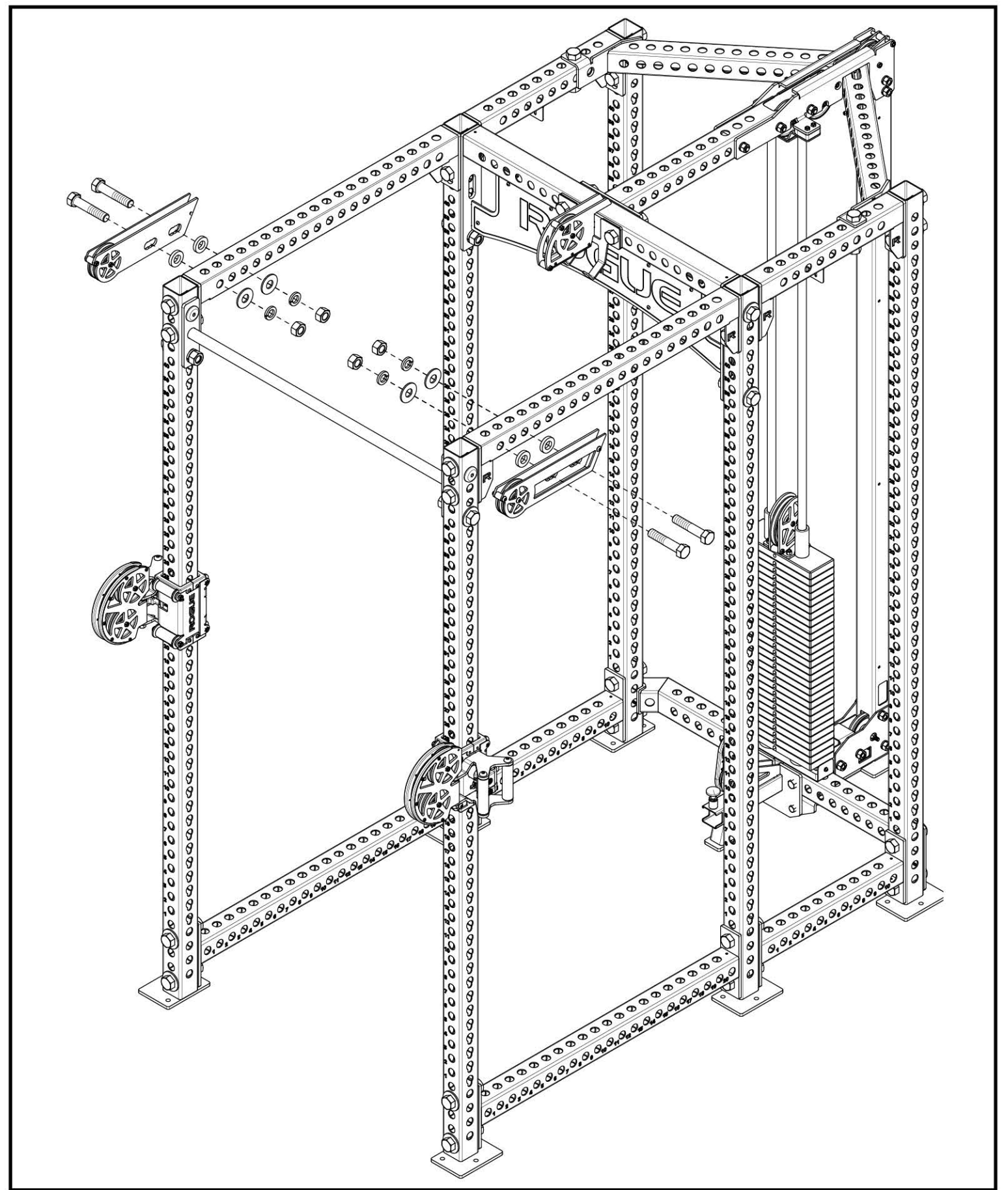

STEP 18

- Bolt Top Rear Side Pulley Assembly - RH [43] and -LH [44] to the 24" Rear Top Crossmembers [4] using 1" x 5" Hex Bolts [64], 1" x 3/8" Pulley Bracket Spacers [65], 1" Flat Washers [66], 1" Lock Washers [67], and 1" Hex Nuts [68] as shown.

- Ensure the rear hardware is assembled through the indicated hole on Top Rear Angled Crossmembers.

Note:

- Only two 1" Flat Washers used on this step. Do not use Flat Washers on the rear hardware assemblies.
- Tip: it is easiest to assemble this step by inserting the front hardware first and then swinging the back of Side Pulley Assemblies up to install the rear hardware.

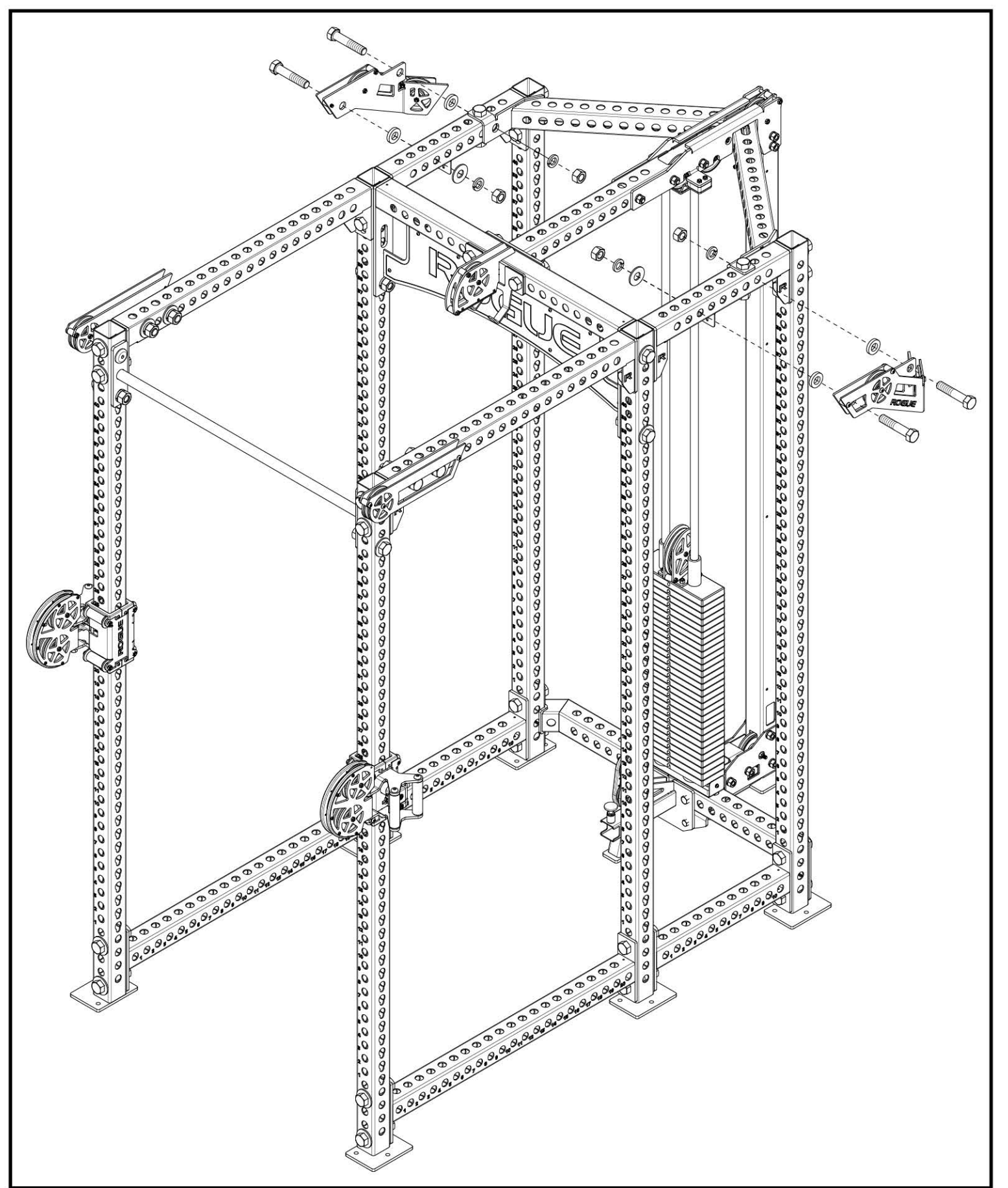

18-A

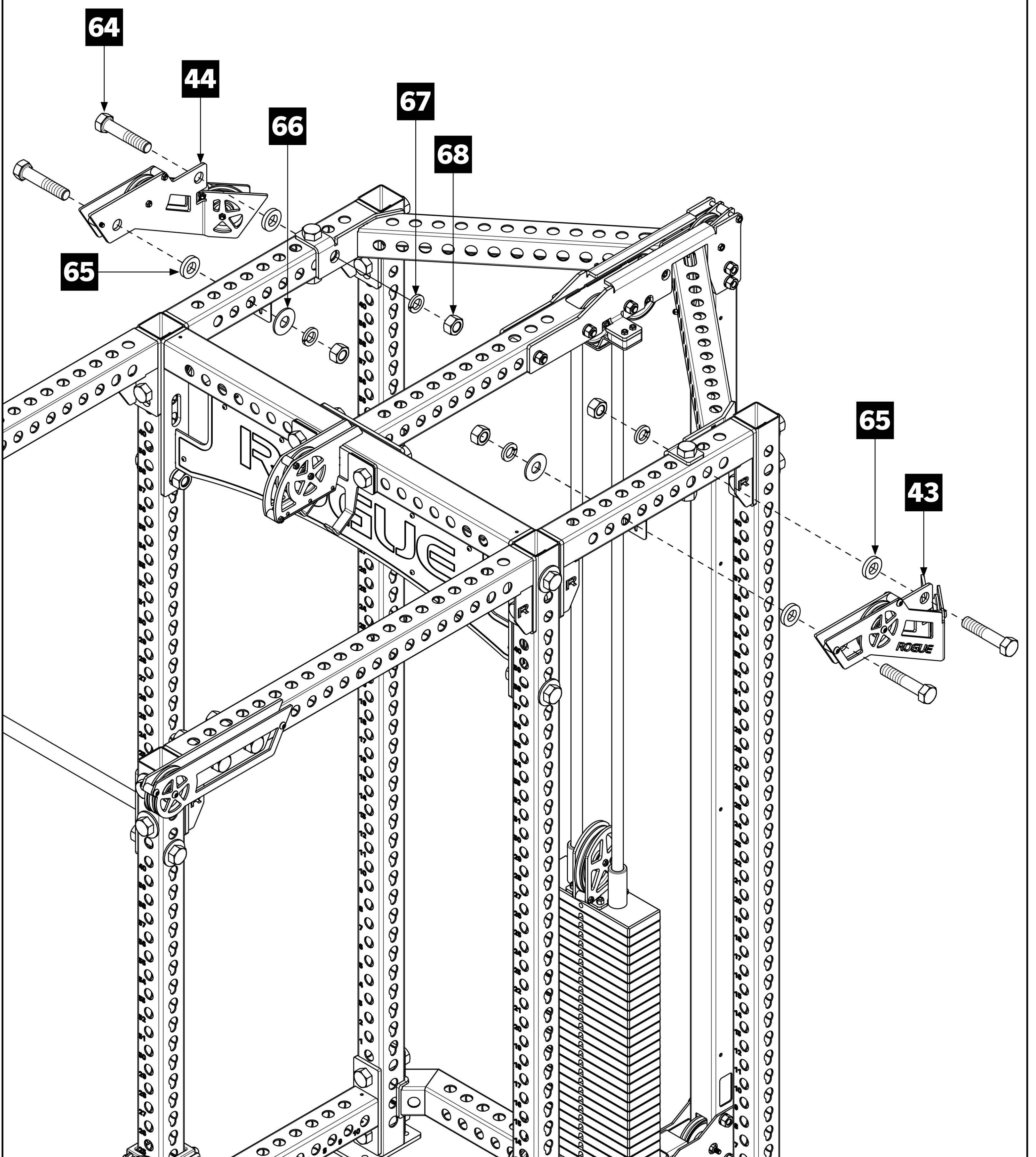

STEP 19

- Bolt Bottom Front Side Pulley Assembly - RH [45] and -LH [46] to the Front Low Crossmembers using 1" x 5" Hex Bolts [64], 1" x 3/8" Pulley Bracket Spacers [65], 1" Flat Washers [66], 1" Lock Washers [67], and 1" Hex Nuts [68] as shown.

- **!** 43" Front Top Crossmember is shown. The Bottom Front Side Pulley Assembly holes utilized will depend on length of your Front Crossmembers. Use the diagram below to determine which holes to use.

Note:

- Bolt hardware through the holes between number cutouts '4' & '5' and '6' & '7' on your Front Low Crossmembers [3].
- Bolt heads should be oriented on the inside of rack as shown.

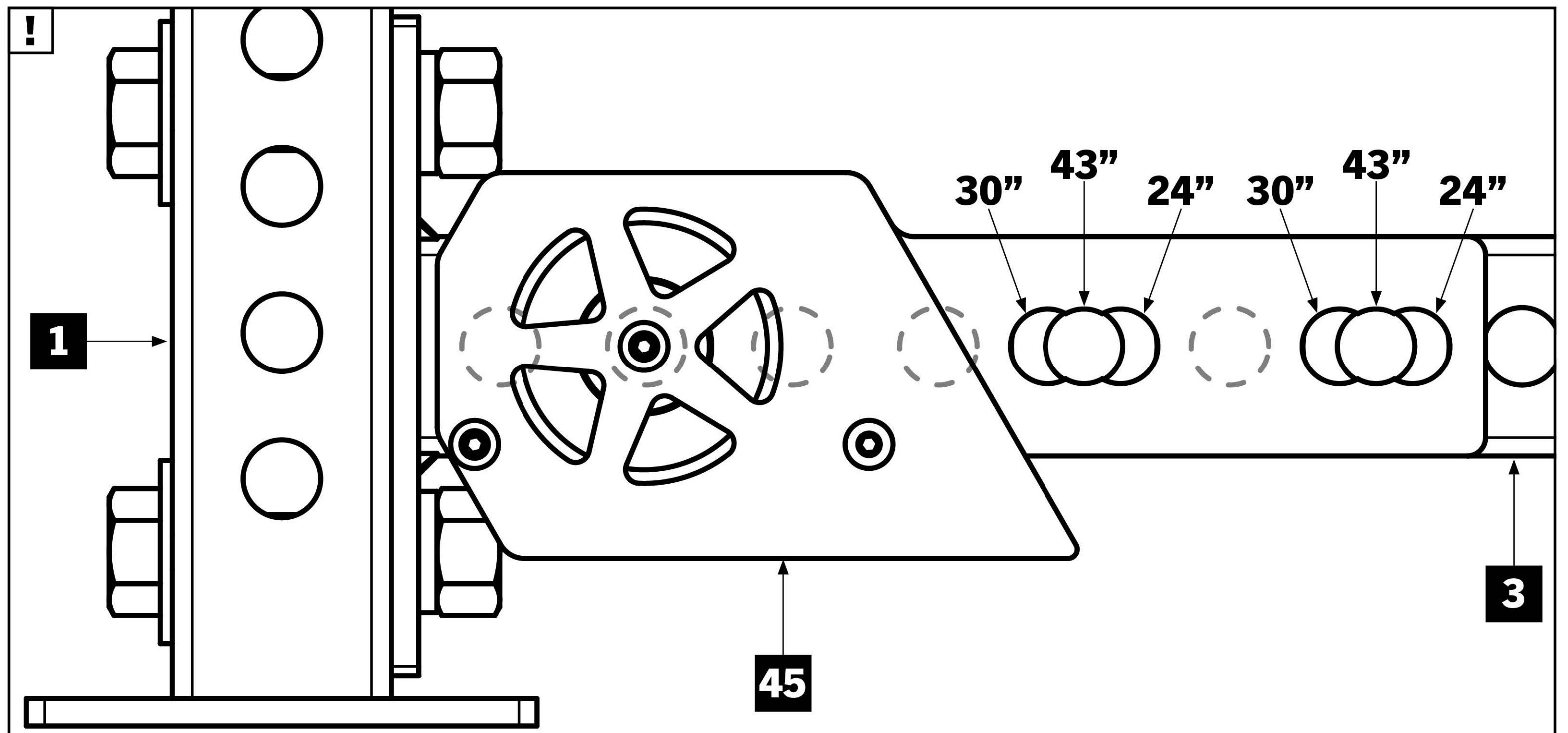
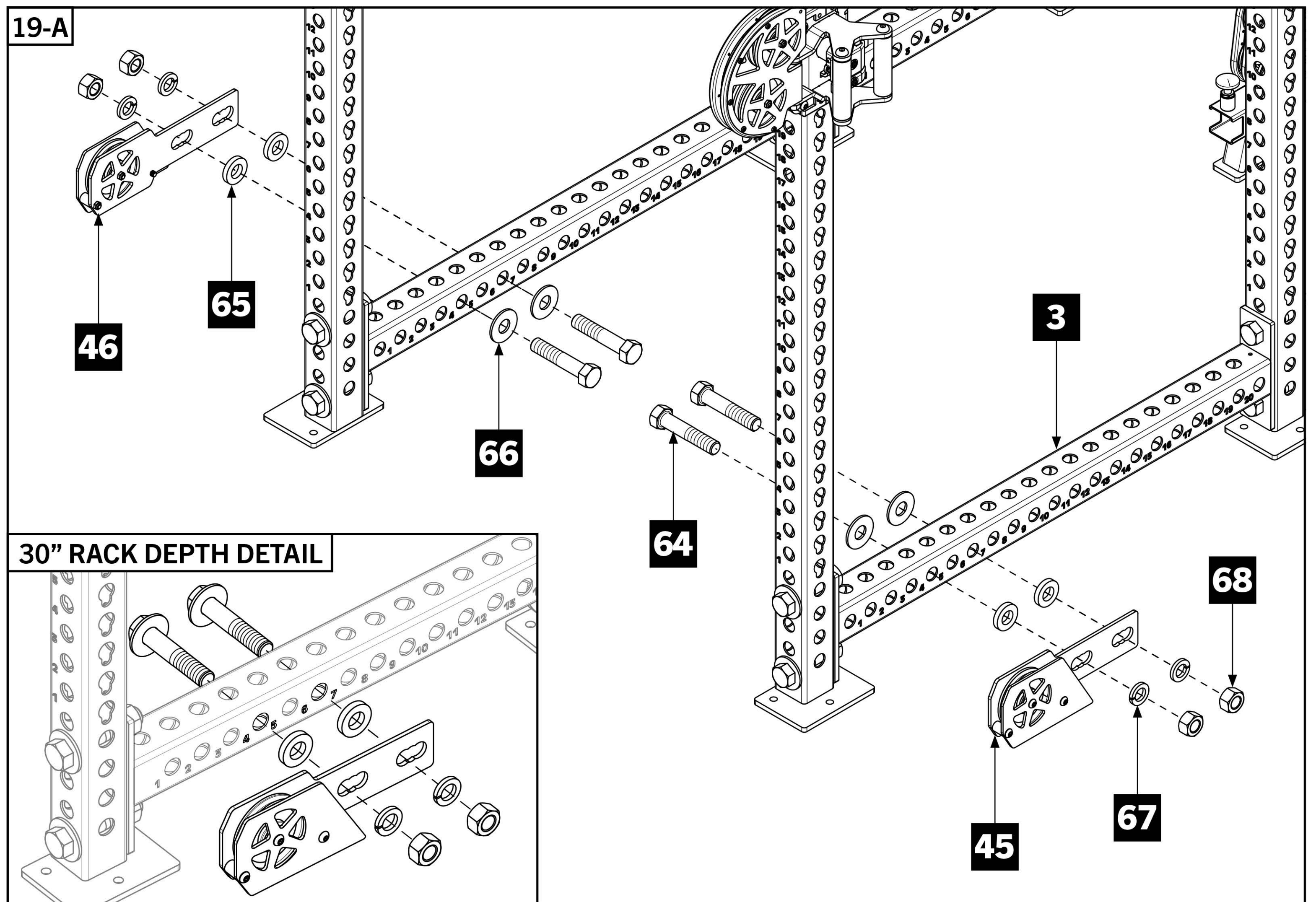
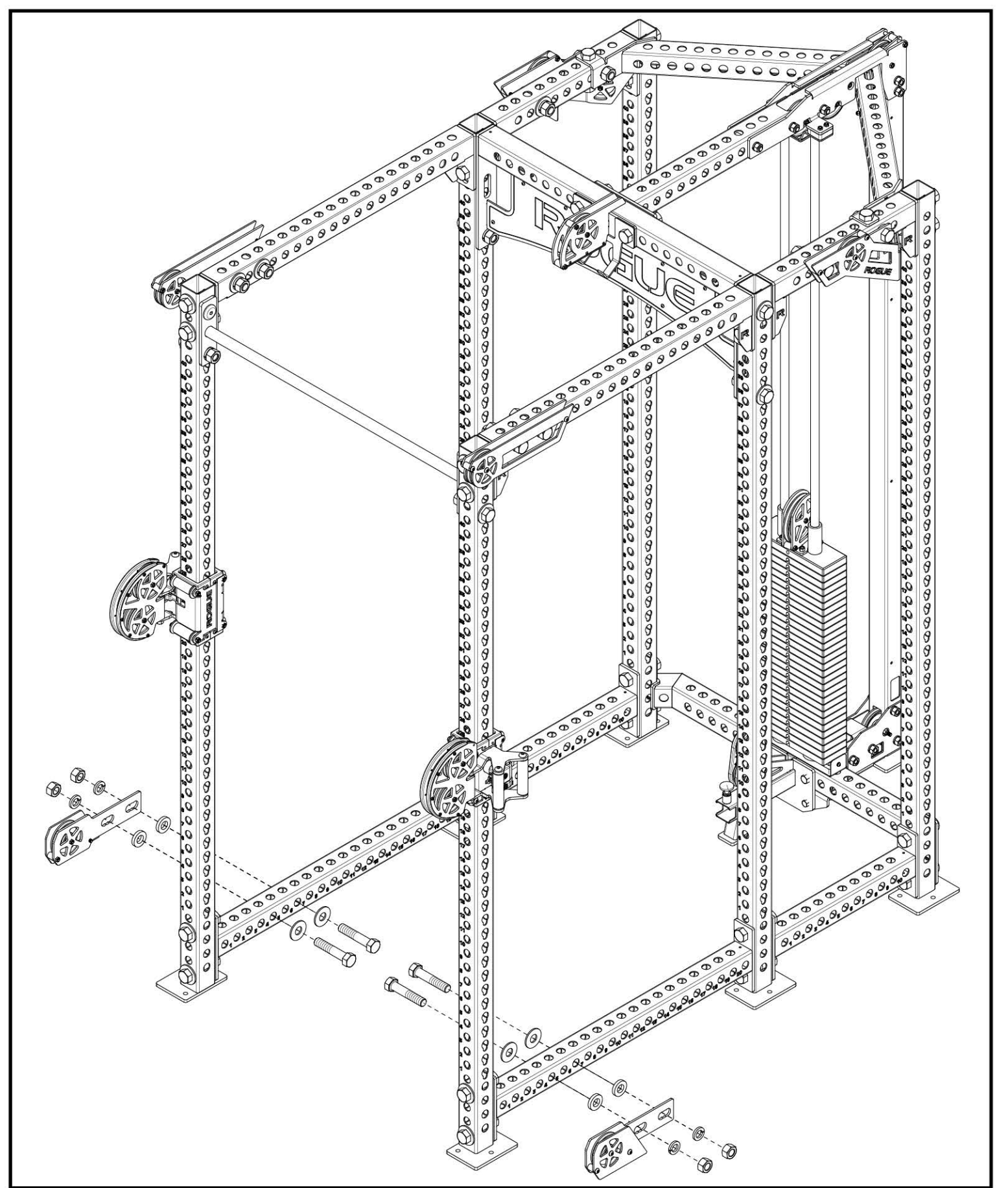

STEP 20

- Bolt Bottom Rear Side Pulley Assembly - RH [47] and -LH [48] to the 24" Rear Low Crossmembers using 1" x 5" Hex Bolts [64], 1" x 3/8" Pulley Bracket Spacers [65], 1" Flat Washers [66], 1" Lock Washers [67], and 1" Hex Nuts [68] as shown.

Note:

- Hardware is assembled through the 3rd and 9th holes on 24" Rear Low Crossmembers [5] with the bolt heads oriented inside of rack as shown.

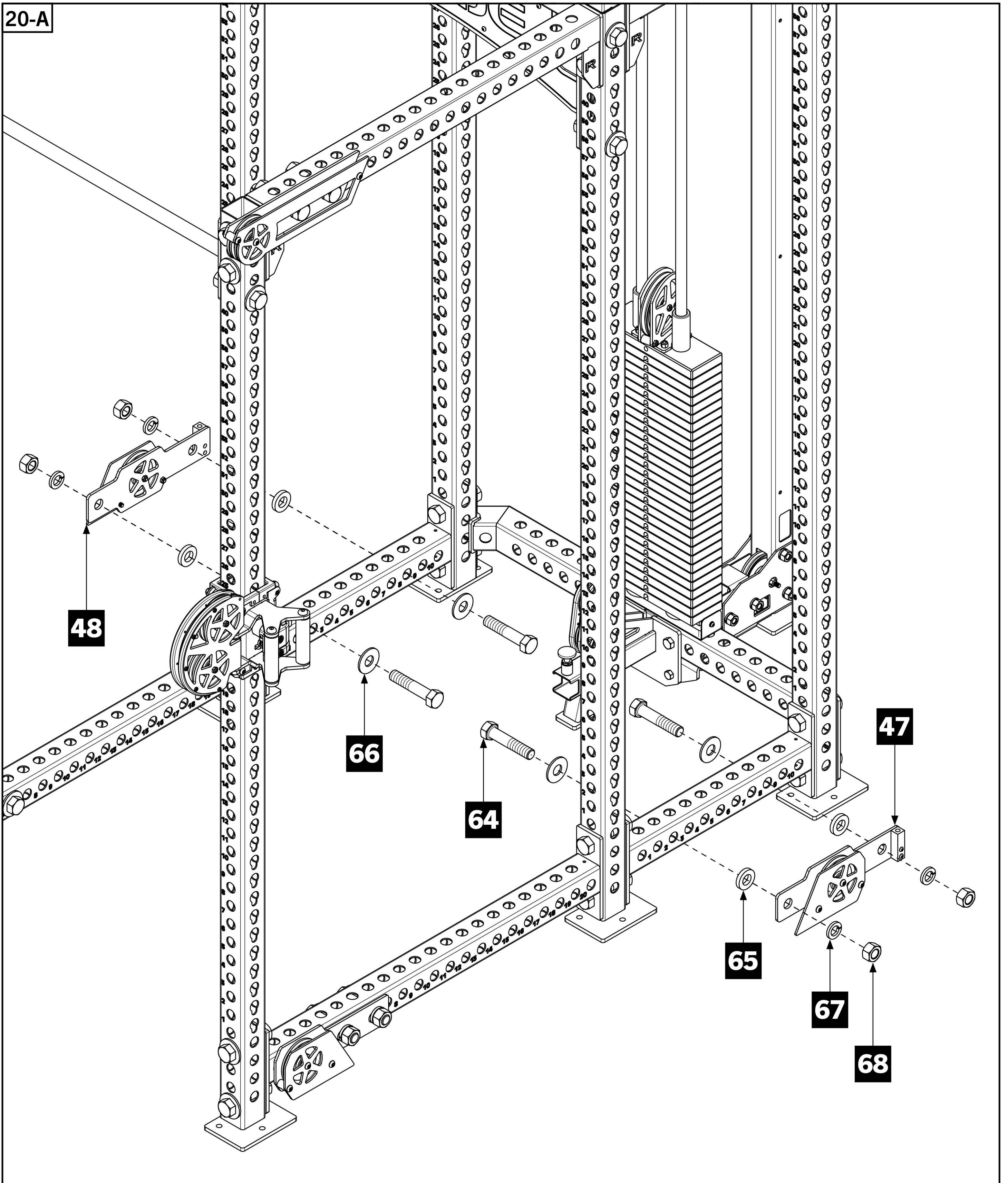
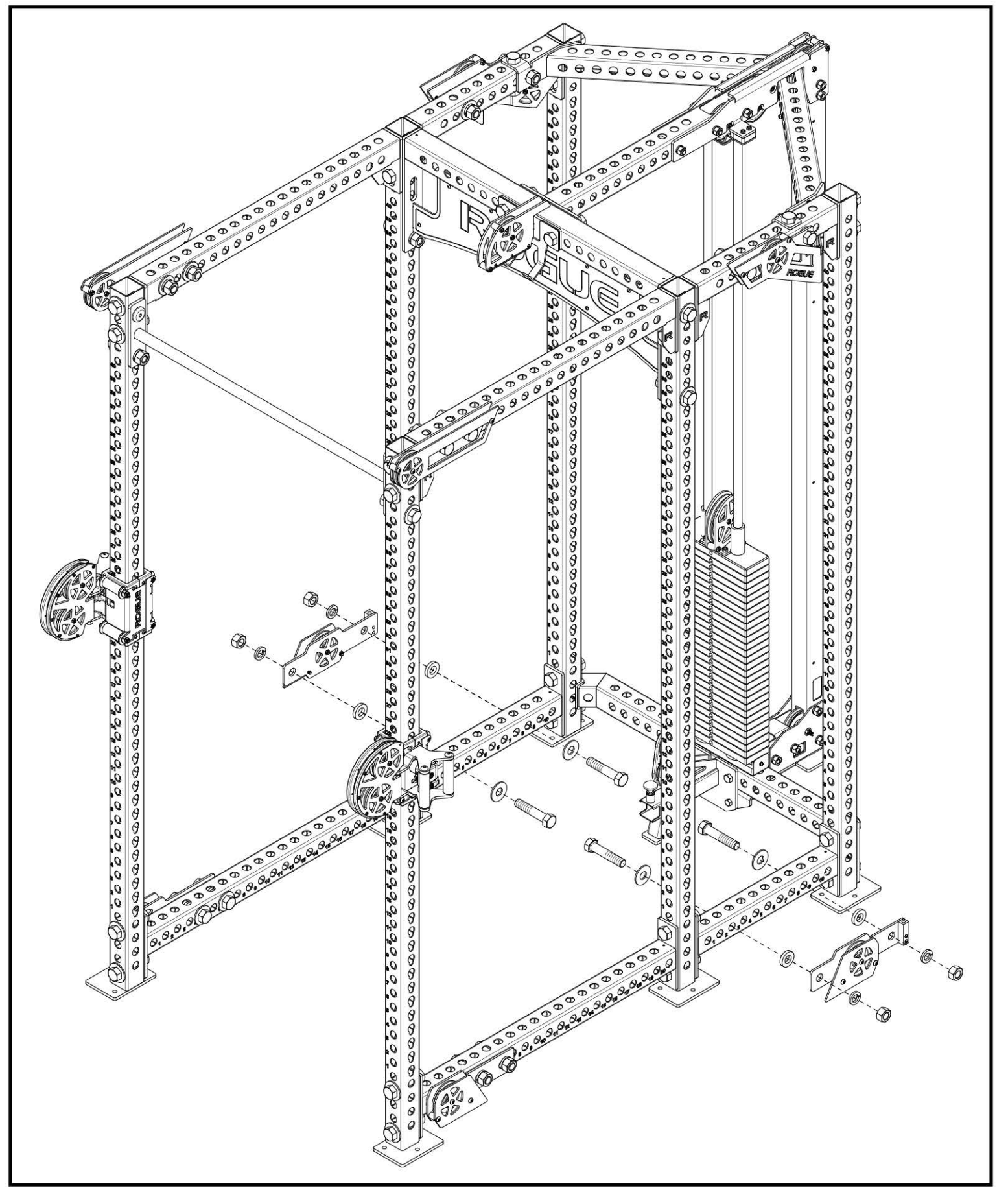

STEP 21

Note:

- Completely unwind and straighten out Trolley/Trolley Cable [53] to remove any twists/kinks prior to installation.
- The blue arrows shown in **STEP 21** through **STEP 26** indicate directions for assembling the Trolley/Trolley Cable and correspond with the blue tag on the Ball End of cable.
- Feed the Ball End of Trolley/Trolley Cable [53] between the two pulleys inside Swivel Trolley RH [19] and continue upward.
- Feed the cable around pulley inside the Top Front Side Pulley Assembly - RH [41] and continue toward the back of the rack.
- Continue around the first pulley on Top Rear Side Pulley Assembly - RH [43] and then downward.

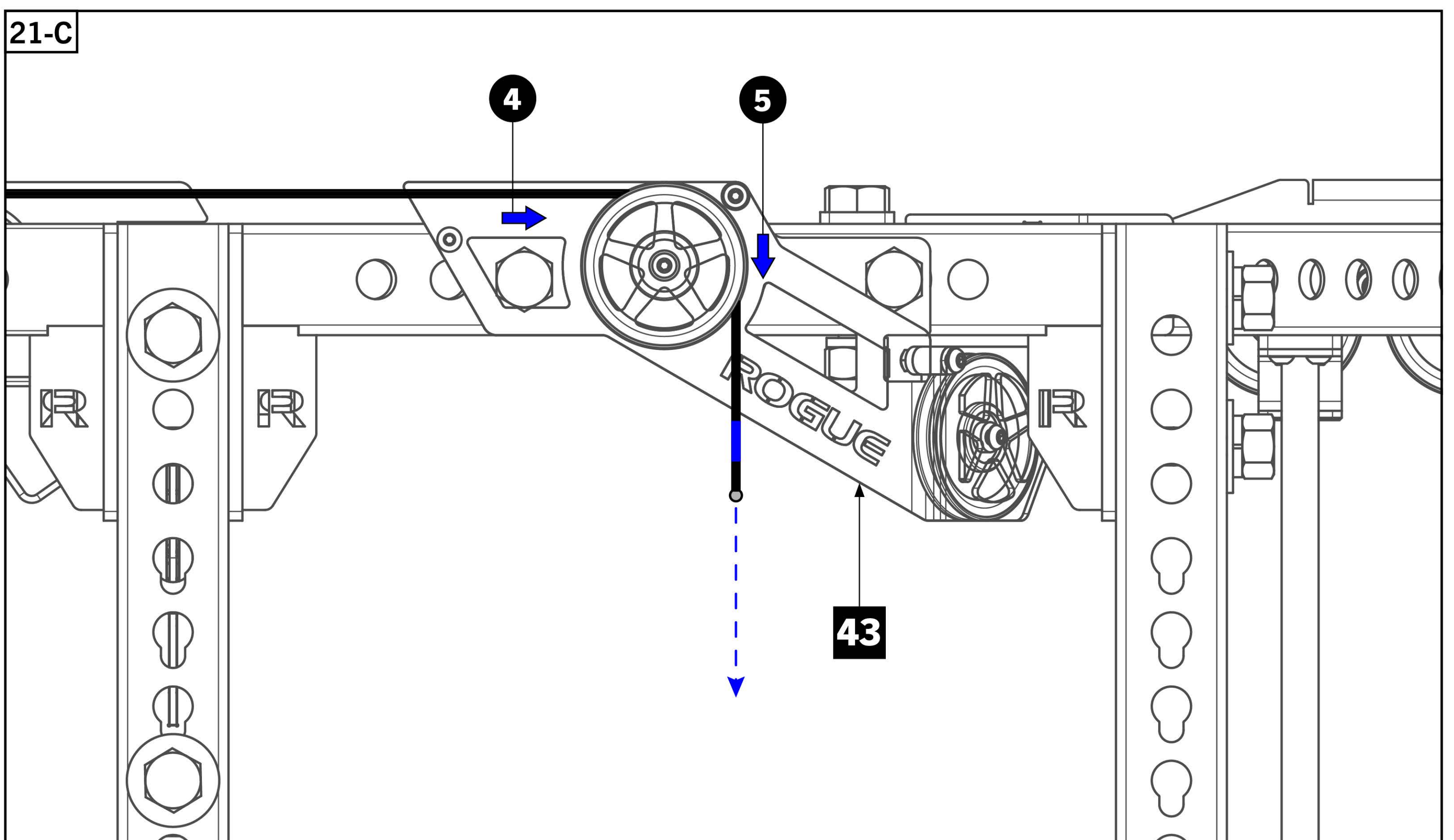
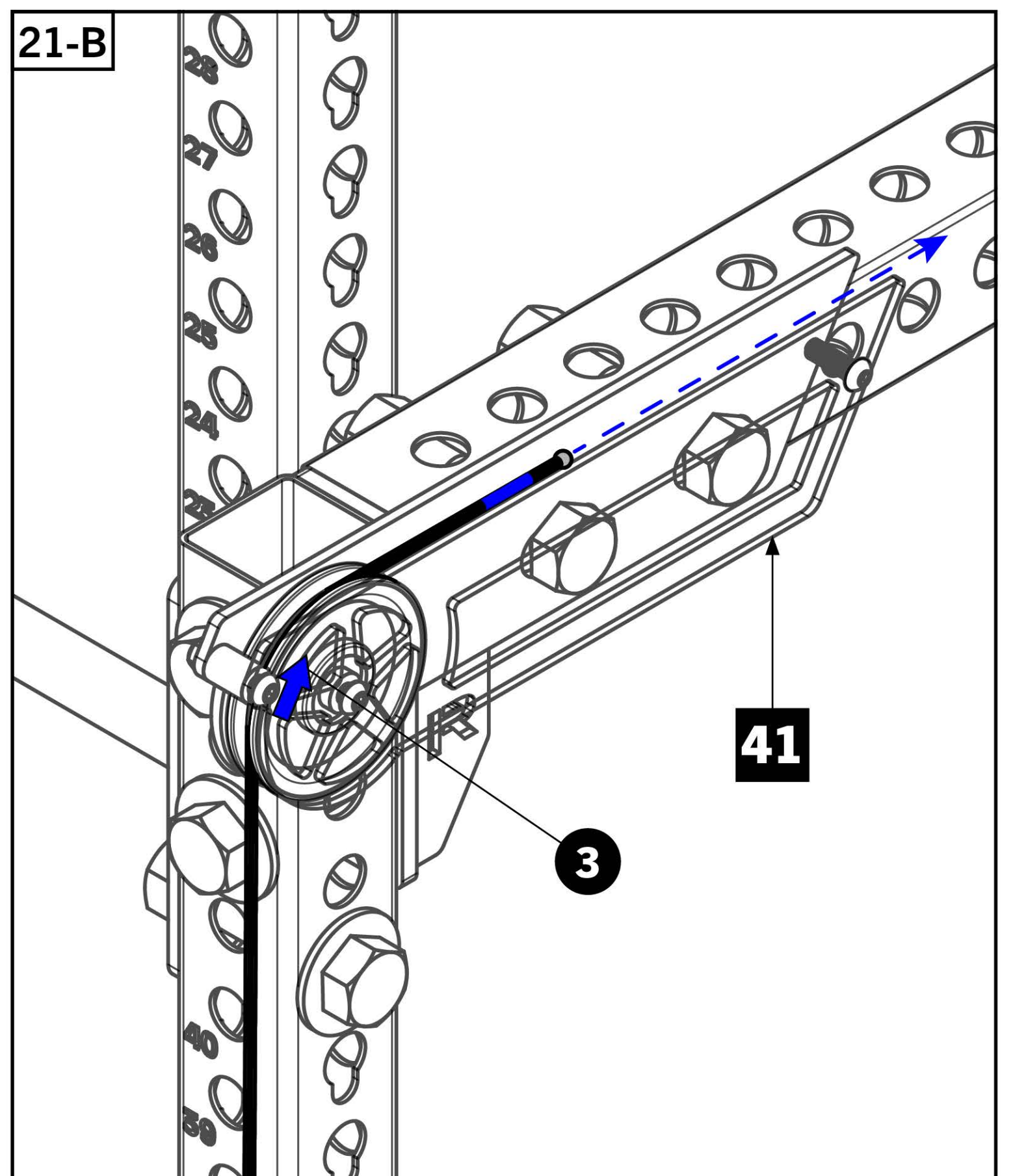
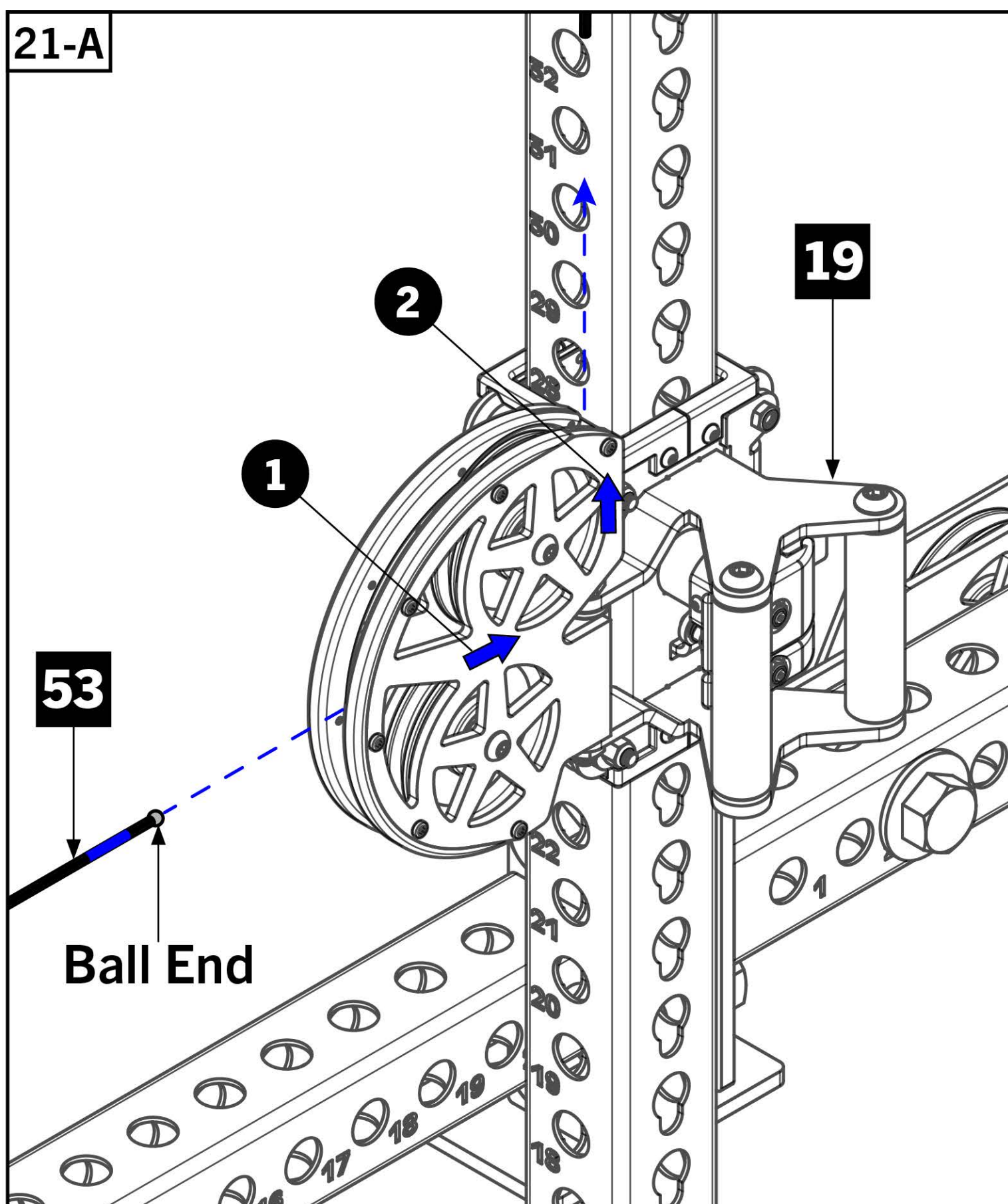
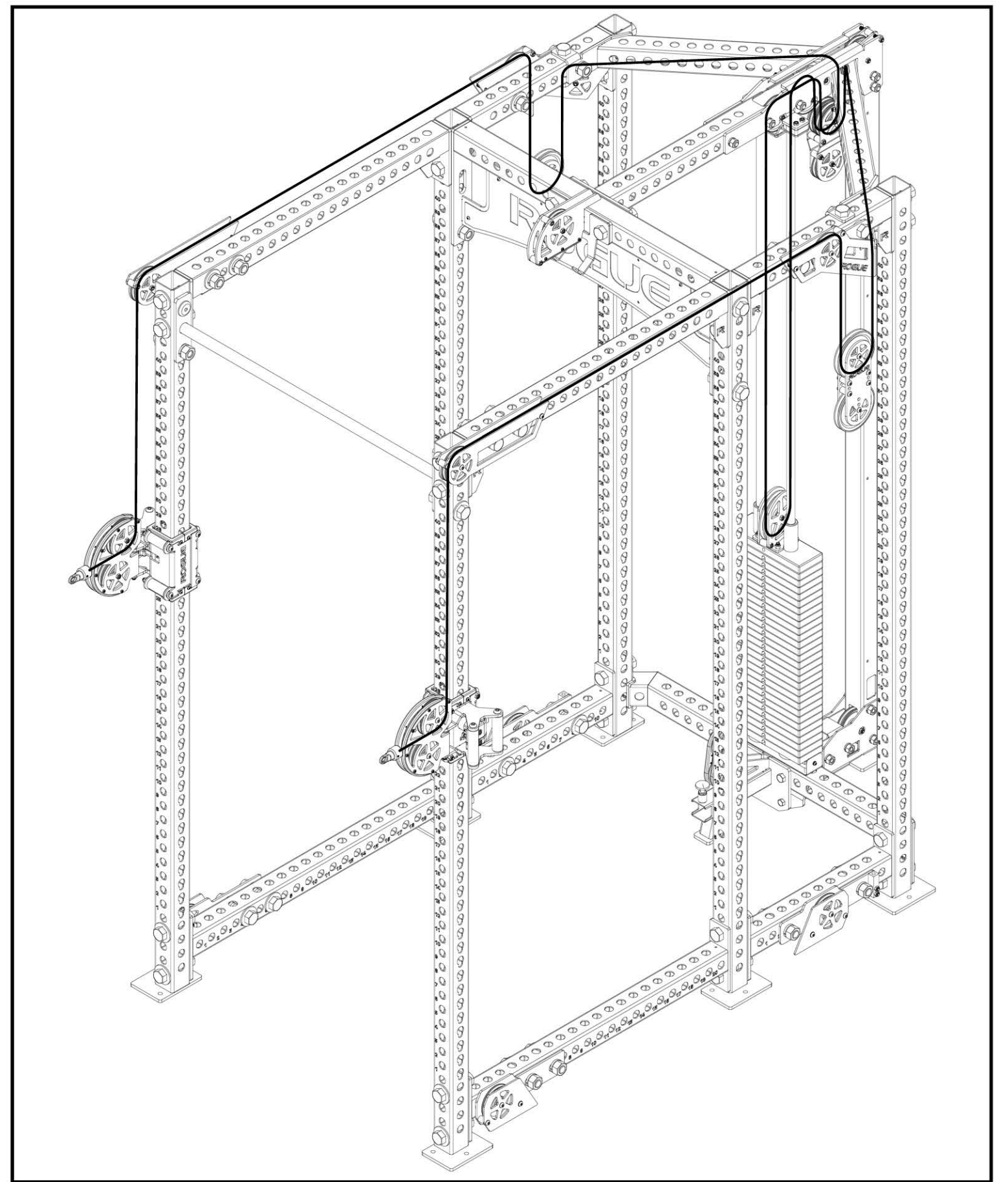

STEP 22

- Hold one Side Peanut Pulley [50] in the air, ensuring the arrow stickers correspond to diagram 22-A.
- Feed the cable down and around the upper pulley of Side Peanut Pulley and then back up towards the Top Rear Side Pulley Assembly - RH [43].
- Feed cable around the angled pulley shown in 22-B and continue towards the Rear 3X3 Upright.

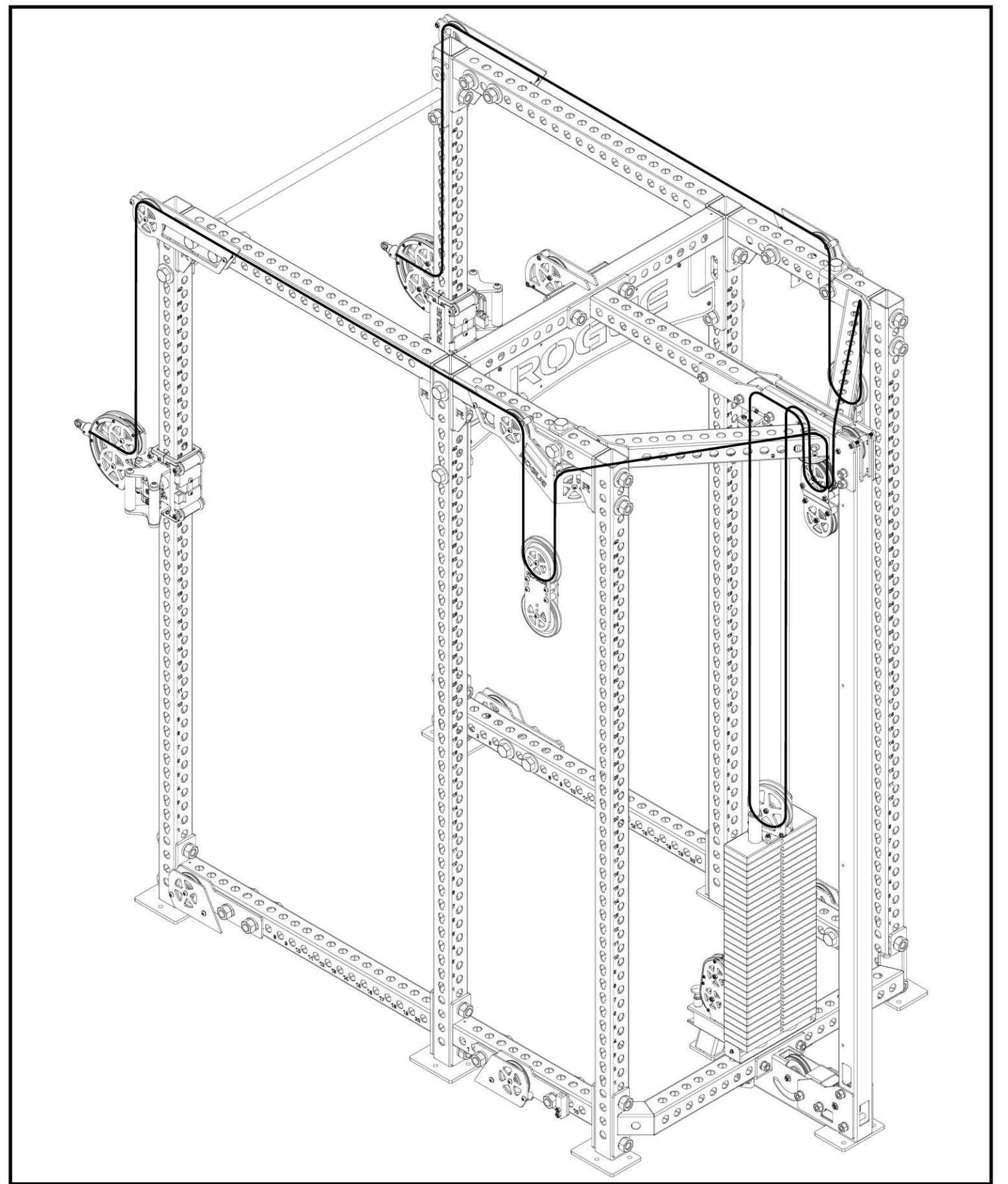

22-A

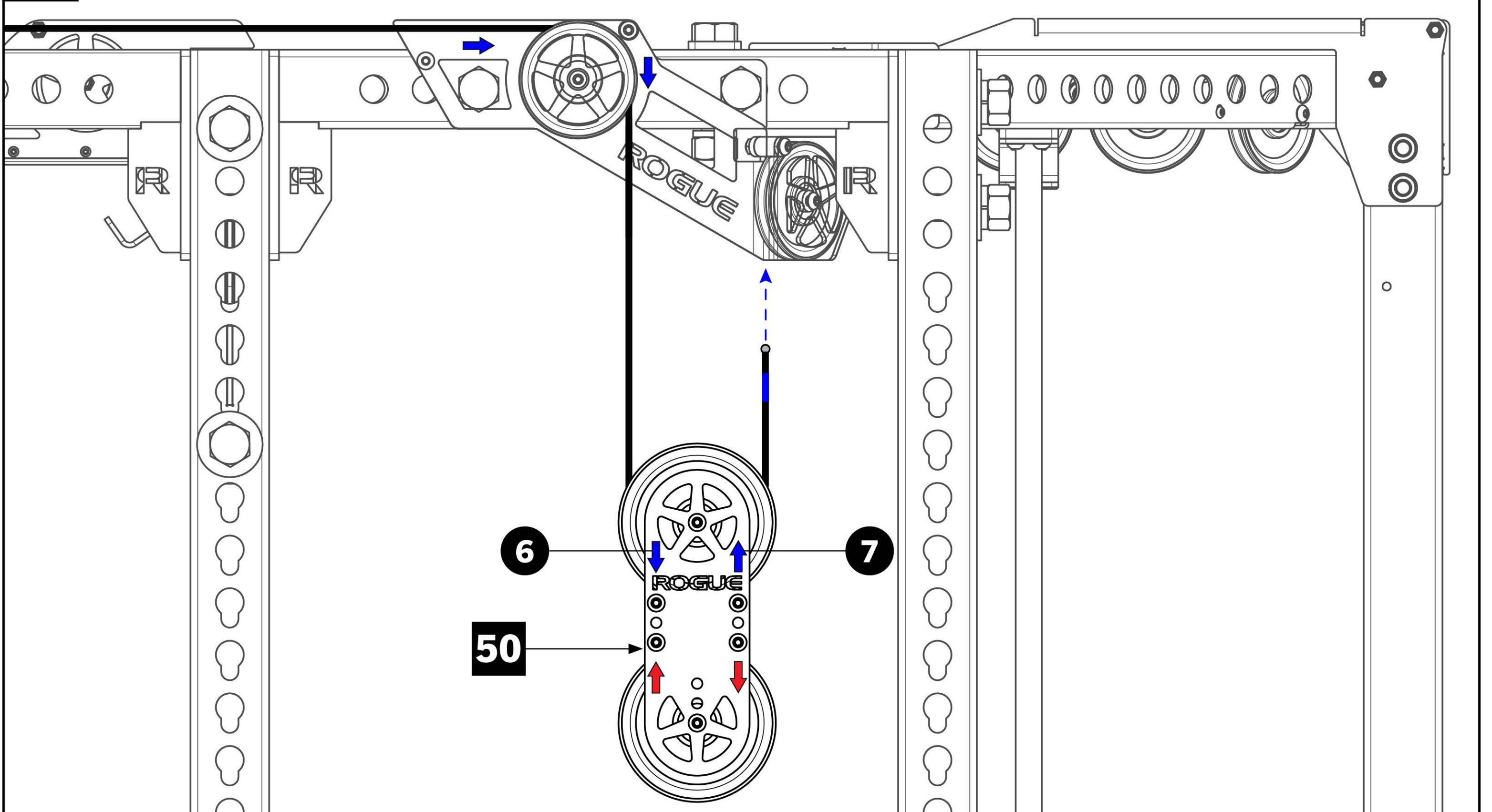

22-B

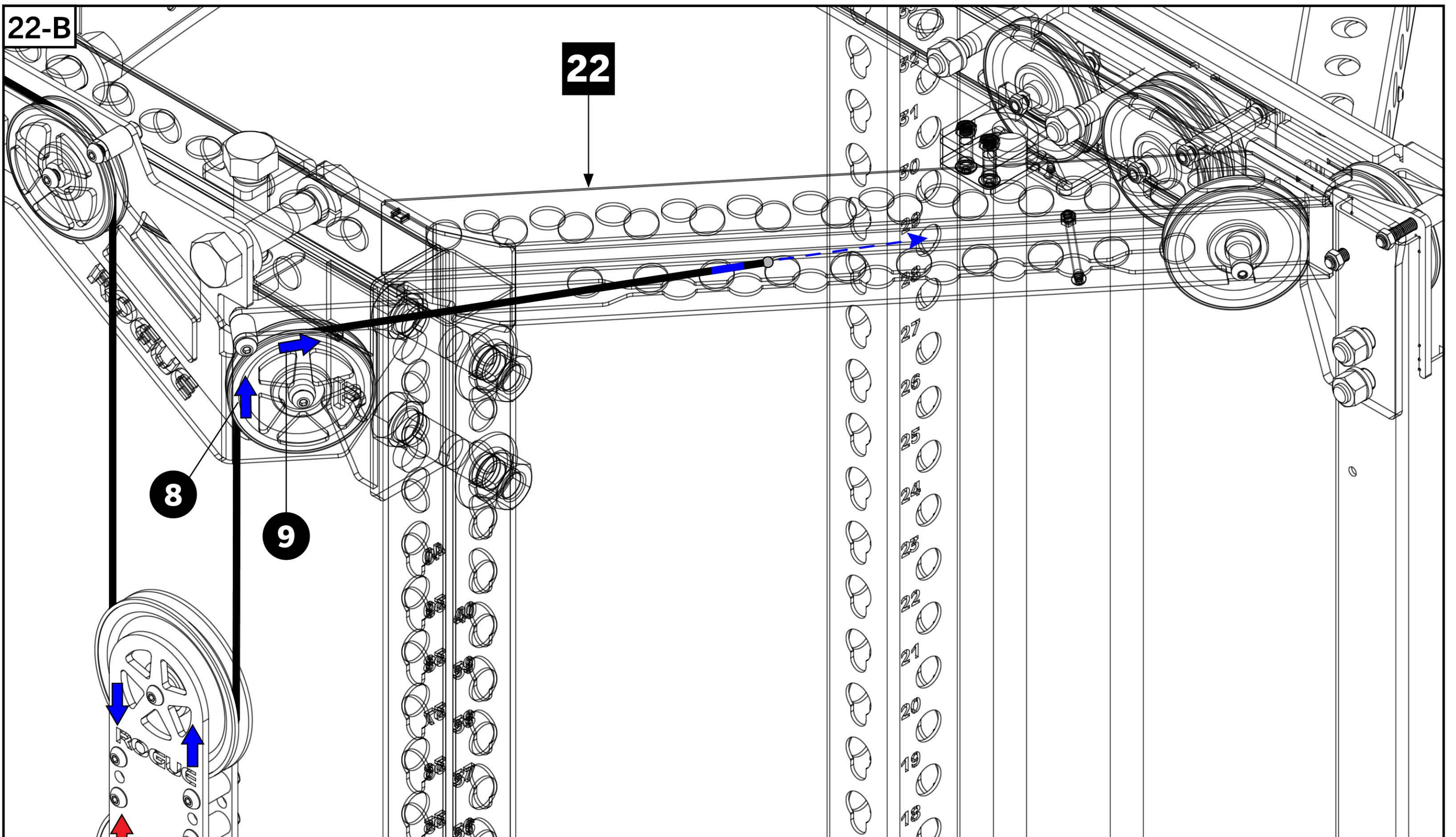

STEP 23

- Feed cable around the next angled pulley at rear of the Top Rear Angle Crossmember - RH [22] as shown.
- Hold the Rear Peanut Pulley [49] underneath cable, ensuring the arrow stickers correspond to diagram 23-B.
- Feed cable around the upper RH offset pulley in the Peanut, and then back up and around the next two pulleys shown in 23-C.

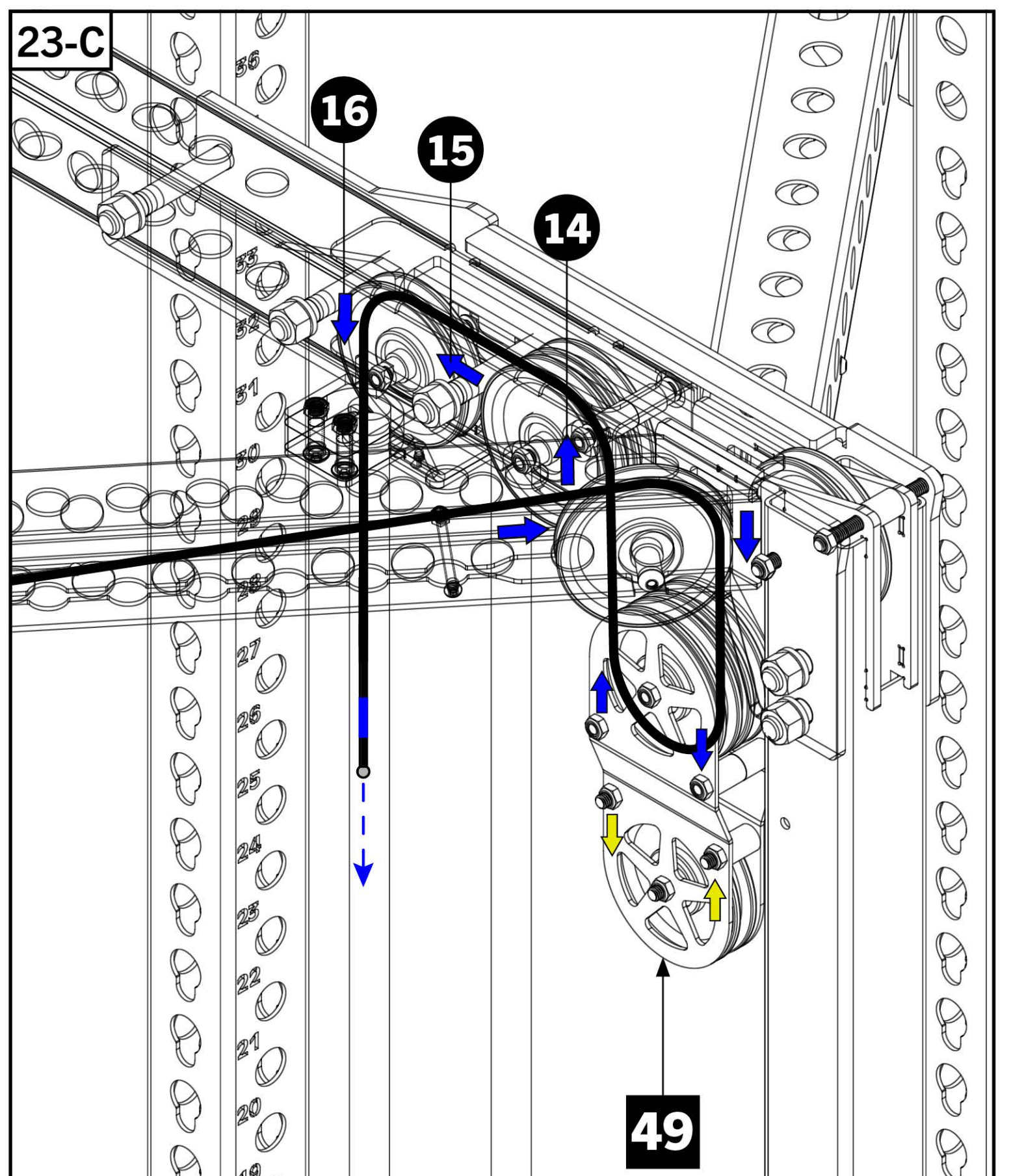
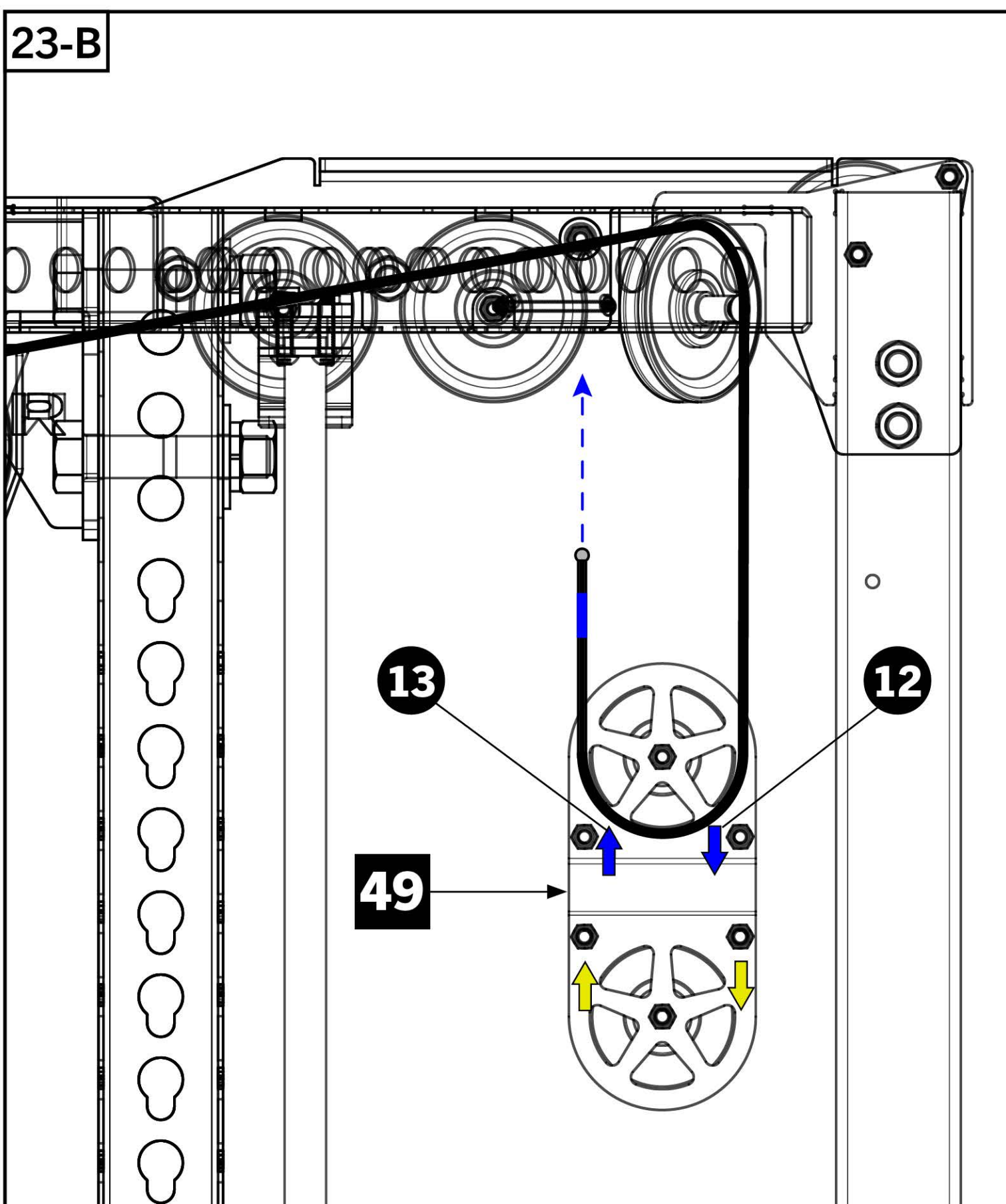
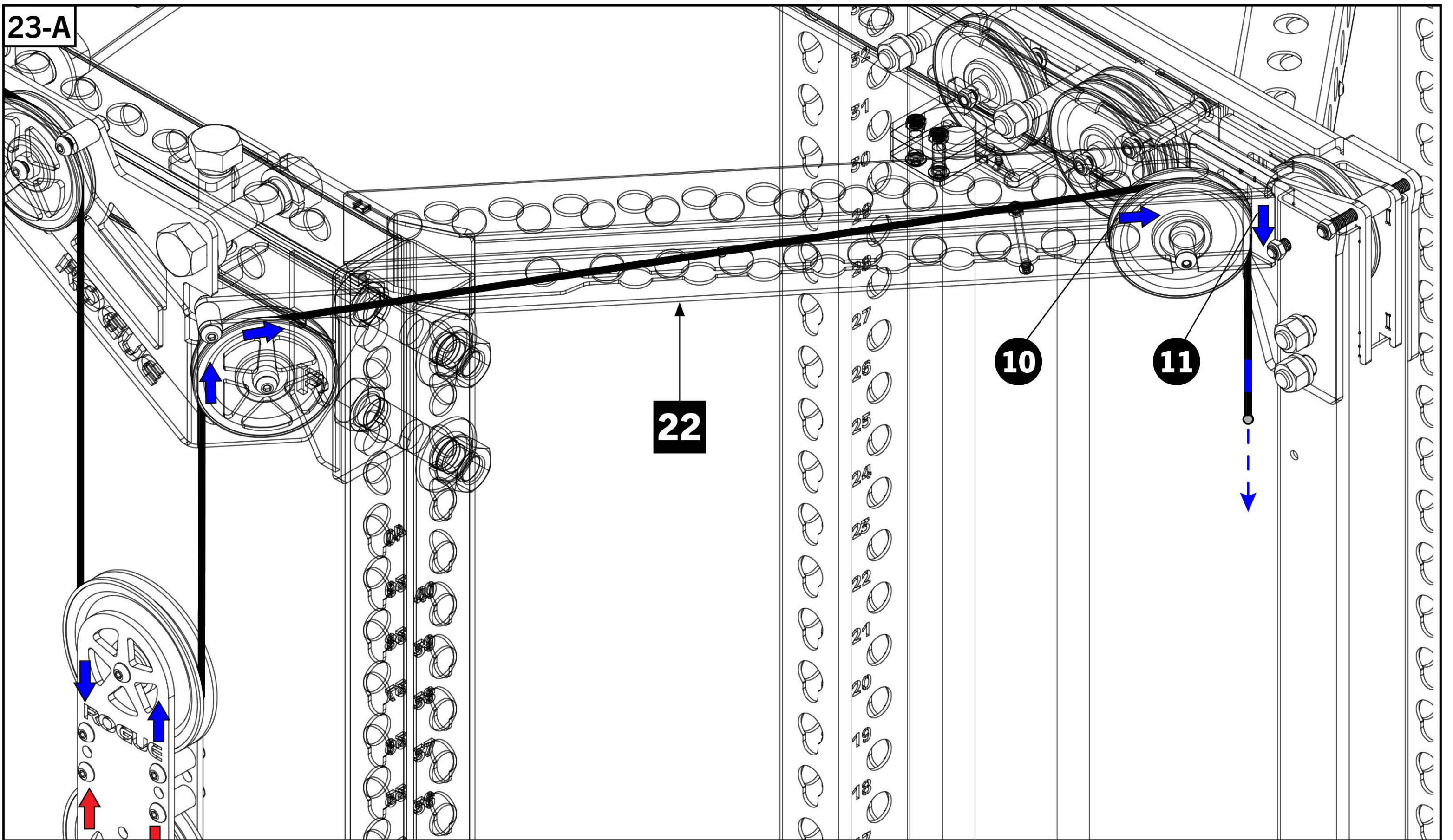
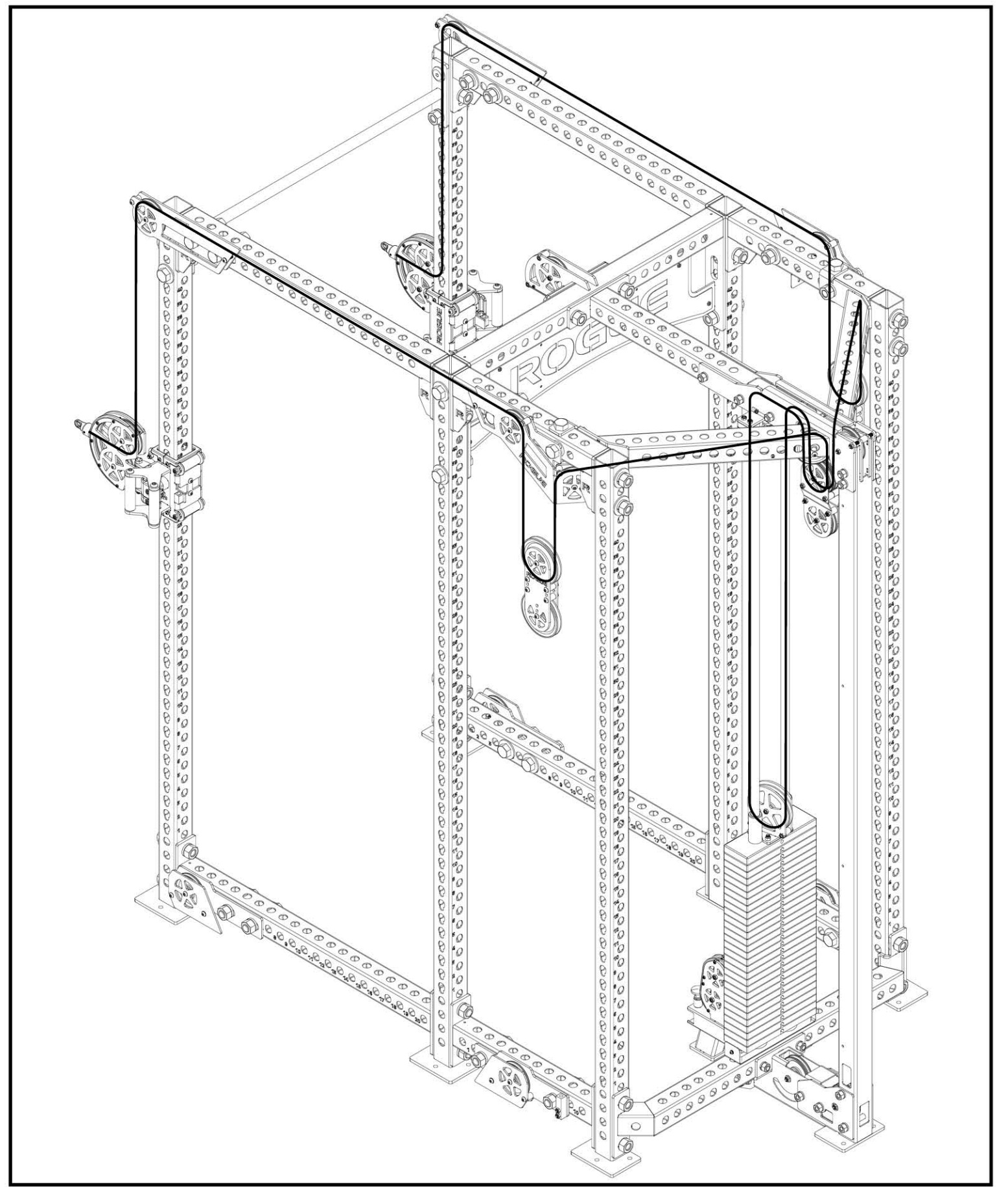

STEP 24

- Continuing down towards the Weight Stack, feed cable around the large 6.5" Pulley located on top of the Weight Stack Stem. **Tip:** a flathead screwdriver may be used to help guide cable through turn 18.
- Feed cable back up to the Top Center Crossmember, feeding around the pulley shown in **24-B** and then immediately back down towards the Rear Peanut Pulley [49].
- Continue around the other Top Pulley on the peanut and then back up and around the pulley shown in the Rear Angled Crossmember - LH [23].
- Continue around the next angled pulley located in the Top Rear Side Pulley Assembly - LH [44] and then downward.

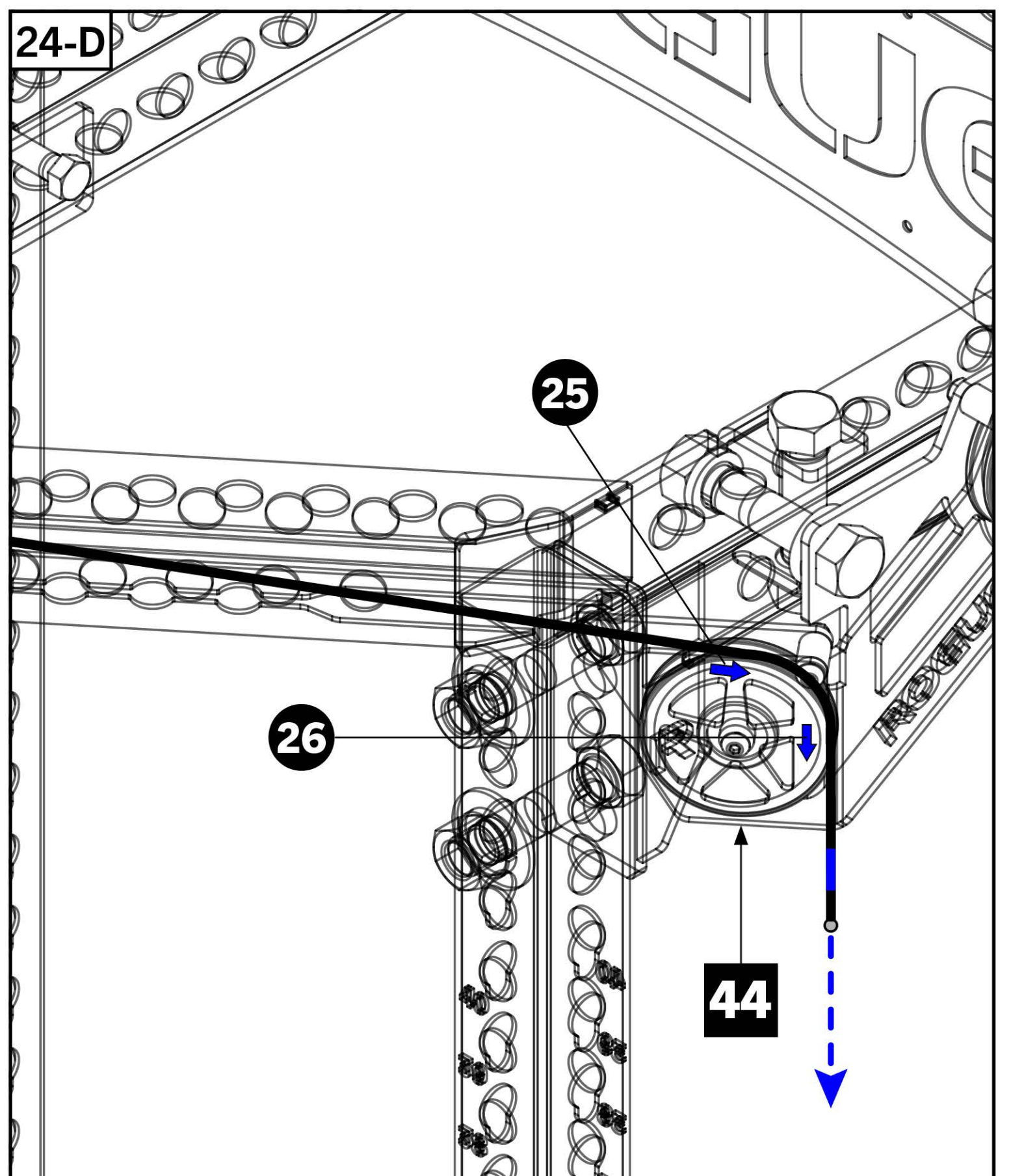
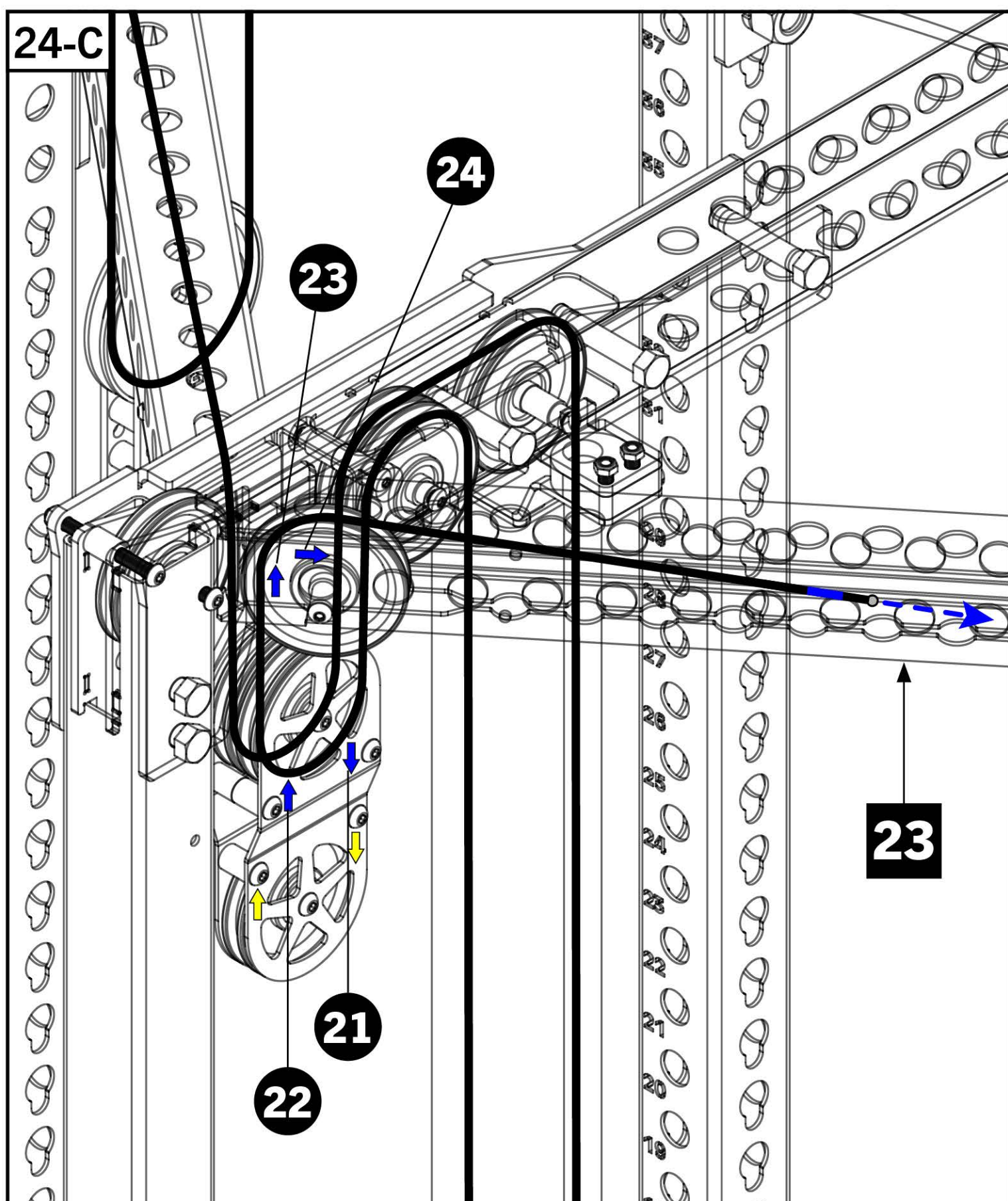
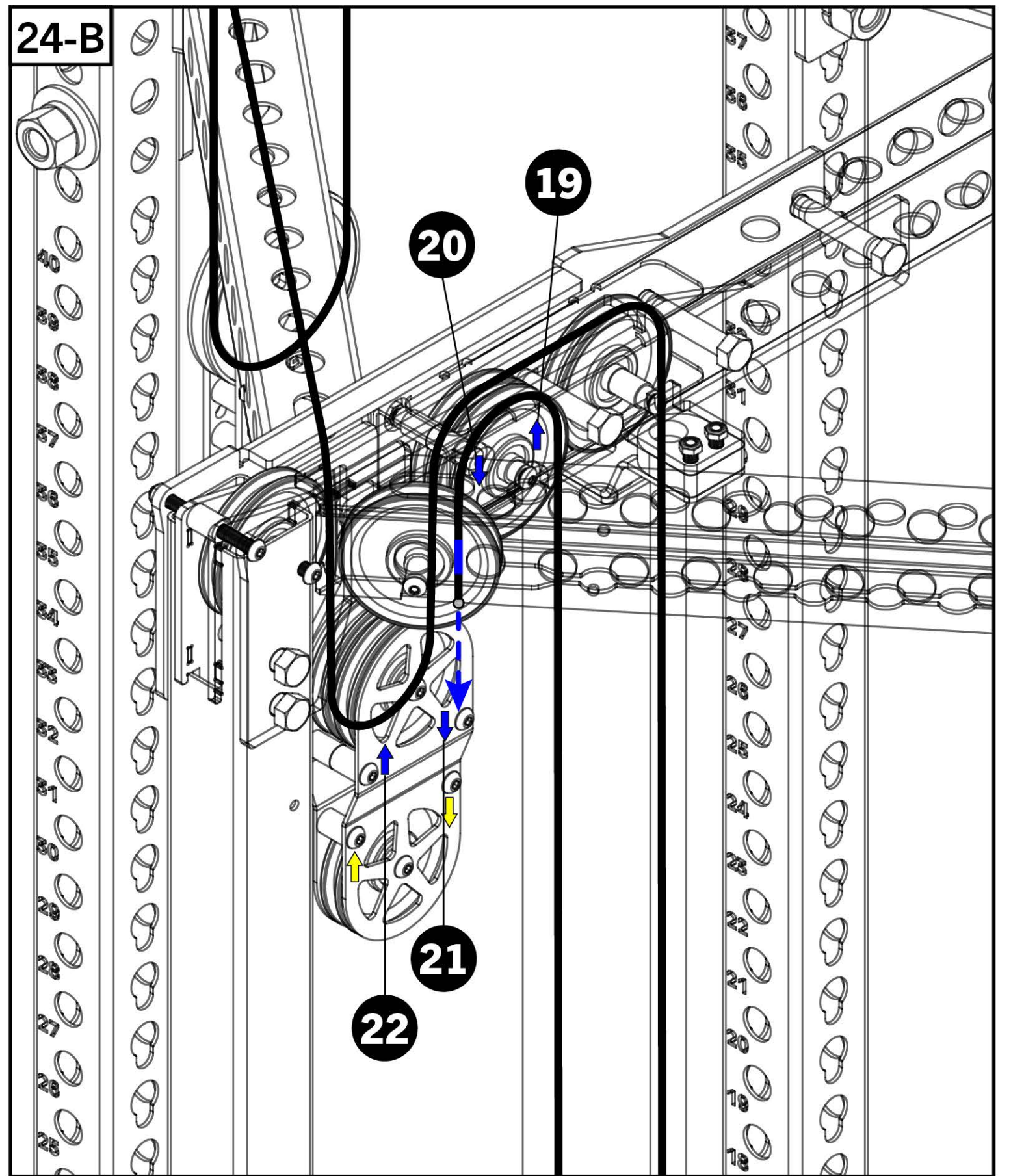
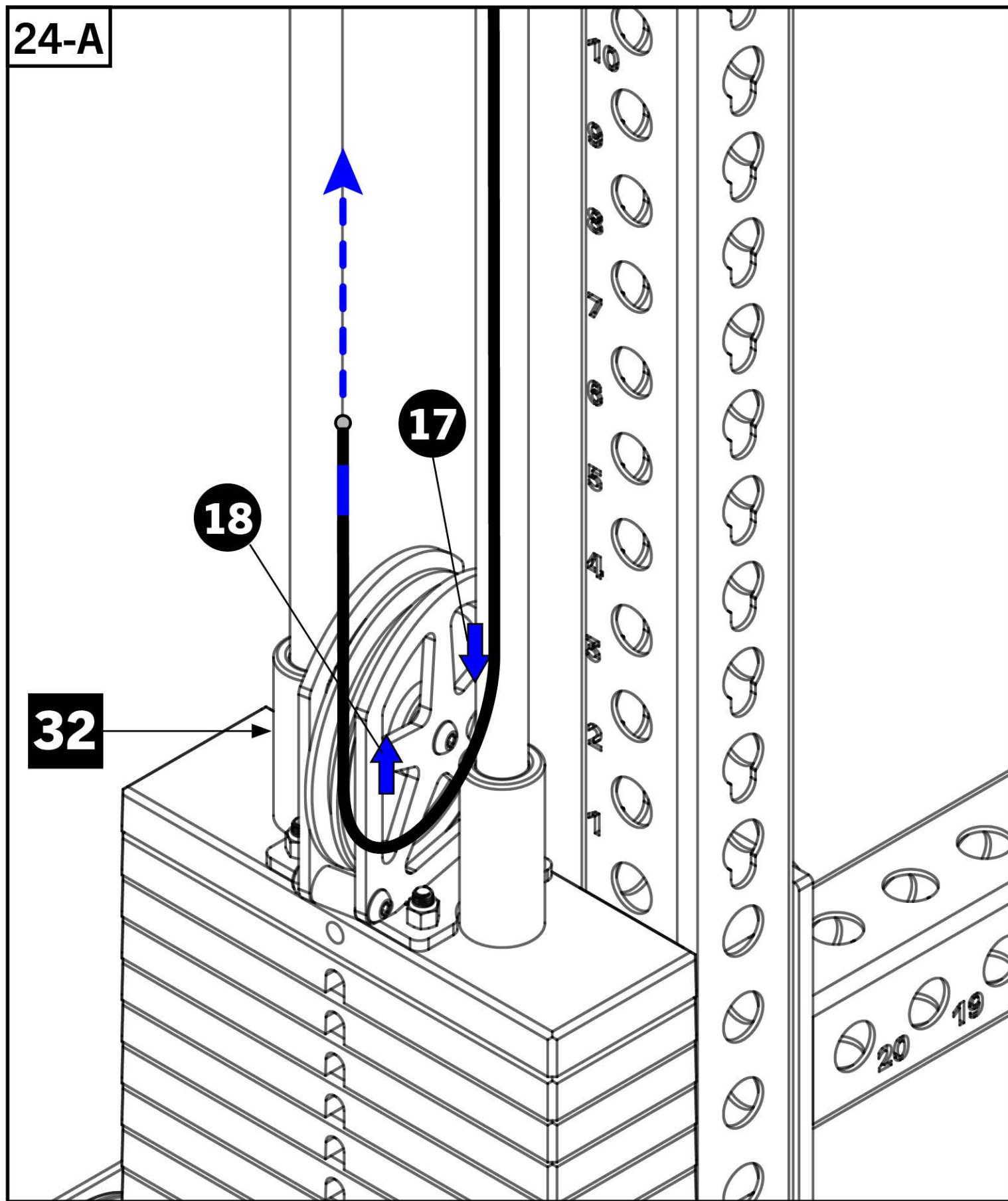
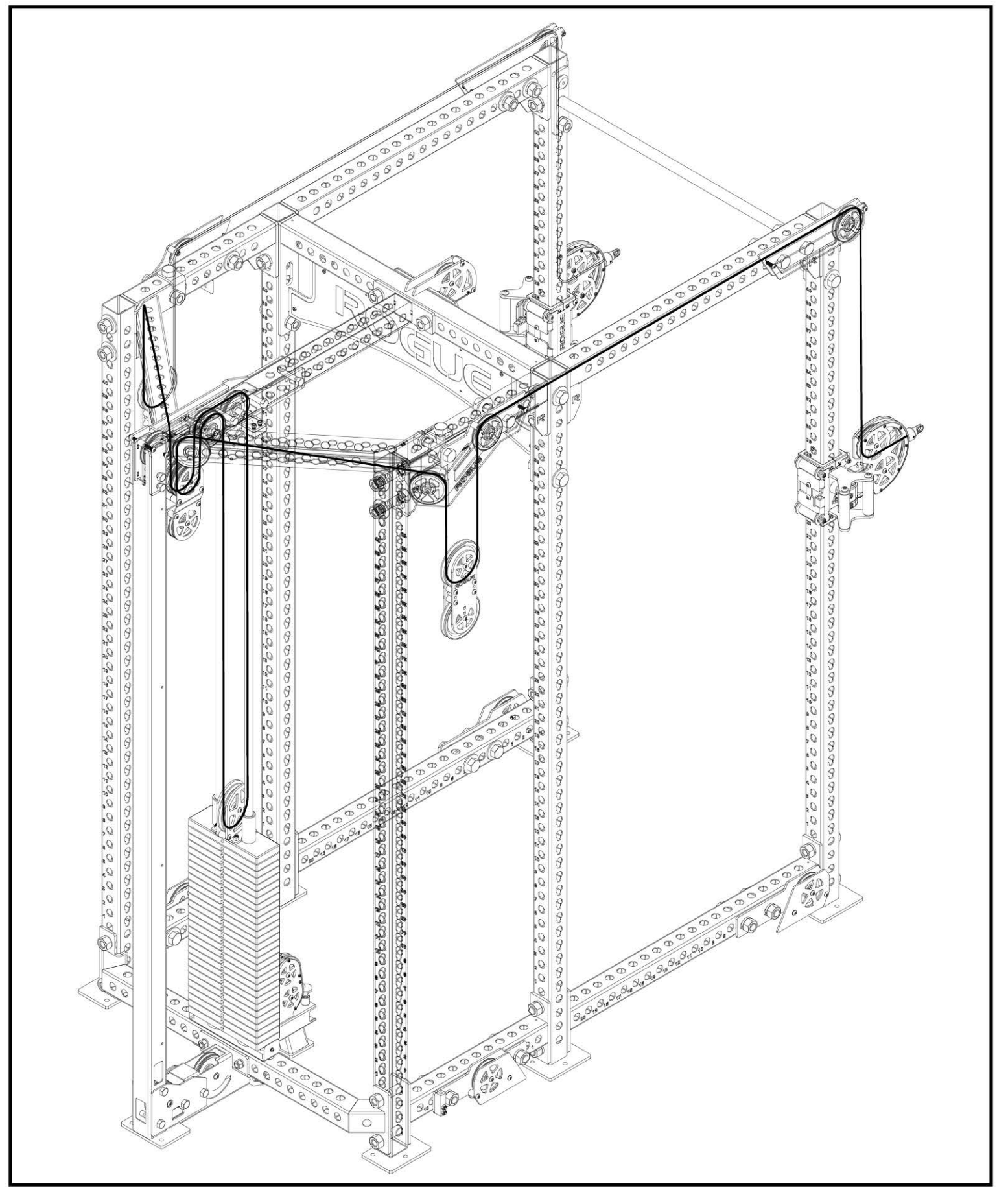

STEP 25

- Hold the remaining Side Peanut Pulley [50] in the air, ensuring the arrows correspond to diagram 25-A.
- Feed cable around the upper peanut pulley and then back up towards the Rear Side Pulley Assembly.
- Feed around the pulley shown in 25-B and then towards the front of the rack.
- Continue around the Top Front Side Pulley Assembly - LH [22], then down and out through the front of the Swivel Trolley LH [20].
- Pull Ball End of cable out far enough to assemble Clevis on next step.

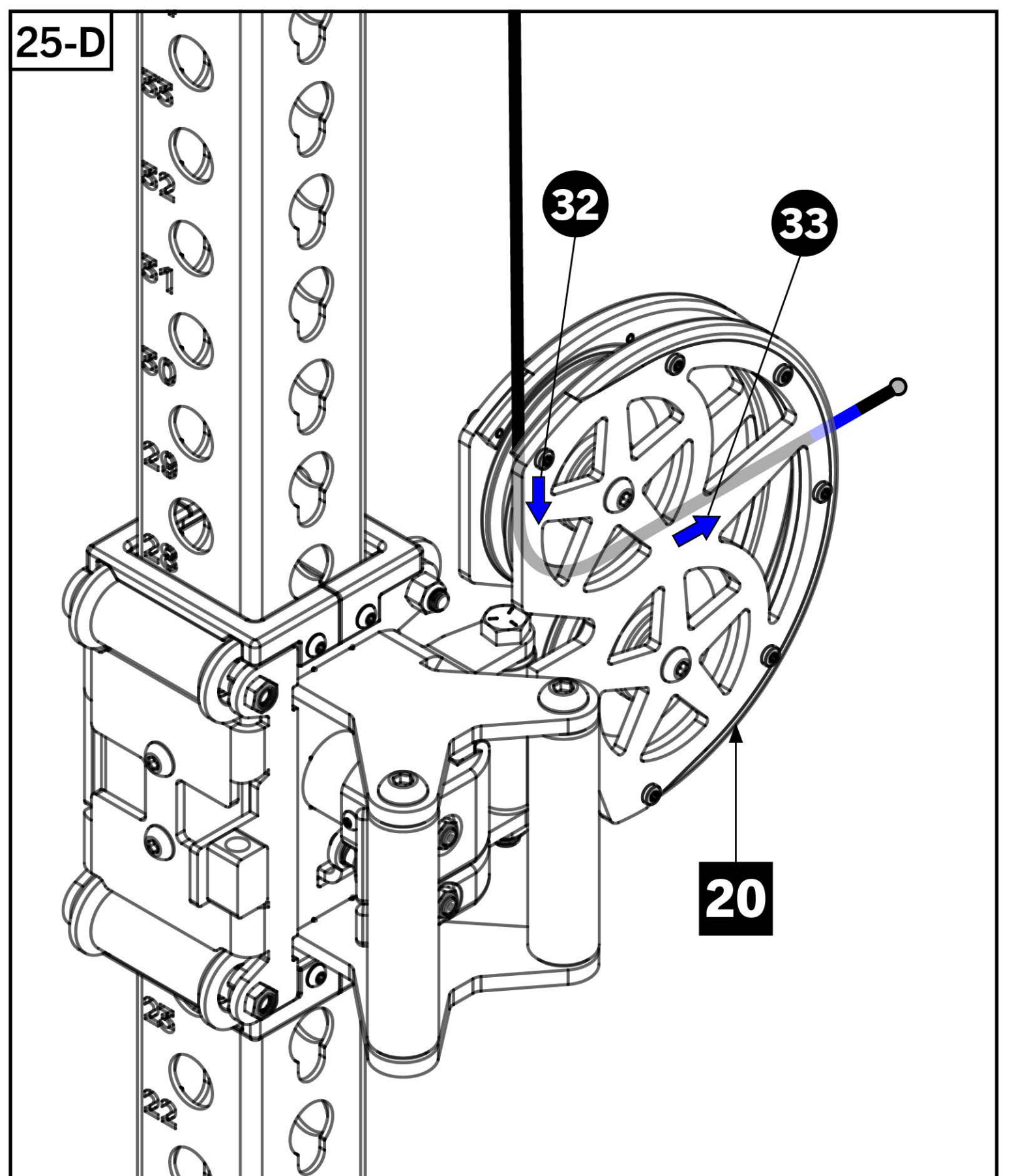
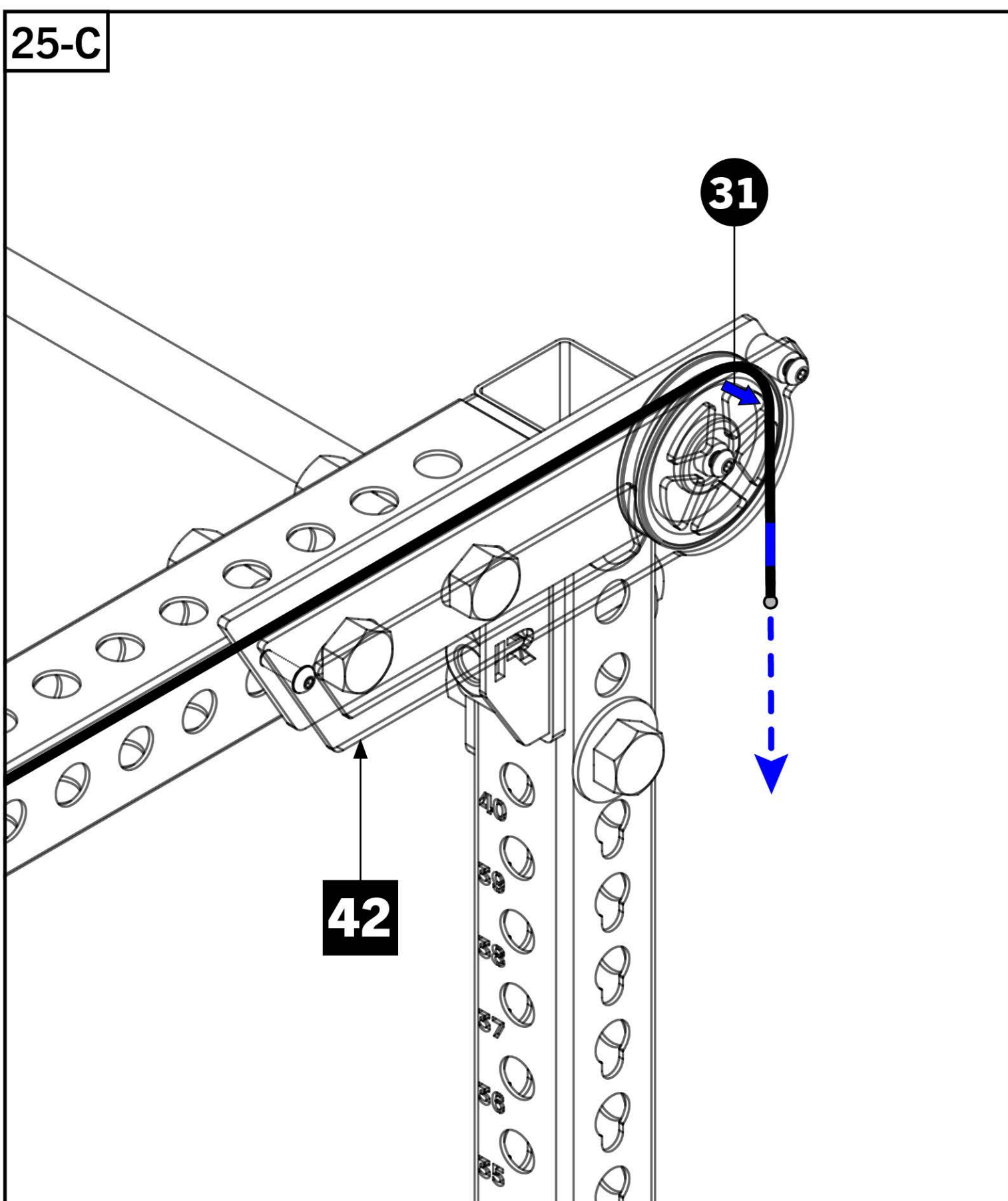
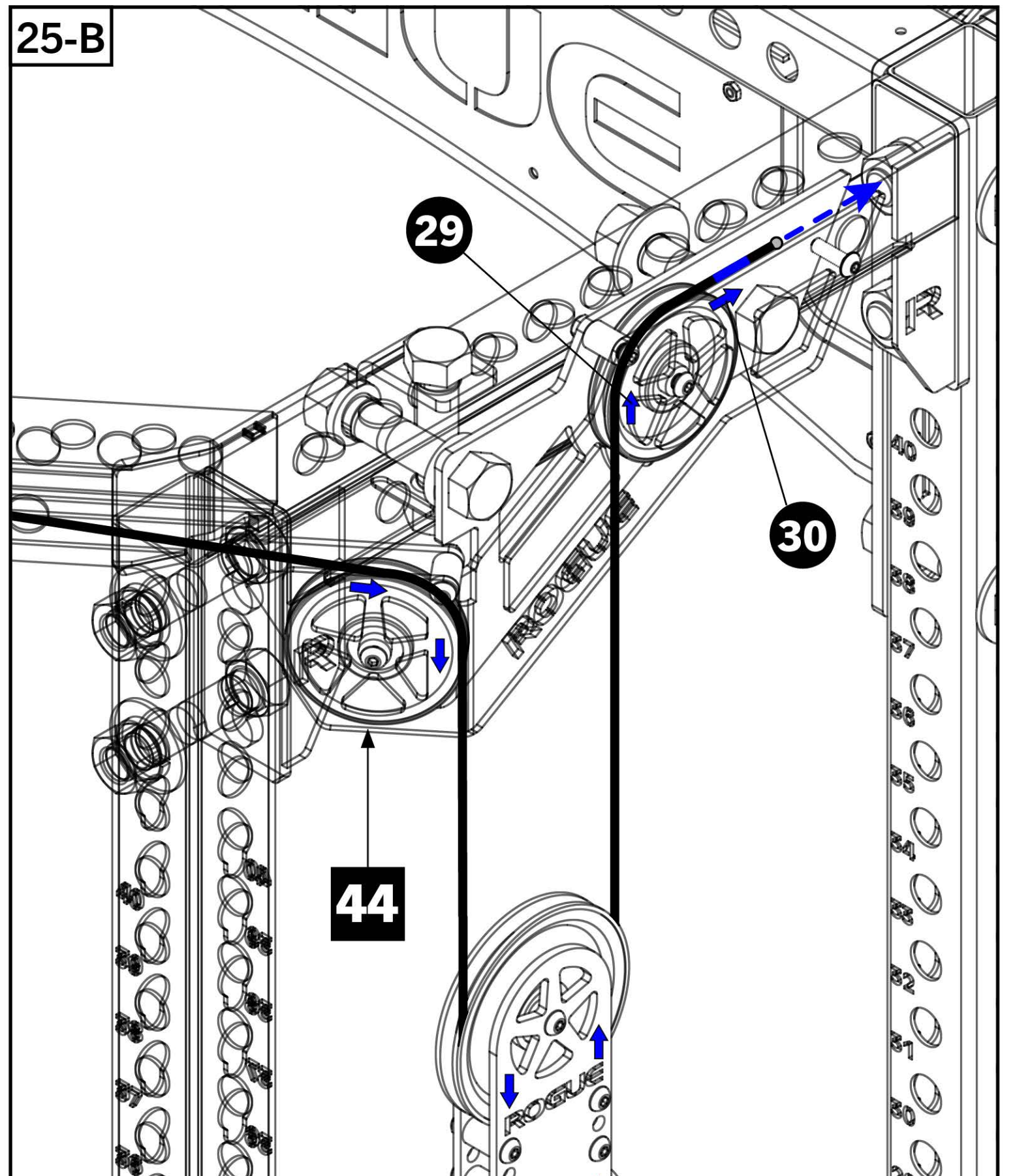
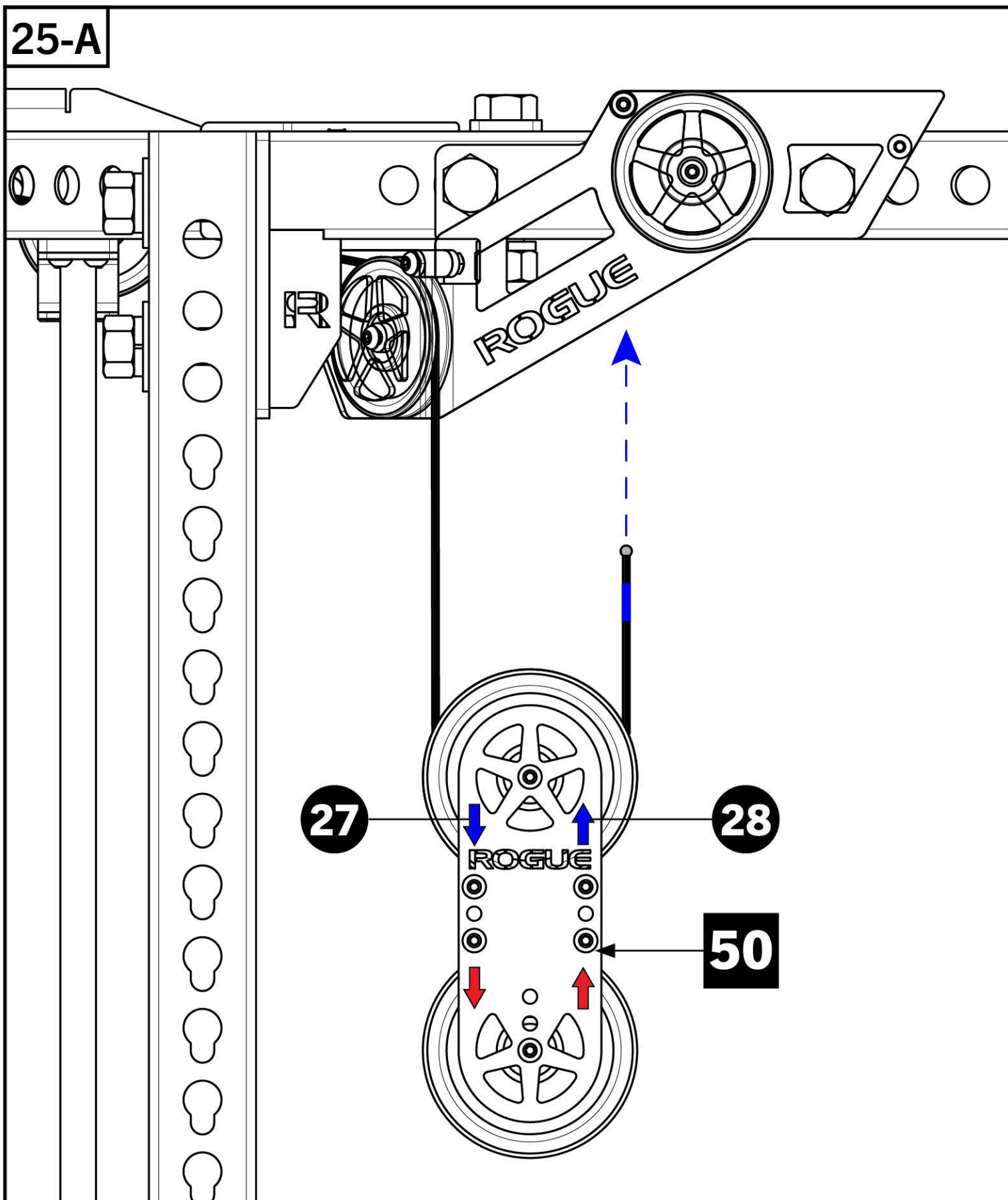
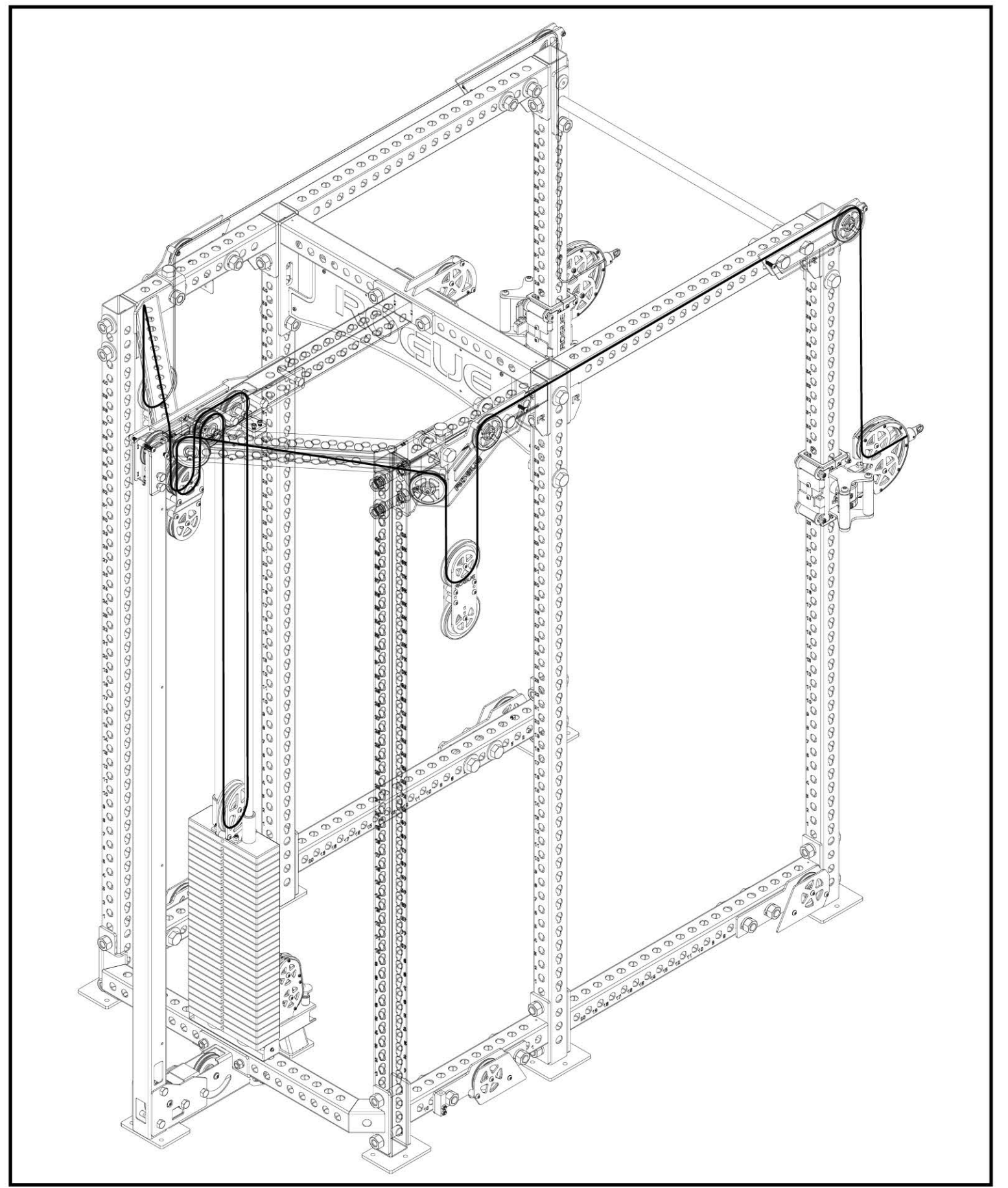

STEP 26

Tools Required:

- 3/32" Allen Key & 5/8" Wrench
- Completely disassemble the loose Clevis included with cable by unscrewing set screws and Split Threaded Insert, and remove blue tag on end of cable.
- Slide parts over the ball on cable as shown on 26-B.

- Insert Grommet into non-threaded side of Split Threaded Insert and screw Clevis End on threaded side using 5/8" Wrench.
- Slide Plastic Stop forward and align outer holes with threaded holes on Clevis End and re-insert Set Screws. Fully tighten Set Screws.

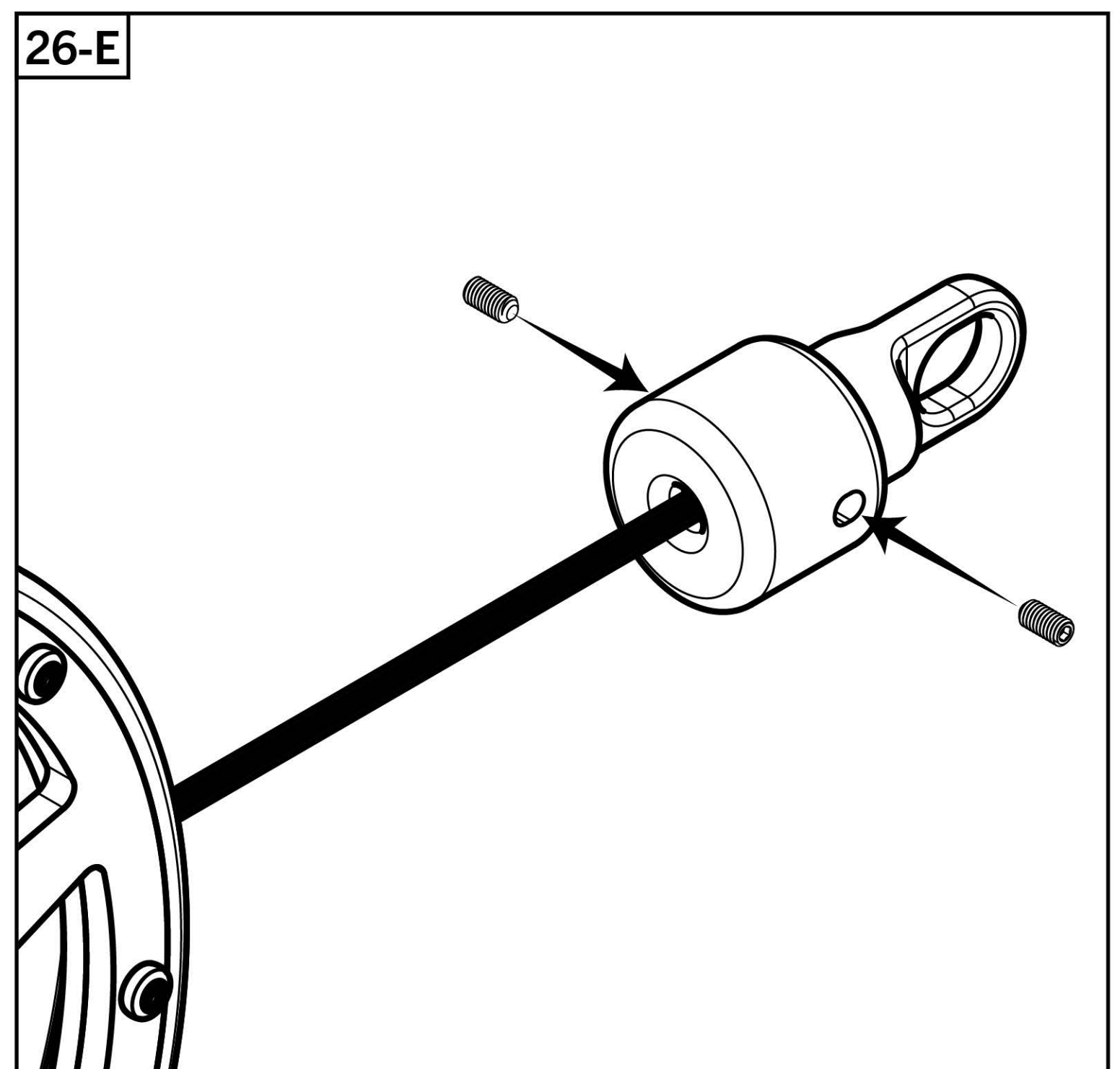
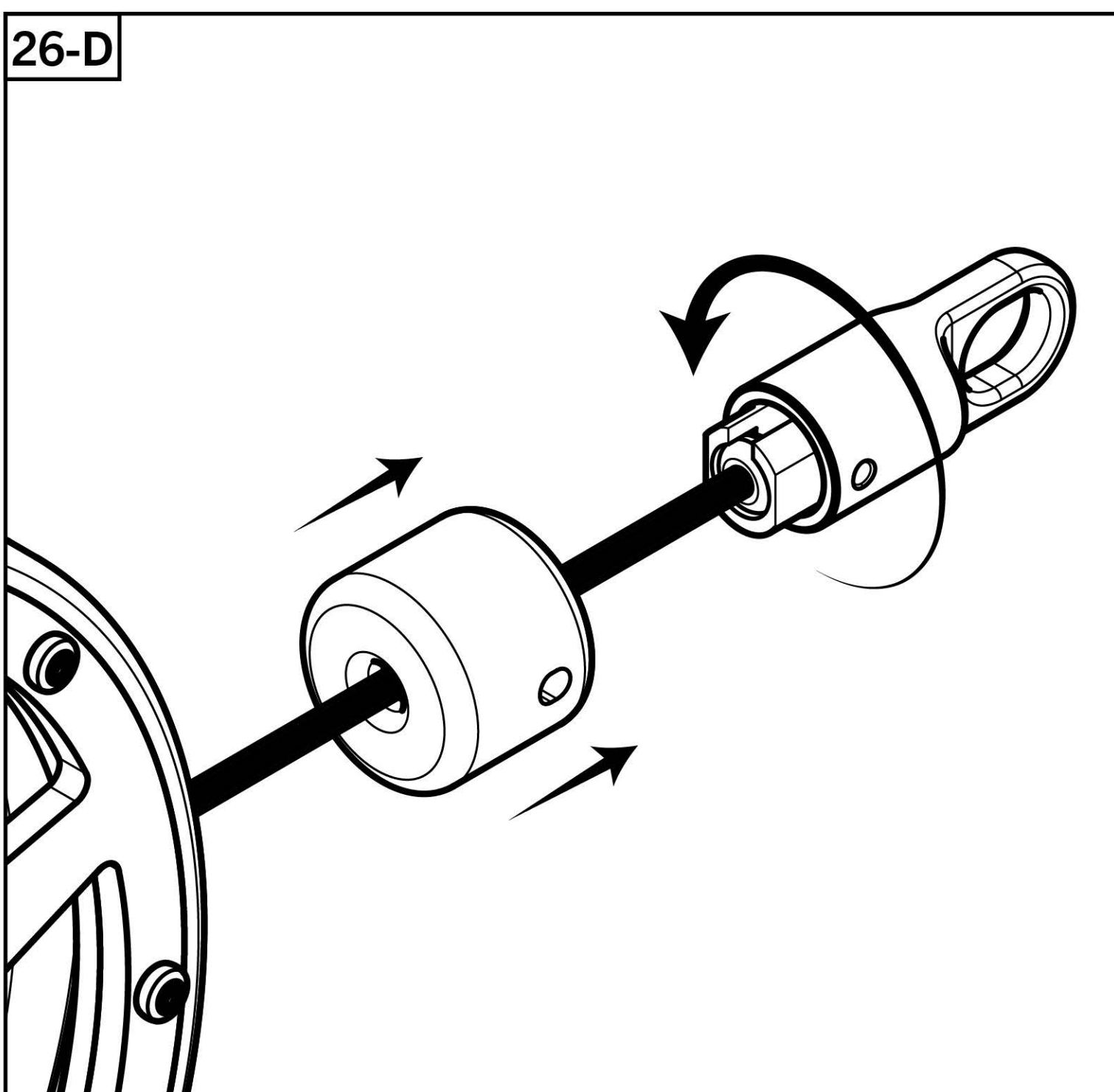
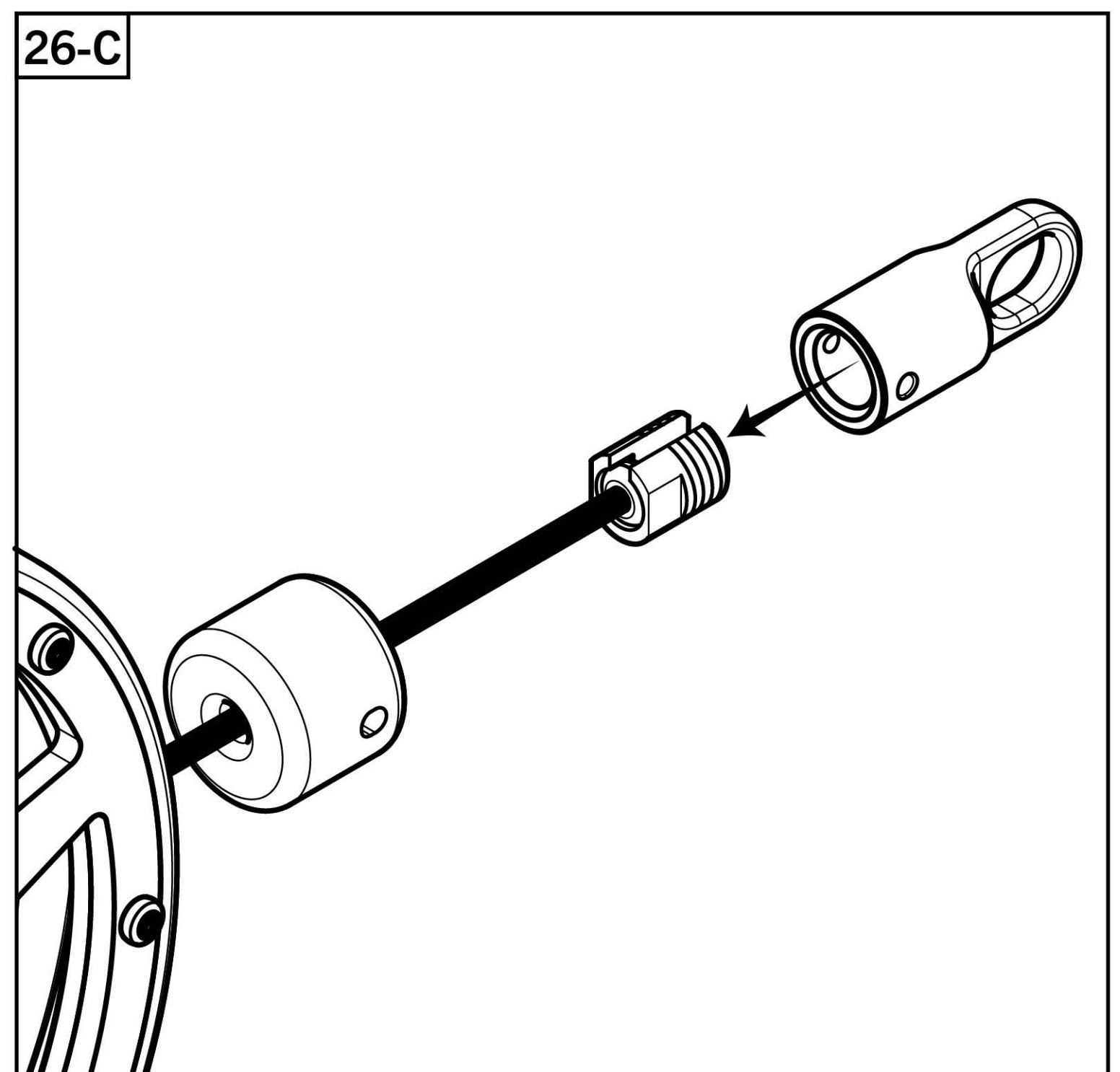
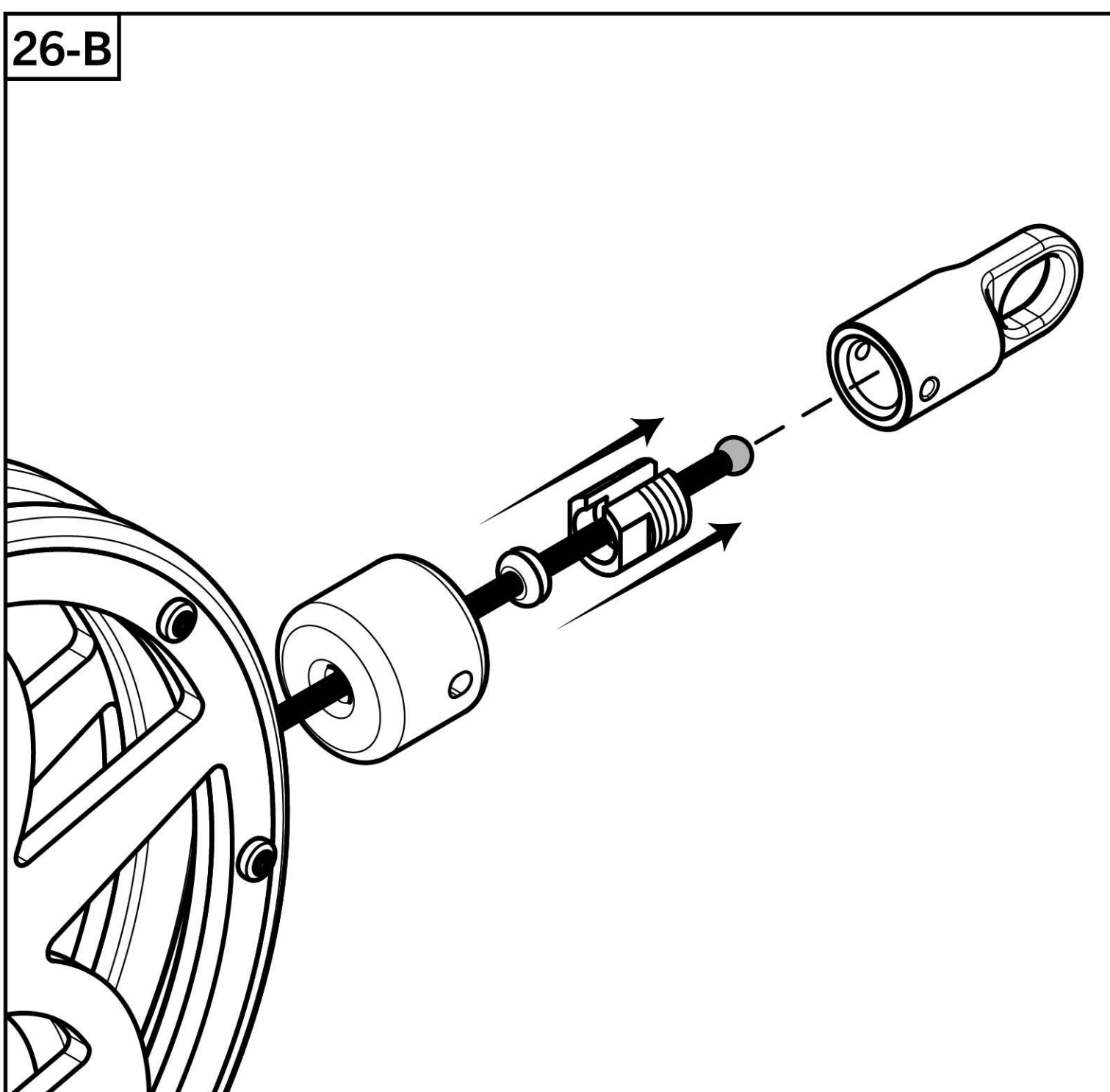
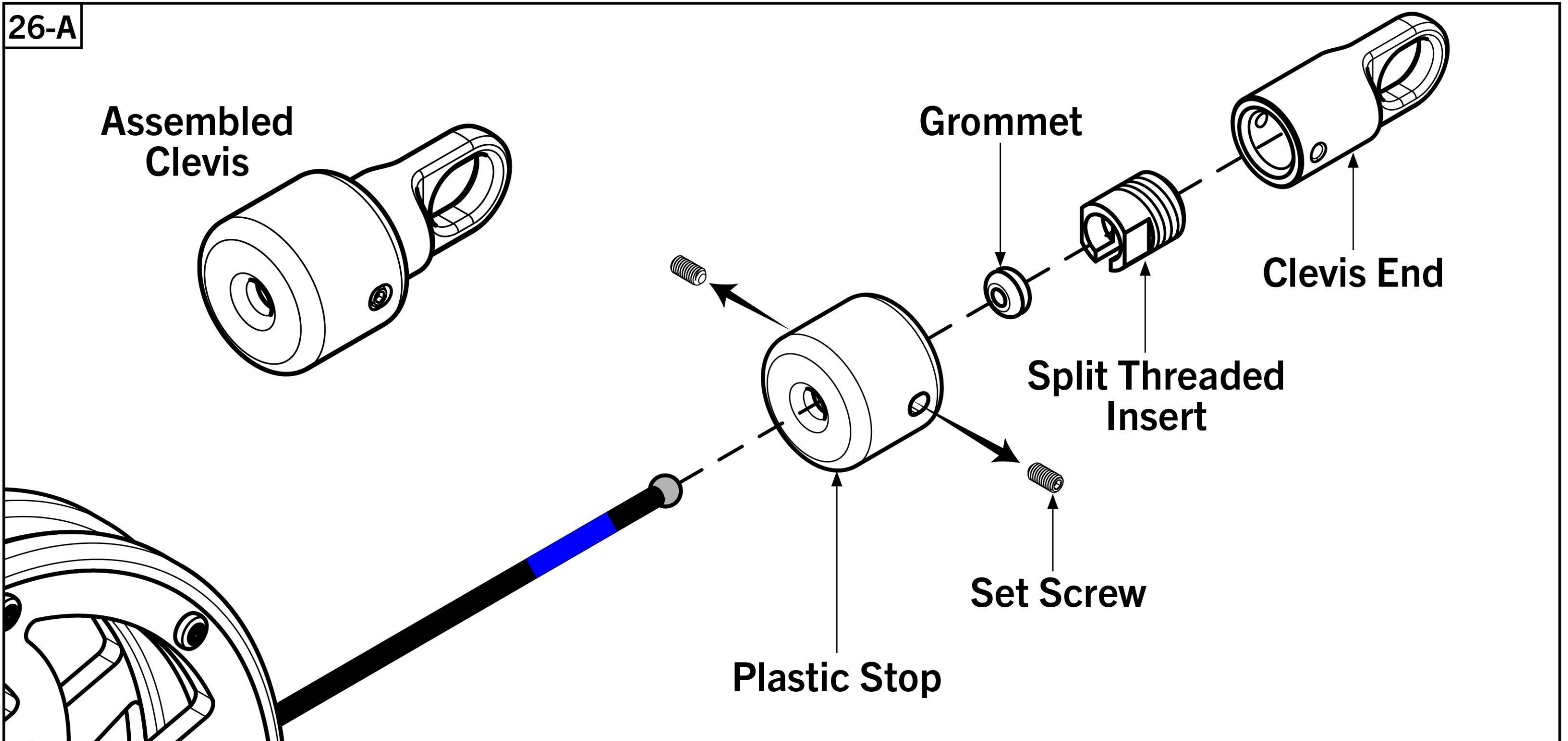

STEP 27

Note:

- Completely unwind and straighten out Lat Pull Cable [54] to remove any twists/kinks prior to installation.
- Next assemble the Lat Pull/Low Row cable indicated by the yellow indicator on Ball End of cable and corresponding yellow arrows shown in **STEPS 27-29**
- Feed the Ball End of Lat Pull Cable [54] up and over the pulley in Lat Pulldown Pulley Bracket [26] and then towards the back of the rack.
- Feed around the pulley in the top of Rear 3X3 Upright [17] and then all the way down, ensuring cable runs **INSIDE THE UPRIGHT**.

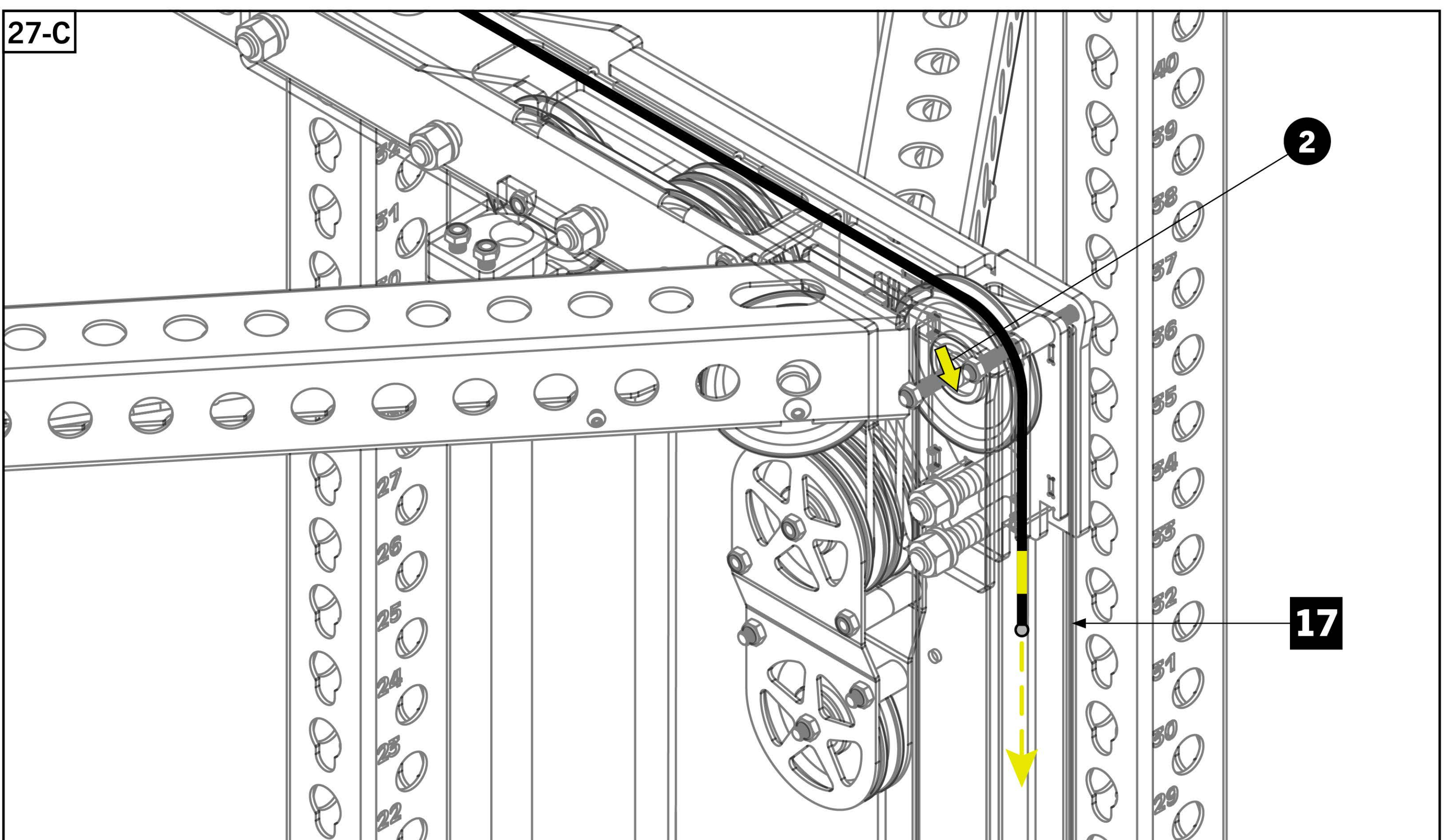
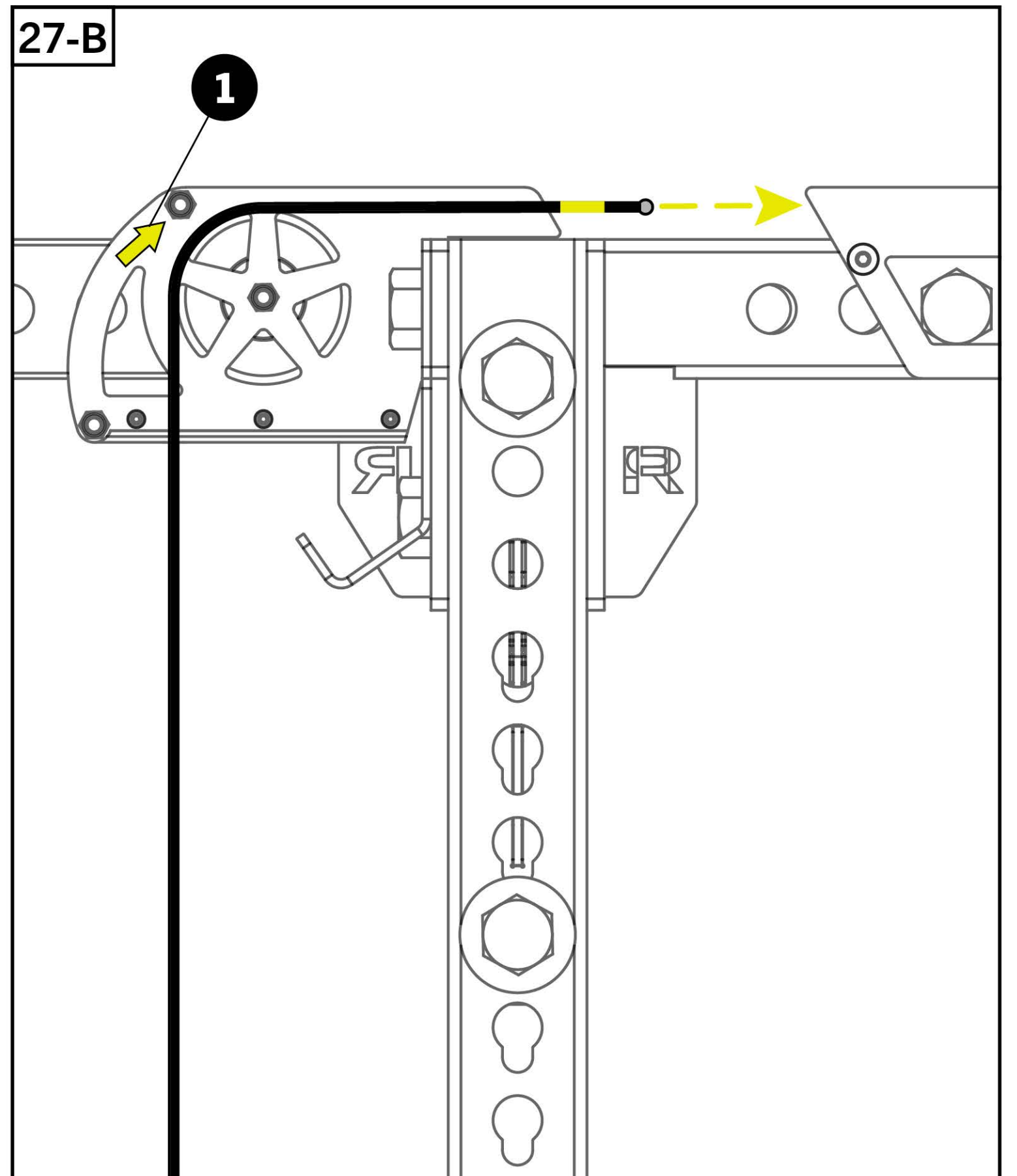
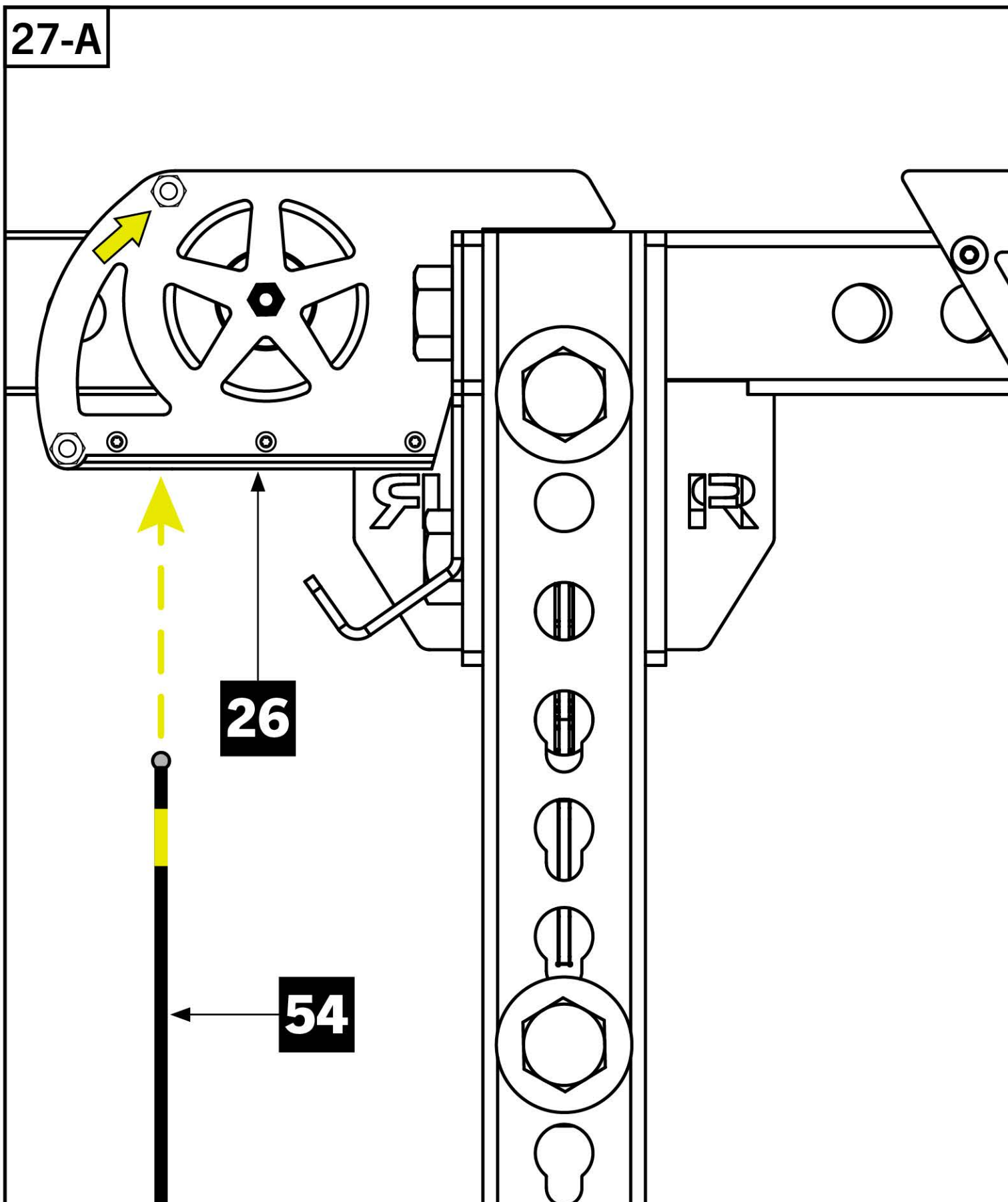
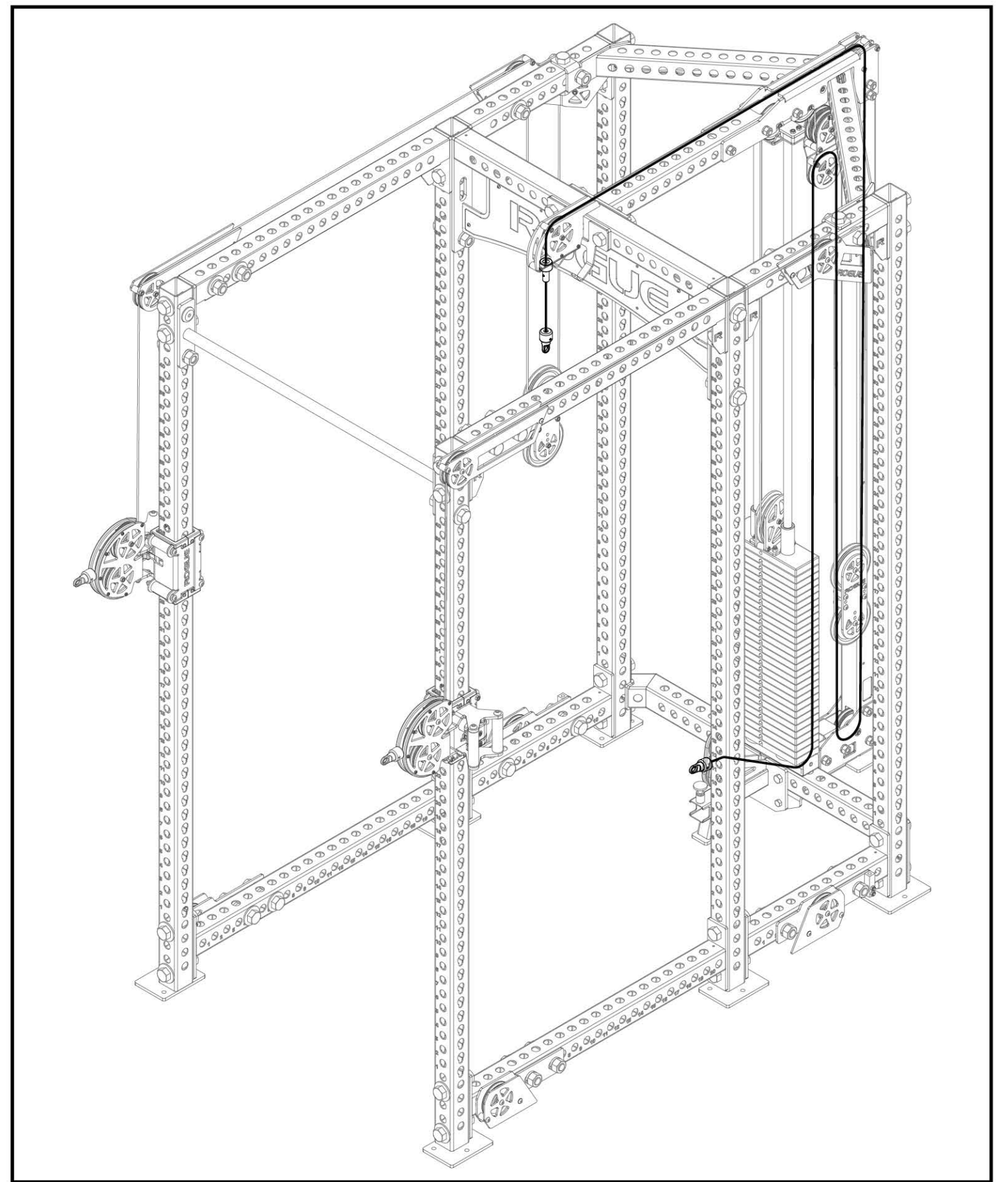

STEP 28

- Feeding cable around the rear pulley of the Low Rear Pulley Assembly [29] and up. This is easiest accomplished by pulling most of slack through rear window on Rear Upright and then re-inserting.
- Feed cable around the bottom pulley in the Rear Peanut Pulley Assembly [49] and then back down again.
- Feed around the front pulley in the Low Rear Pulley Assembly, continuing diagonally up underneath the Weight Stack through the cutouts on Low Row Crossmember [18] and towards the Low Row Assembly.

Note:

- Place finger through viewing windows to guide cable around pulleys as needed.

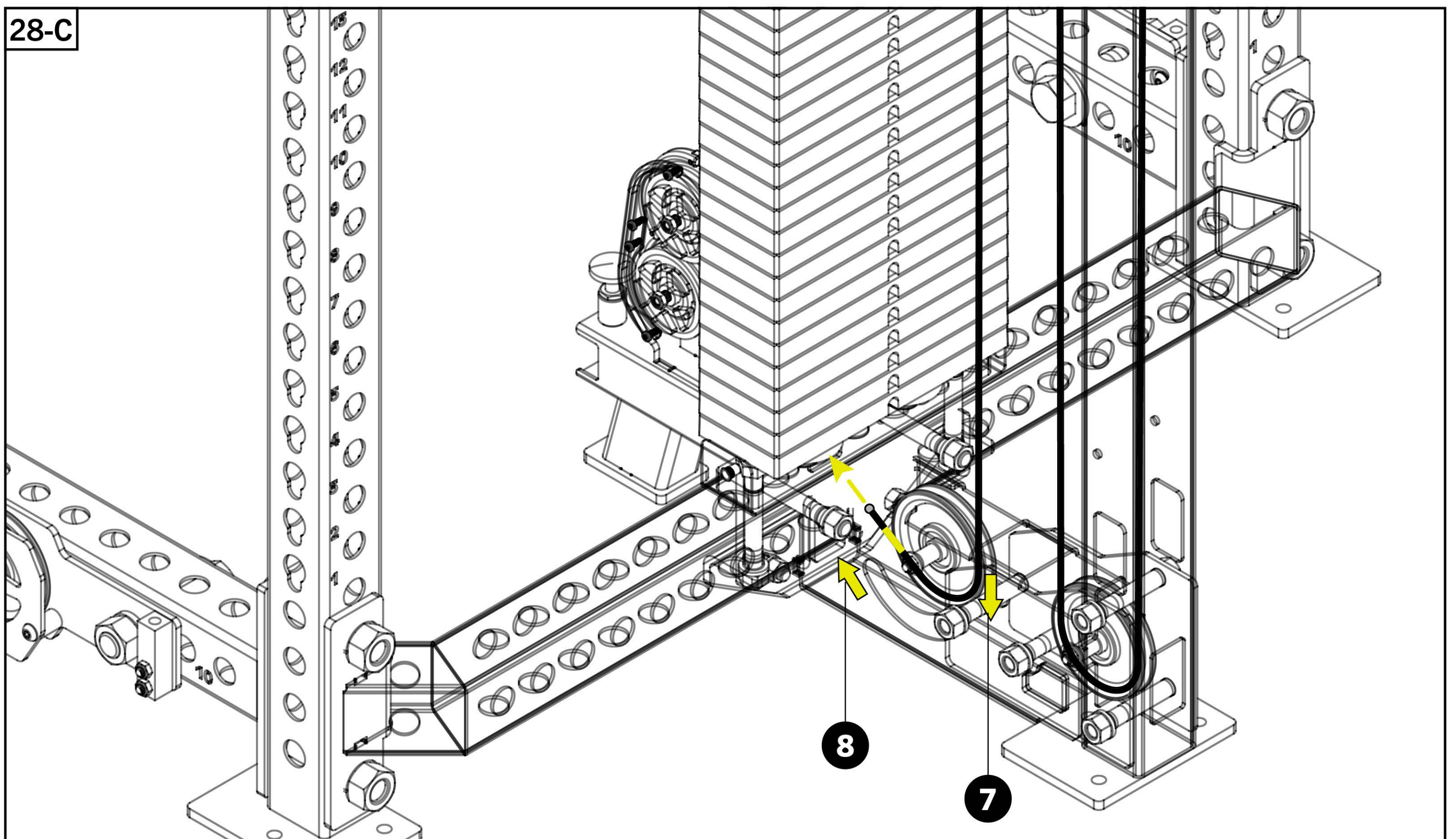
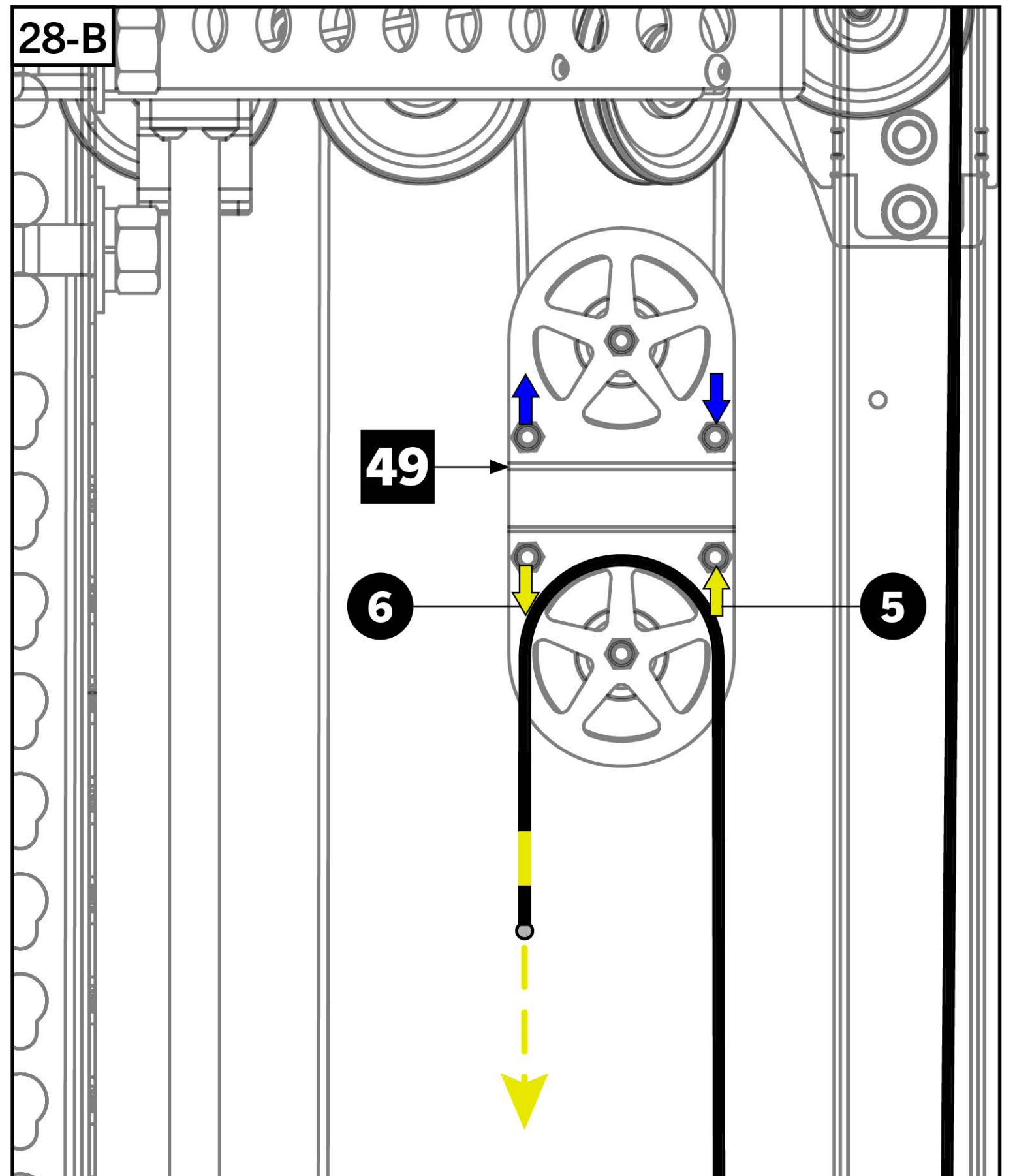
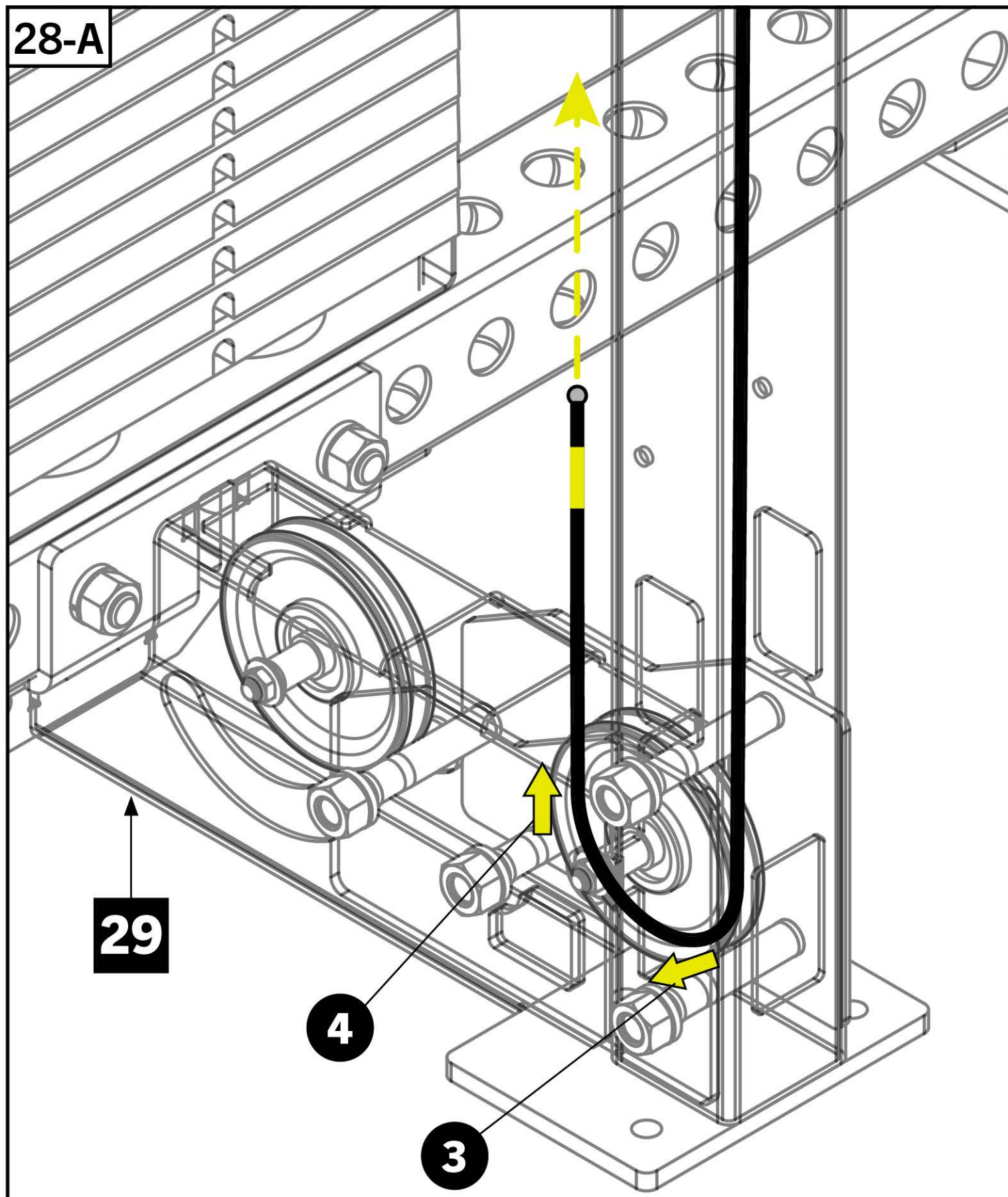
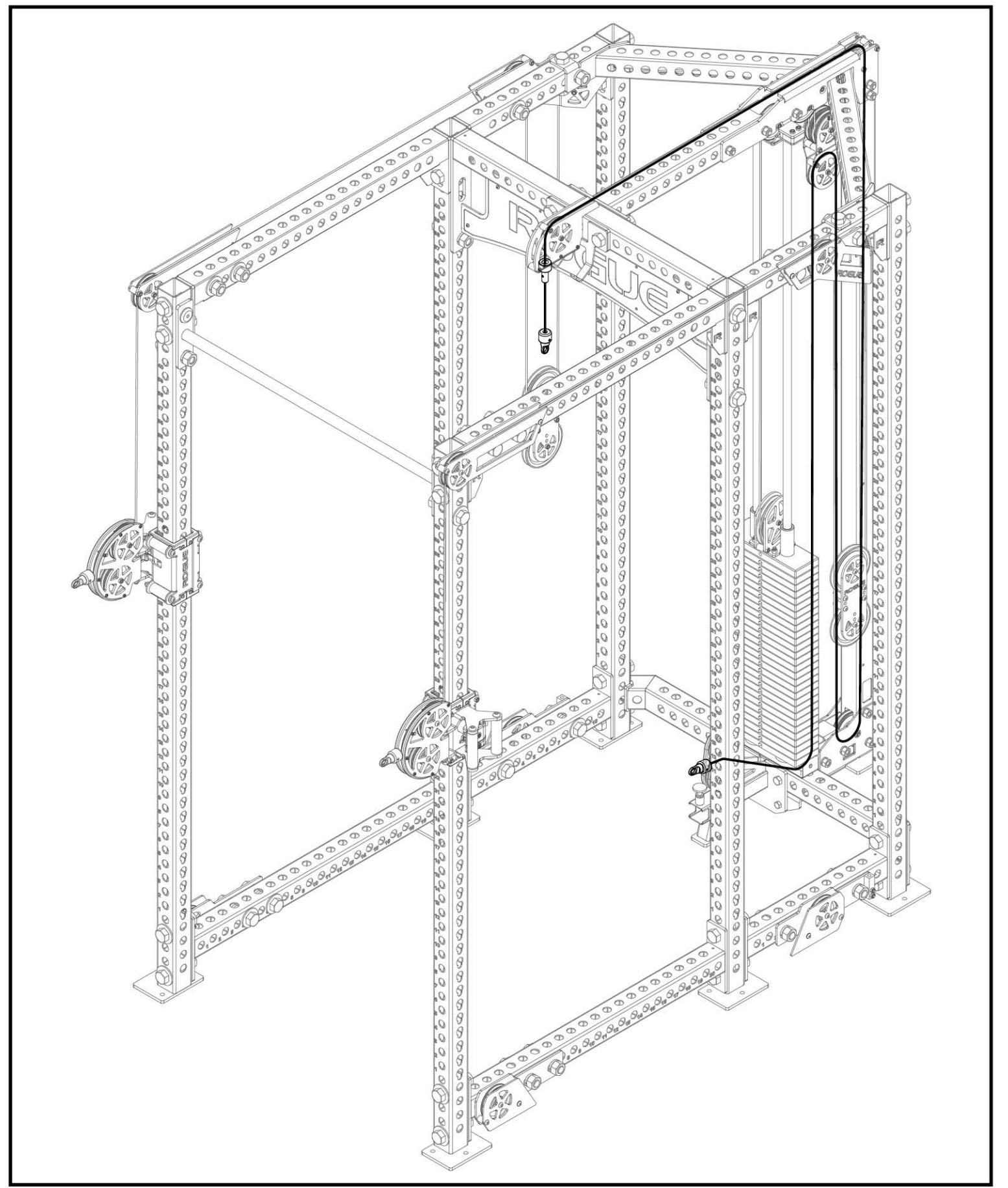

STEP 29

Tools Required:

- 3/32" Allen Key & 5/8" Wrench
- Feed cable out through the front of the Low Row Assembly [28], ensuring cable passes in between upper and lower pulleys.
- Remove yellow tag from Ball End of cable and pull cable out far enough to assemble Clevis.
- Assemble Clevis onto ball end of cable using the same procedure described on **STEP 26**.

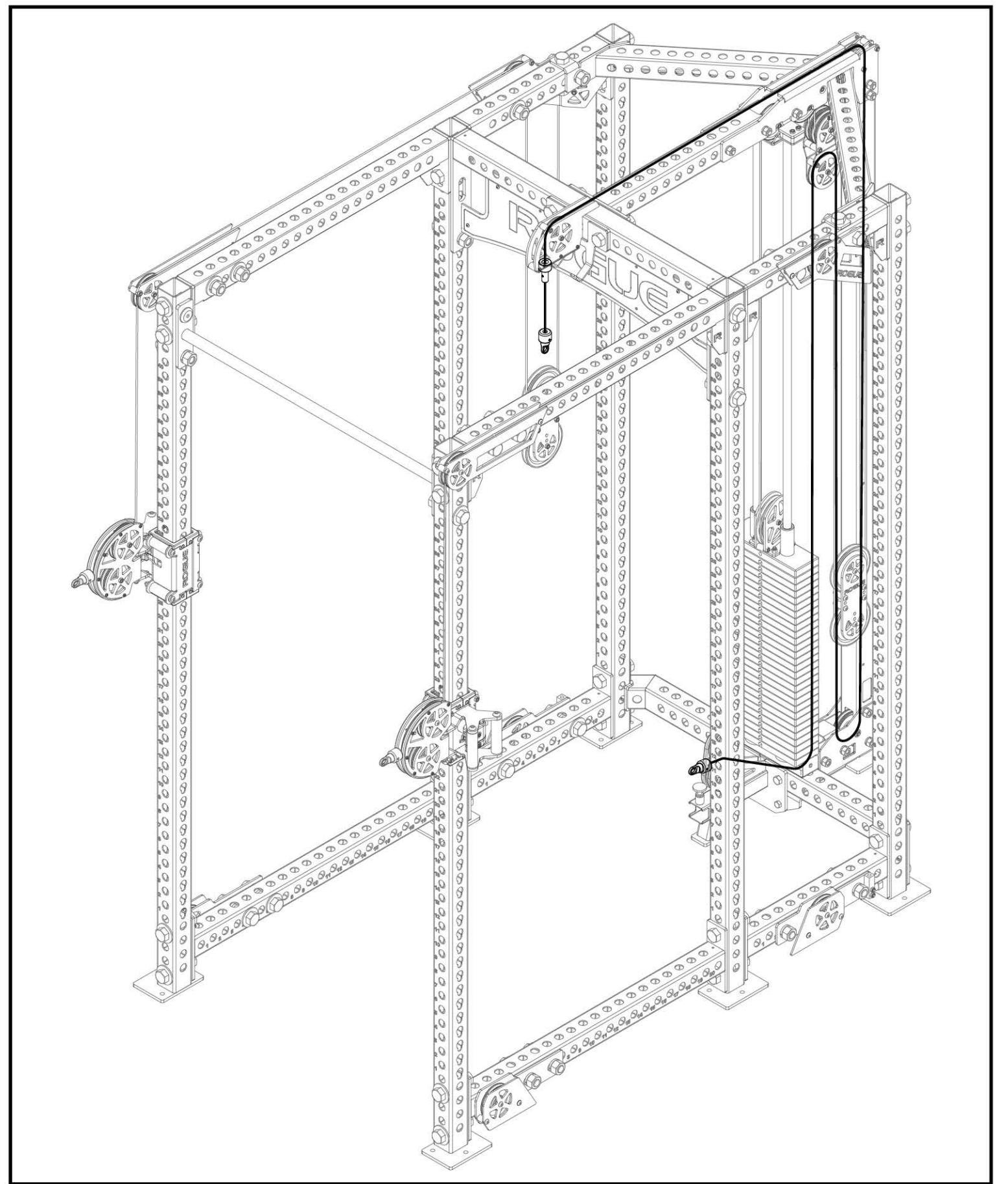

29-A

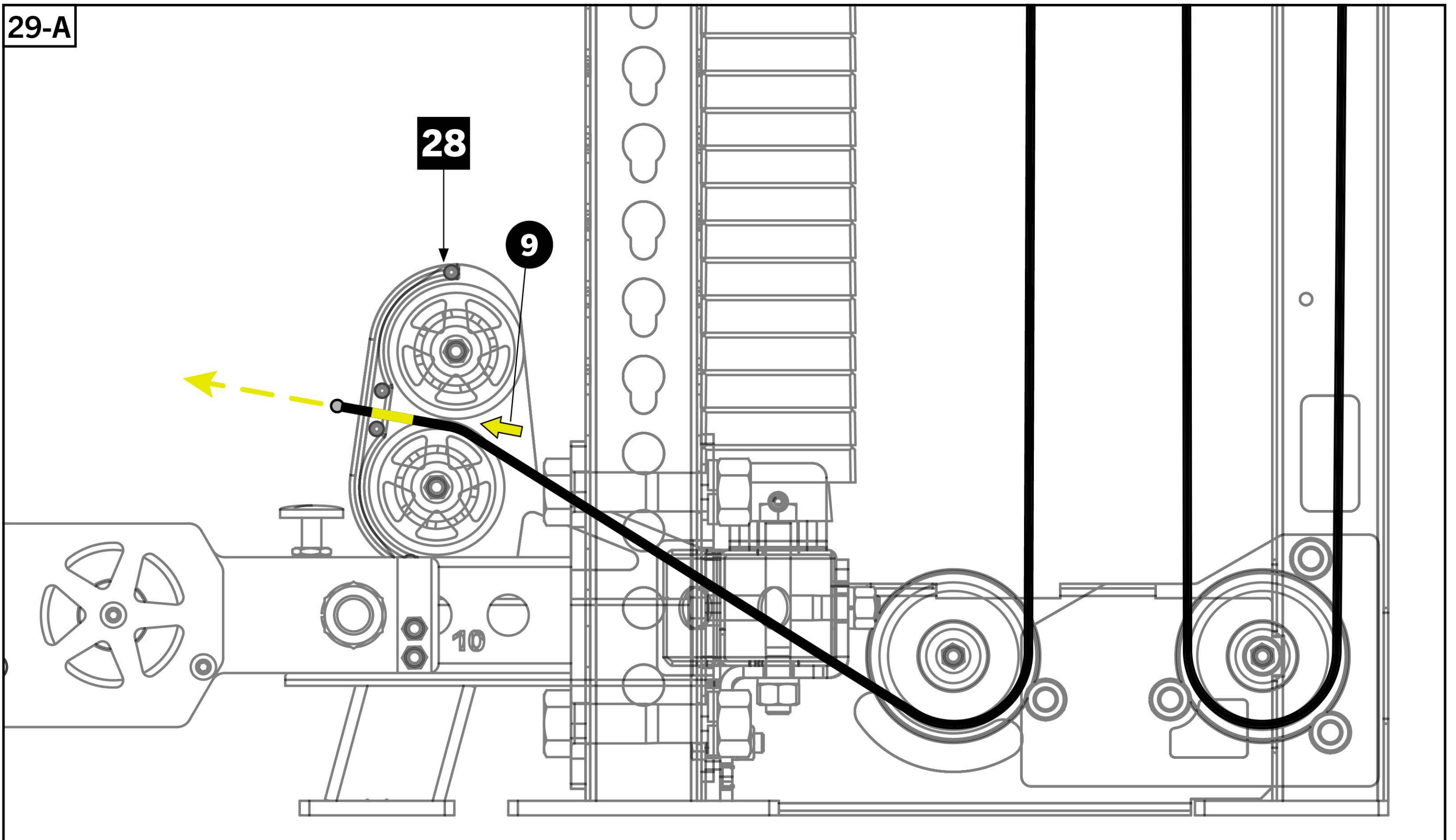

29-B

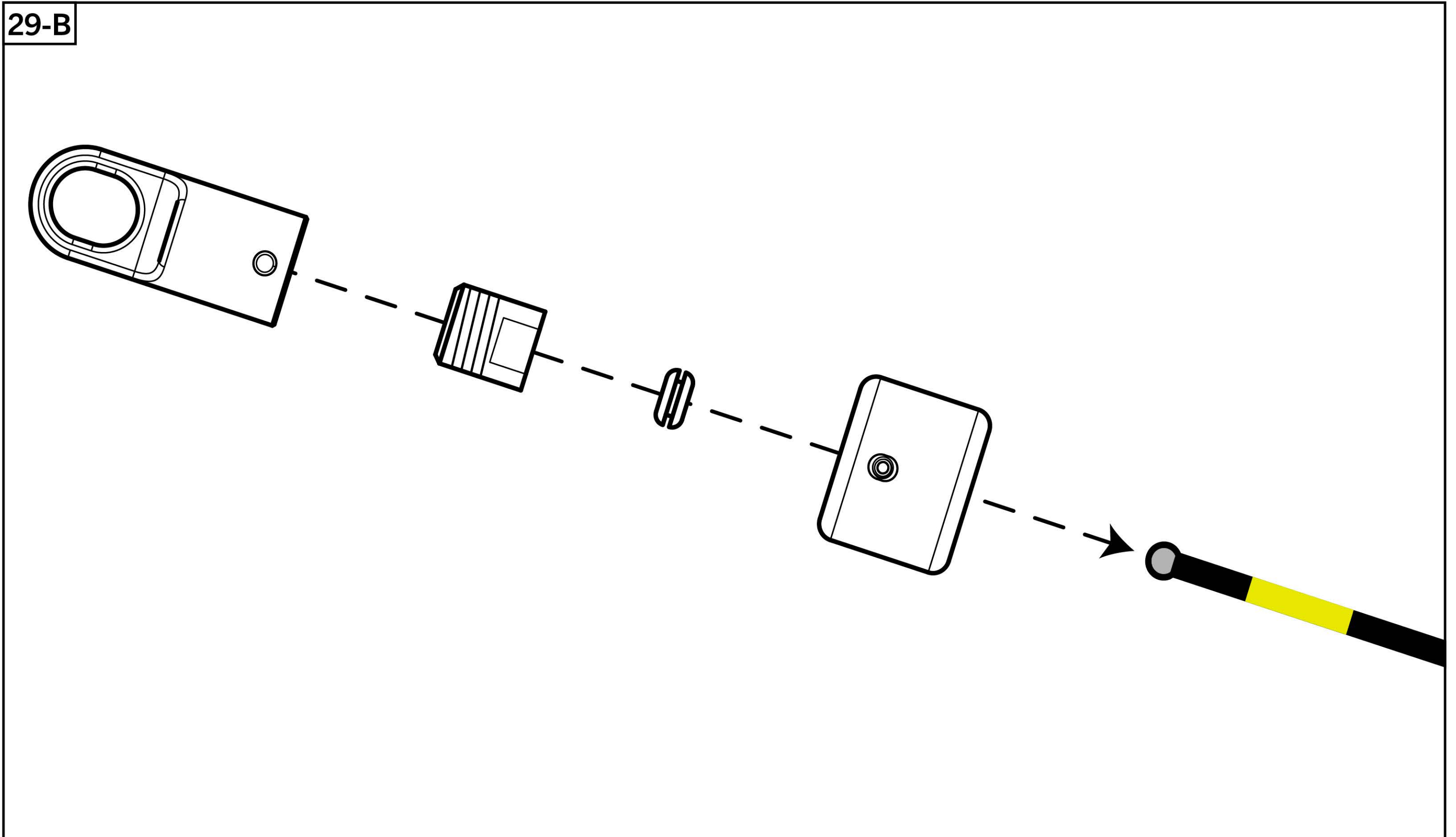

STEP 30

Tools Required:

- 7/32" Allen Key & 9/16" Wrench
- Remove Plastic Cable Retainers from **all** four Bottom Side Pulley Assemblies by removing 3/8" Button Head Screws.
- Remove only the lower Plastic Cable Retainers from both Side Peanut Pulleys [50].
- Hardware will be re-installed on **STEP 33**.

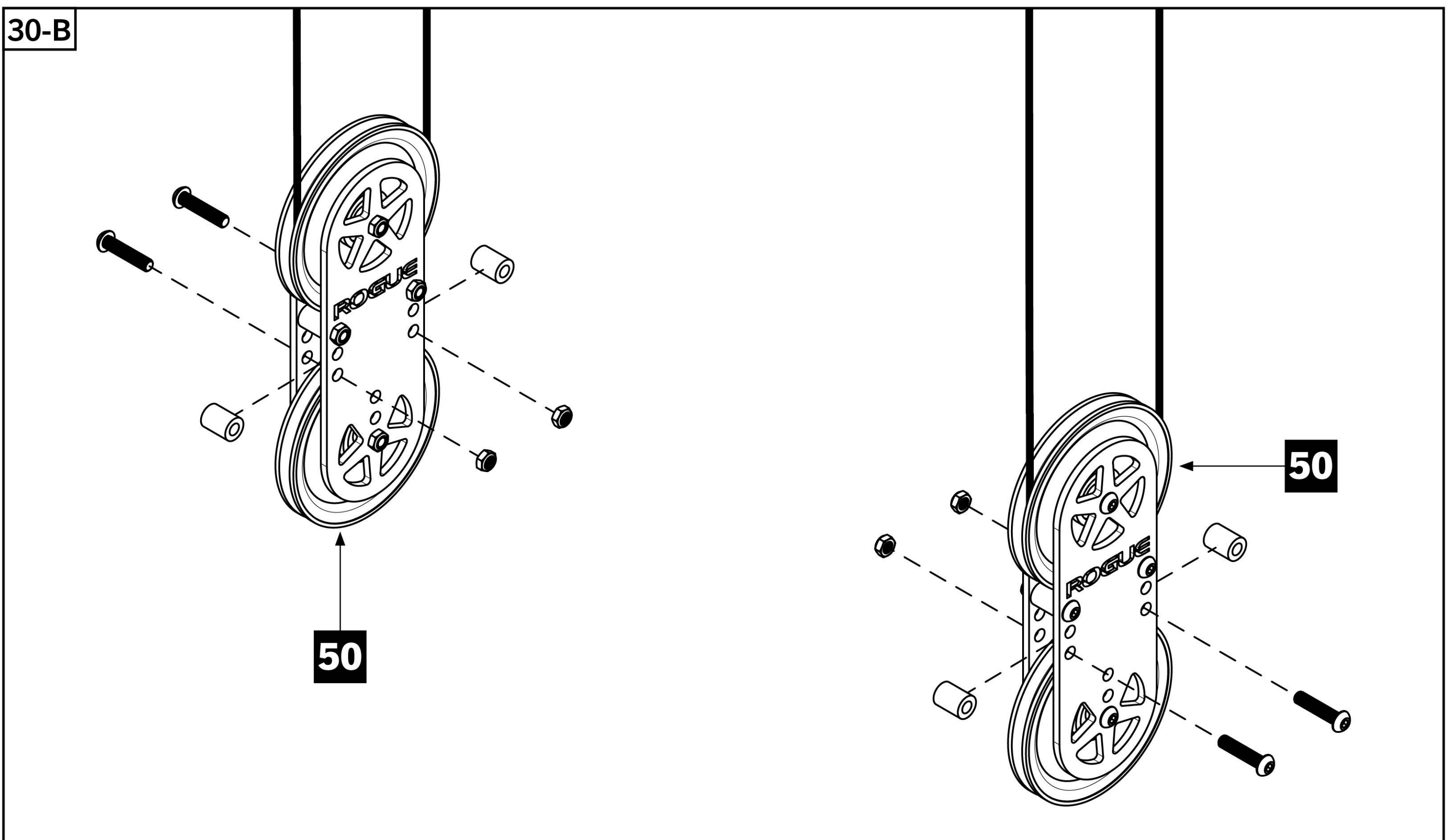
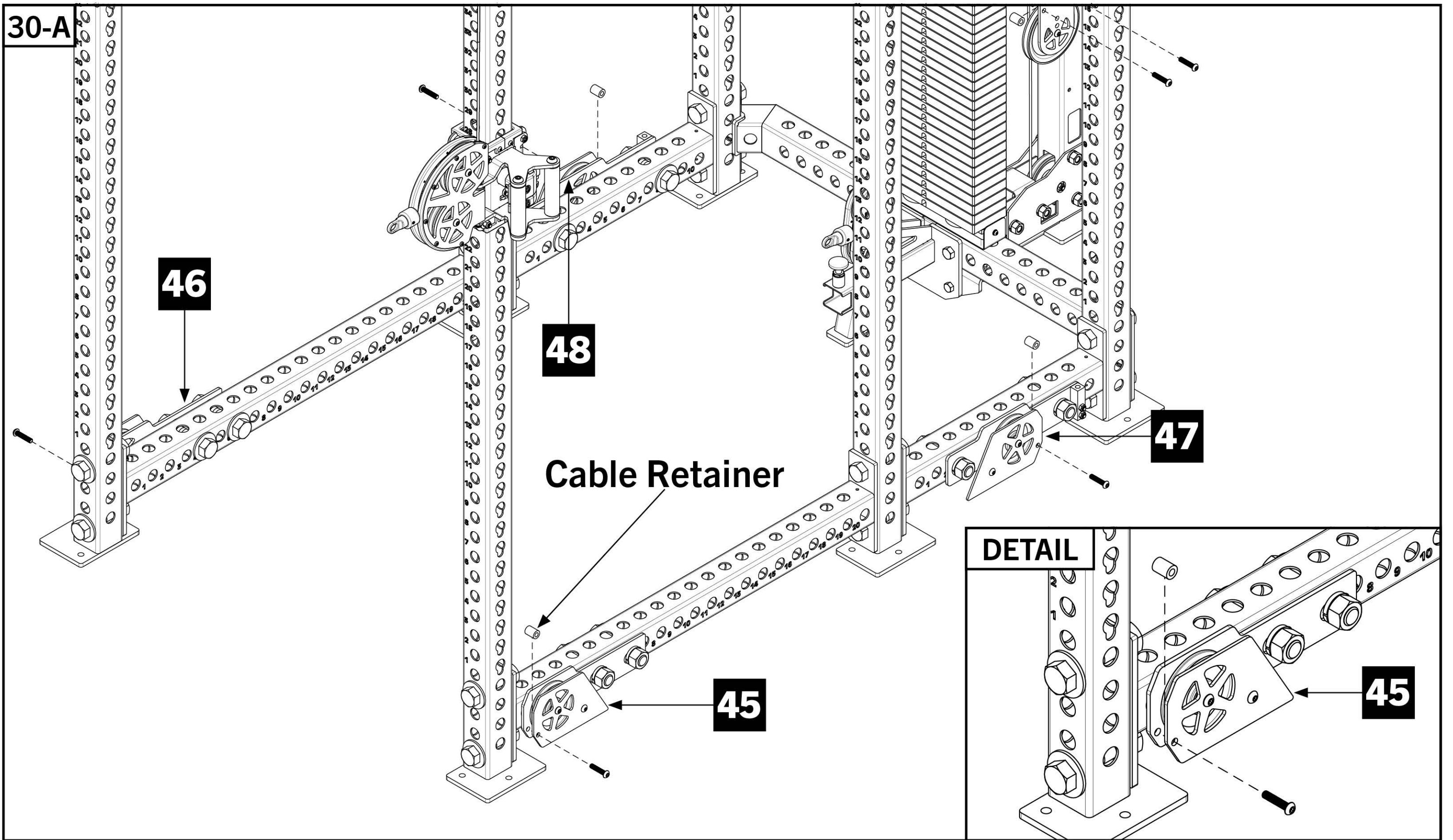
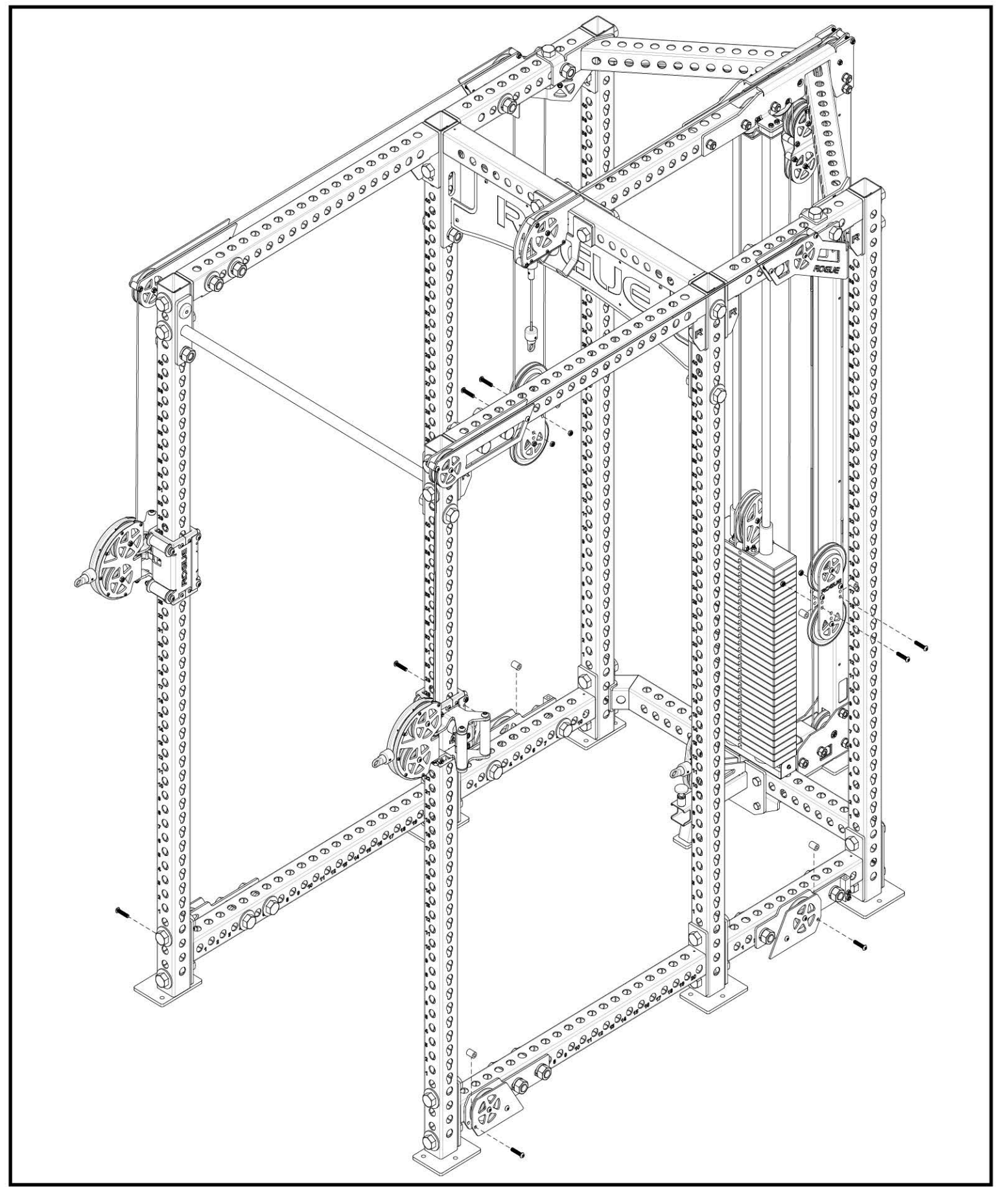

STEP 31

Tools Required:

- 3/4" Wrench
- Assemble one of the included Low Side Cables [55] (red tag) onto RH side of rack by inserting the tagless end into stop block on back of Swivel Trolley RH [19].
- Loosen the hex nut if needed to ensure approximately 1/2" of threads are showing between the bolt head and nut.
- Tighten the bottom bolt head until the nut is tight against the stop block.
- Feed the other end of cable with red tag down around the pulley on Bottom Front Pulley Assembly and continue towards back of rack.

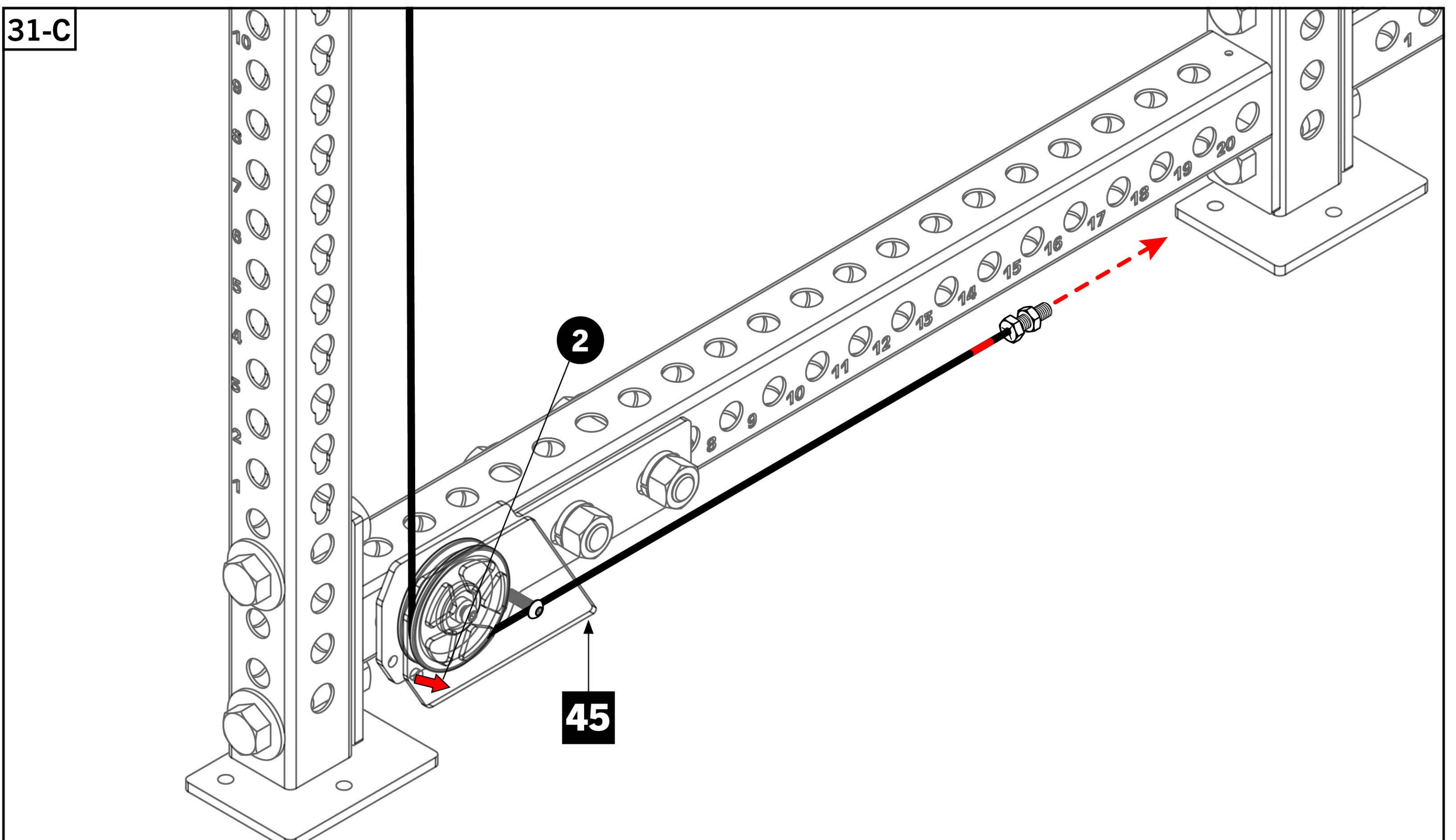
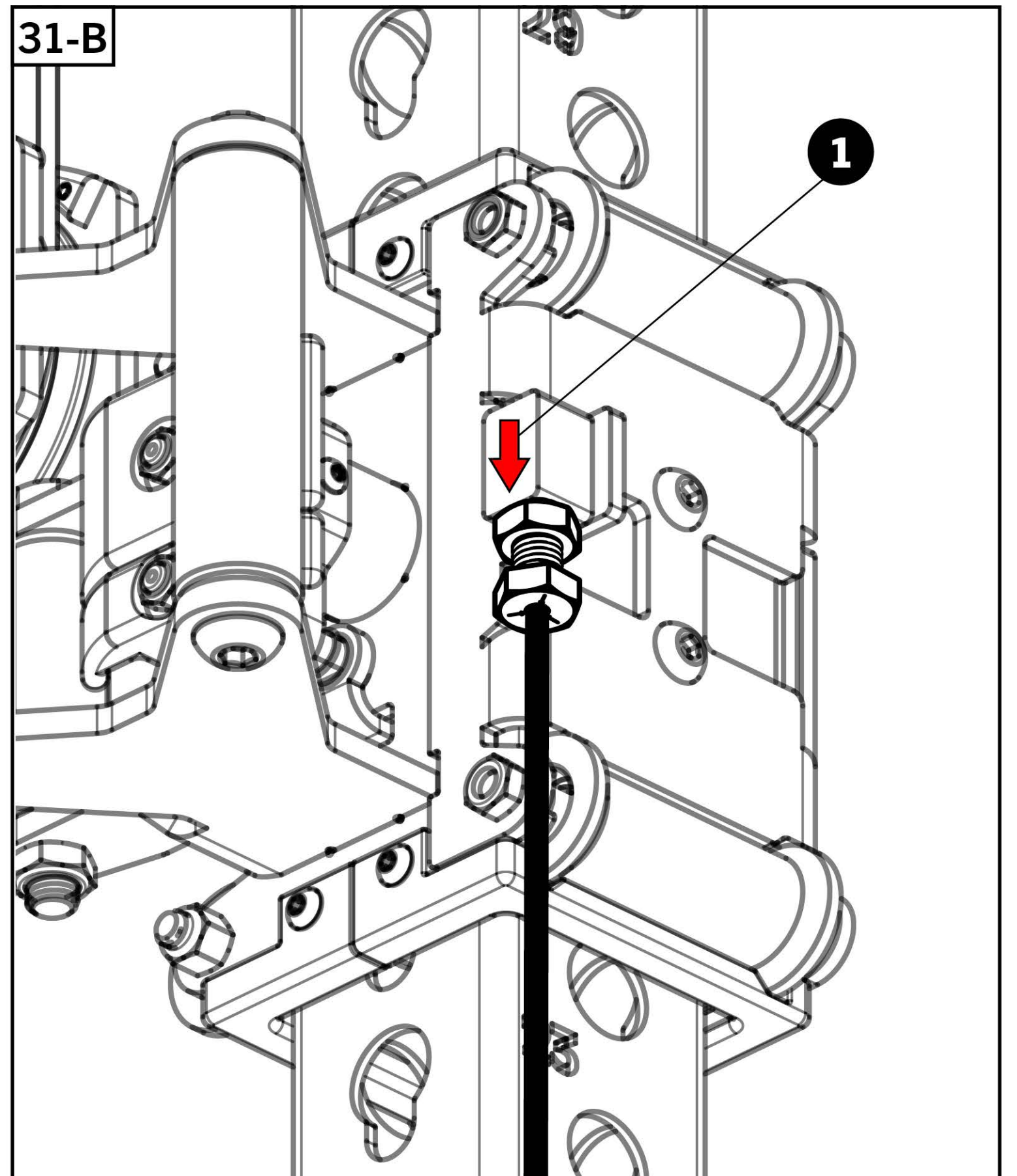
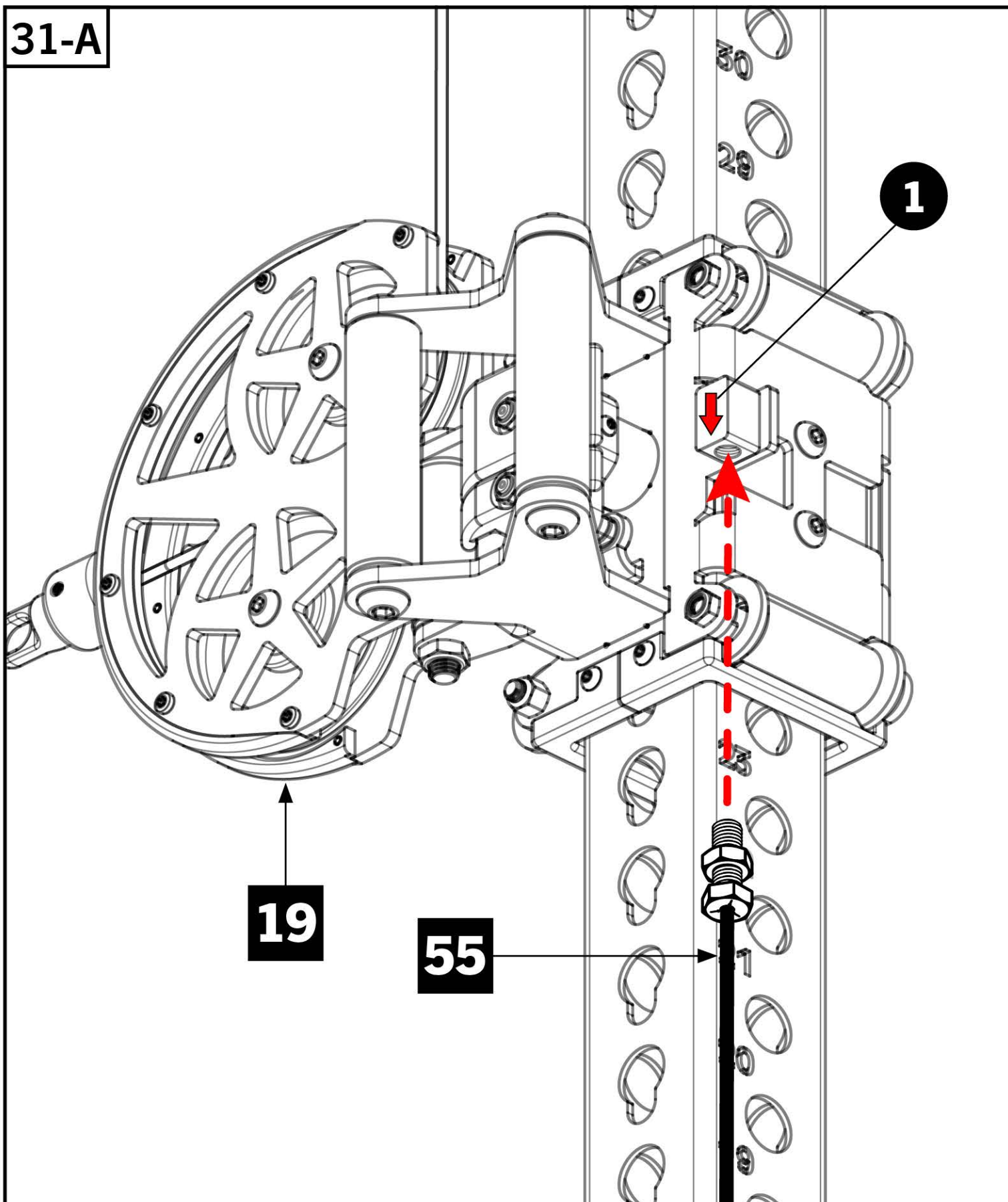
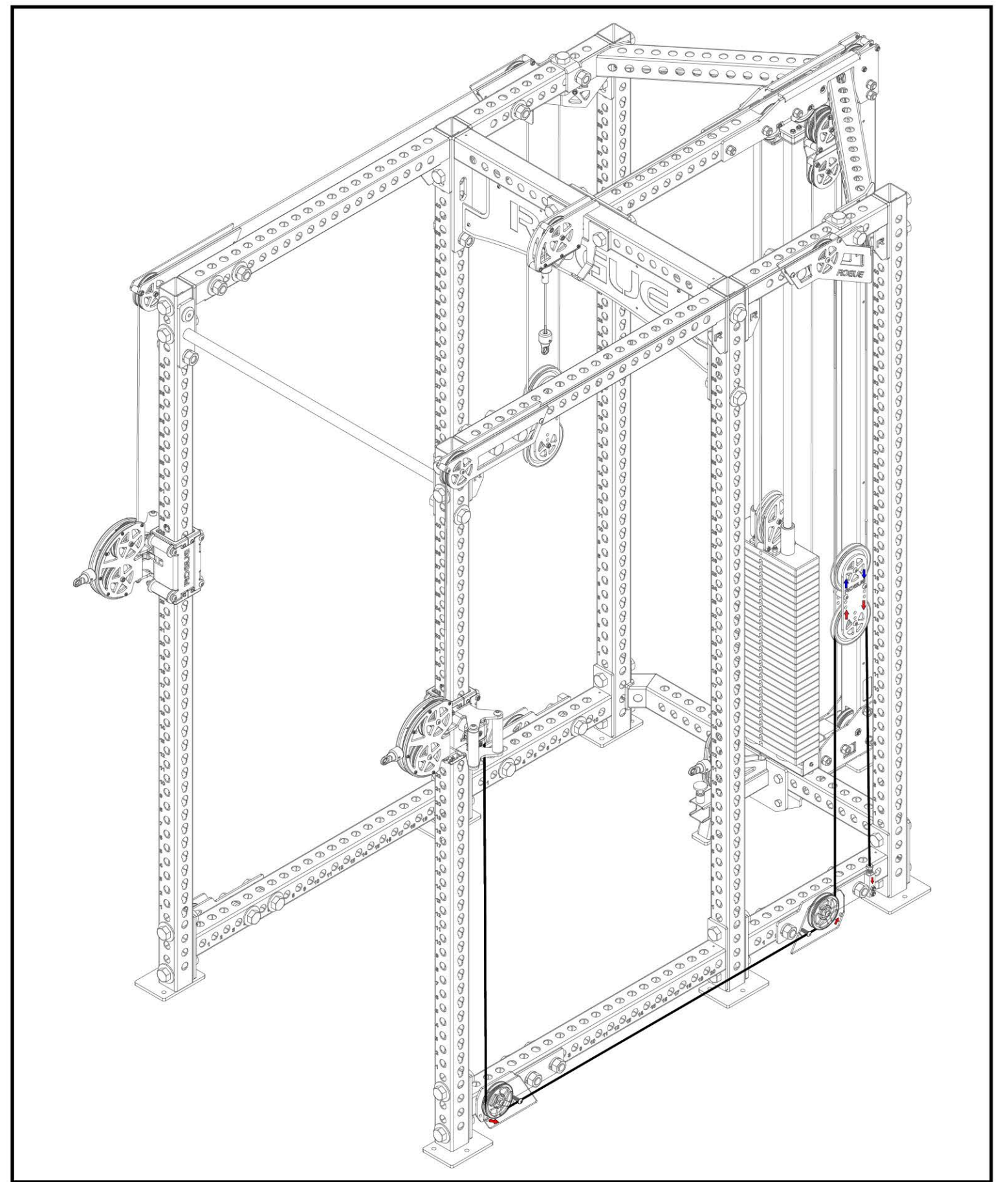

STEP 32

Tools Required:

- 3/4" Wrench
- Continue feeding around the pulley on Bottom Rear Pulley Assembly and up around the lower Side Peanut Pulley [50], following the arrow indicator directions.
- Insert threaded end into stop block at the back of Bottom Rear Side Pulley Assembly [47] and screw tight, ensuring 1/2" of threads showing between 3/4" bolt head and hex nut.

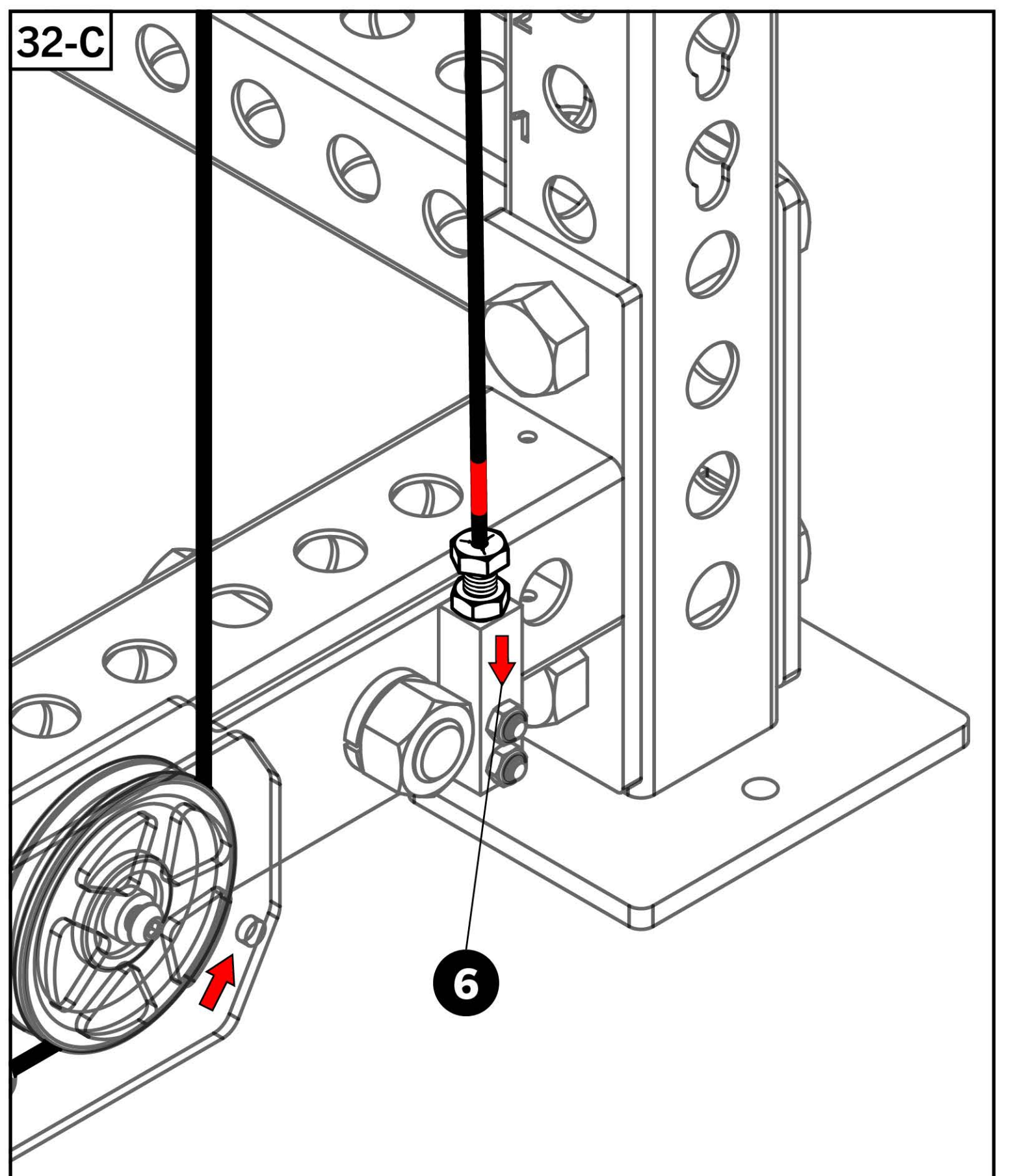
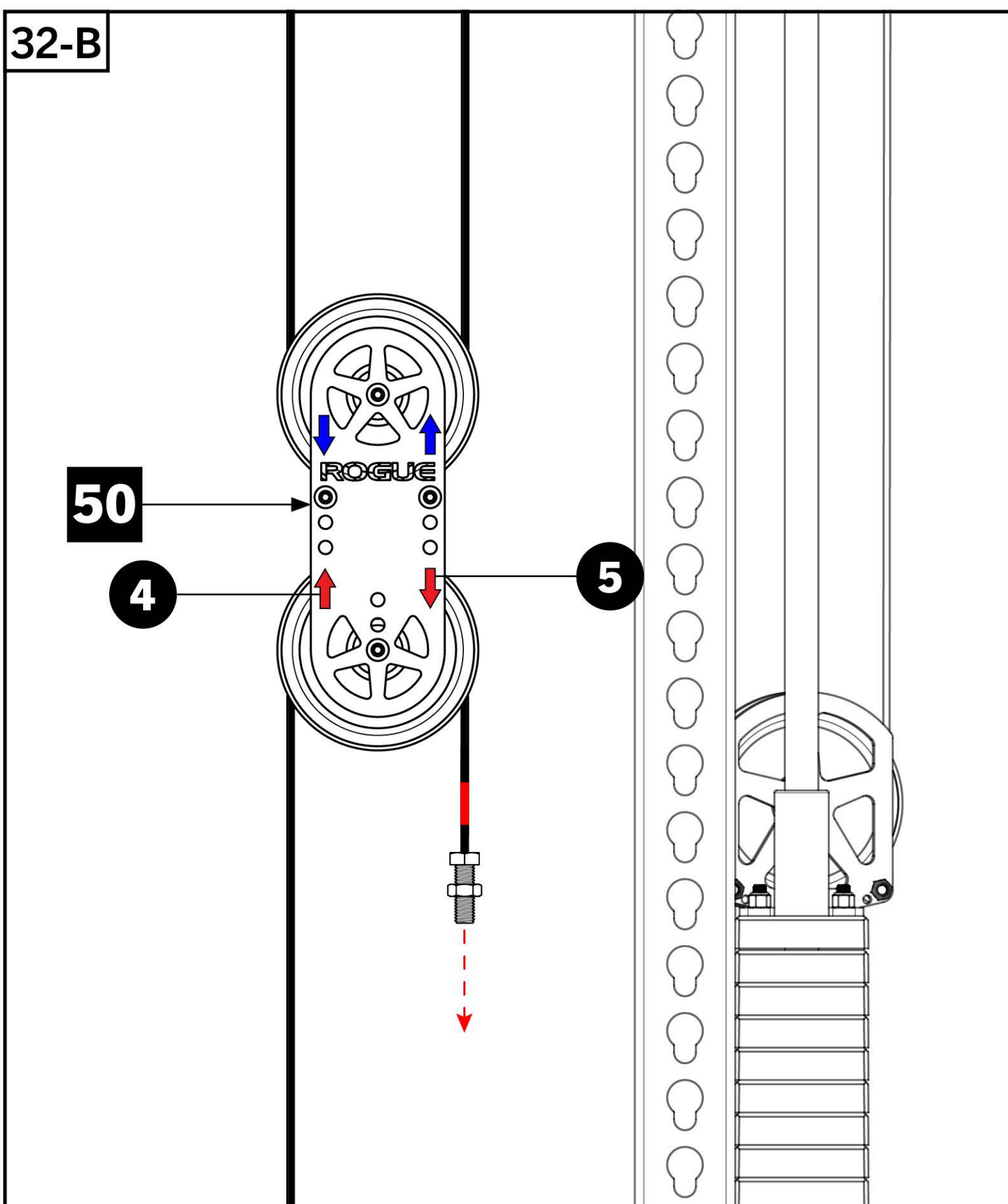
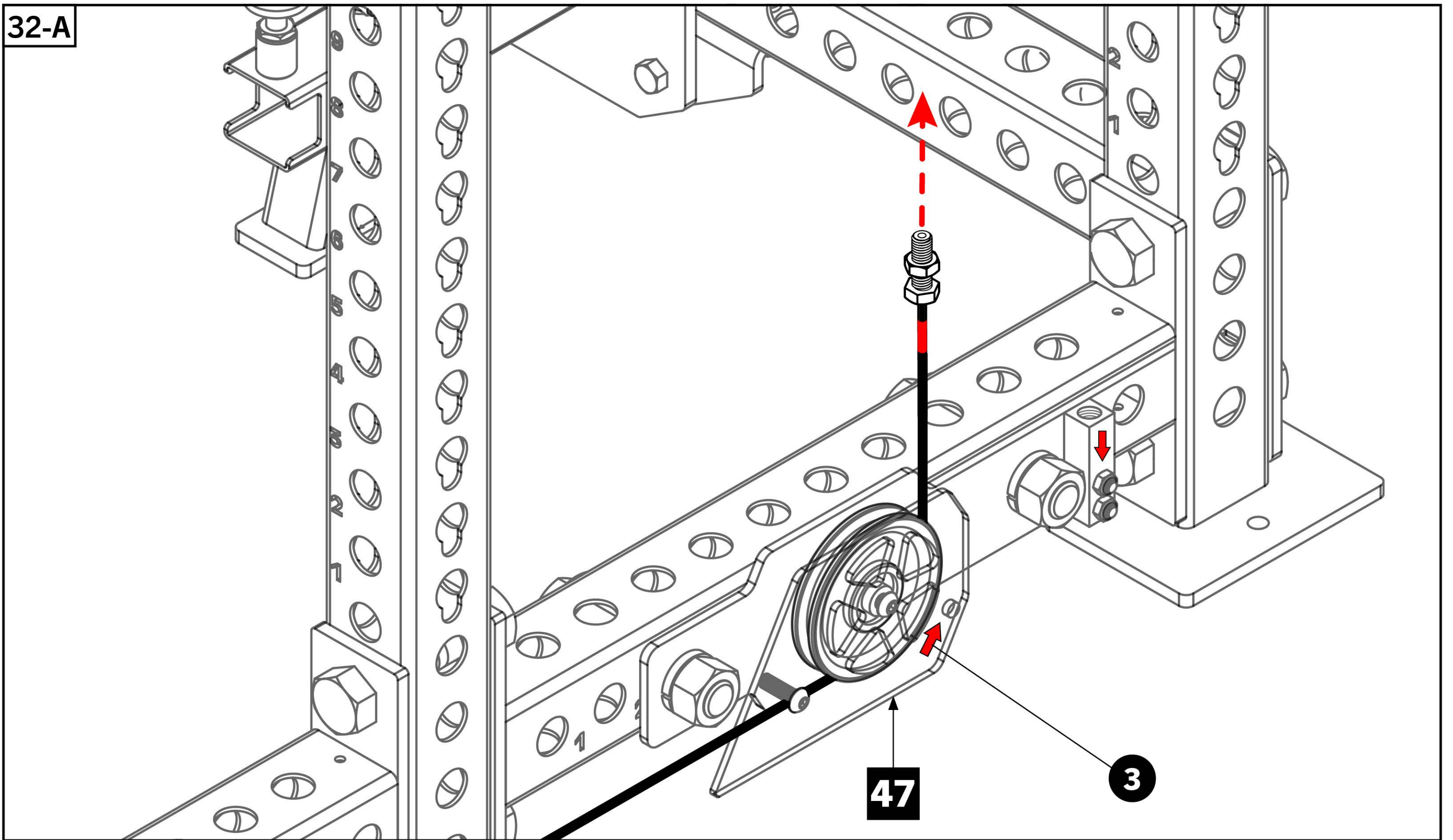
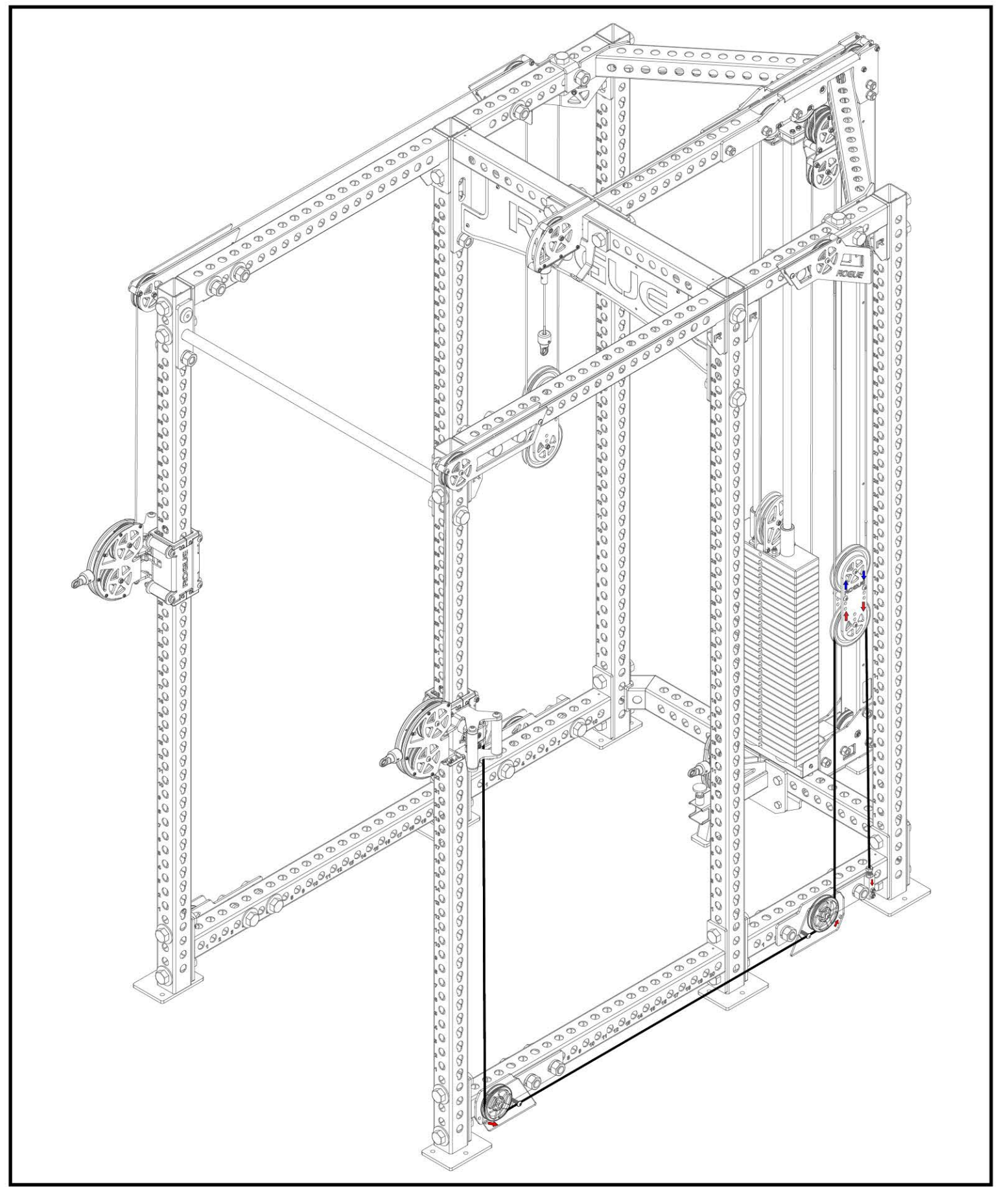

STEP 33

Tools Required:

- 3/4" Wrench
- **33-A:** Follow **STEP 31 & 32** again to assemble the remaining Low Side Cable (red tag) on the **Left Hand side of rack**.
- Start at stop block on the Swivel Trolley LH [20] and end at stop block on the Bottom Rear Side Pulley - LH [48].

Tools Required:

- 7/32" Allen Key & 9/16" Wrench
- **33-B:** Re-install Plastic Cable Retainers on **all four** Bottom Side Pulley Assemblies and both Side Peanut Pulleys. Fully Tighten.

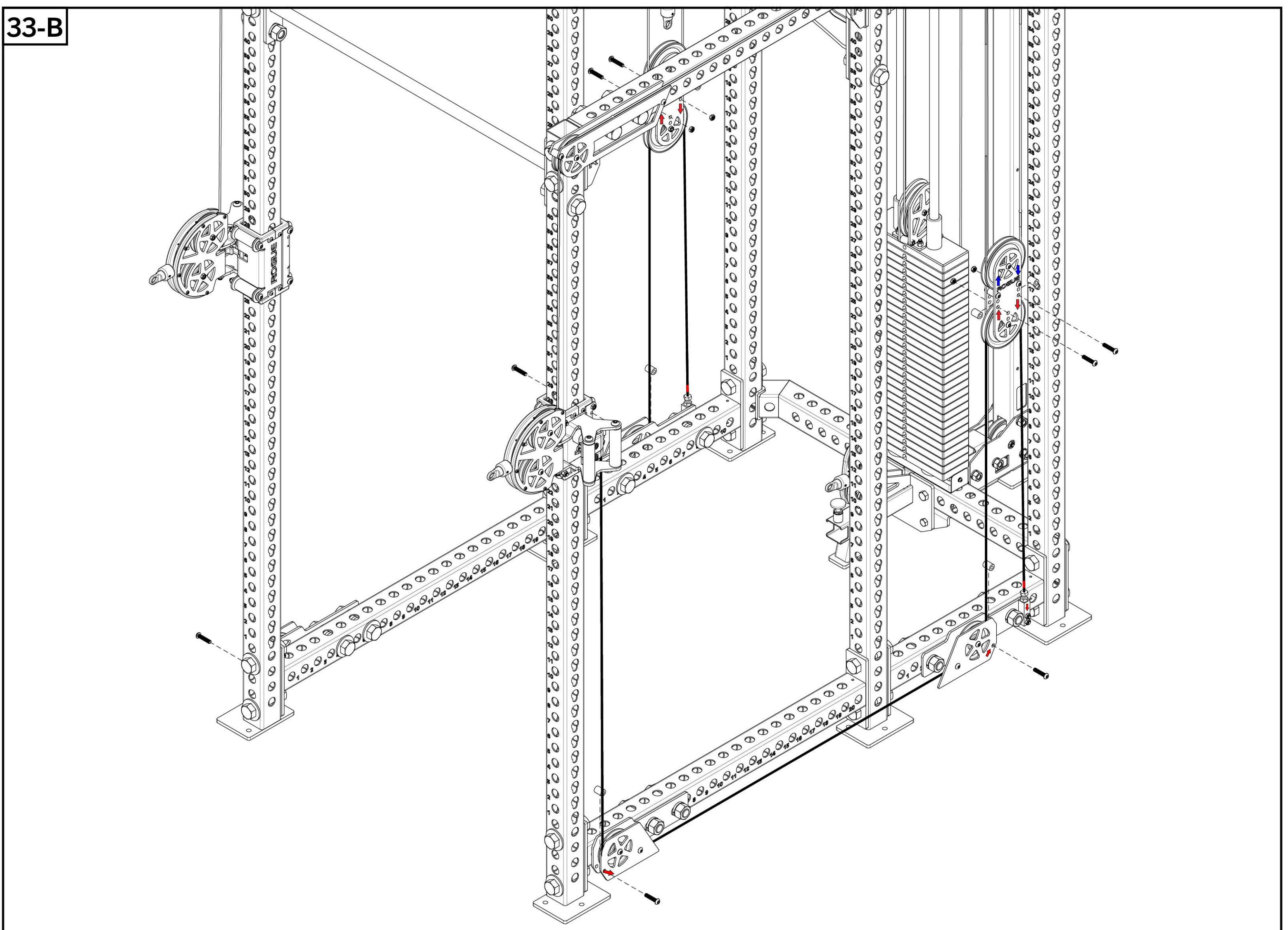
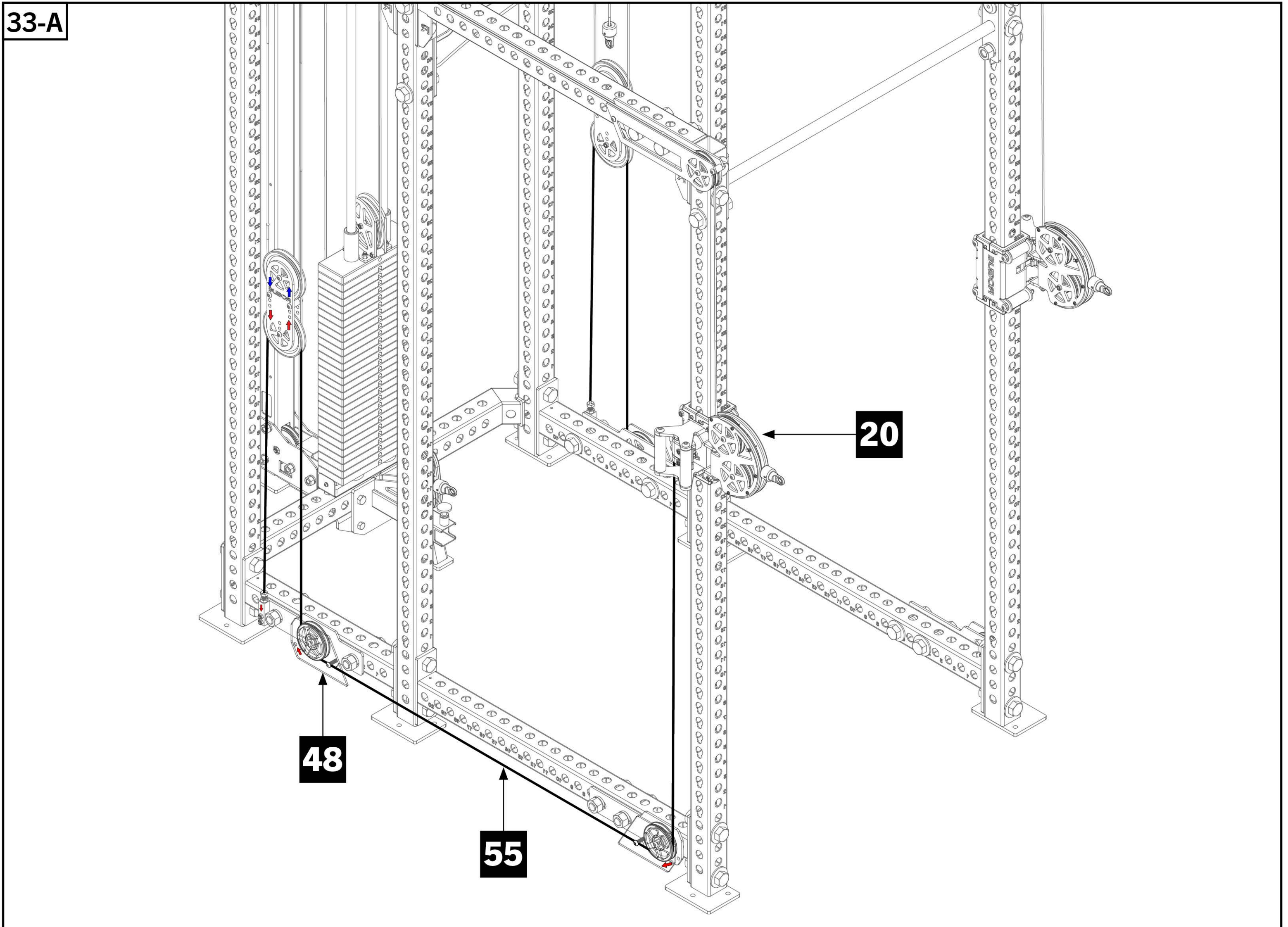

STEP 34

Tools Required:

- 7/32" Allen Key
- Remove eight 3/8" Button Head Screws located on the rear of the Front Side Pulley Assemblies and the front of the Rear Side Pulley Assemblies.
- Fasten the Top Cable Cover Rails [39] between the Front and Rear Top Side Pulley Assemblies by aligning holes and reinstalling the 3/8" Button Head Screws.
- Repeat this process on the bottom of your rack to install the Low Cable Cover Rails [40].
- **!** Note the orientation of the Rogue logos in relation to the rack. Ensure the cable opening is facing upward on the Top Cable Covers and downward on the Low Covers.

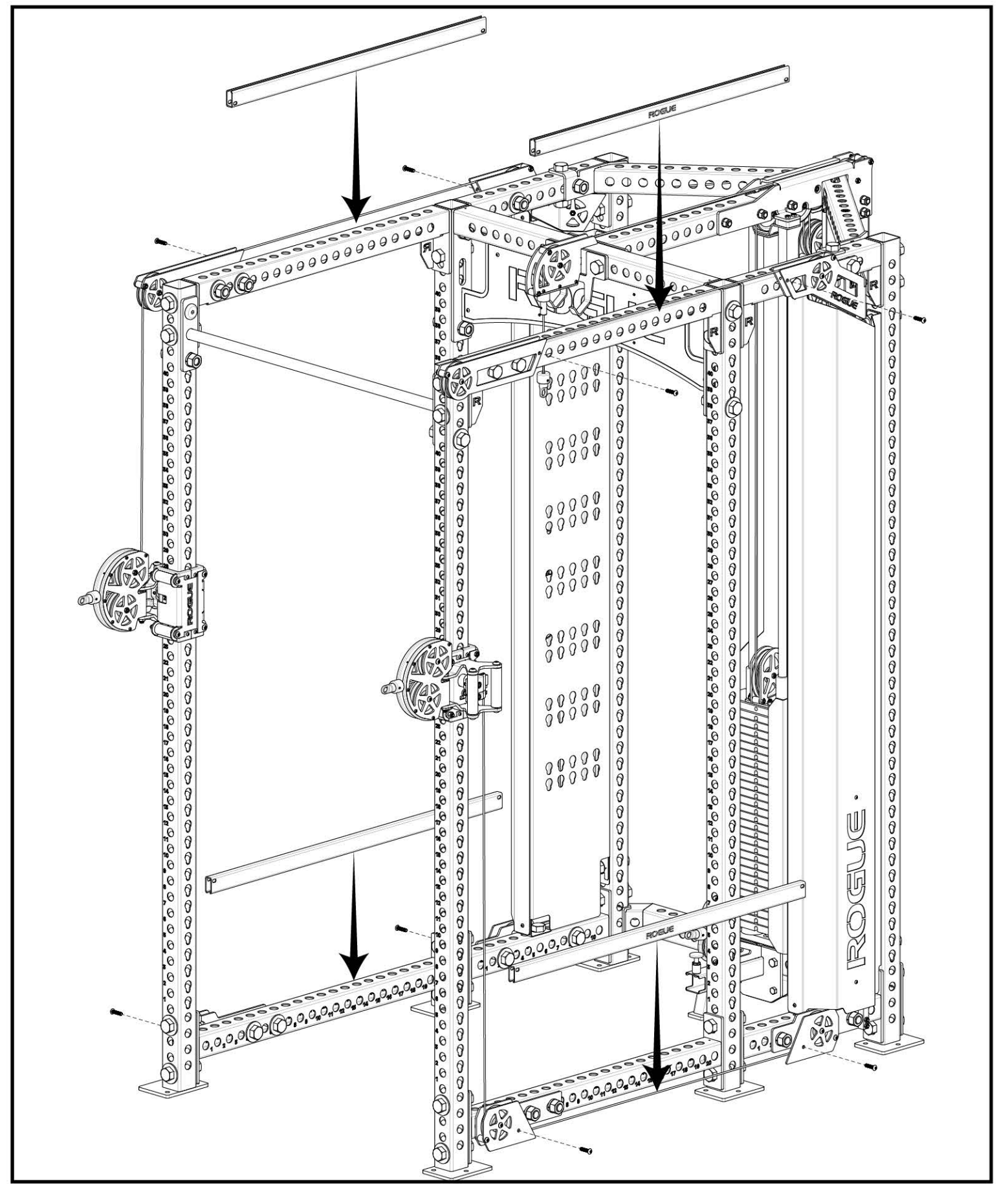

34-A

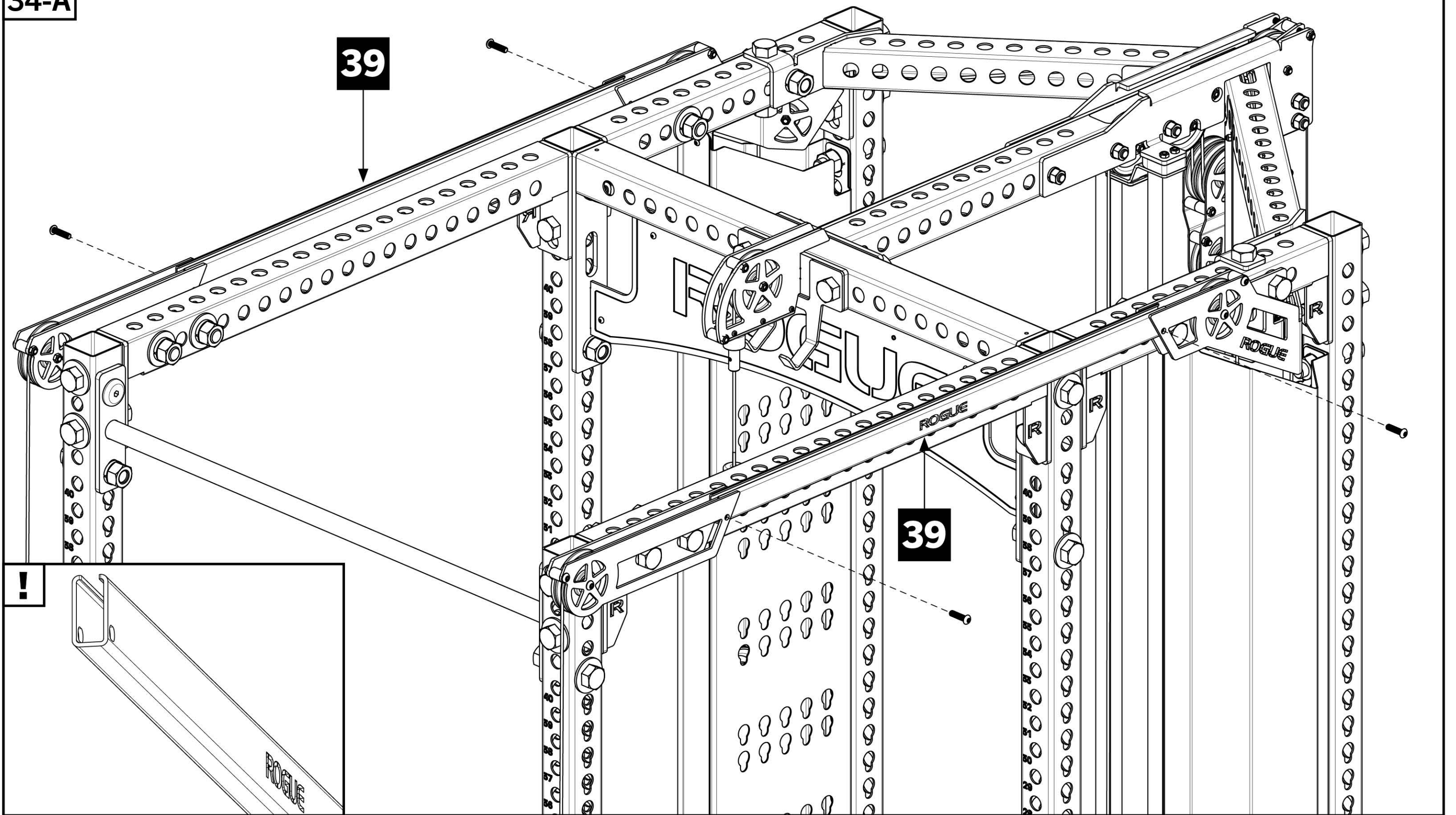

34-B

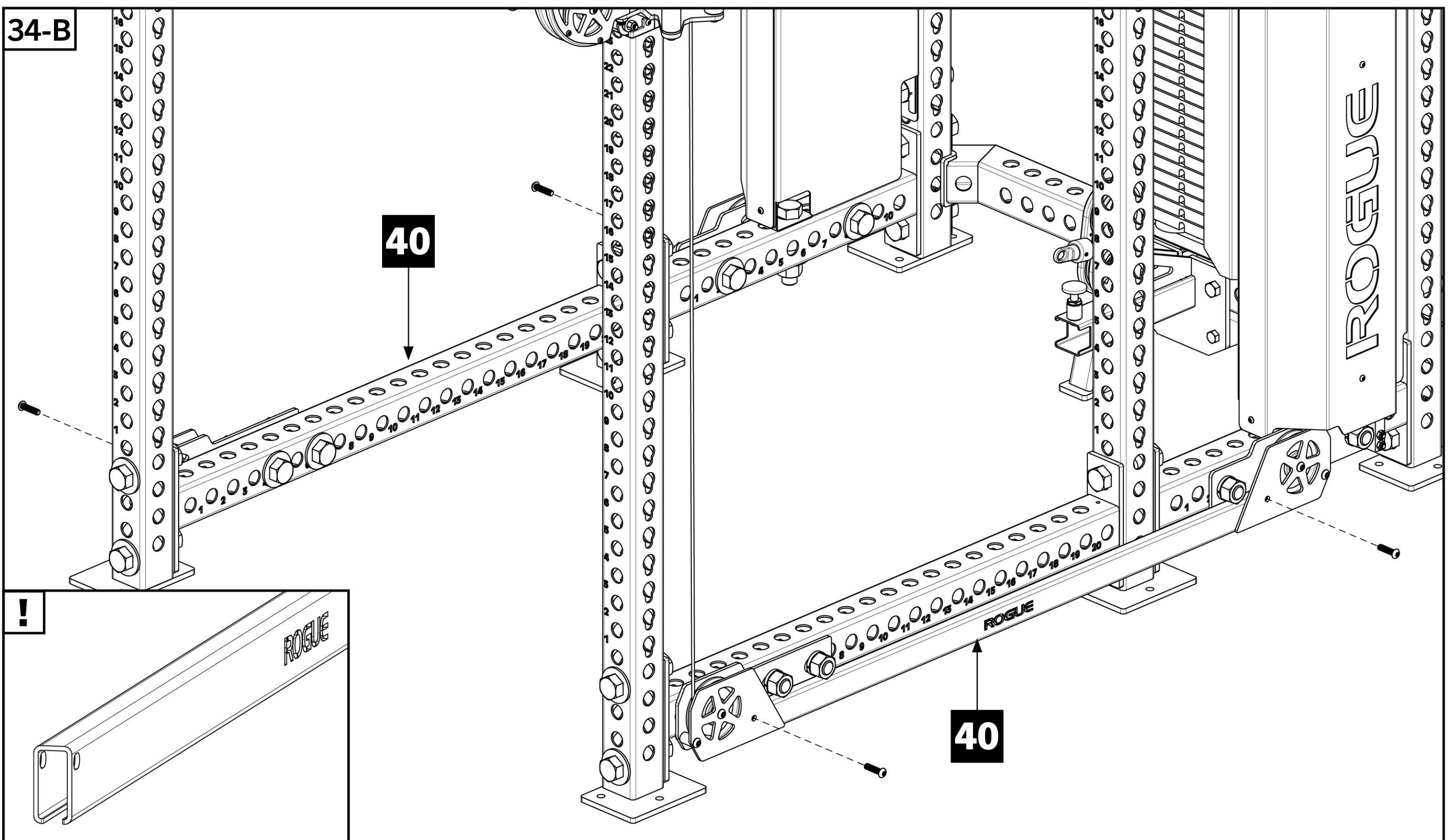

STEP 35

Tools Required:

- 1-1/2" Wrench, 1/8" Allen Key
- If modifying existing rack with add-on kit, skip to **35-B**.
- Place Key Washer over the Key Nut on the Plate Storage Post shown in **Detail** view.
- Assemble Plate Storage Pins [8] on rear Monster Uprights at desired hole heights.
- Slide Plate Storage Spacers [57] all the way down Plate Storage Pins with the set screws oriented on the bottom of Spacers as shown in **35-C**.
- Fully tighten set screws using 1/8" Allen Key.

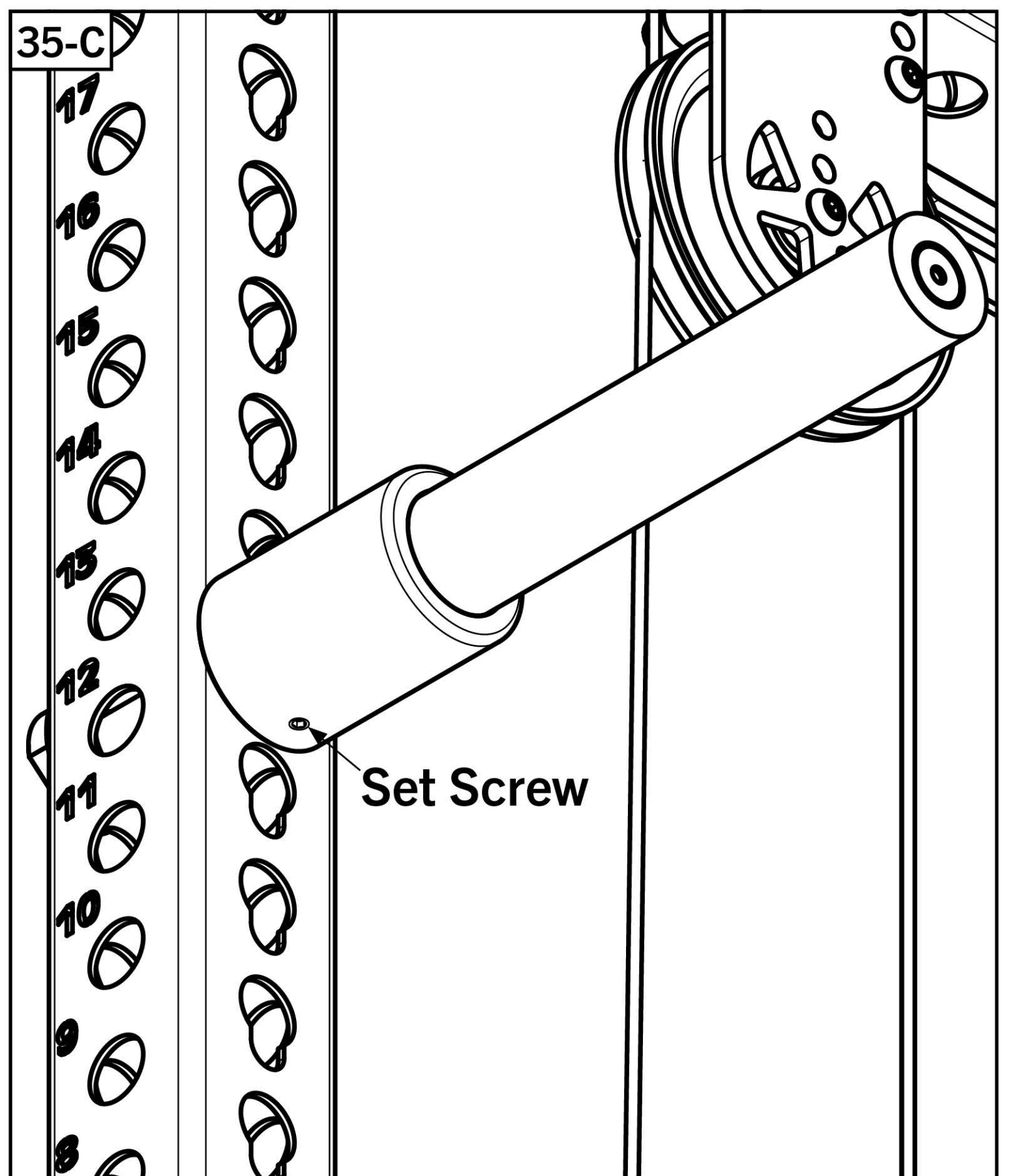
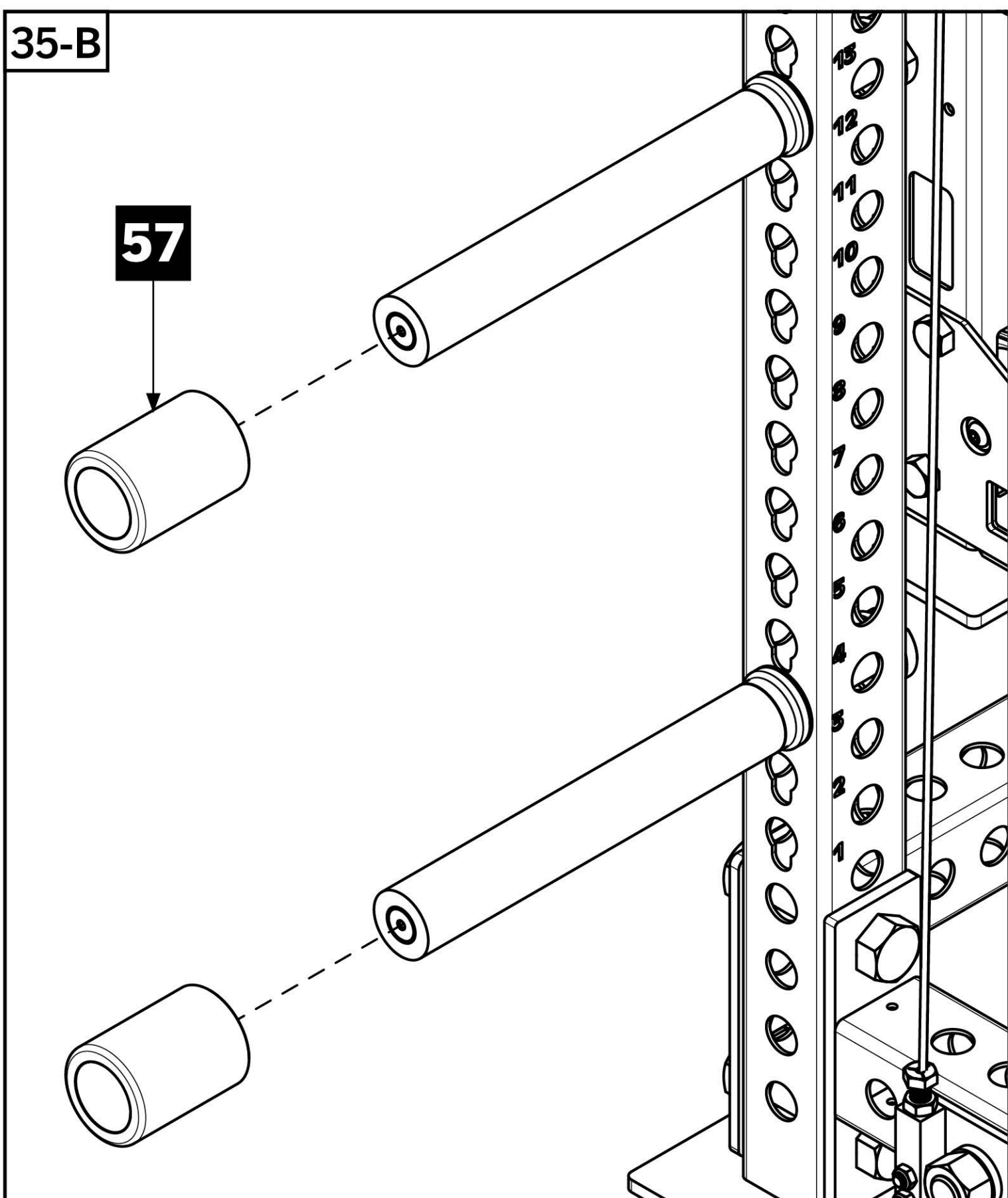
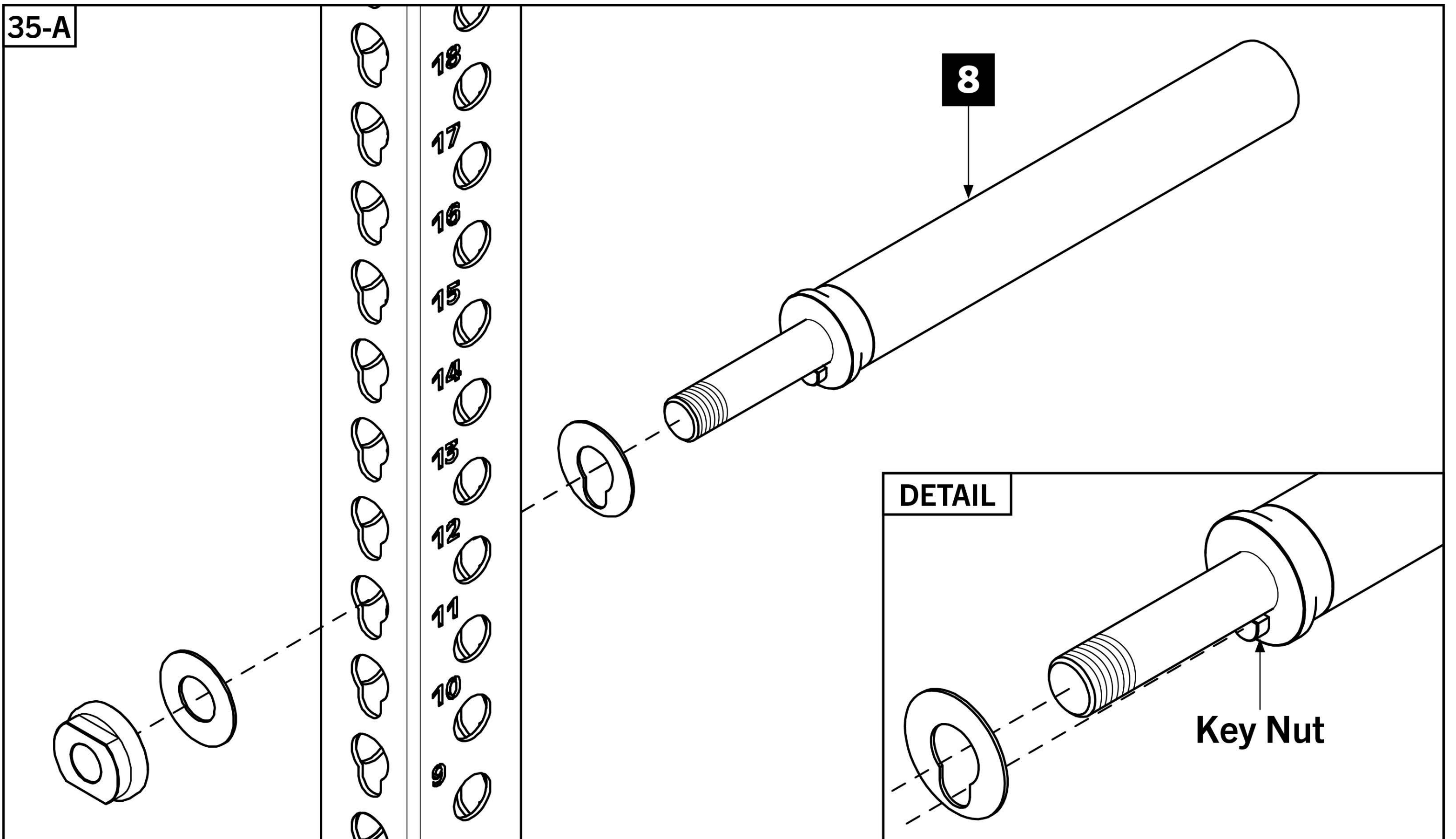
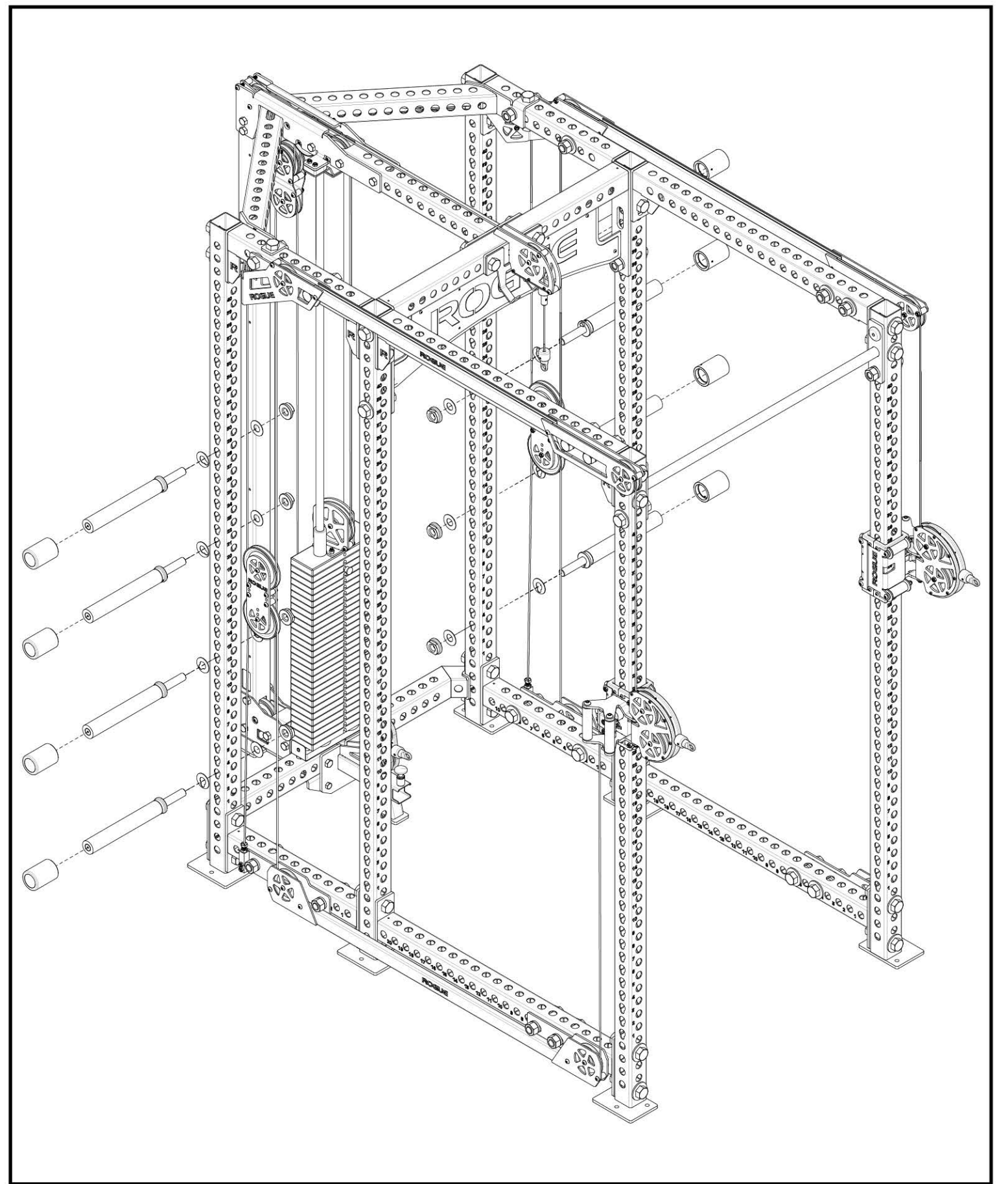

STEP 36

Tools Required:

- All
- Tighten ALL loose hardware on the entire rack.
- Starting with no weight selected on the Weight Stack, check cables by pulling on each clevis.

- If cables are too tight or loose, adjust accordingly by loosening or tightening the lower 1/2" Jam Nuts on Low Side Cables [55].

36-A

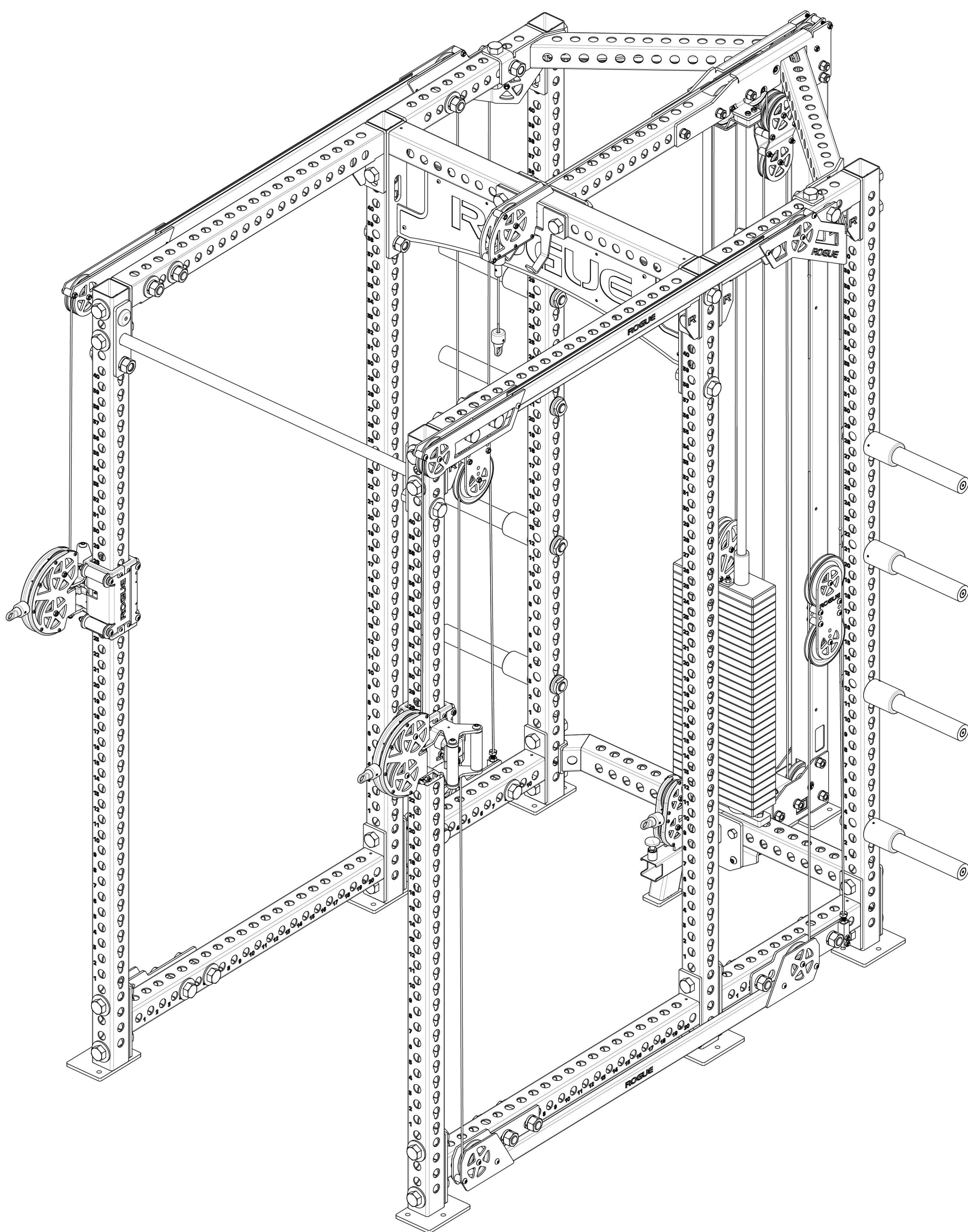

STEP 37

- Apply the Weight Stack Number Labels [56] on the front of the Weight Stack Plates, approximately 3.5" from the edge of plate.
- Attach key ring on Selector Pin Lanyard [34] to front hole on pulley plate of the Weight Stack Stem [32].

- Attach Single Handle Attachments [60] to Swivel Trolleys using included Carabiners.
- Attach Lat Bar [58] to Lat Pull down clevis attachment point.
- Re-insert the Footplate into Low Row Footplate Assembly [28] and attach Standard Grip Triangle [59] to clevis.

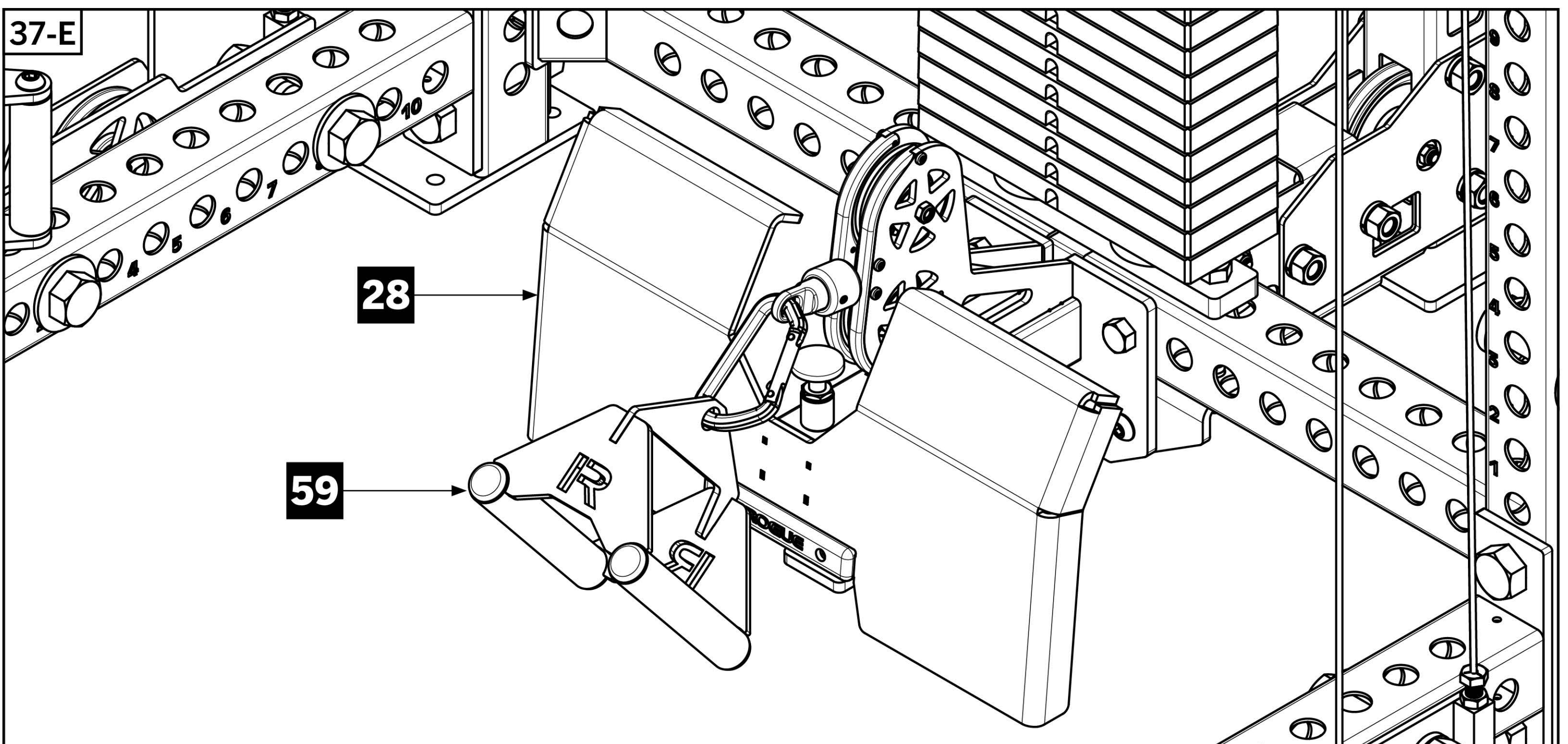
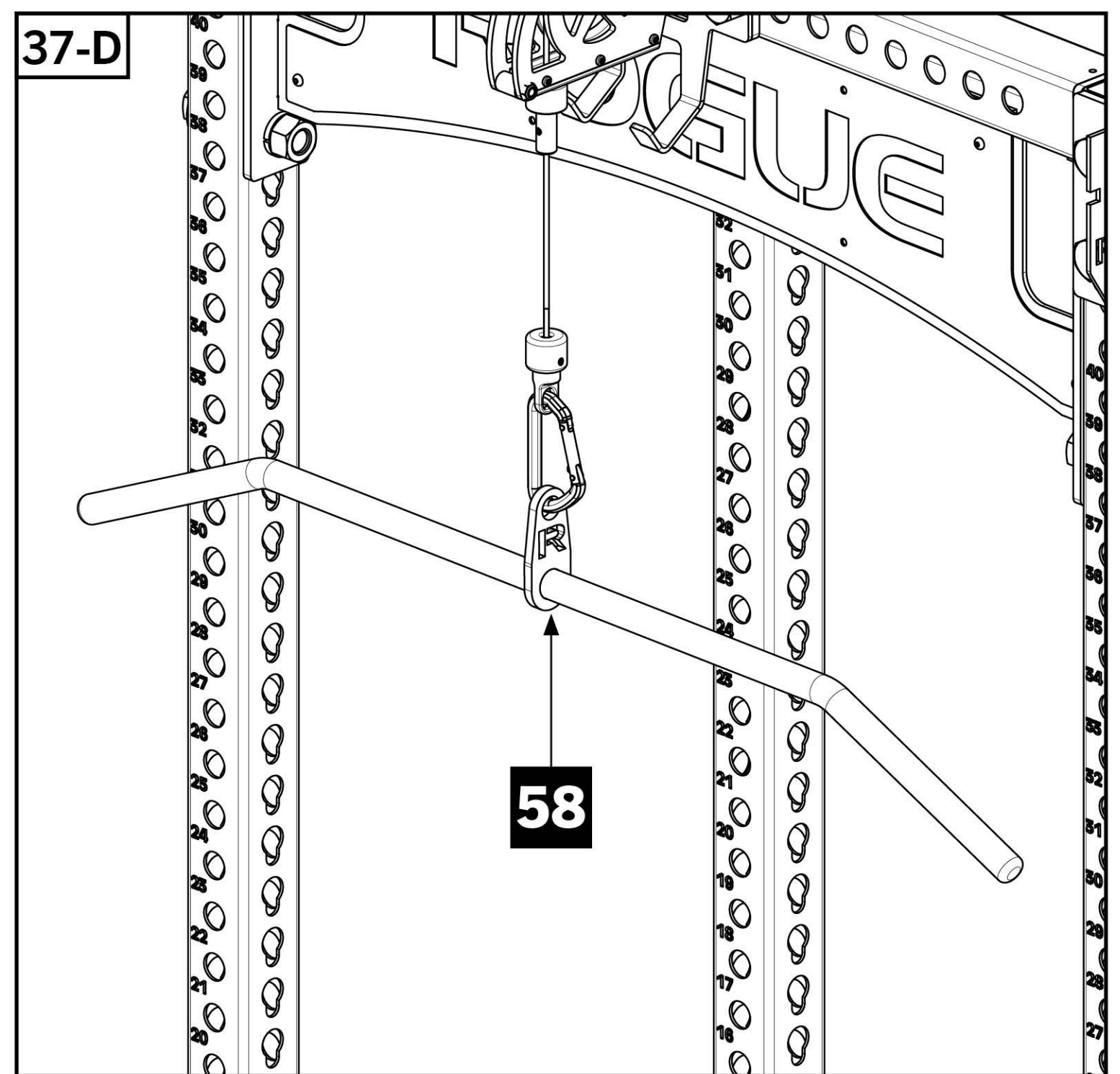
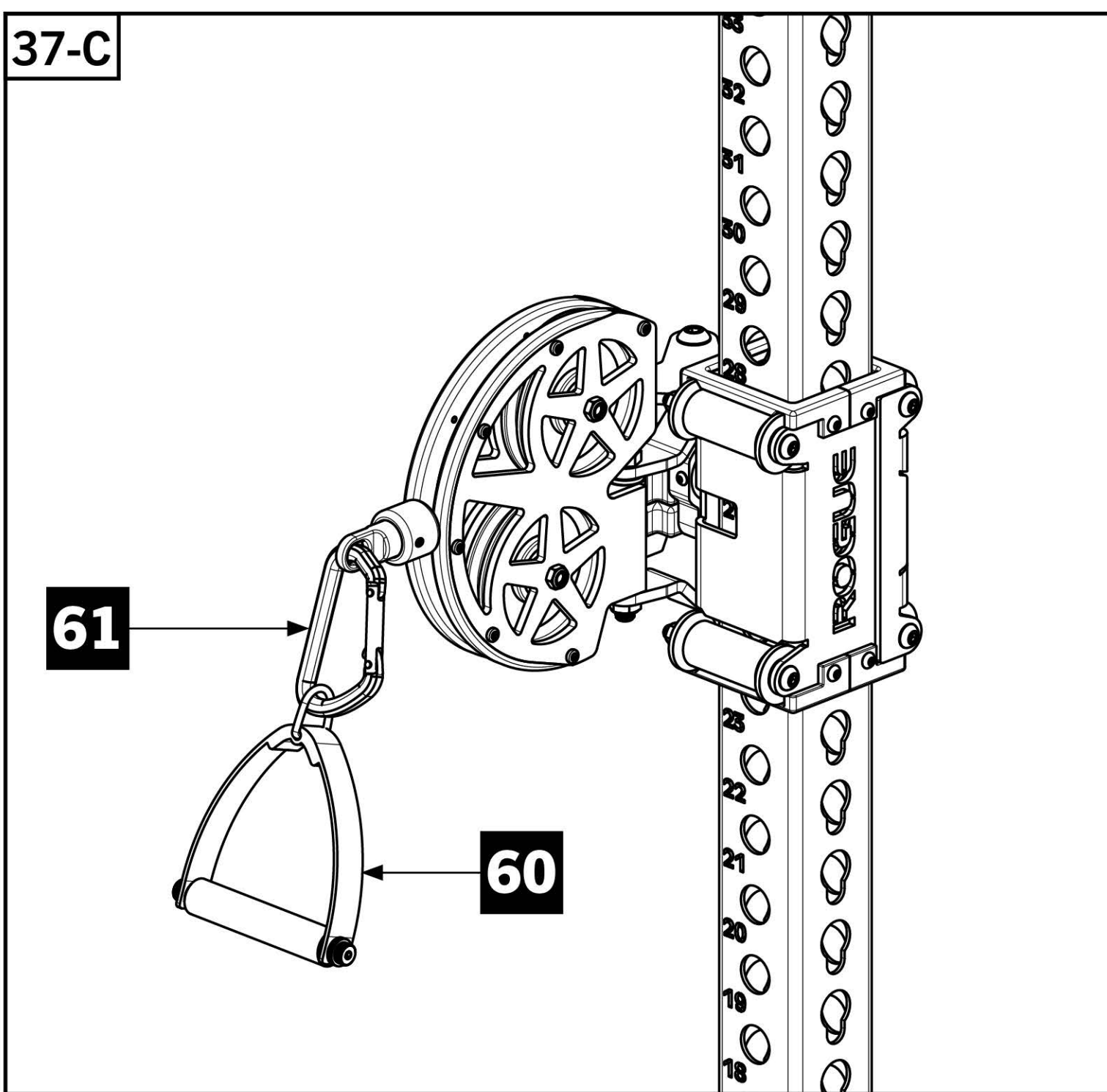
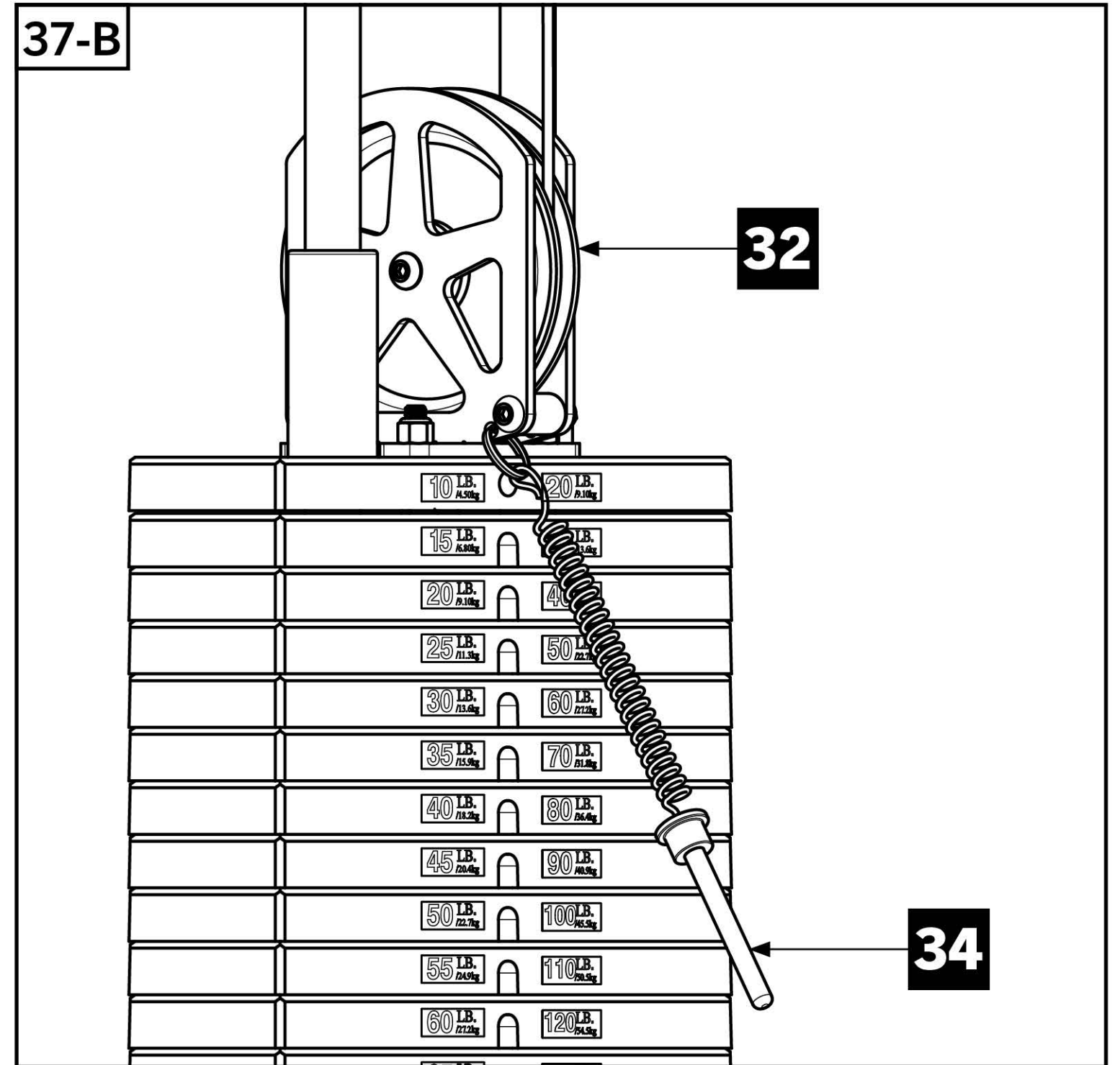
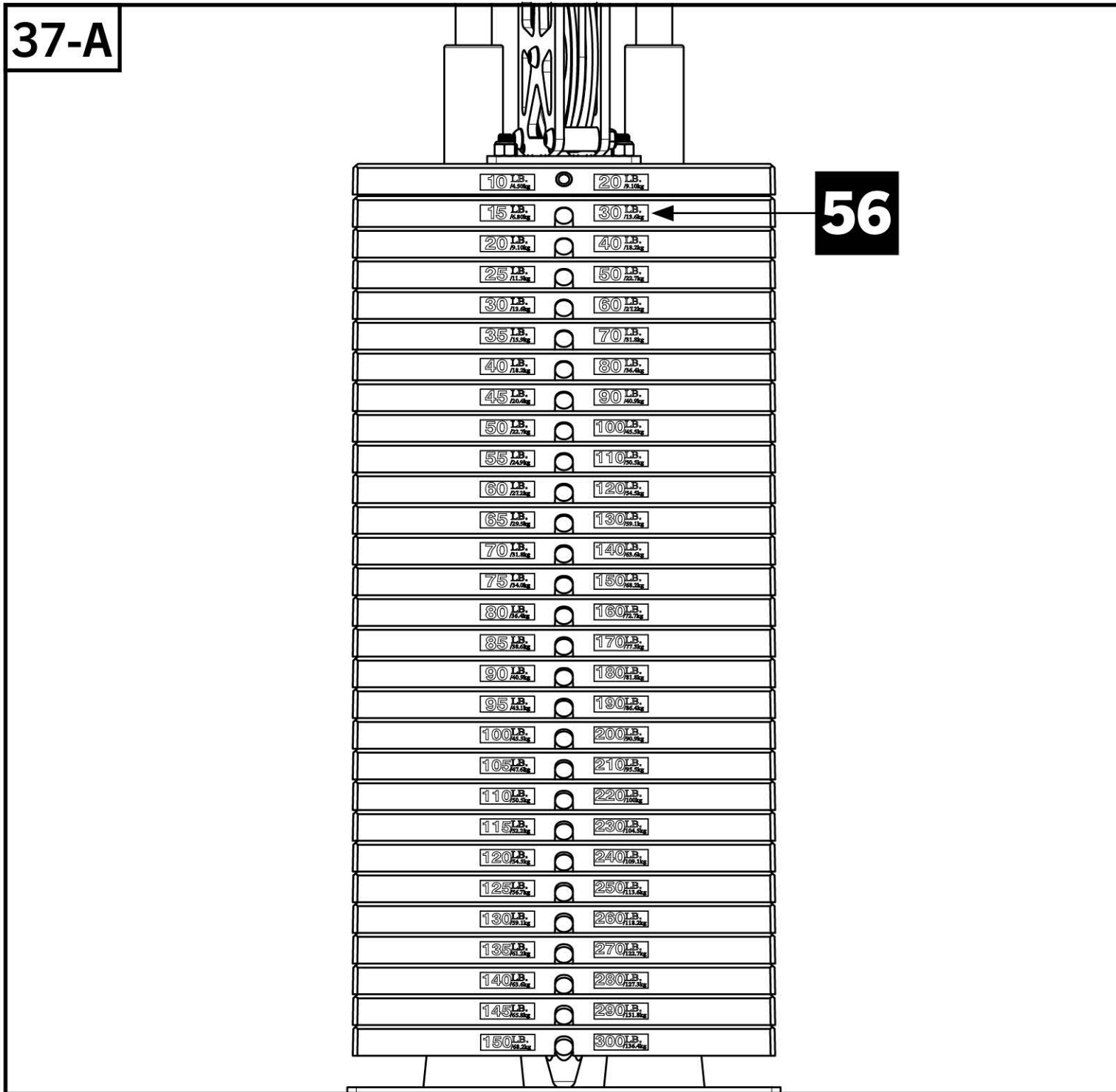

STEP 38 (SHROUD ASSEMBLY)

- Align Weight Stack Shroud RH [80] and Weight Stack Shroud LH [81] with corresponding holes on Rear 3X3 Upright [17] and bolt Shrouds to Upright using 1/4" x 3-1/2" Button Head Screws [93] and 1/4" Nylock Nuts [95].
- Align top holes on Shrouds to the front side of Top Rear Angle Crossmembers and bolt together using 1/4" x 3-1/2" Button Head Screws and 1/4" Nylock Nuts.
- Align and bolt the bottom holes on Shrouds to the corresponding holes on Weight Stack Shroud Bottom Bracket [82] using 1/4" x 5/8" Button Head Screws [94].

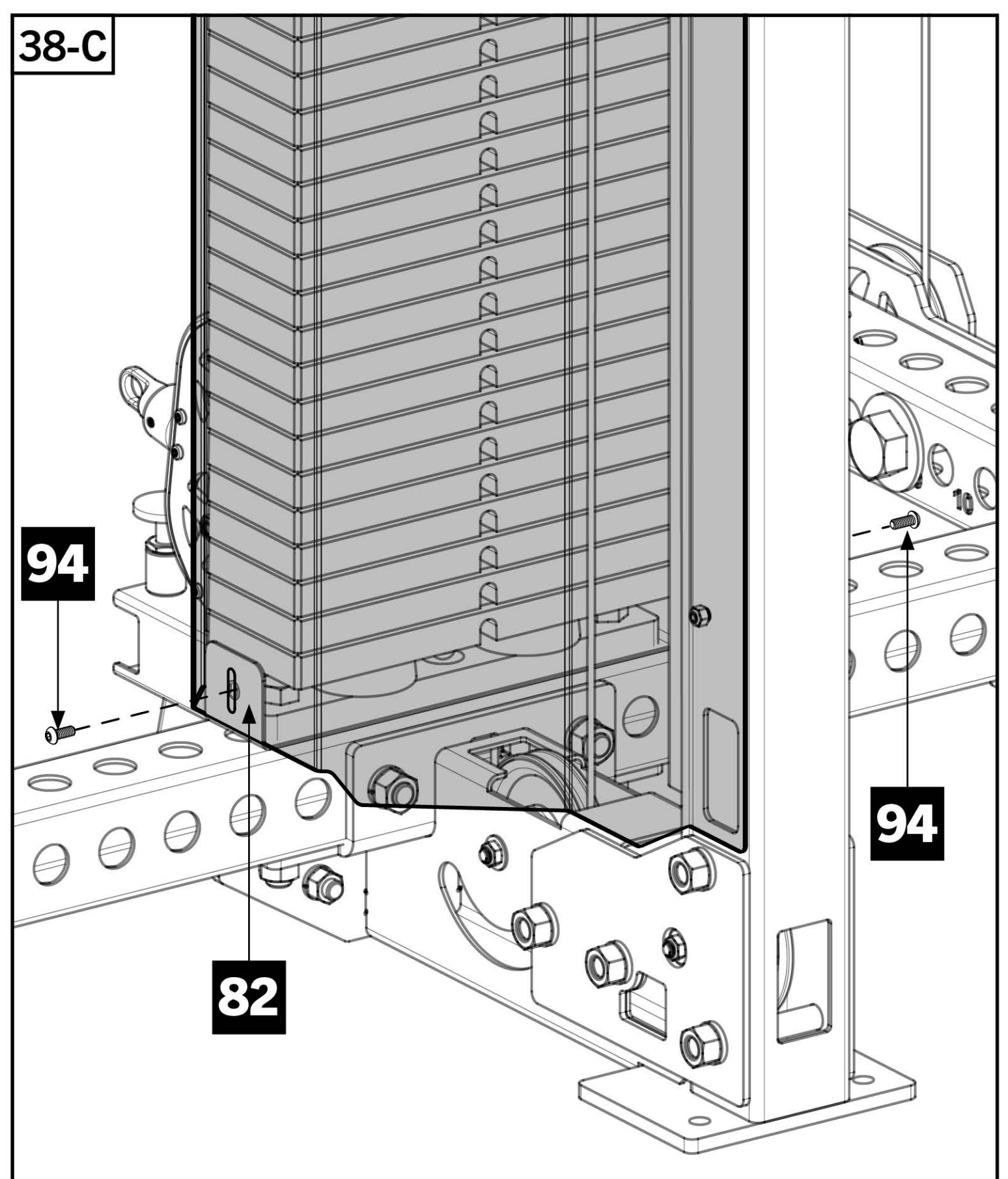
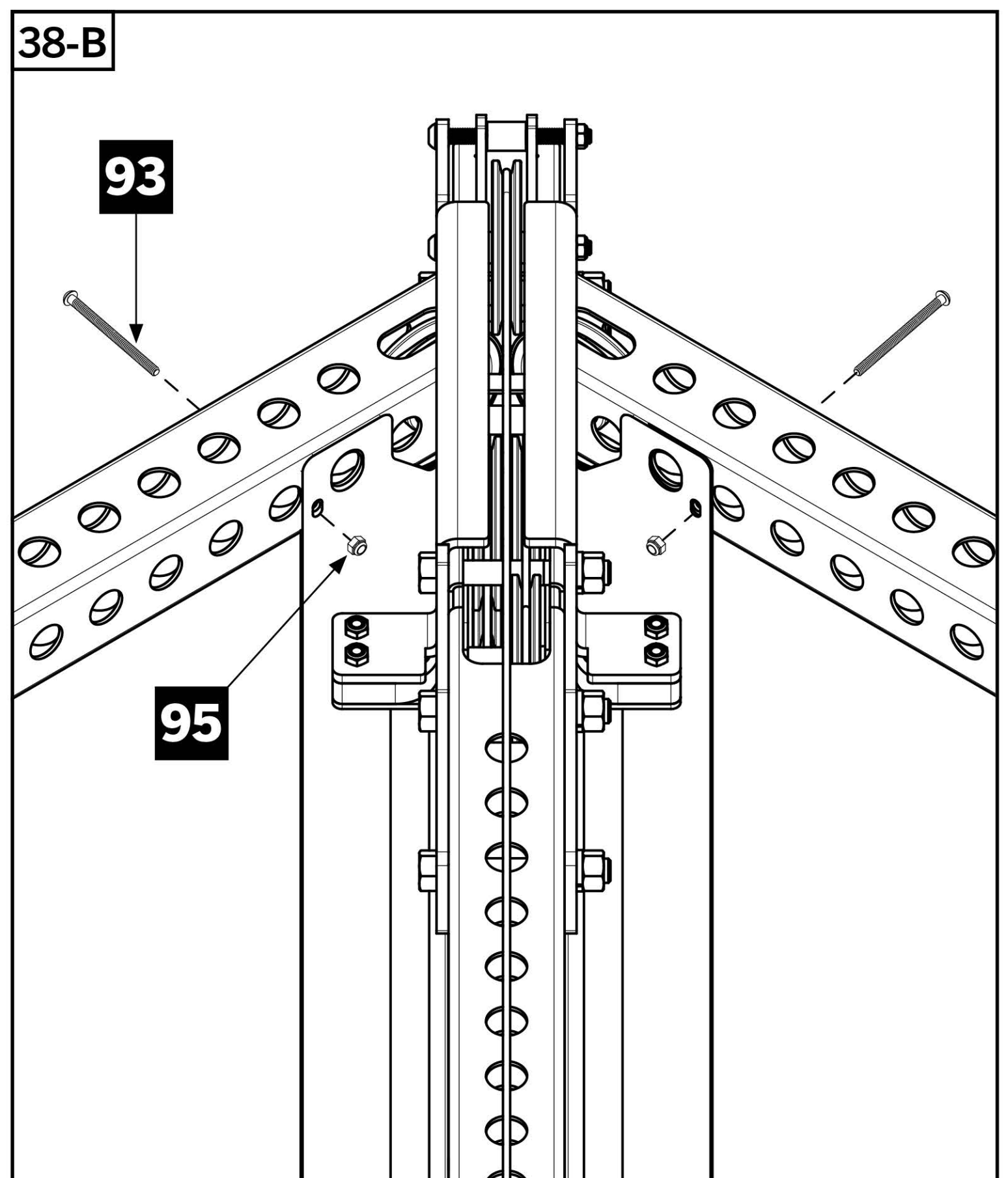
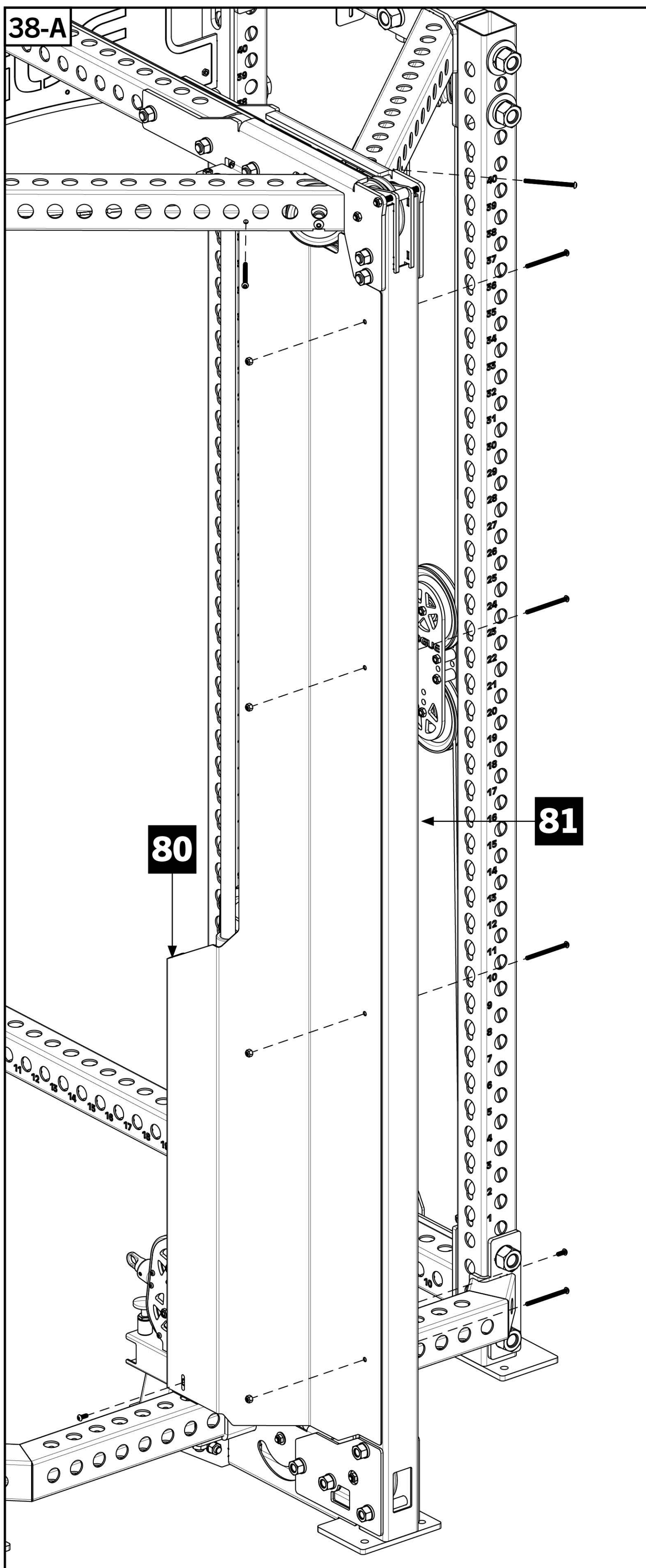
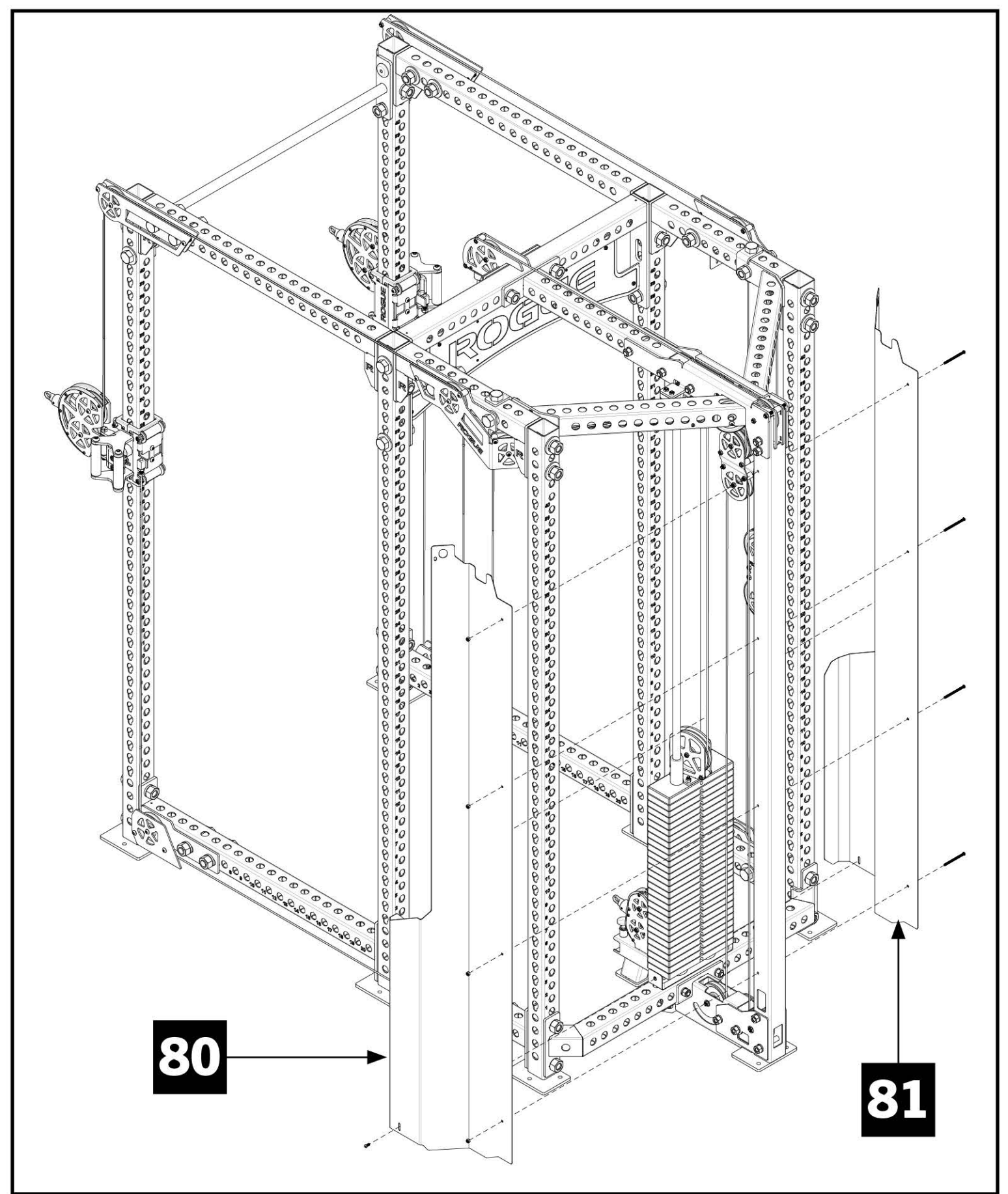

STEP 39 (SHROUD ASSEMBLY)

- Align the 6" Foam Panel [98] to the middle panel of the Side Shroud - RH [83] centering it between all sides. Peel off the adhesive backing and stick the 6" Foam to the middle panel.
- Place the 3" Foam Panels [97] on panels to the left and right of the center of the Side Shroud - RH [83]. Peel off the adhesive backing and stick the foam to the correct panels shown in **39-B** and **39-C**.
- Repeat the whole process for the Side Shroud - LH [84].

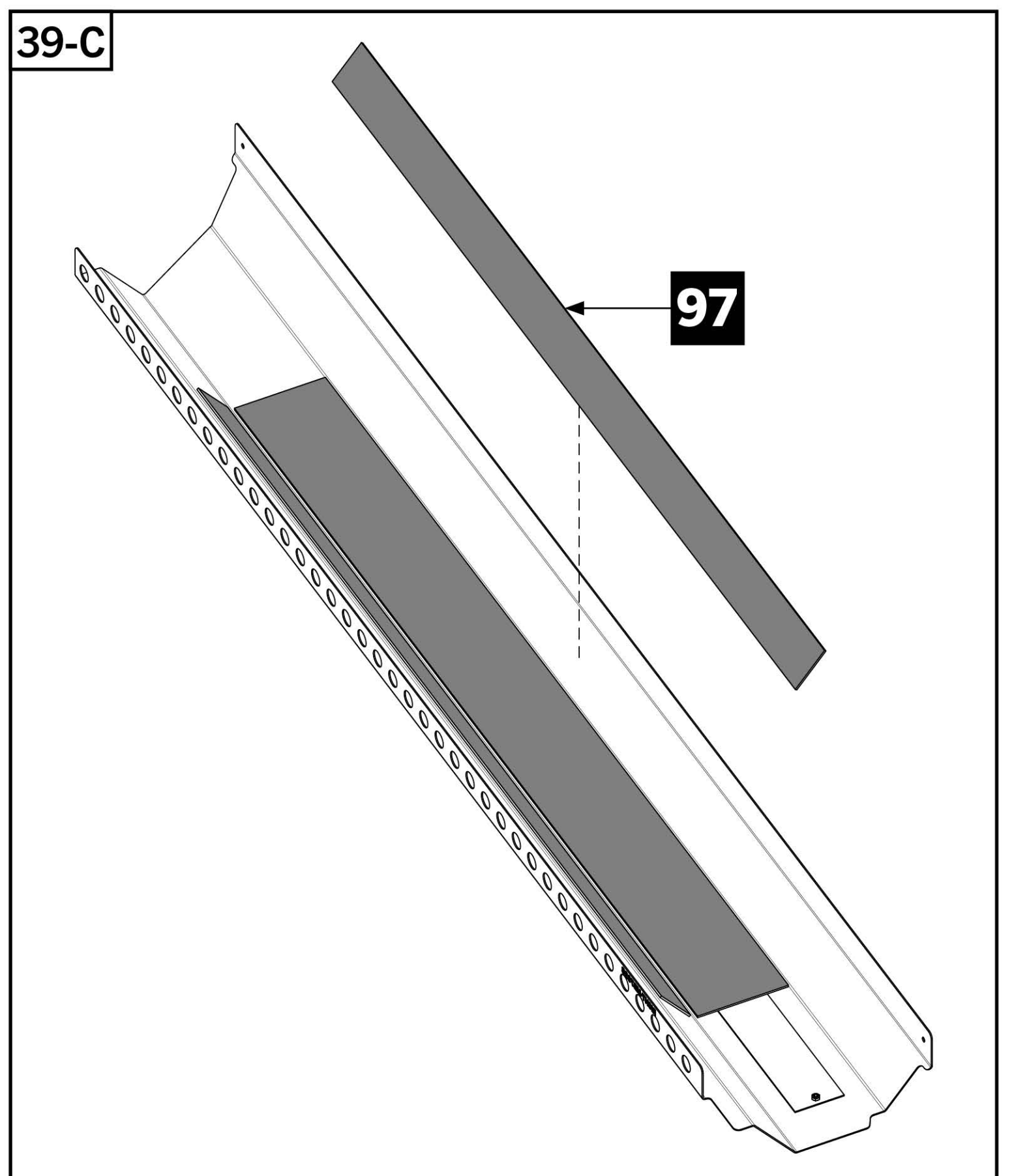
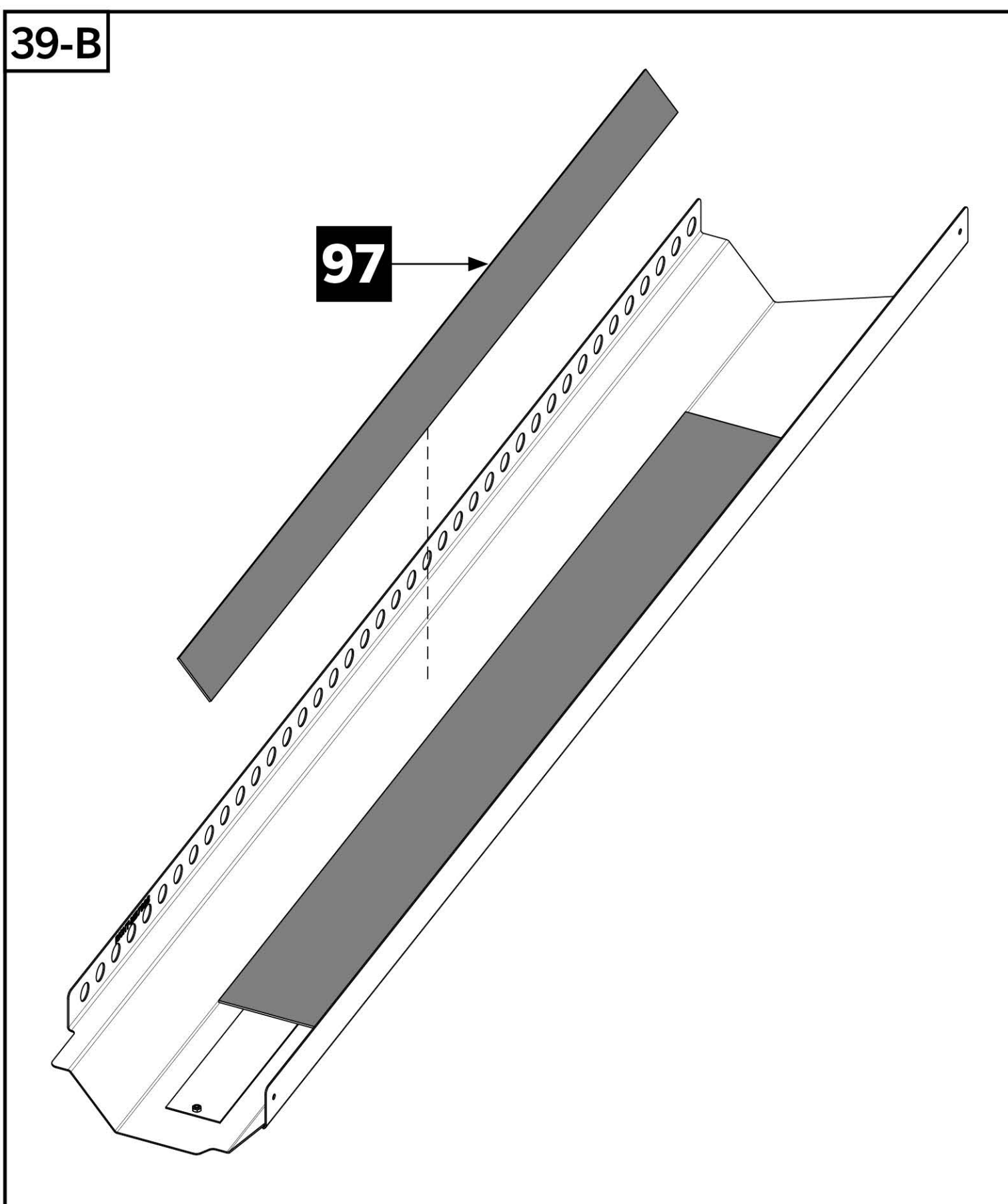
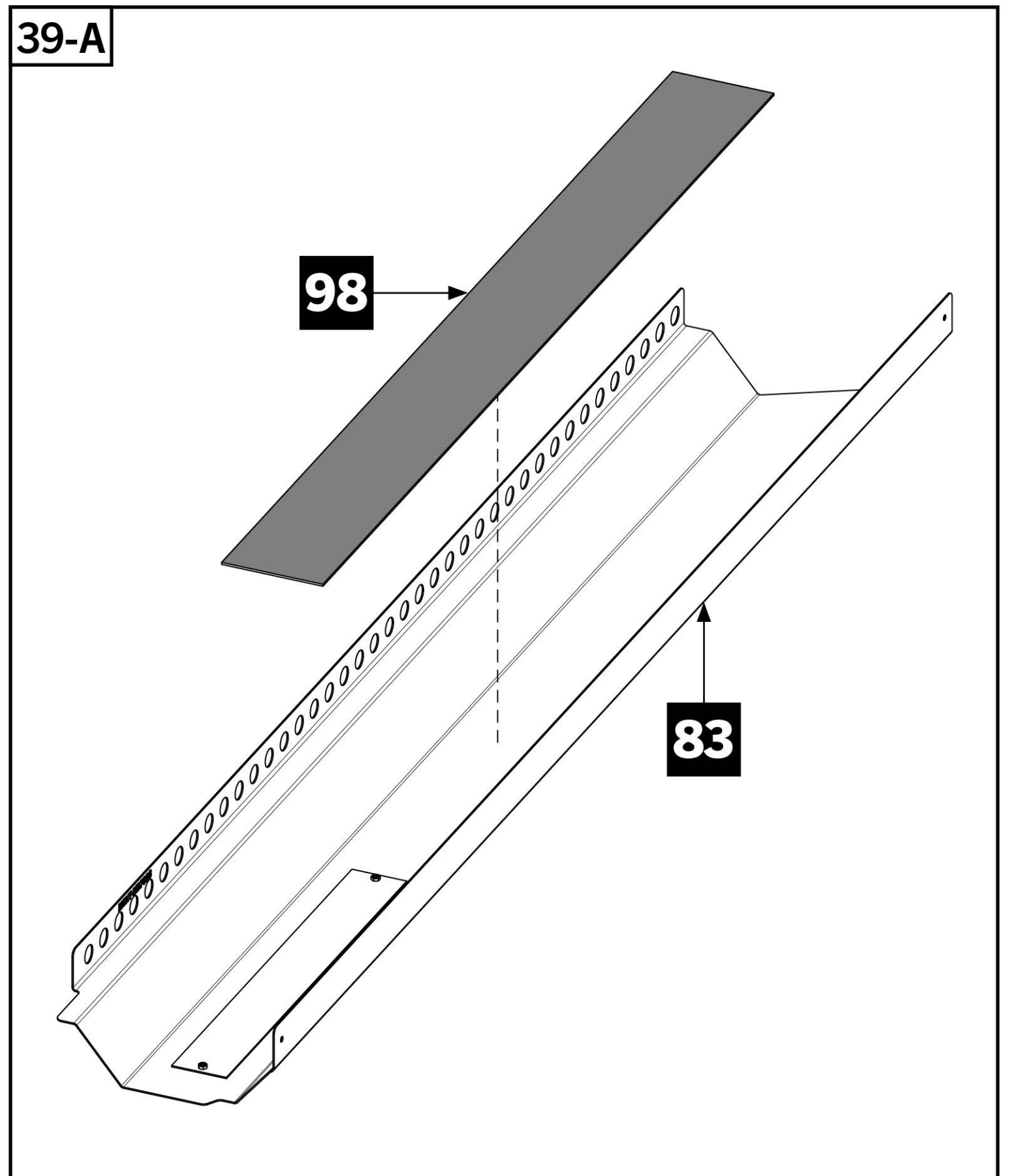
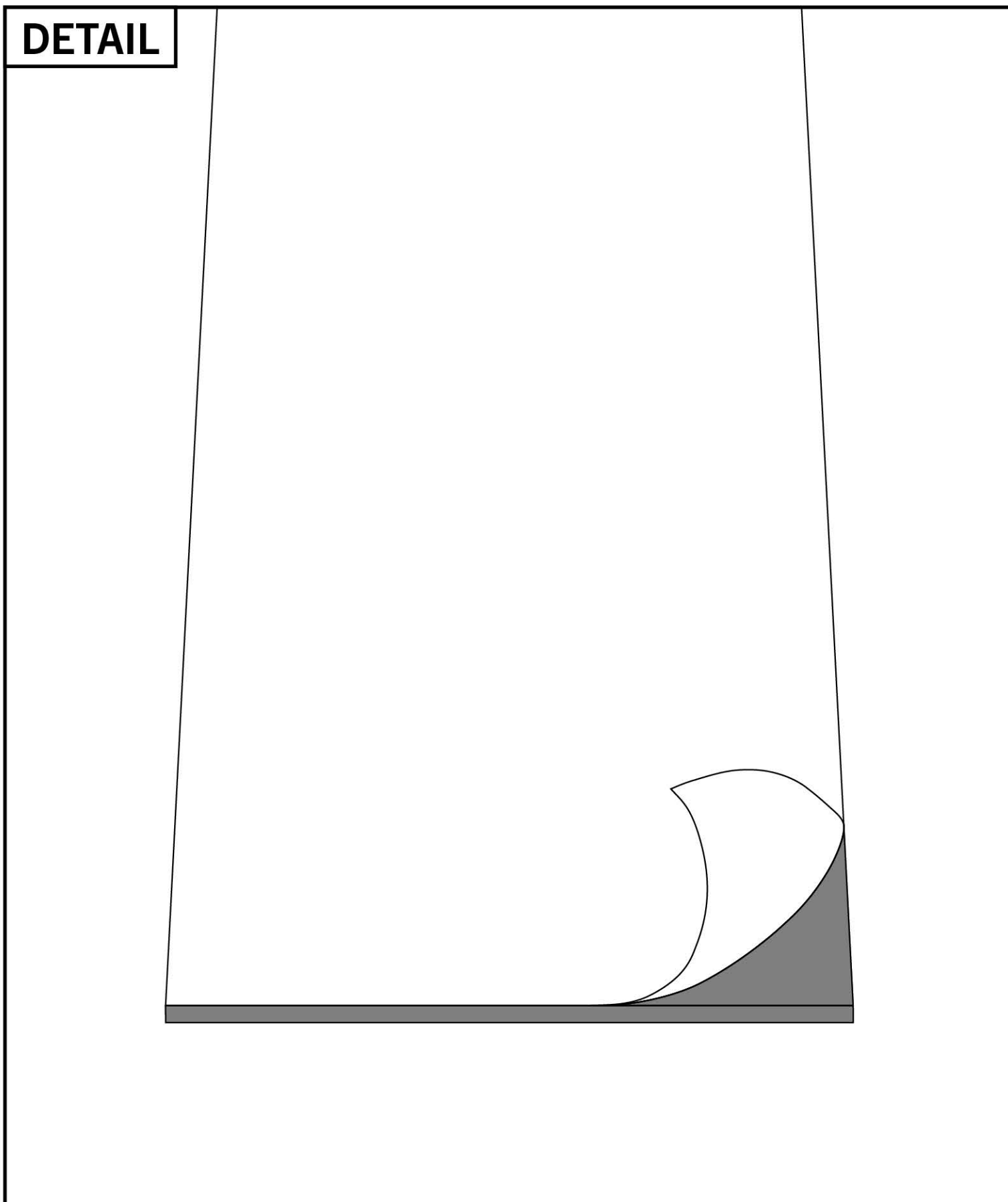
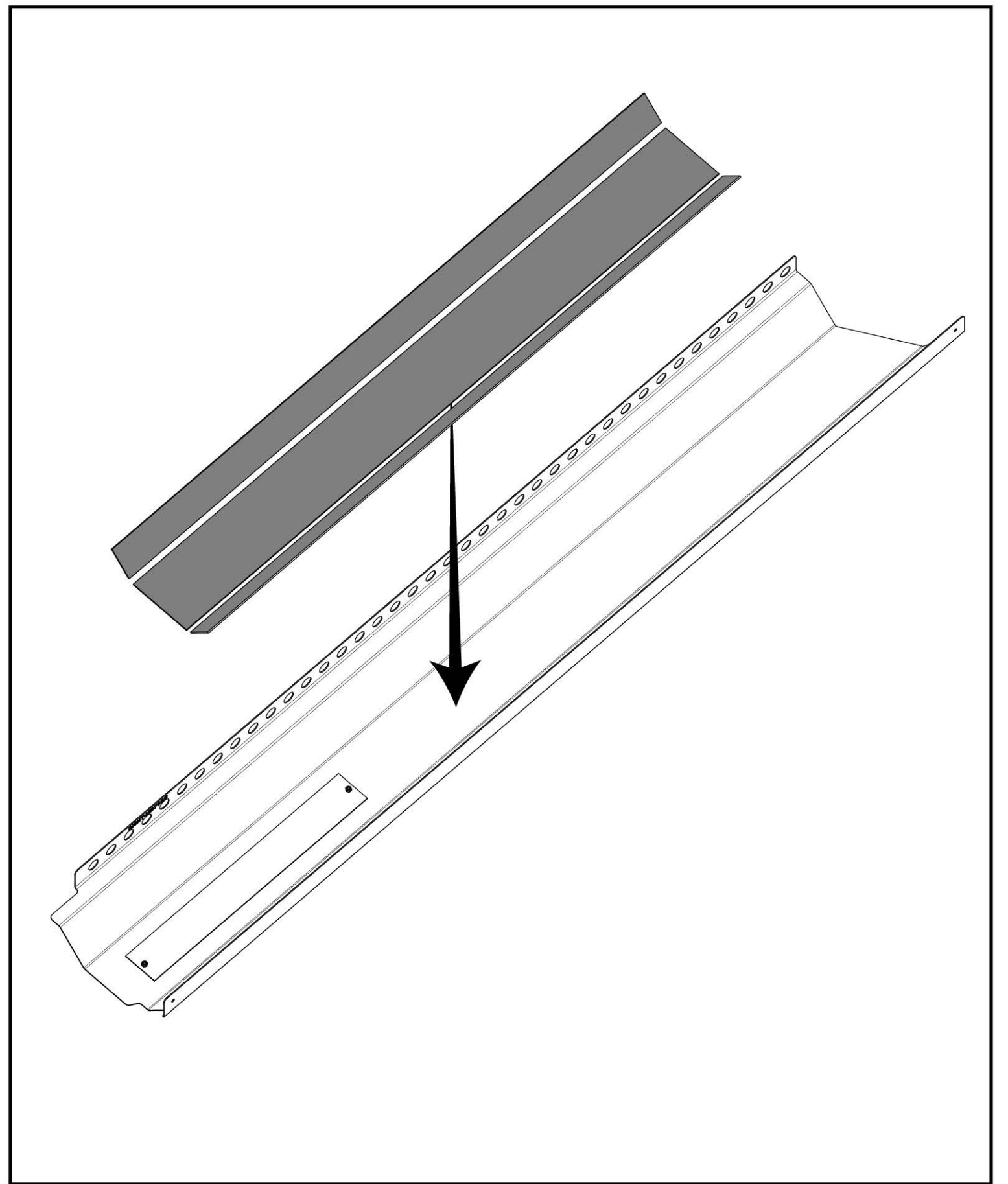

STEP 40 (SHROUD ASSEMBLY)

- Bolt Side Shroud Bottom Brackets [88] vertically to 24" Rear Low Crossmember [5] in locations shown using 1" x 4-3/4" Hex Bolts [89], 1" Flat Washers [90], 1" Lock Washers [91], and 1" Hex Nuts [92].
- Assemble Side Shroud -RH [83] and -LH [84] on rear uprights of rack using included 1" hardware through the highest and lowest 1" holes on Side Shrouds.

Note:

- Leave the 1" Hex Nuts shown in 40-B and 40-C very loose until Storage Panels are assembled on the next step.

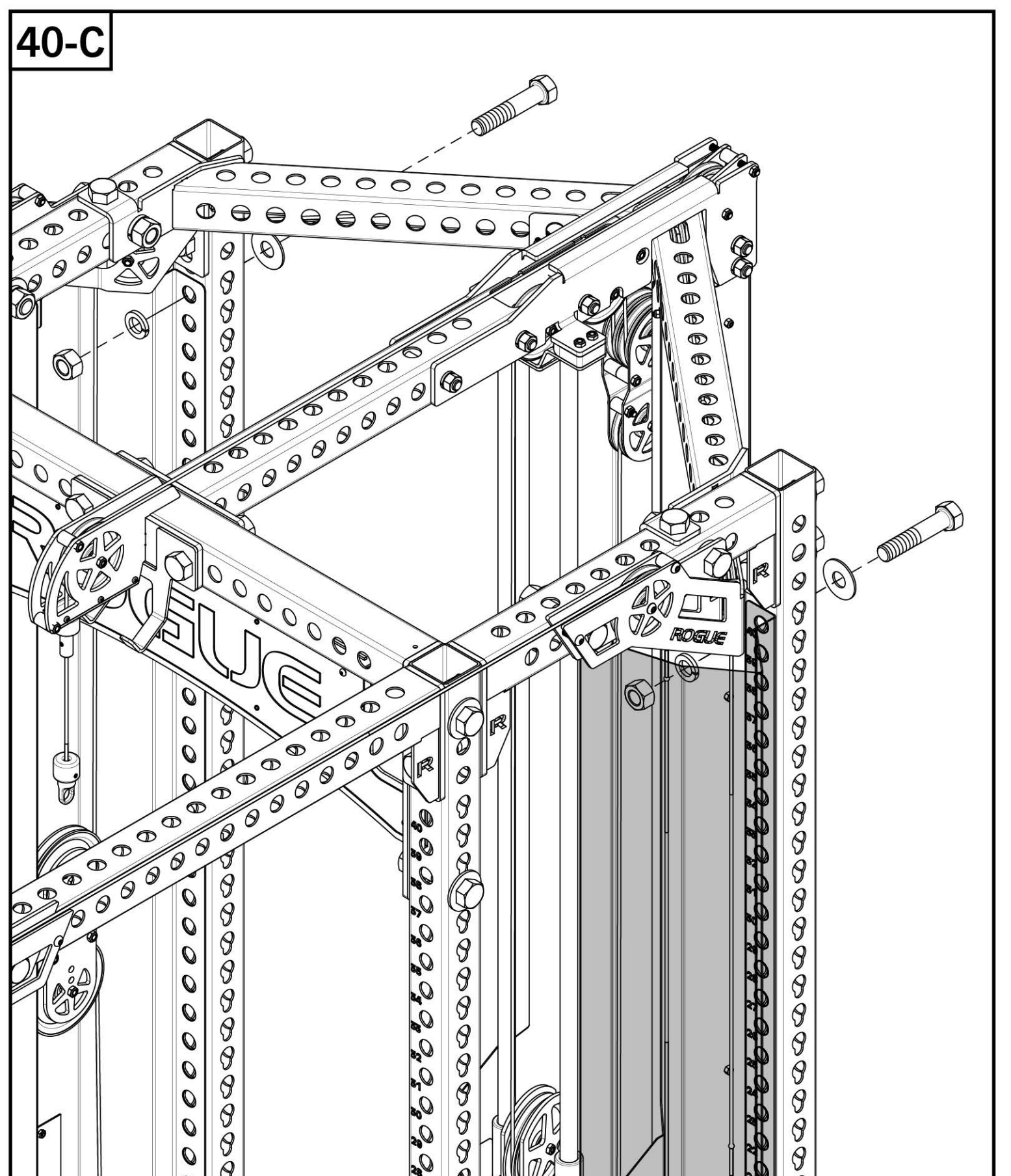
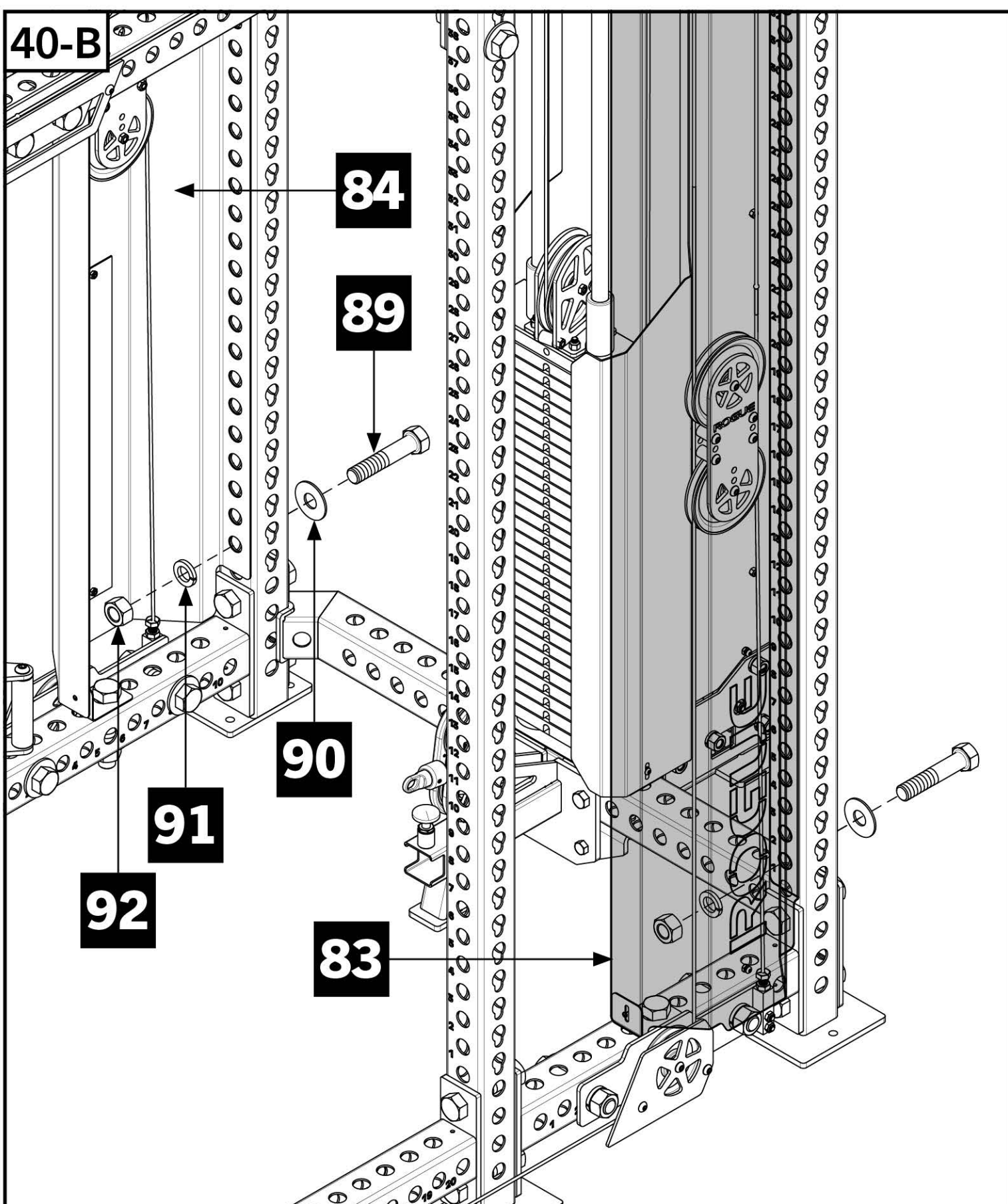
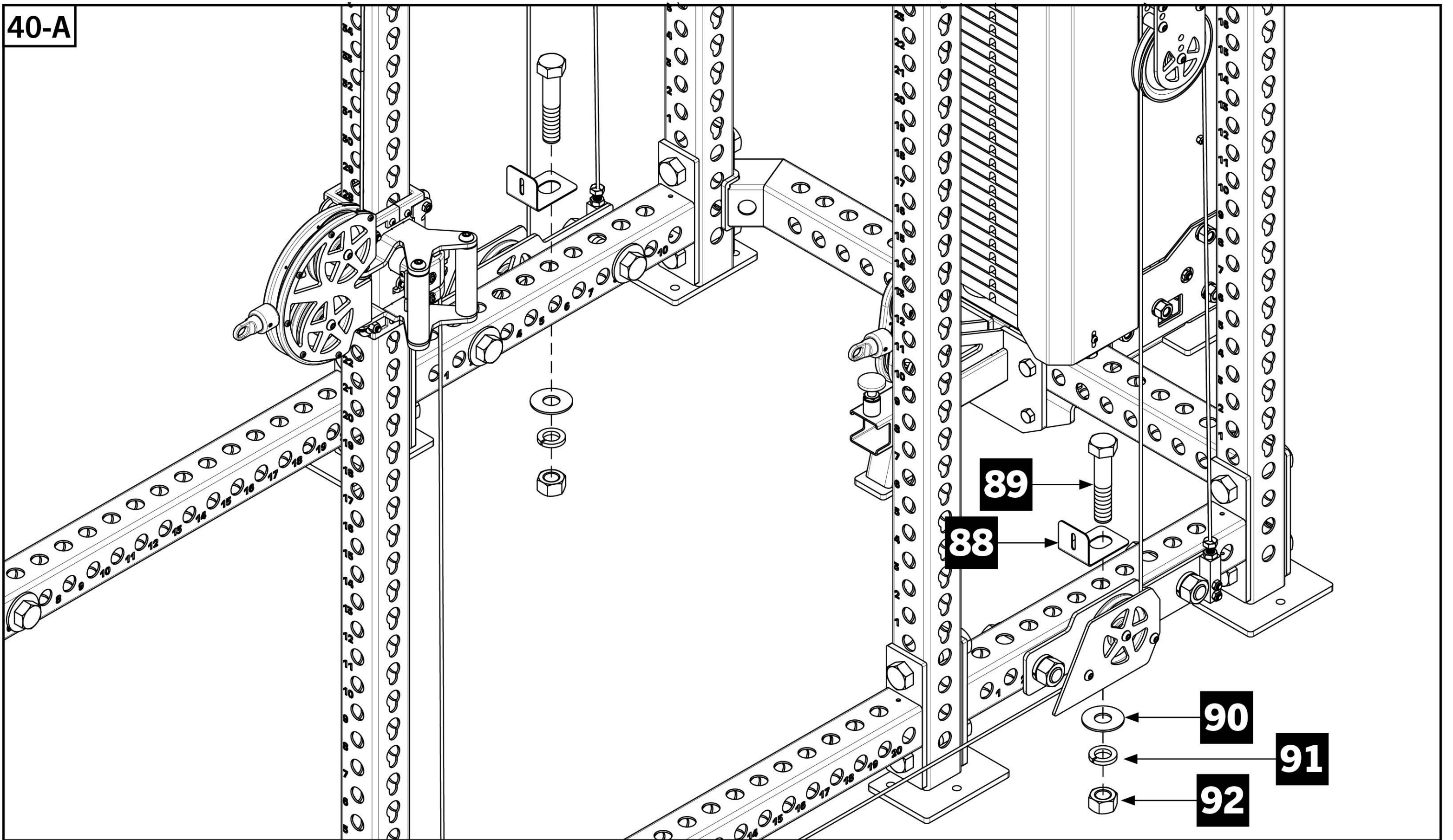
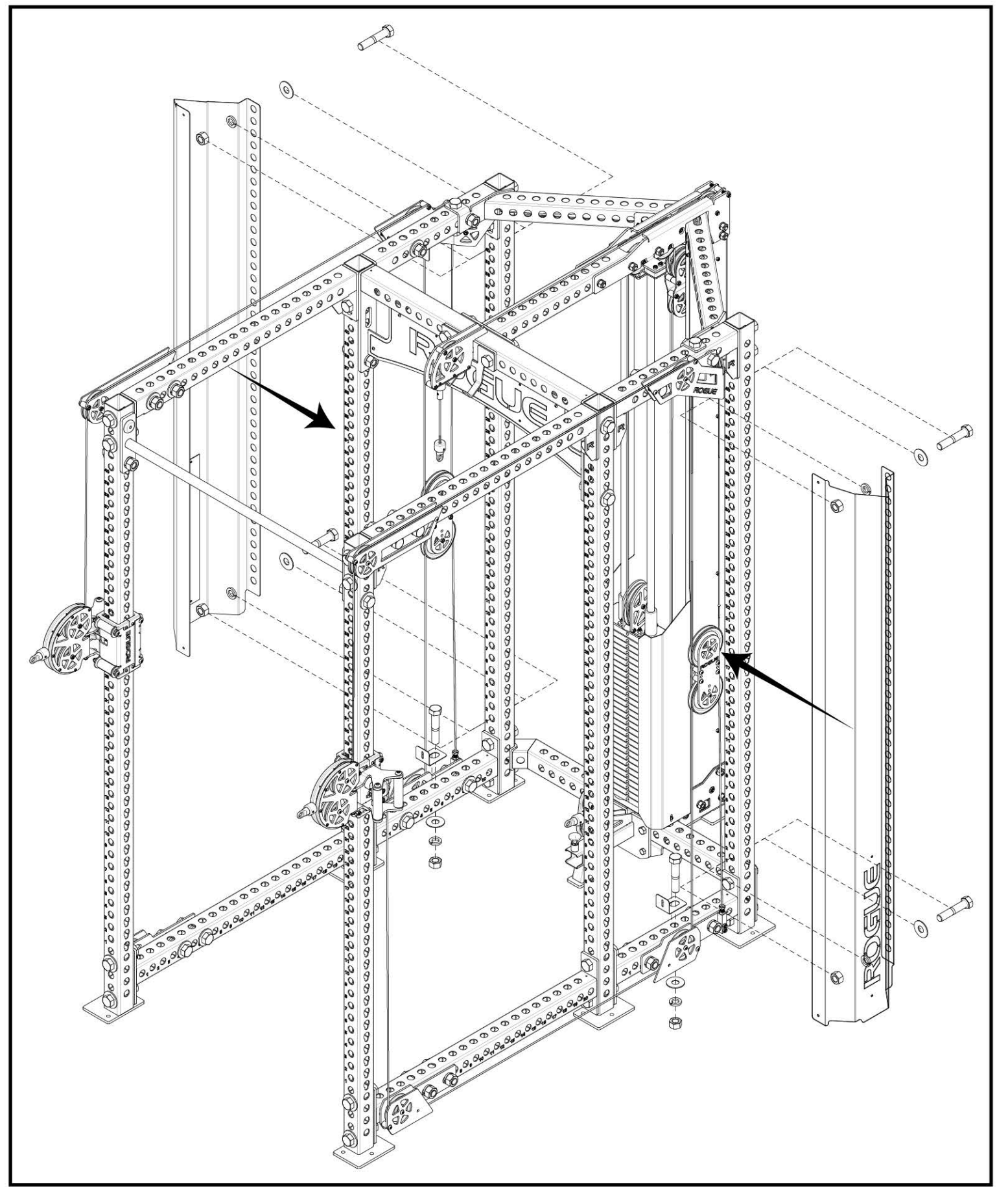

STEP 41 (SHROUD ASSEMBLY)

Tools Required:

- 1-1/2" Wrench, 5/32" Allen Key, 7/16" Wrench
- Attach rear top and bottom holes on Storage Panels [85],[86] to horizontal 1" hardware installed on previous step, and align 1/4" holes on front with 1/4" holes on Side Shrouds and Shroud Brackets.
- Bolt both Side Shrouds and Storage Panels to Bottom Brackets using four 1/4" x 5/8" Button Head Screws [94] and four 1/4" Thin Nylock Nuts [96].
- Fully tighten all Shroud Kit hardware.

Note:

- Only the LH Storage Panel shown below. Repeat steps below to assemble the RH Storage Panel onto Side Shroud RH.

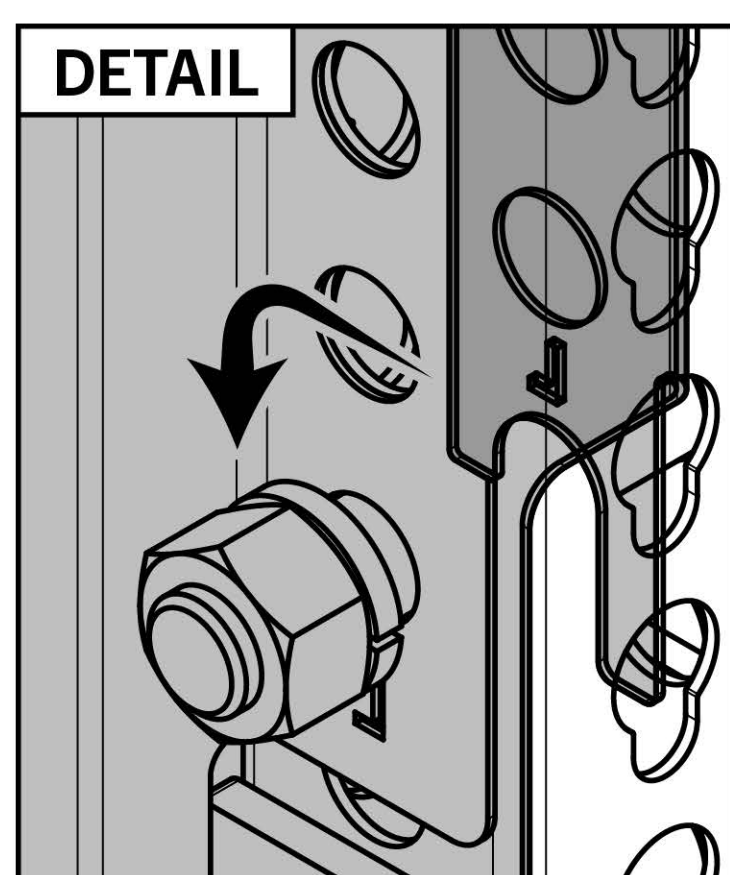
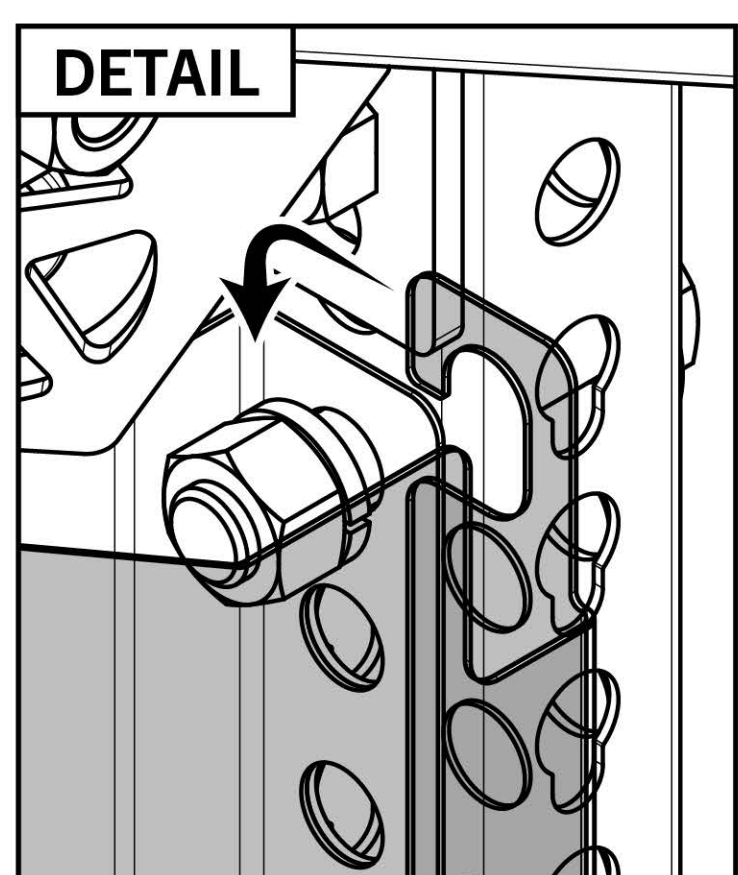
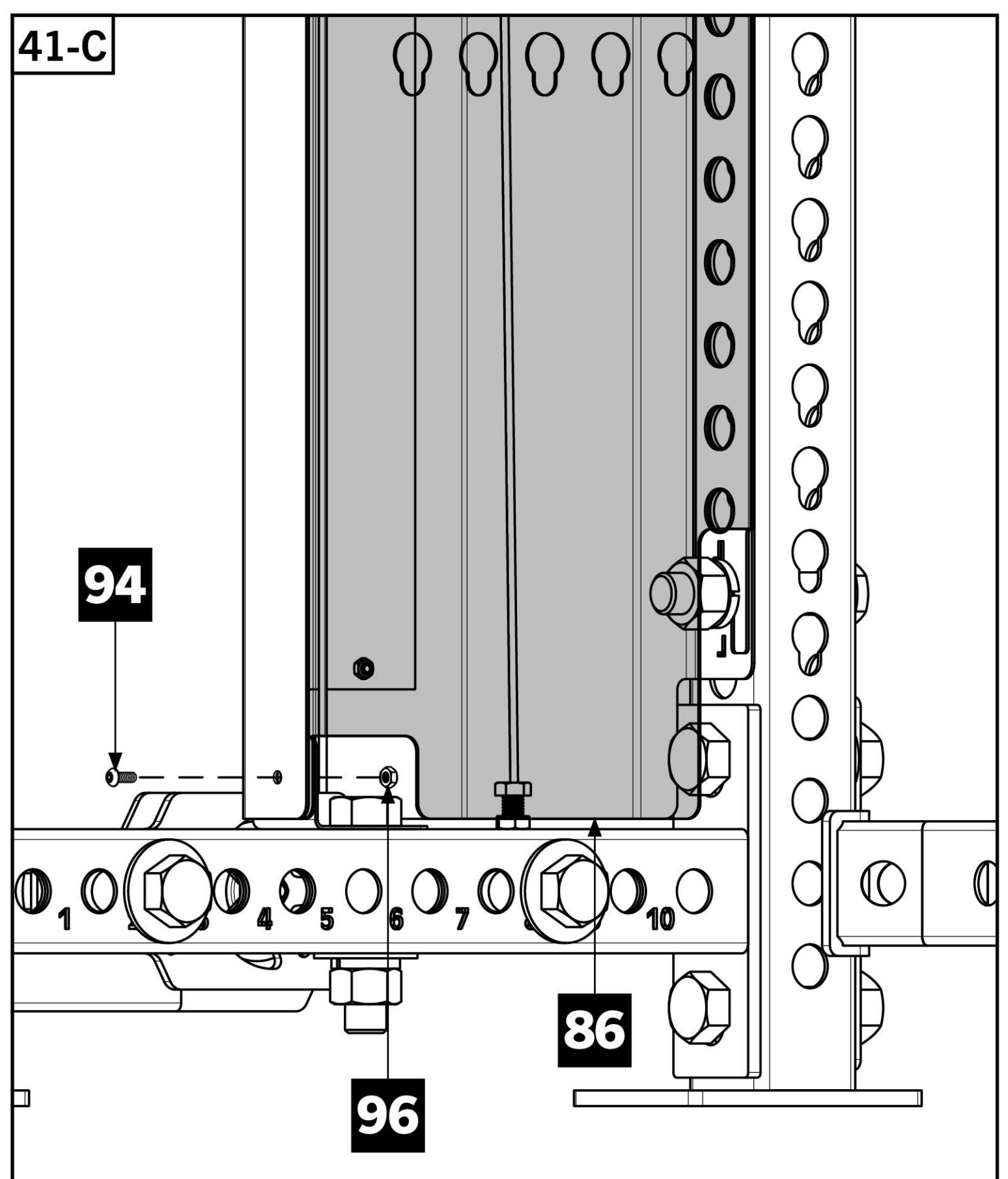
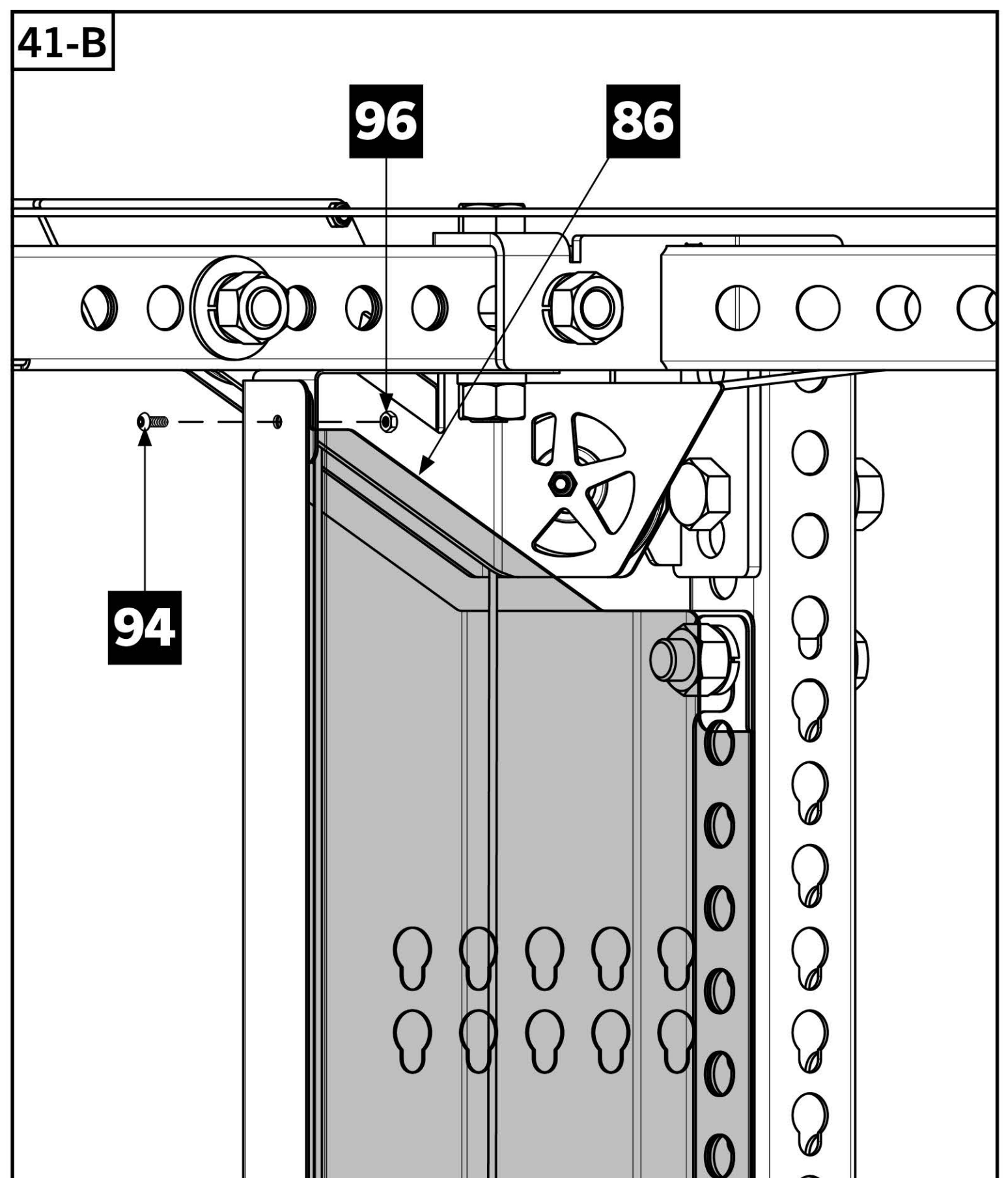
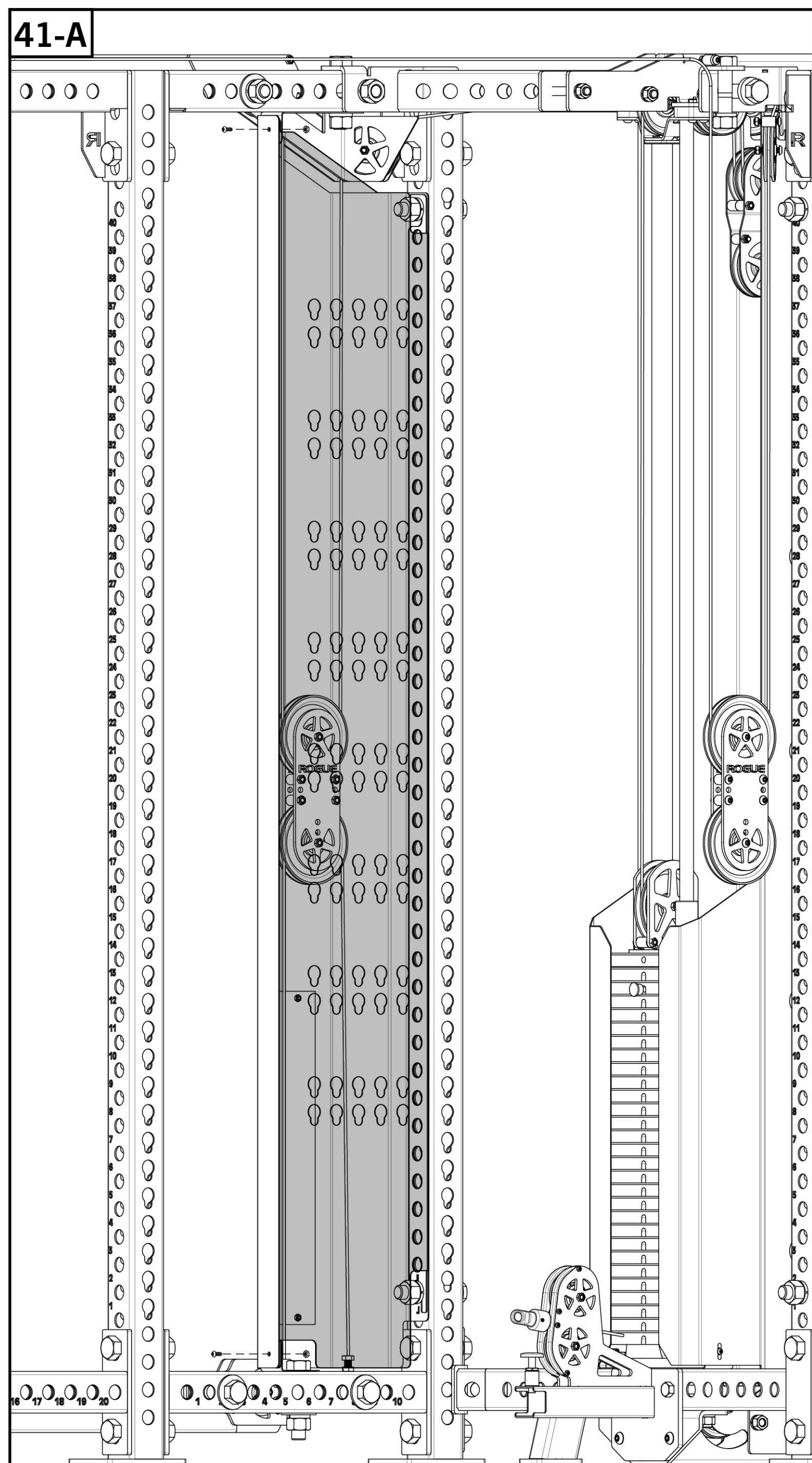
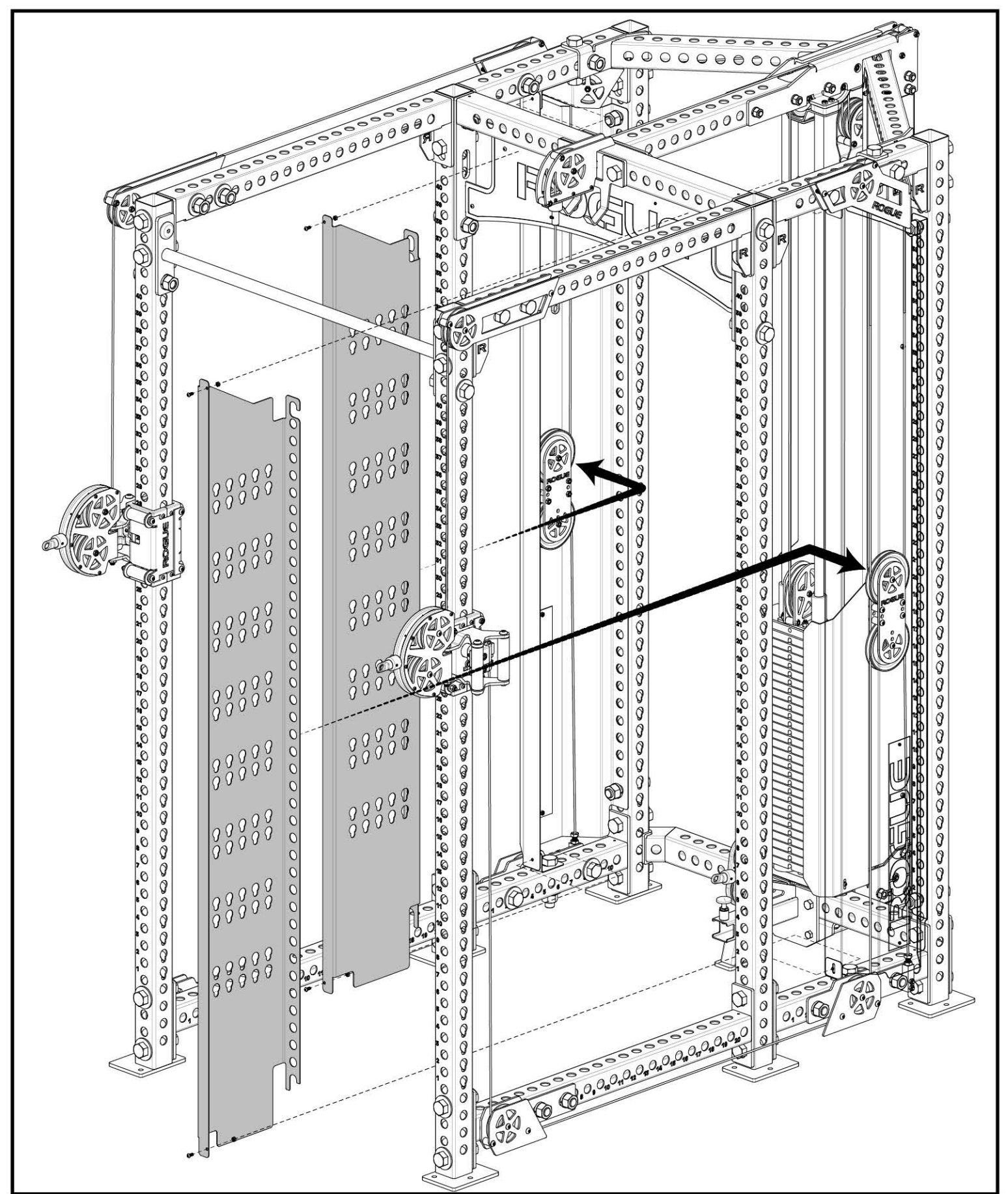

INCLUDED MONSTER STRIP

- *Hardware and tools not included for installing Monster Strips [79].
- (4X) 3/8" x 2-1/2" Wood Lag Screws and (4X) 3/8" Flat Washers (not included) are recommended if mounting Strip to wall or wood stud.
- 15/64" Diameter drill bit recommended if using 3/8" Lag Screws.
- Identify stud in wall and mark desired height of top hole. Drill pilot hole in marked location.
- Put thread-side of screw through washer then screw through top hole at the back of the Strip into wall until wood but do not fully tighten.
- Let strip hang and ensure it is square using a level then mark locations of the 3 remaining holes.
- Hold strip to the side as shown in **42-B** and drill pilot holes in the 3 marked locations.
- Put thread side of screw through the washer then screw through bottom 3/8" hole in back of Strip into the wall loosely.
- Screw in the remaining two Lag Screws and fully tighten all screws.
- If attempting to secure Strip to concrete or other material, the buyer is responsible for using correct hardware.
- It is the buyer's responsibility to install strip in a location and with hardware capable of supporting the aggregate weight of strip, all gear mounted or stored, and any person using it.
- If you are not confident in your mechanical skills, please seek the help of a professional to perform the installation.

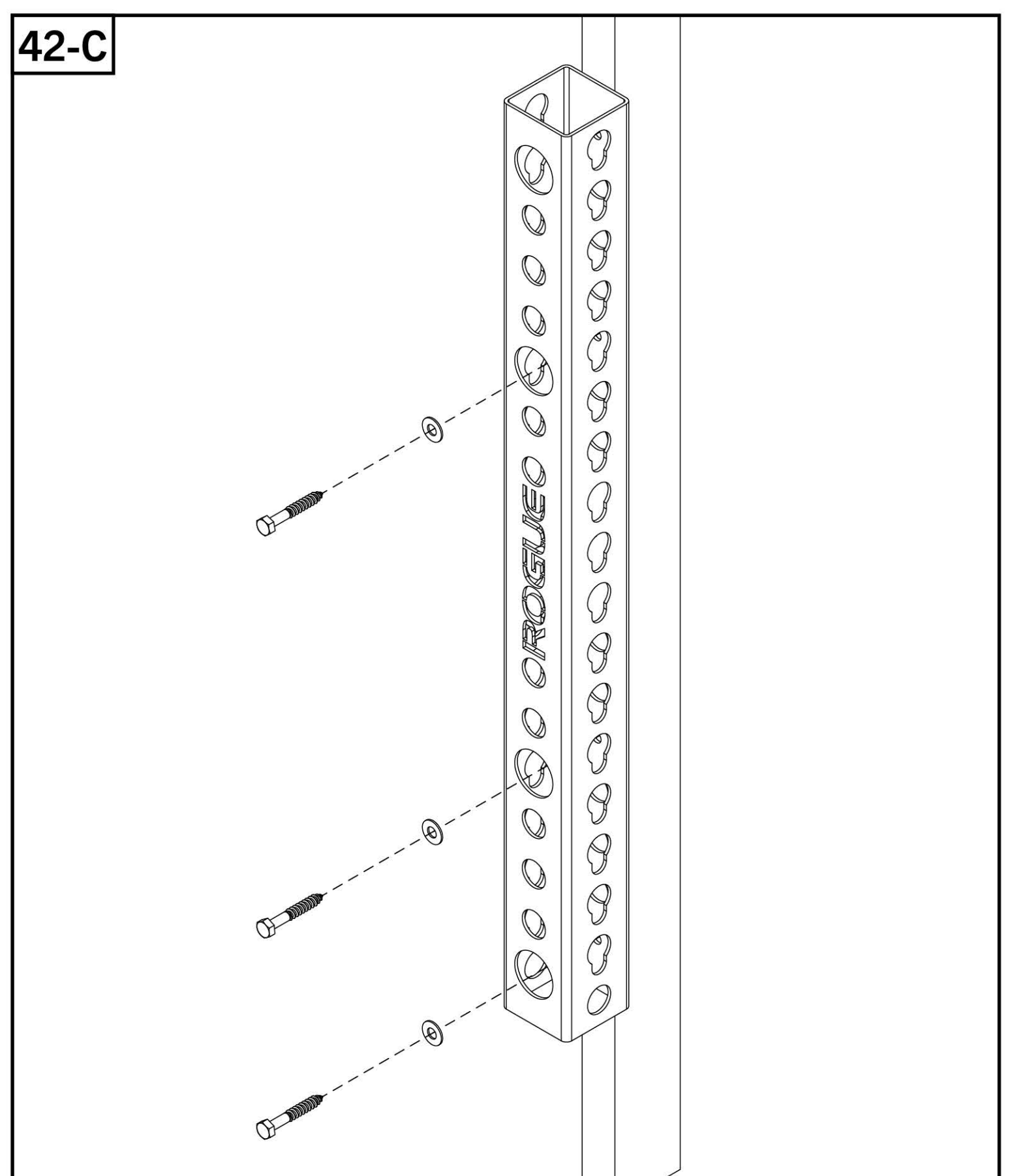
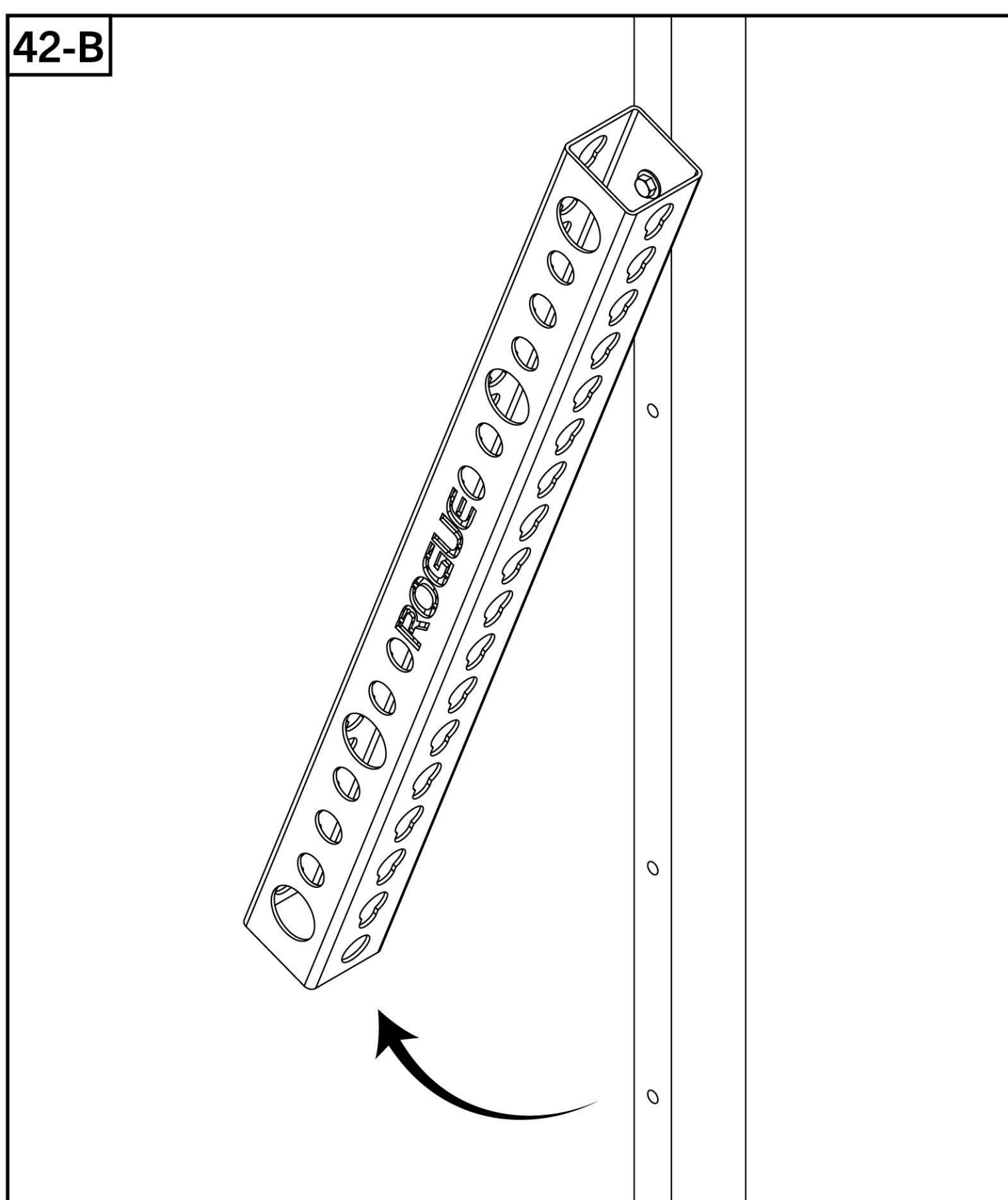
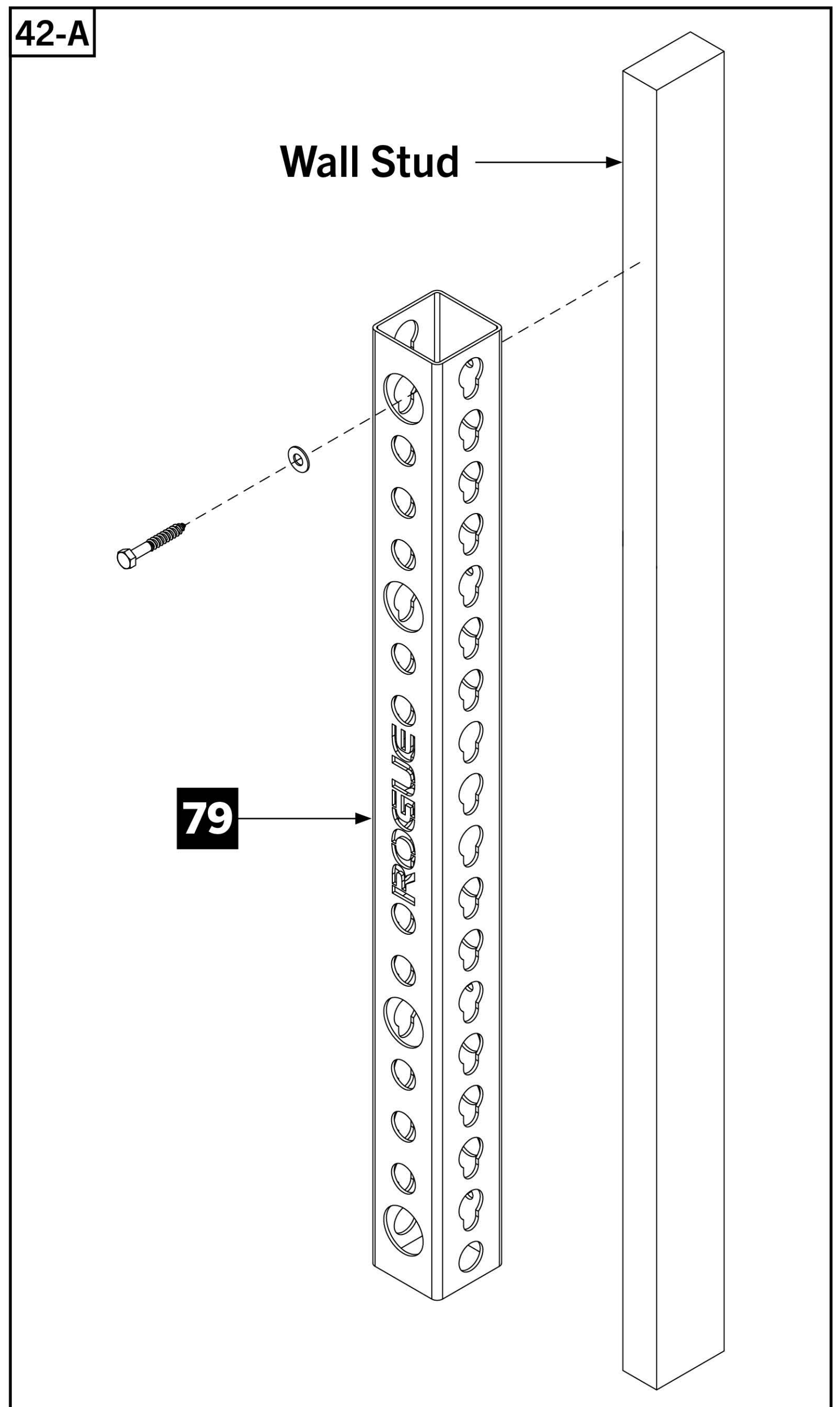
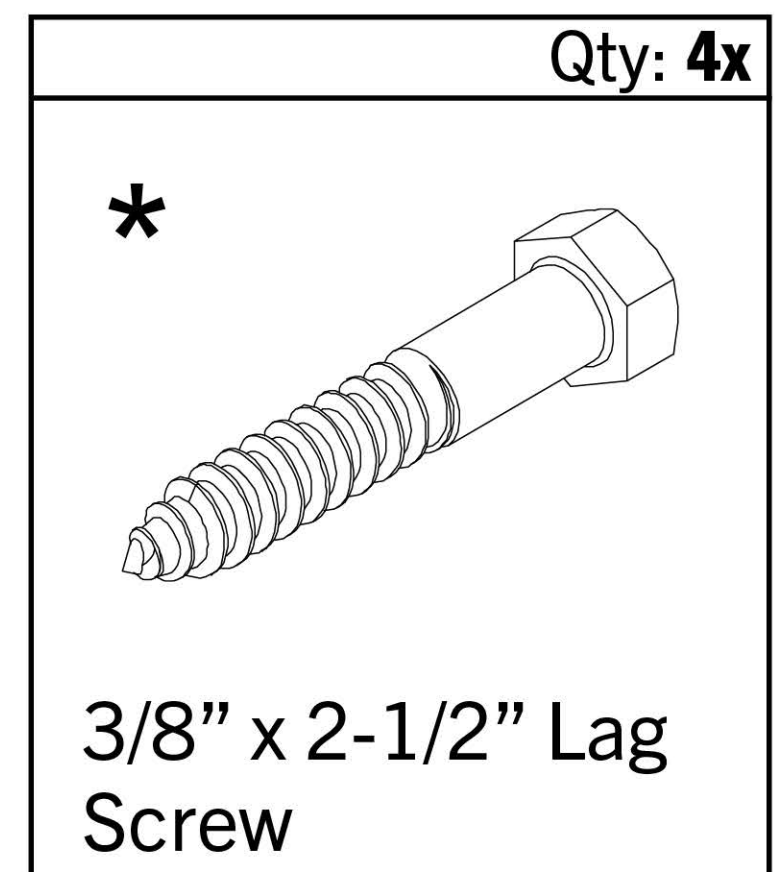
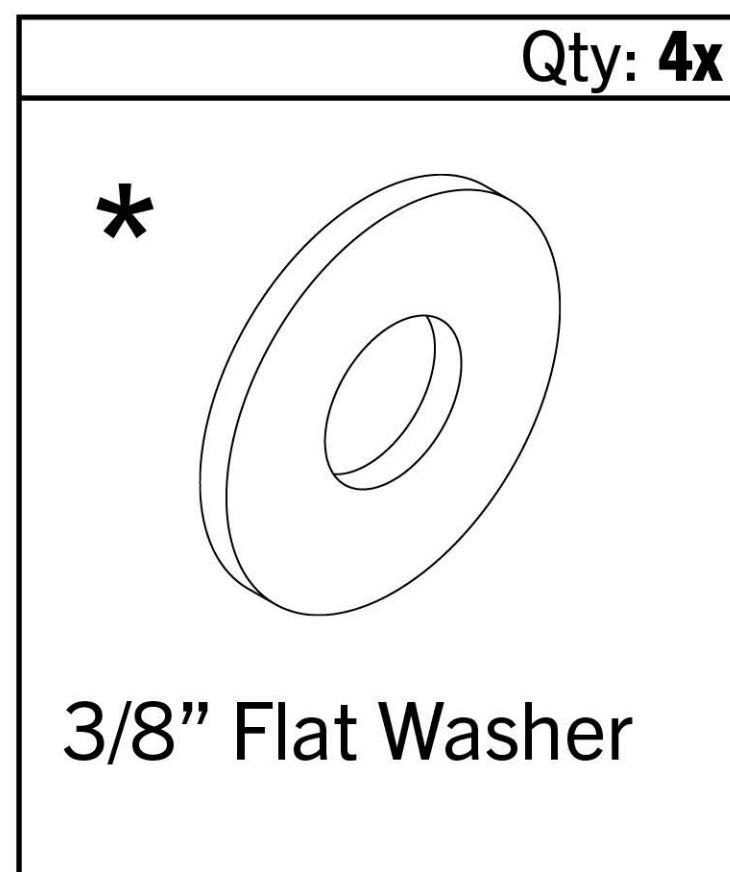

CABLE MAINTENANCE

Over time, the cables within the system may experience some normal inelastic stretching. Follow the below instructions to re-tighten the cables.

STEP 1

Tools Required:

- Multi Tool
- Tighten all four Low Side Cable bolt heads into stop blocks of Swivel Trolleys and Bottom Side Pulley Assemblies and retest the cable tightness.

- If cable system is tight, no further calibration is needed. If cables still have slack, proceed to **STEP 2**.

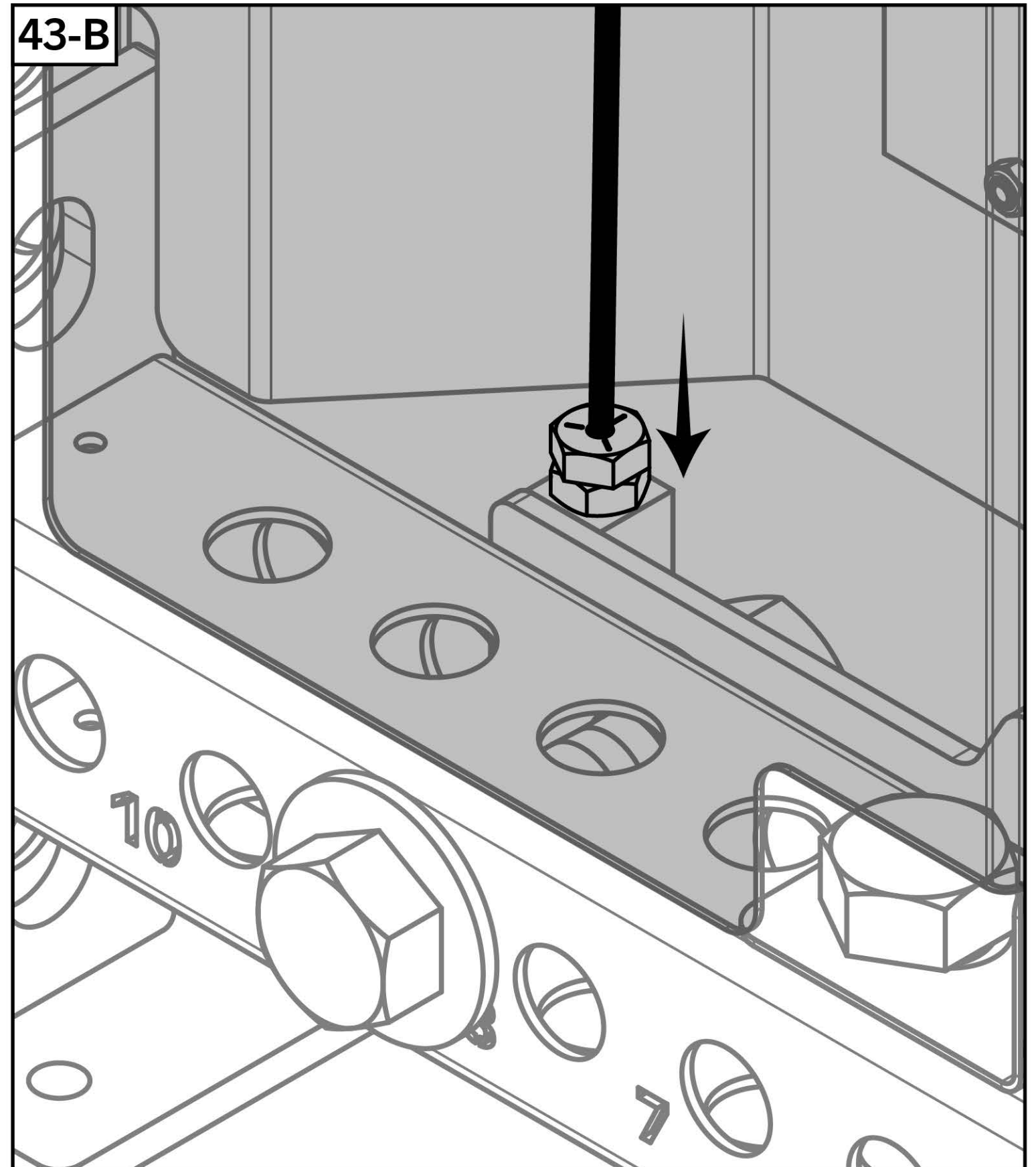
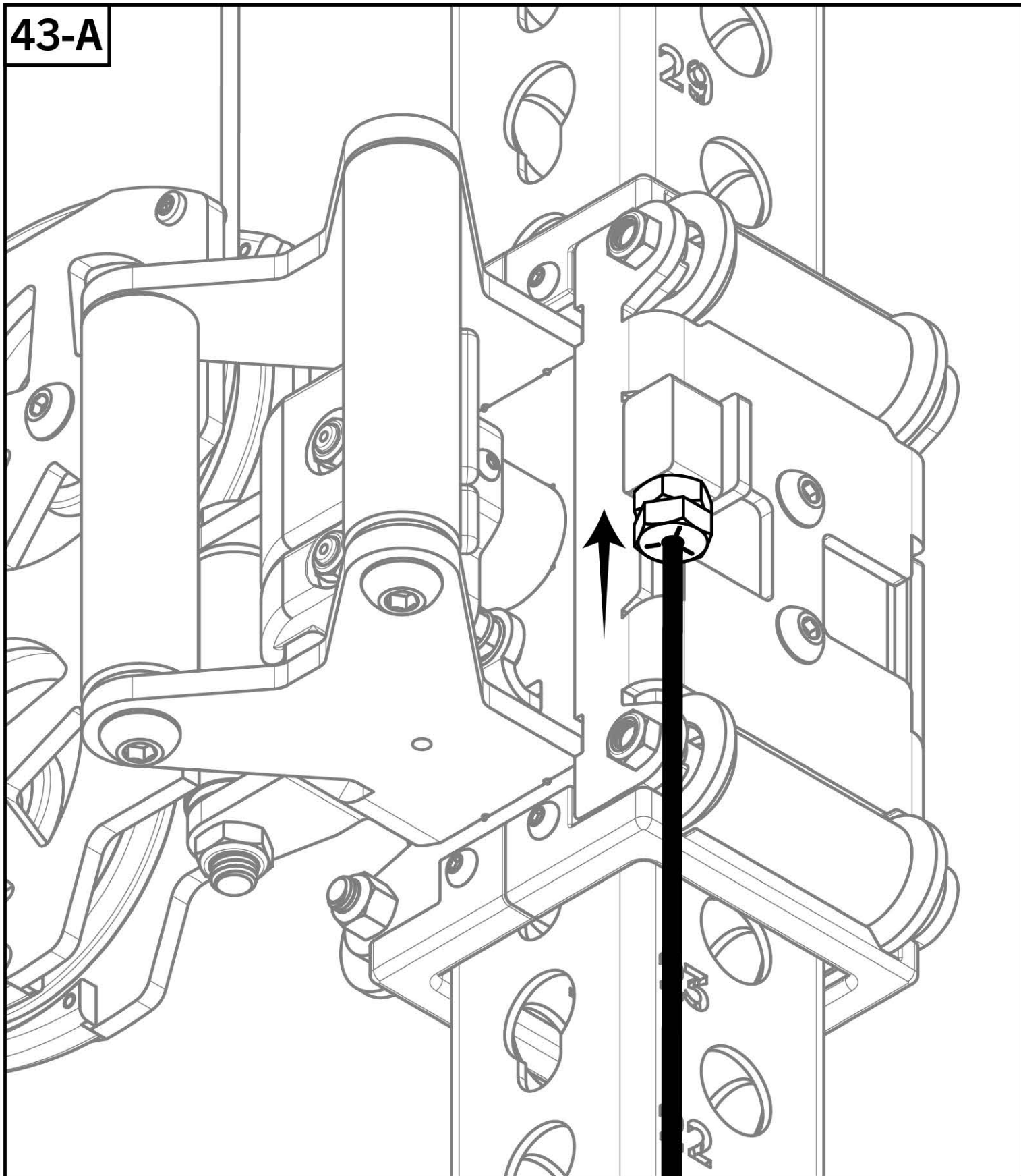

STEP 2

Tools Required:

- Multi Tool, 7/32" Allen Key
- Remove the Weight Stack Shrouds for easier access to the Rear Pulley.
- Lift the top plate stem 6"-8" and pin the stem to introduce slack to the system.

- Remove hardware shown in **44-B** on Rear Pulley Assembly and move Pulley and Cable Retainers up by one hole.
- Re-adjust the height of the Trolley Cable Bolts shown in **STEP 1** to calibrate the cable tightness.

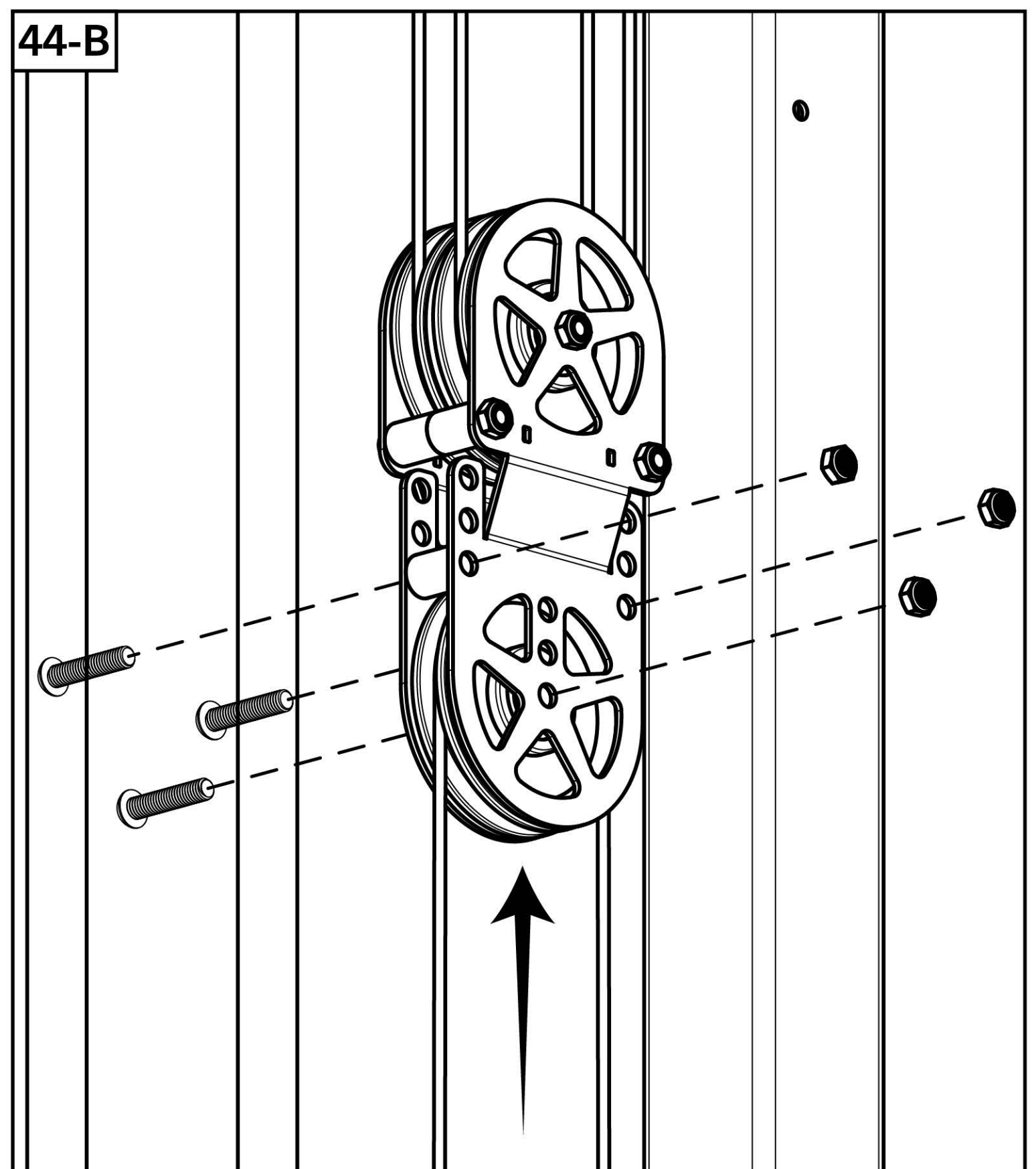
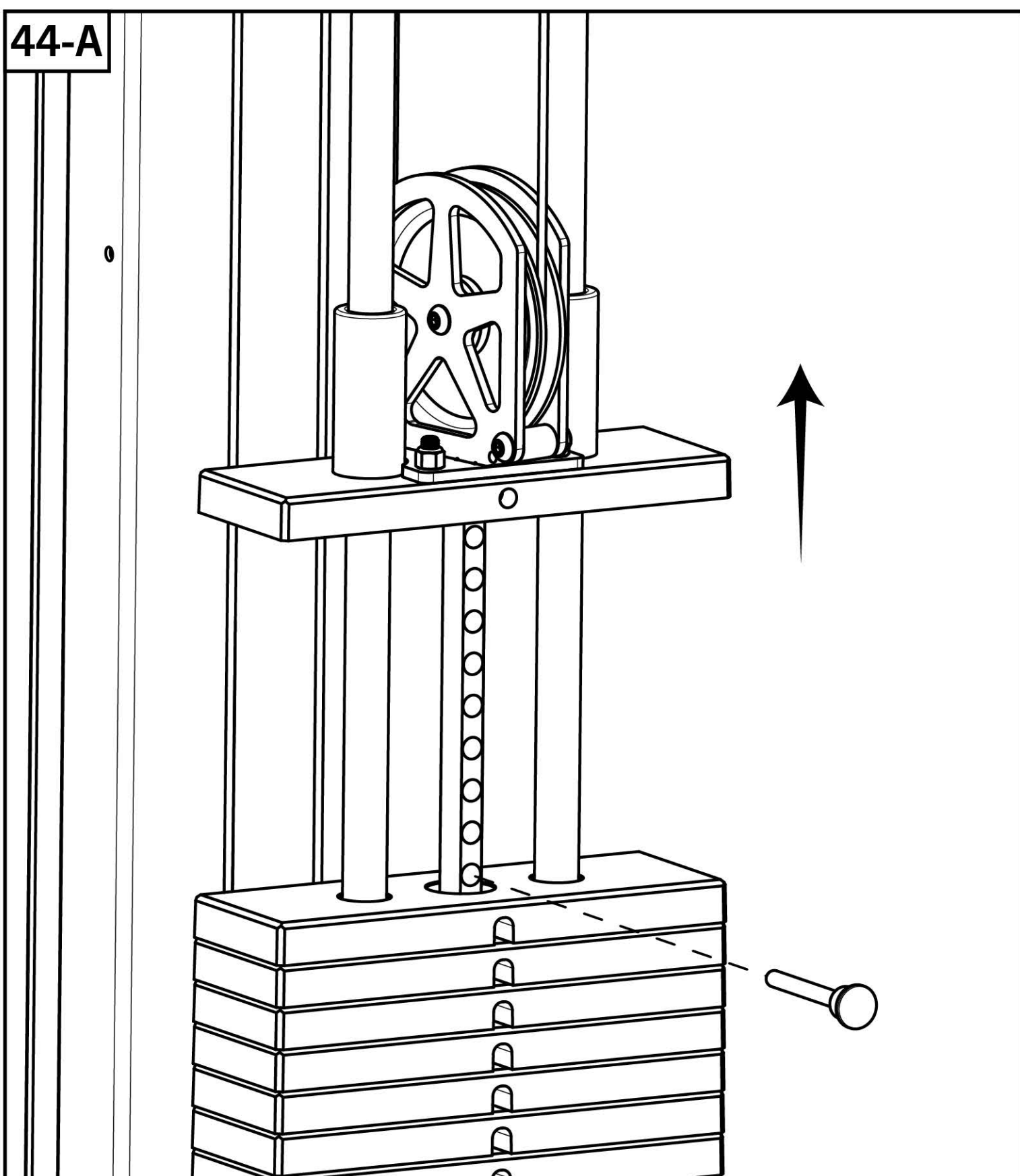

STEP 2 (CONTINUED)

- If slack persists, move Retainers and Pulley to the uppermost calibration hole and test again until cables are taut but aren't pulling up the weight stack.
- Carefully un-pin the top plate of the weight stack stem and lower plate back down to the rest of the stack.

- If the Pulley is in the uppermost hole and there is still slack in the cables, proceed to **STEP 3**.

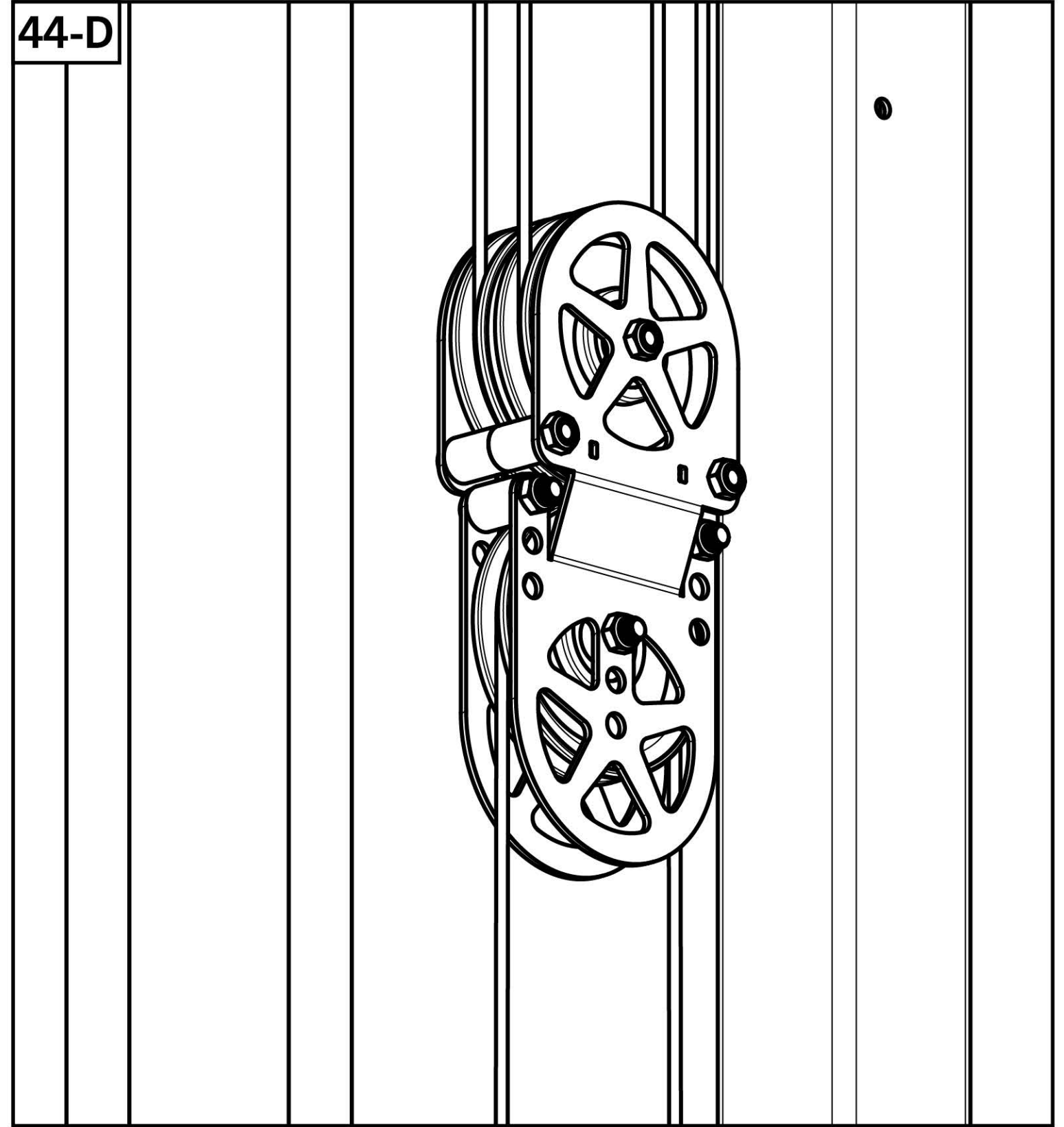
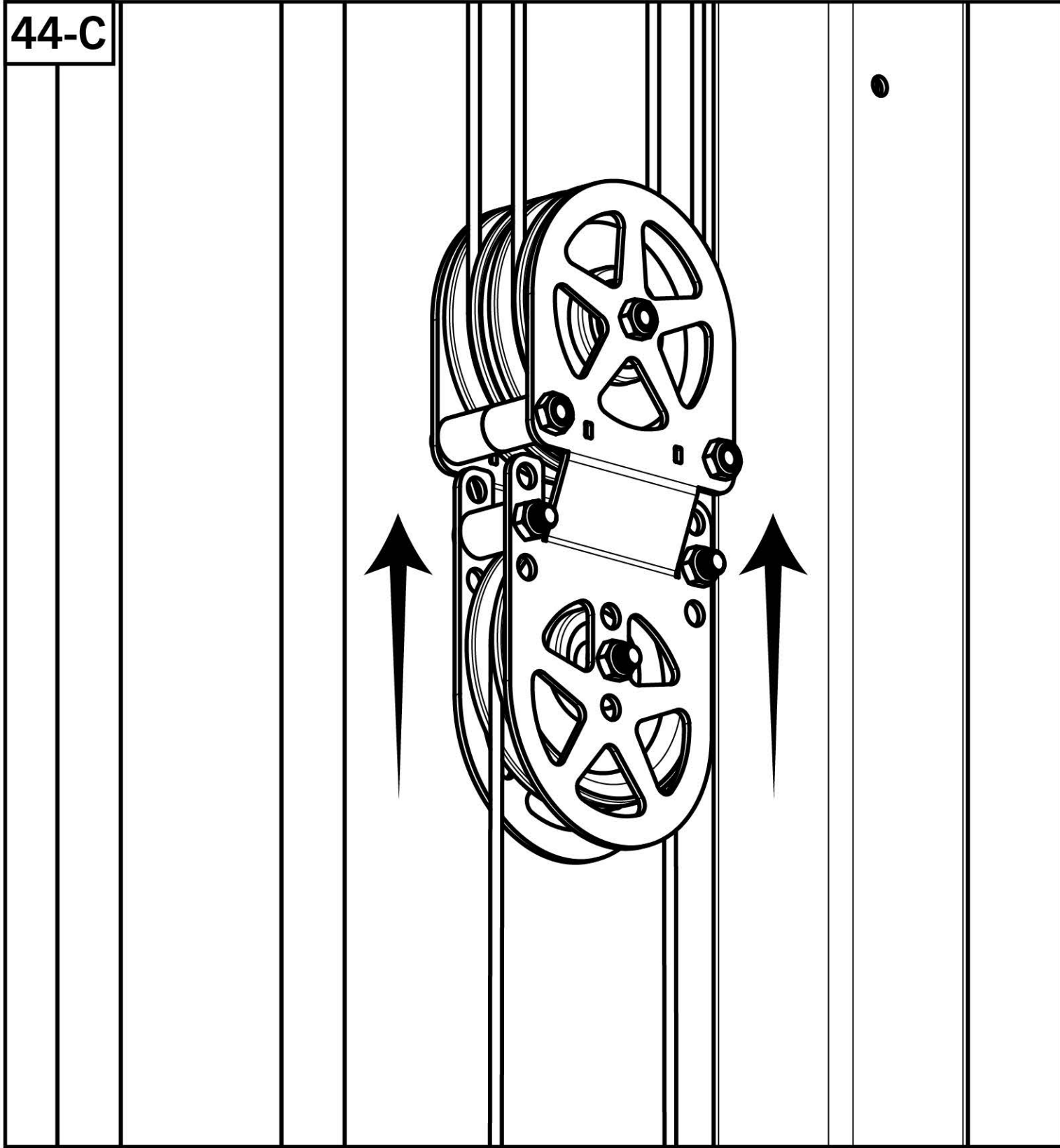

STEP 3

- Remove the Shroud Storage Panel - RH [84].
- Remove Cable Retainers and hardware from Side Peanut Pulley and move pulley up by one hole.
- Re-adjust the height of the Trolley Cable Bolts to calibrate the cable tightness.
- If slack persists, perform the same pulley relocation on the Left Side Peanut Pulley. Recalibrate the Trolley cable bolts and check cable tightness.

- If slack is still present, continue repeating process, alternating between the Left and Right Side Peanut Pulleys, raising the pulley by one hole until the whole cable system is taut but not pulling up the weight stack.

Note:

- If installing Pulley on the uppermost hole of the Side Peanut Pulleys, the lower Cable Retainers are not needed.

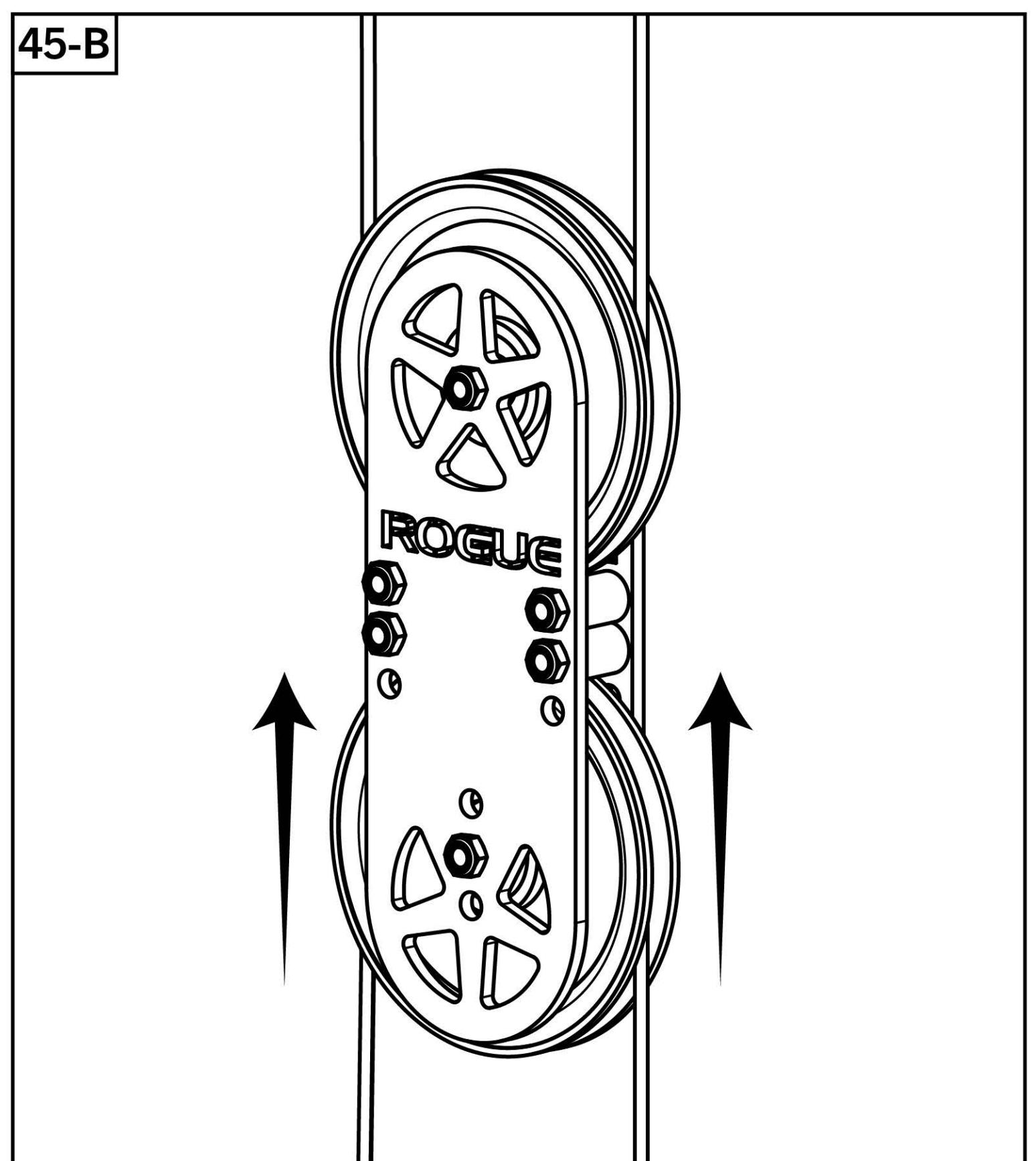
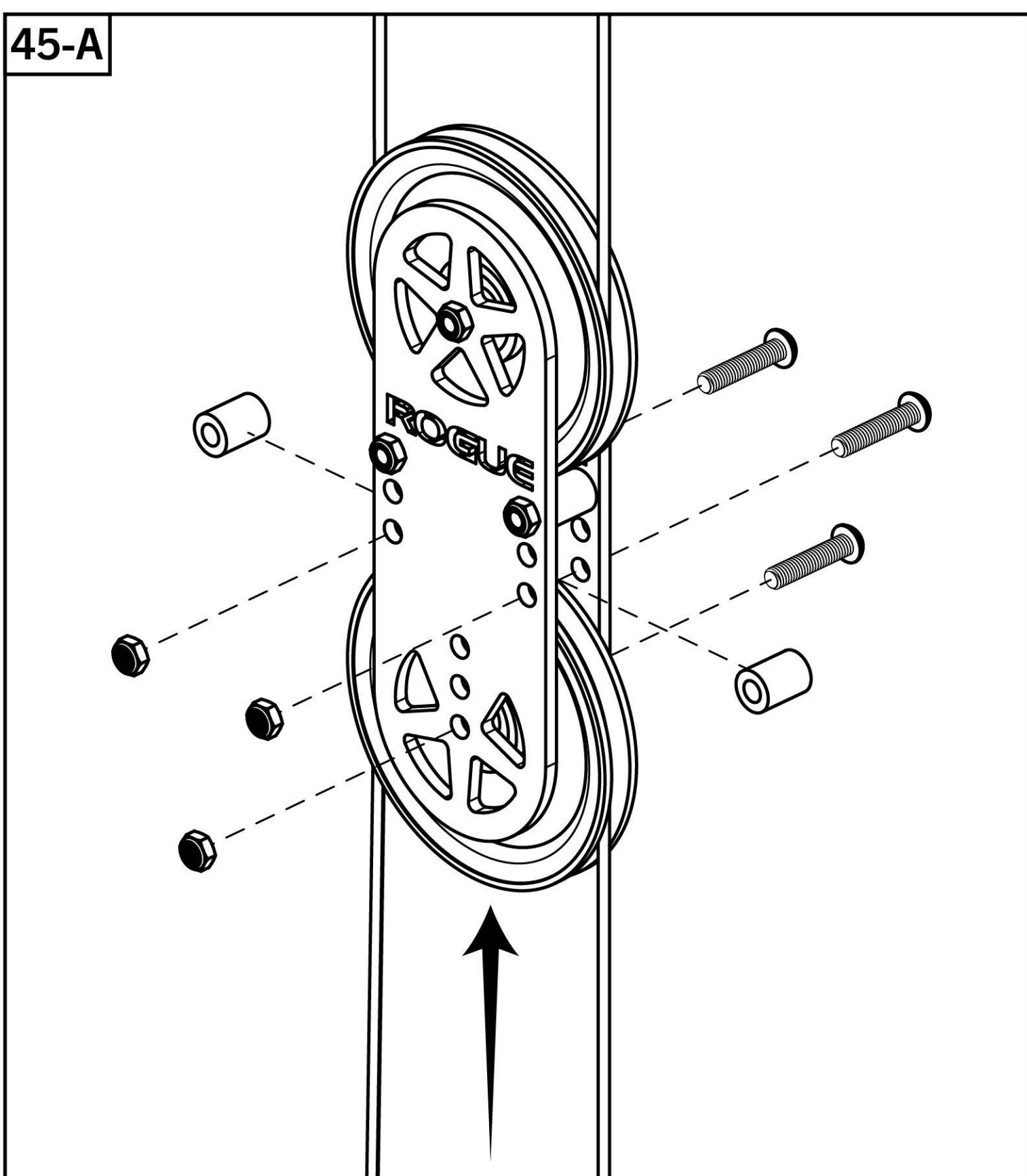

ROGUE



**SCAN FOR
INSTRUCTIONS**



**IRON GAME
PROGRAMMING**