

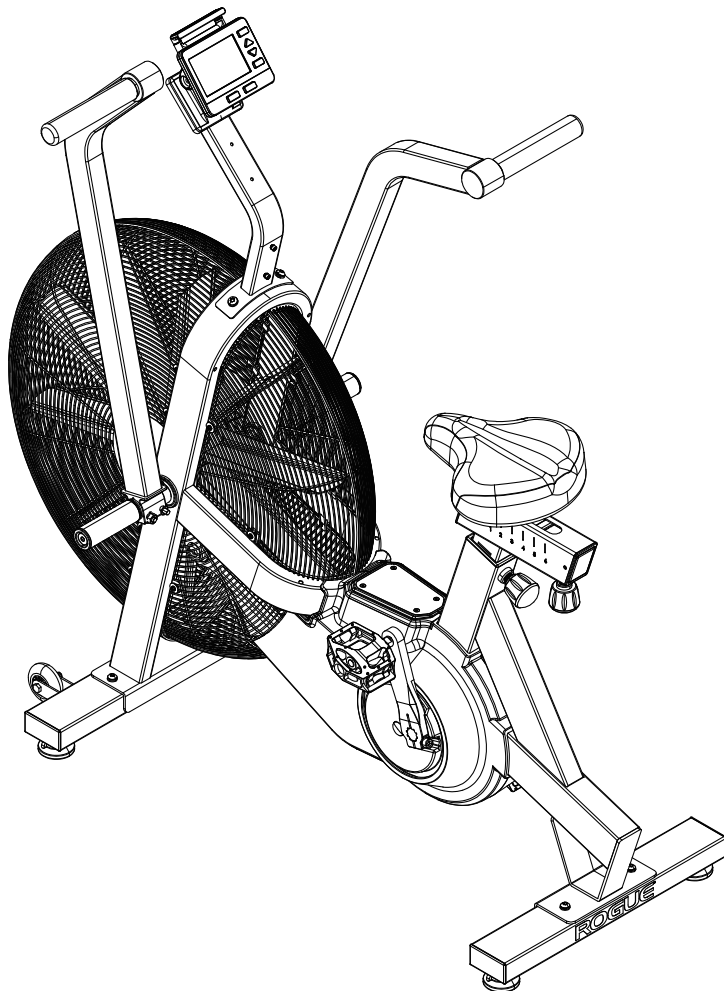



ROGUE

ECHO BIKE M2 UPGRADE KIT

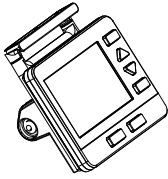
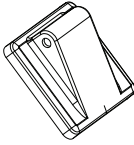
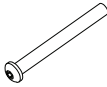

INCLUDED PARTS & TOOLS

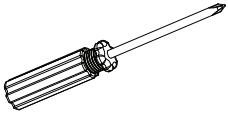
Note images are not shown at scale

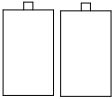
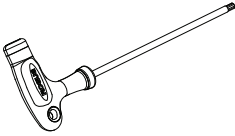
<p>1 Qty: 1x</p>  <p>M2 Console</p>	<p>2 Qty: 1x</p>  <p>Adapter Plate</p>	<p>3 Qty: 1x</p>  <p>Mounting Bolt</p>
<p>4 Qty: 1x</p>  <p>Locking Nut</p>	<p>5 Qty: 4x</p>  <p>Adapter Plate Screws</p>	<p>6 Qty: 1x</p>  <p>Phillips Head Screwdriver</p>
<p>7 Qty: 1x</p>  <p>Sensor Cable</p>	<p>8 Qty: 2x</p>  <p>D-Cell Batteries</p>	<p>9 Qty: 1x</p>  <p>Torx T27</p>

MONITOR SET-UP

Install Batteries:

1. Remove the battery cover from the console by using the provided Phillips head screwdriver **6** to remove the four screws.

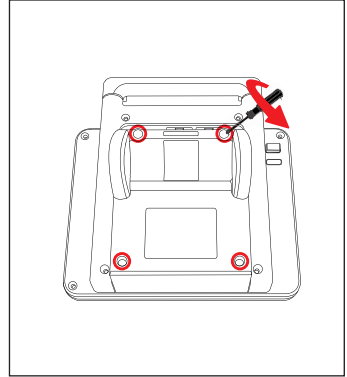

2. Install 2 D-cell (1.5v) batteries **8** aligning positive and negative ends with the corresponding symbols.

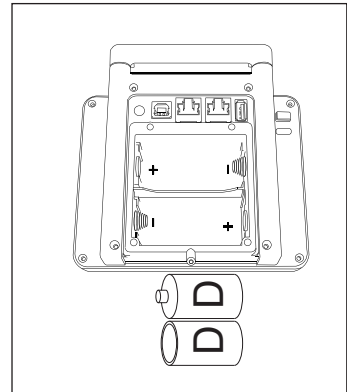

3. Reattach the battery cover and secure using the removed four screws.

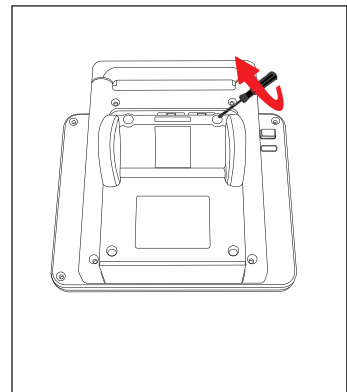

NOTE: REMEMBER TO REMOVE THE BATTERIES FROM THE MONITOR WHEN NOT IN USE FOR A PERIOD OF 3 MONTHS OR MORE.

BUTTONS AND PORTS ON BACK OF MONITOR

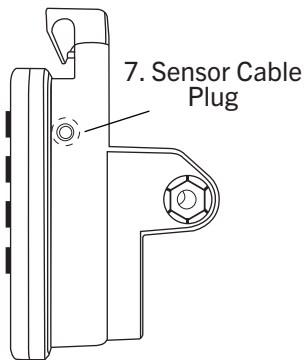
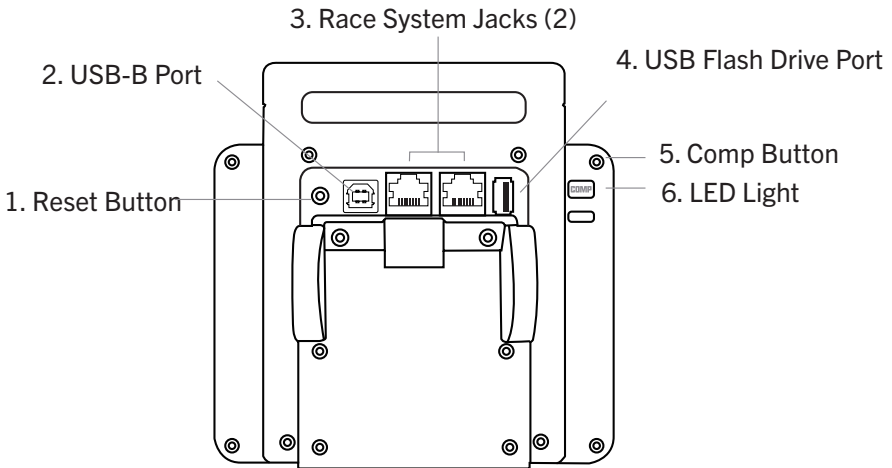

SIDE VIEW

1. RESET BUTTON: To erase all stored data and reset the console to factory settings simply insert a paper clip into the recessed “reset” button and press and hold for at least 5 seconds.

2. USB-B PORT: To connect accessory devices.

3. RACE SYSTEM JACKS: Used for connecting multiple machines for racing.

4. USB FLASH DRIVE PORT: To connect accessory devices.

5. COMP BUTTON: Used to activate Competition Mode. Hold down 2 seconds. In this mode, console time out will change to 12 hours.

6. LED LIGHT: Turns on when Competition Mode is active.

7. SENSOR CABLE PLUG: Plug sensor cable coming from the bike into this plug.

MONITOR DISPLAYS

MAIN MENU

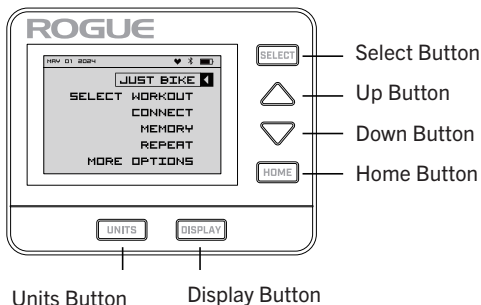

Select Button: Select an option

Up Button: Moves Selector up or increases a value setting

Down Button: Moves Selector down or decreases a value setting

Home Button: Prompts to end workout/ returns previous page

Units Button: Press during workout to change data units (4 options)

Display Button: Press during workout to change data displays (5 options)

Sleep Mode: Return to the main menu and then press Home Button 4 times to turn console off

Displays distance ridden (m), watts, time/500m, or cal/hour. In interval workout rest mode, current interval number is displayed

Time elapsed, remaining workout time, watts, calories or /500m pace

Average time/500m in current workout, average watts, or total calories

Estimated distance /30 minutes. In interval workout mode or single target workout mode, displays target estimate finish time or distance. In interval rest mode, displays total finish distance

WORKOUT SCREEN

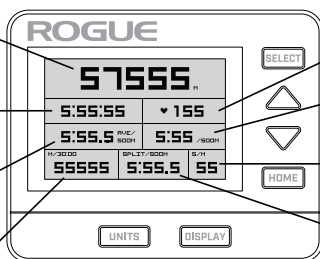

Heart Rate (if connected to a device)

Time /500m, watts, calories, calories/hour. In interval mode, remaining rest time is displayed

Cadence

Split workout results. In interval mode, interval number is displayed

M2 INSTALL INSTRUCTIONS

STEP 1

- Use the Phillips screwdriver **6** to remove the four screws, then disconnect the **A** and **B** connectors and remove the old console. These screws can be discarded.

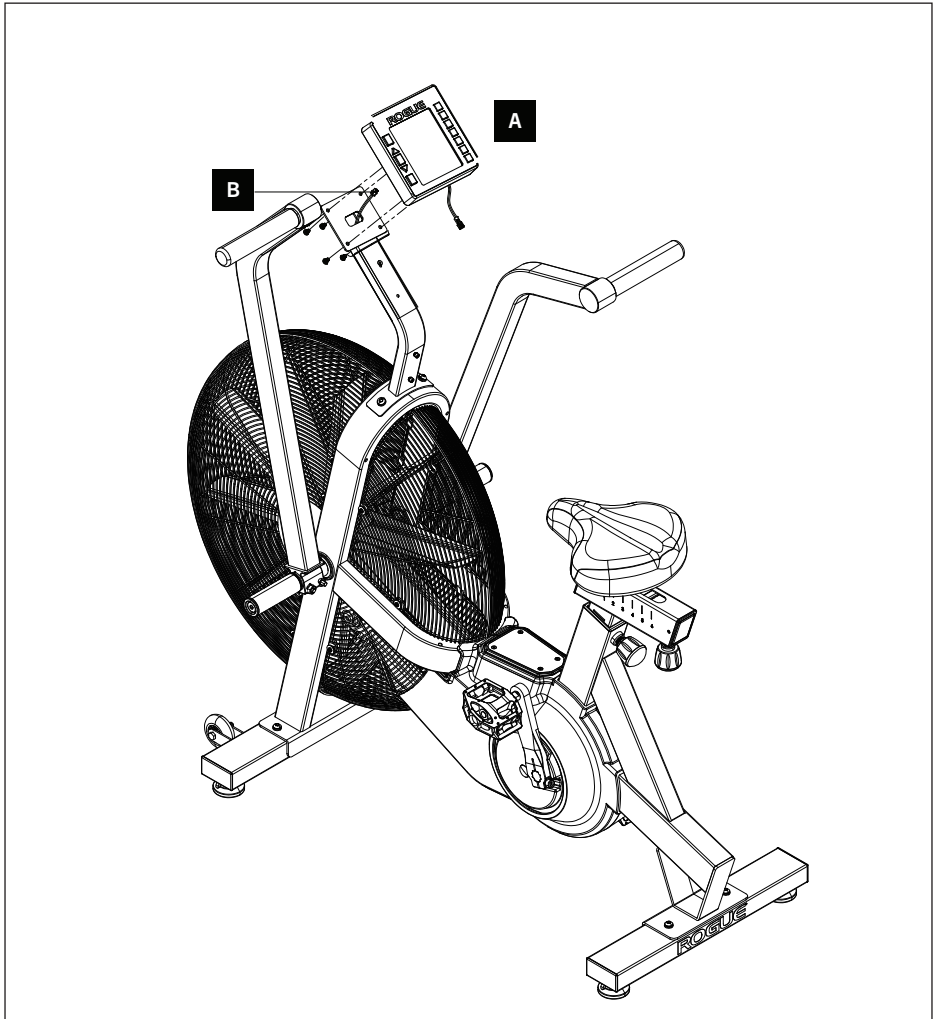

STEP 2

- Take the new cable **7** and join the **A** and **B** connectors.
- Push the joined connector back into the console mast and place the M2 adapter plate **2** onto the top of the mast.
- Ensure there is enough cable visible (around 10cm/4") to connect to the new console and the cable is running in the groove on the back of the adapter plate so it is not trapped or pinched.
- Use the Phillips screwdriver **6** to secure the adapter plate to the console arm using the four new M5 * 8 screws **5**.

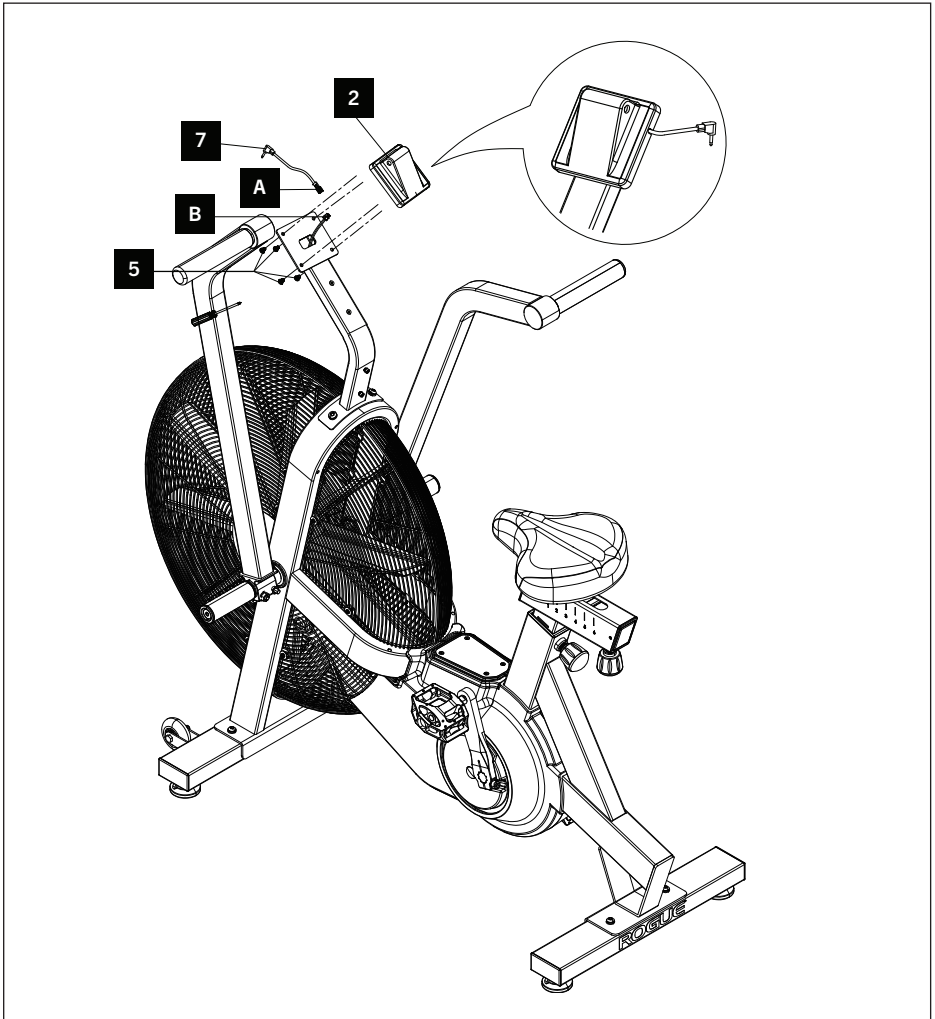

STEP 3

- Secure the M2 console **1** to the adapter plate with the Torx T27 **9** tool using the M8 * 75mm bolt **3** and M8 lock nut **4**.
- Ensure the hex nut **4** is inserted into the hex recess on the right side of the M2 console **1**.
- Plug the cable into the right hand side of the M2 console **1** as shown.

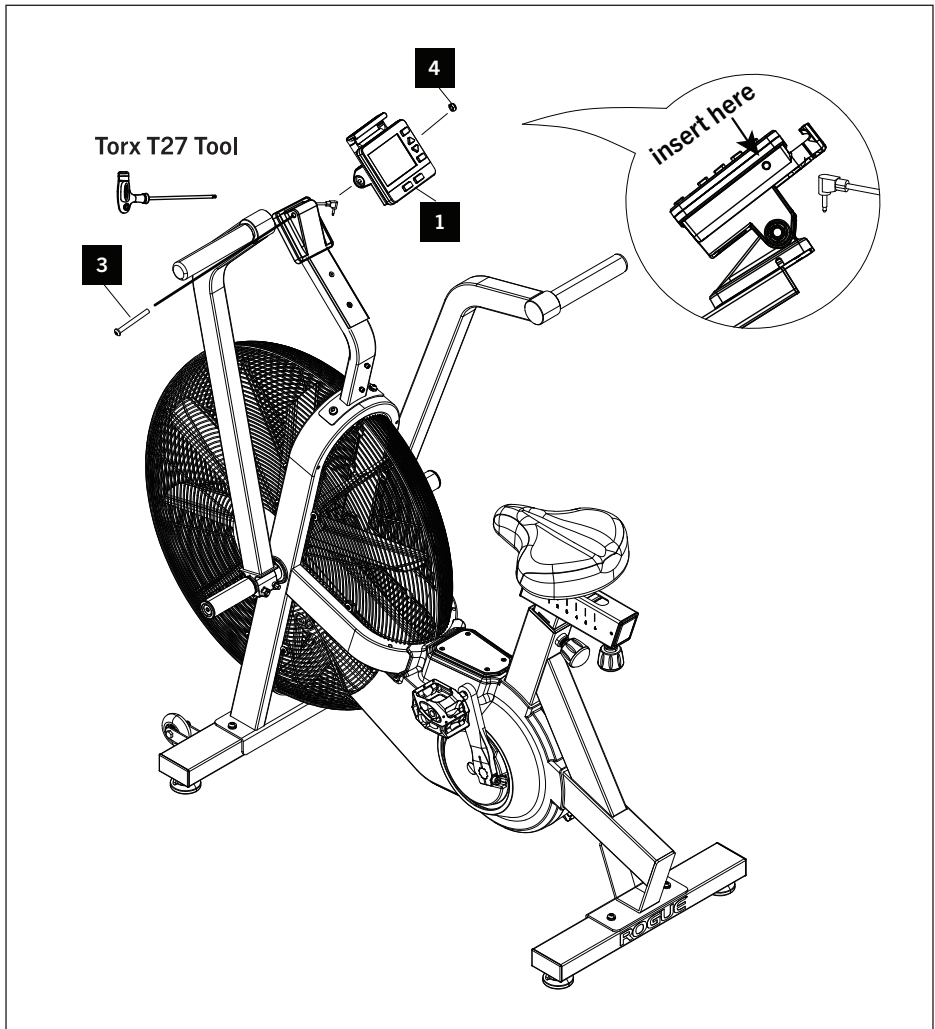

M2 CONSOLE INSTALL COMPLETE

- If you have any questions, please contact Rogue Customer Service: (614) 358-6190 or TEAM@ROGUEFITNESS.COM

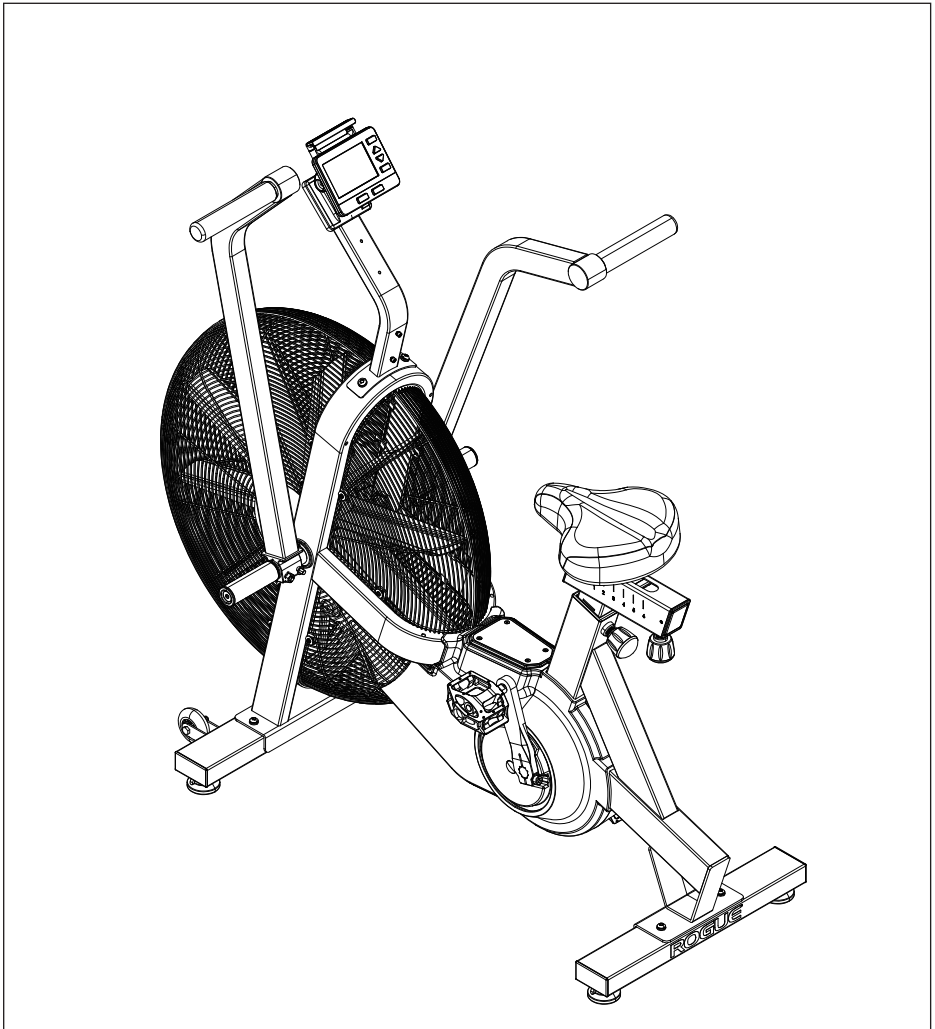

ROGUE



**SCAN FOR
INSTRUCTIONS**

ROGUE



**SCAN FOR IRON
GAME PROGRAMMING**