

ROGUE®

WALL MOUNT INSTRUCTIONS

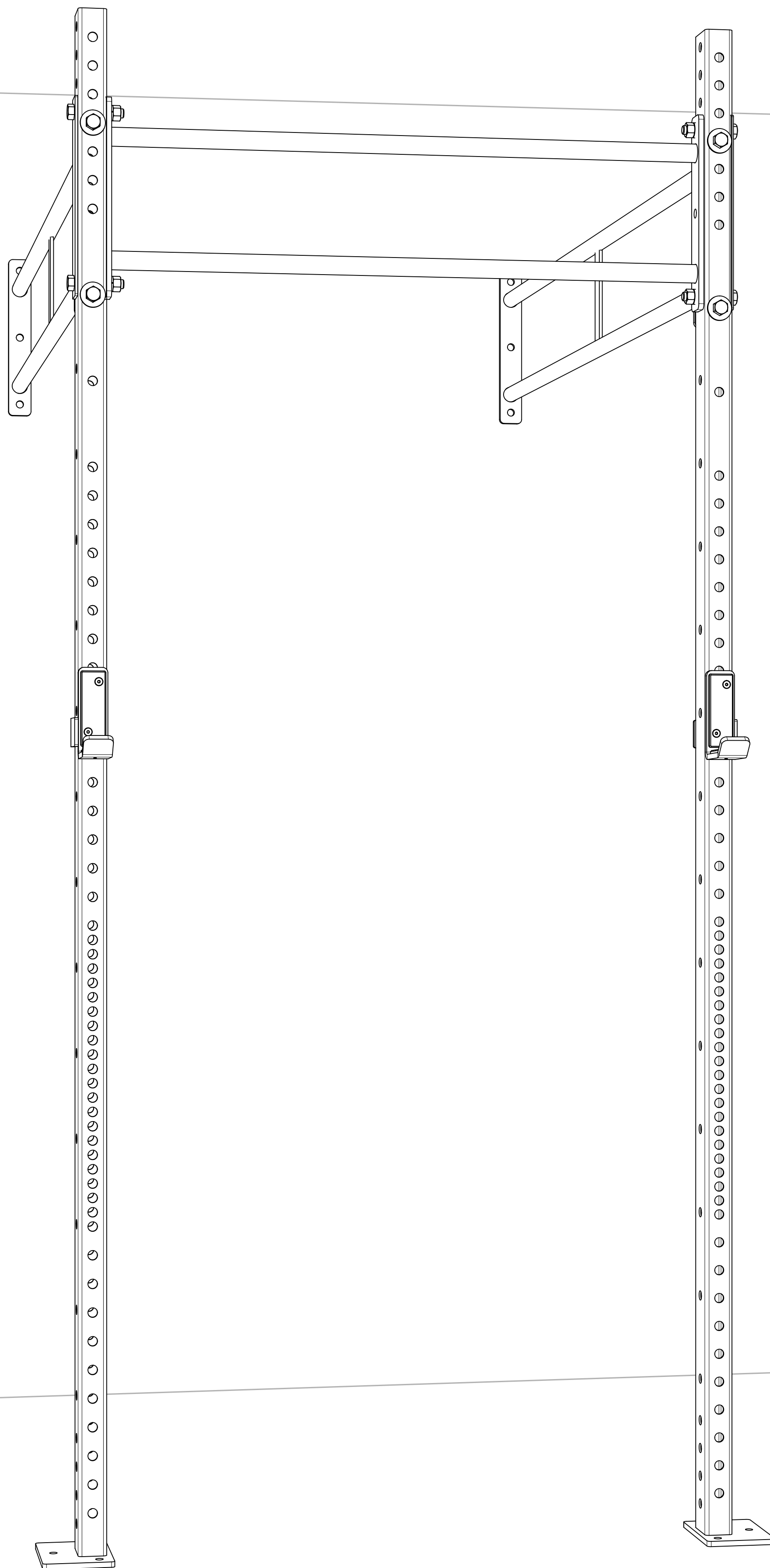

⚠ IMPORTANT SAFETY INFORMATION

DISCLAIMER:

Resistance training, gymnastics training, and activities at height are potentially dangerous and may lead to severe injury or even death. Use common sense when training, obtain instruction in the proper execution of movements, and understand your limitations. This equipment must only be used by competent and responsible persons. Obtaining instruction in appropriate techniques and methods of use is your own responsibility. You assume all risks and responsibilities for all damage, injury or death which may occur during or following incorrect use of this equipment in any matter whatsoever. Rogue Fitness bears no liability beyond the replacement value of the equipment in question.

WARNING:

MISUSE OF THIS PRODUCT CAN RESULT IN SEVERE INJURY. Both Rogue Fitness and buyer disclaim any express or implied warranty, including, without limitation, warranties or merchantability and/or fitness for a particular purpose with respect to the equipment. Buyer assumes all liability to use of equipment.

INCLUDED PARTS

Note: Images not shown at scale

1 Qty: **2x**

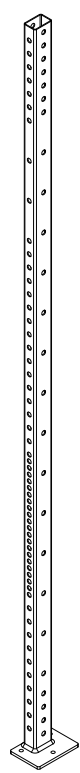

108" SPX Rack Leg

2 Qty: **1x**

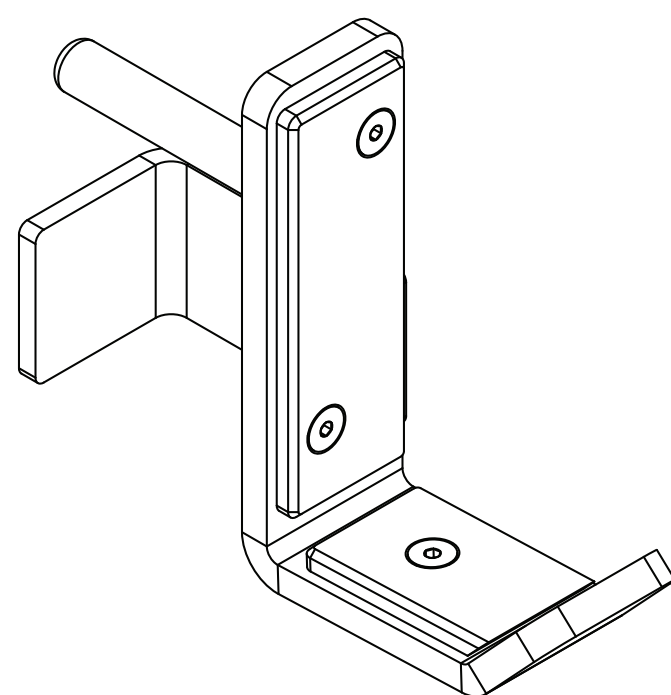

J Cup - RIGHT

3 Qty: **1x**

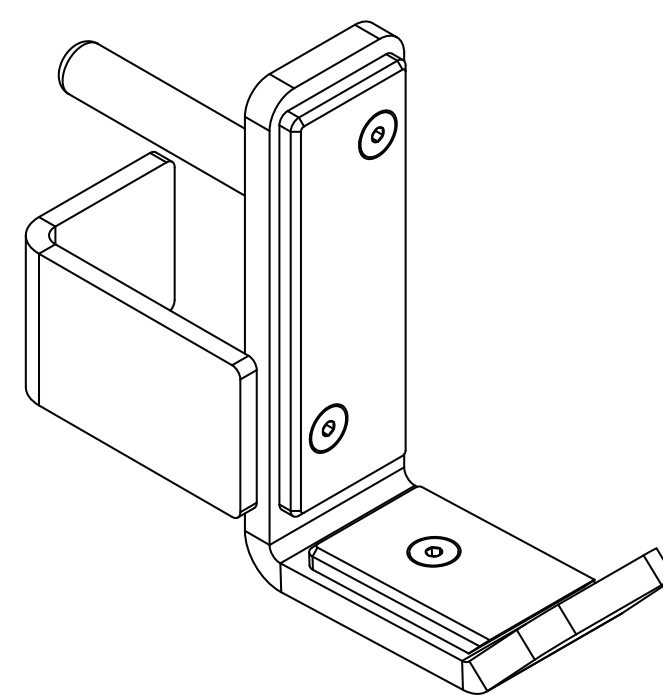

J Cup - LEFT

4 Qty: **4x**

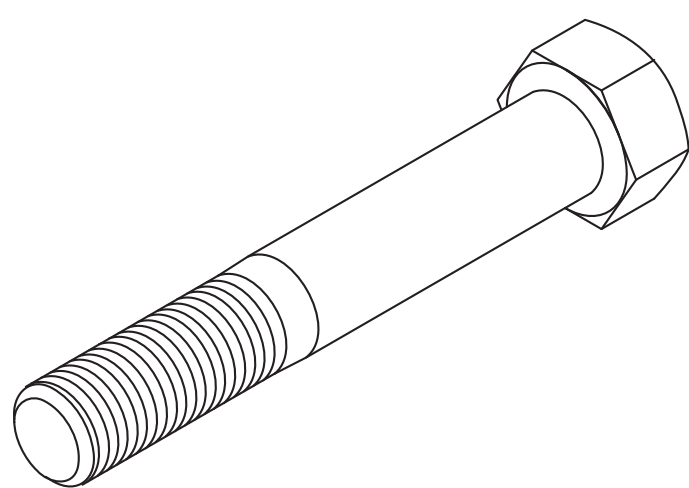

5/8" x 4.5" Hex Screw

5 Qty: **4x**

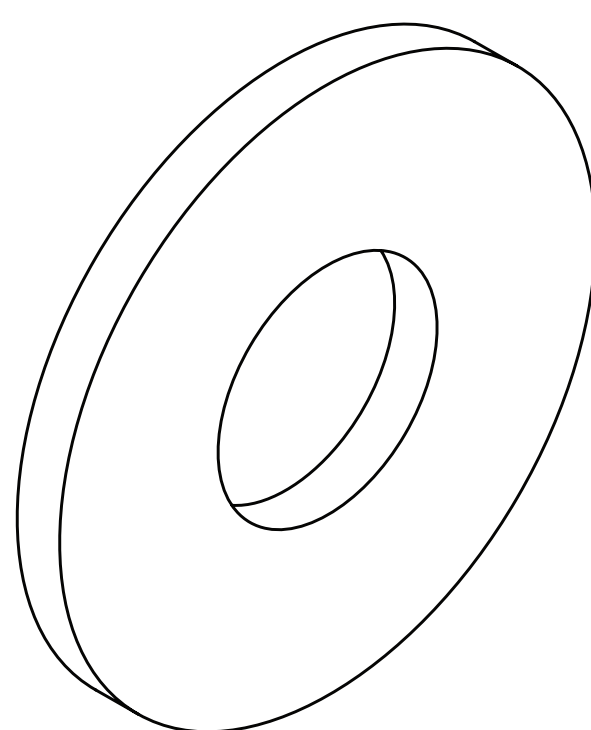

5/8" Flat Washer

6 Qty: **8x**

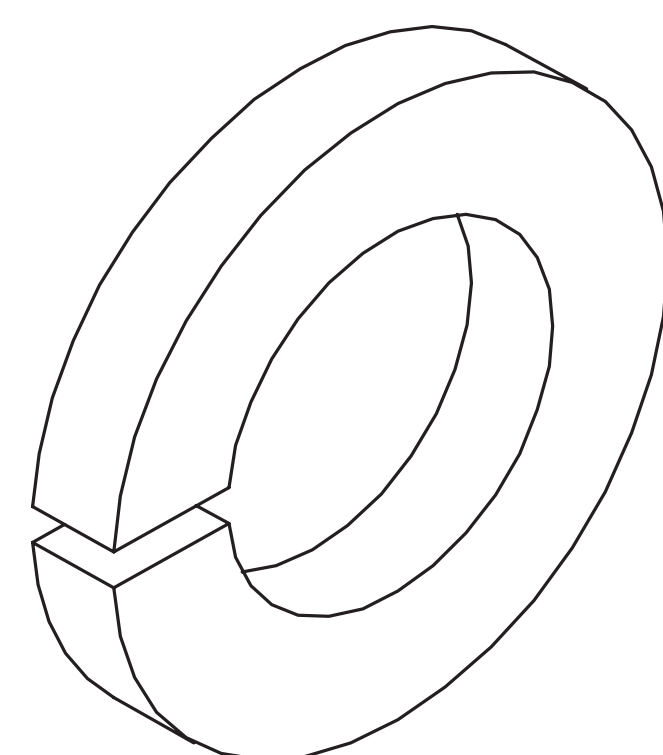

5/8" Lock Washer

7 Qty: **8x**

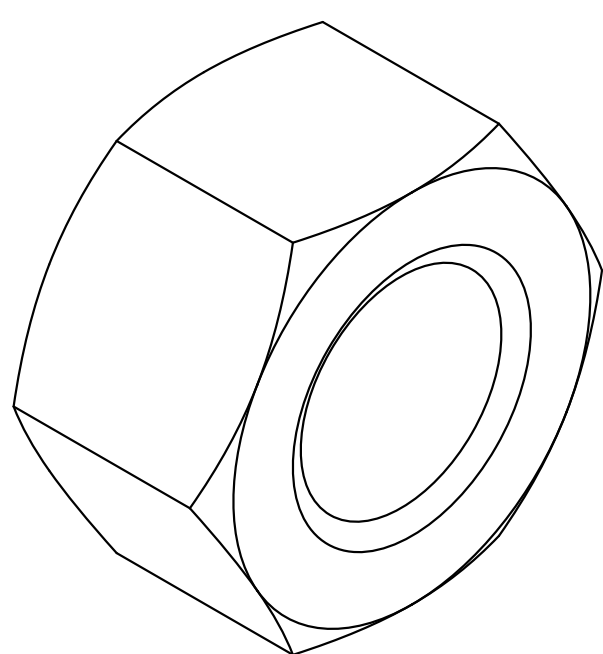

5/8" Hex Nut

8 Qty: **1x**

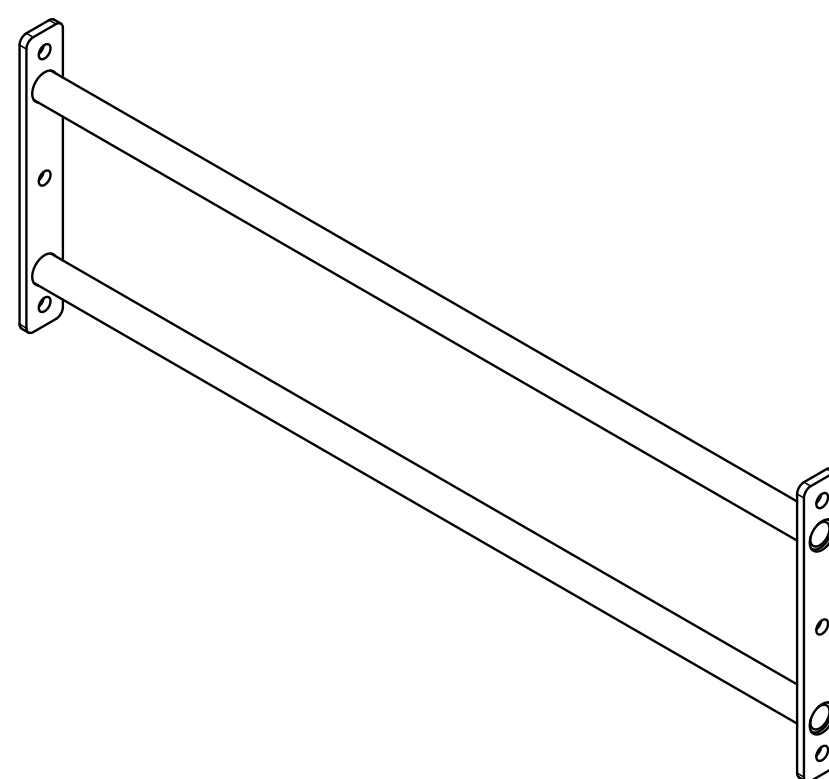

43" Parallel Bar

9 Qty: **2x**

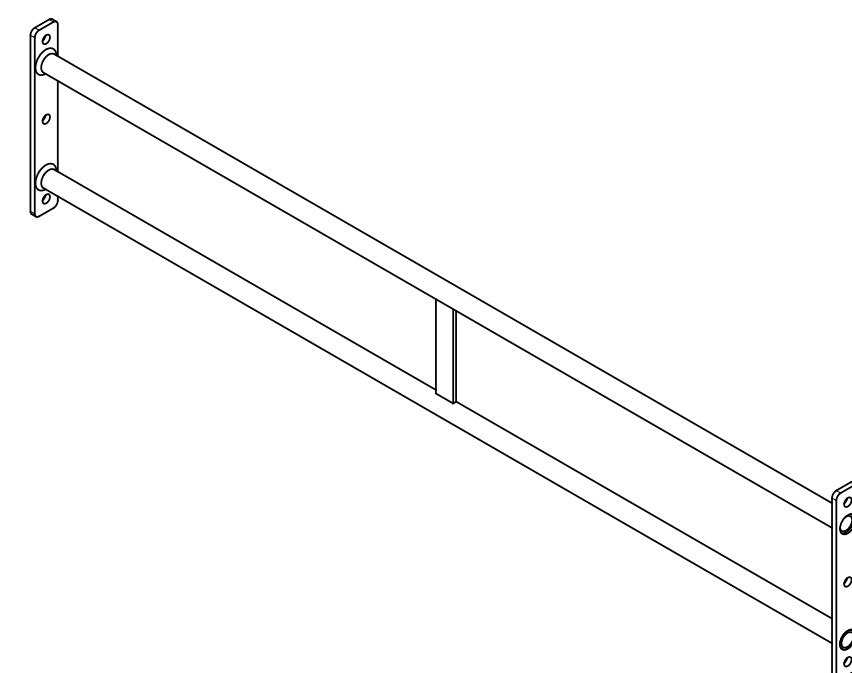

X-70 Parallel Crossmember

10 Qty: **2x**

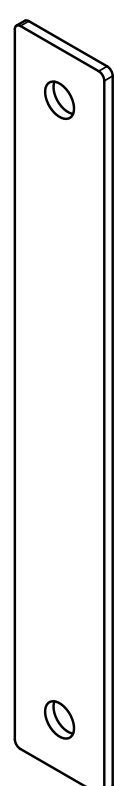

14" SPX Rack Washer Plate

11 Qty: **4x**

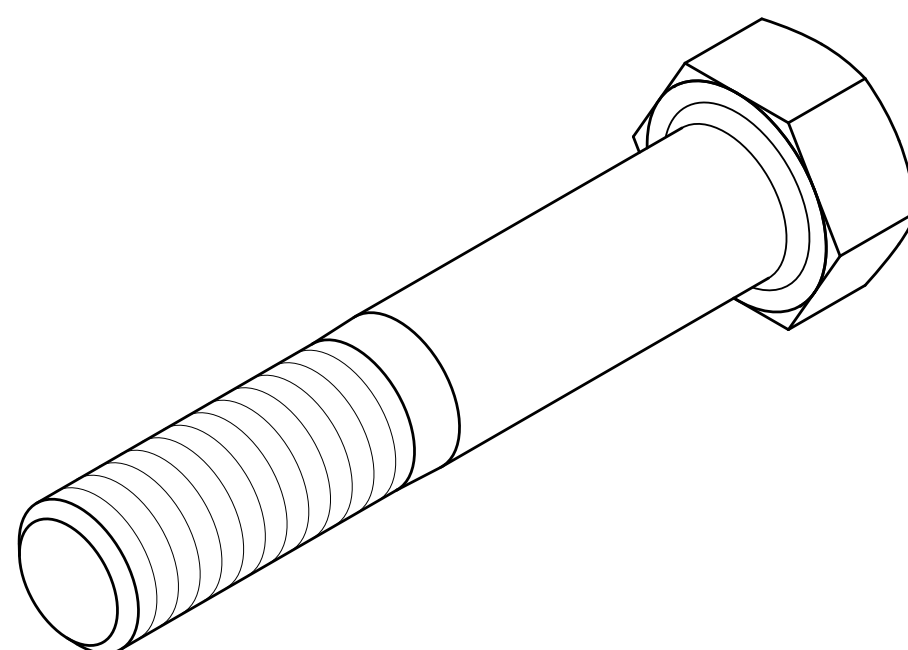

5/8" x 3.5" Hex Screw

STEP 1

- Attach 43" Parallel Bar [8] to 108" SPX Rack Legs [1] using 5/8" x 3.5" Hex Screws [11], 14" SPX Rack Washer Plates [10], 5/8" Lock Washer [6], and 5/8" Hex Nut [7].
- Ensure feet point out as shown in **DETAIL**.

- Do not fully tighten hardware until the entire rack is assembled. This will ensure that the rack sits level to the floor.
- Do not bolt rack to the floor until it is fully assembled and all hardware is tightened.

DETAIL

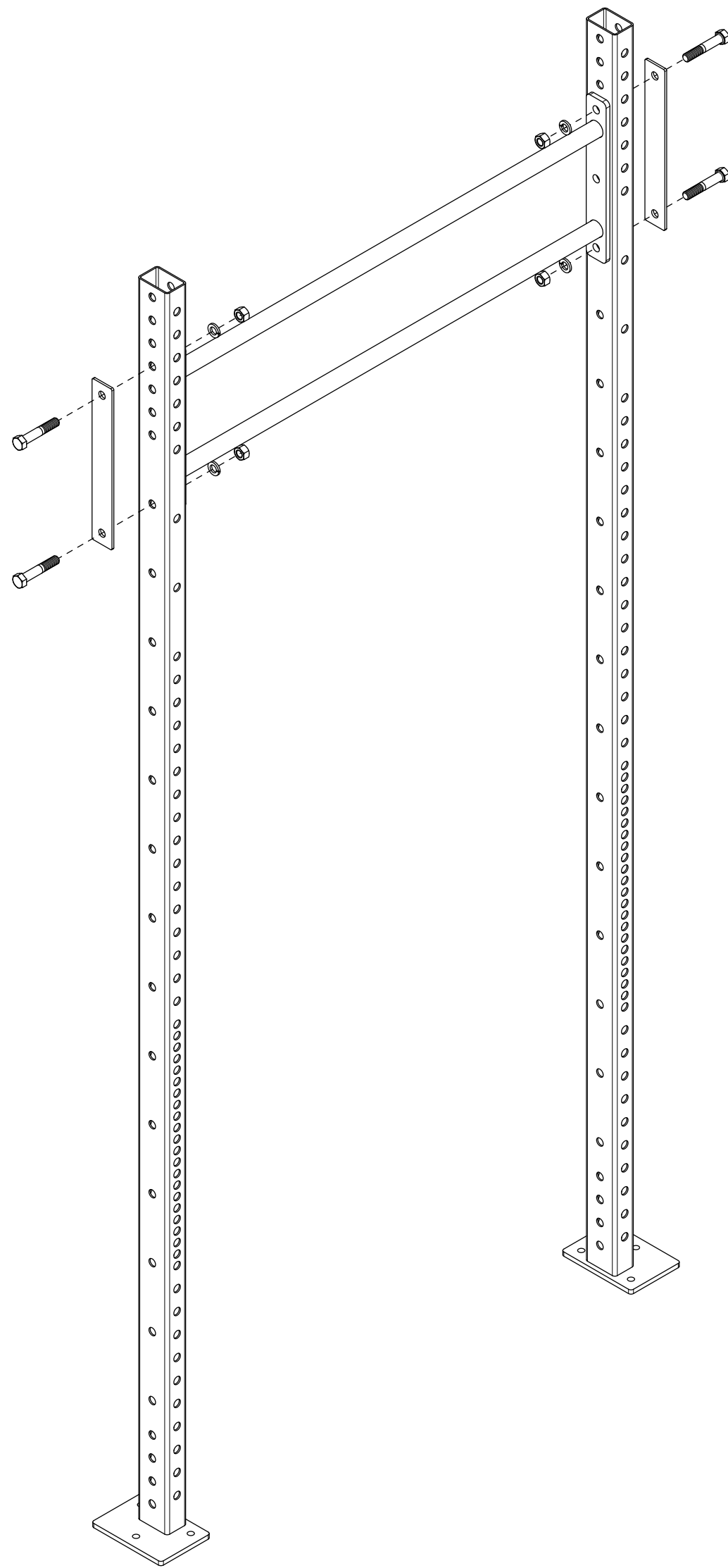

1-A

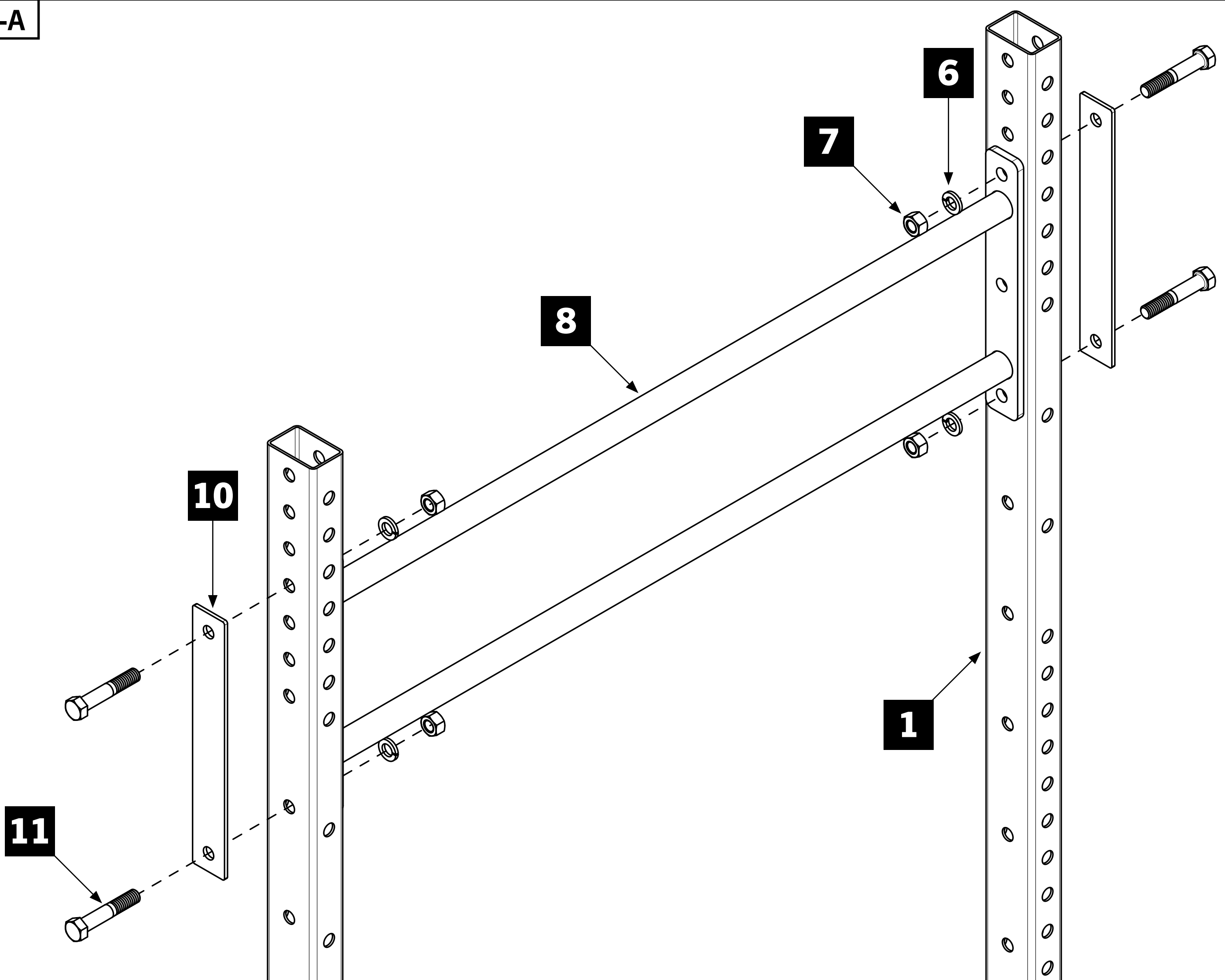

STEP 2

- Attach X-70 Parallel Crossmembers [9] to 108" SPX Rack Legs [1] using 5/8" x 4.5" Hex Screws [4], 5/8" Flat Washer [5], 5/8" Lock Washer [6], and 5/8" Hex Nut [7].

DETAIL

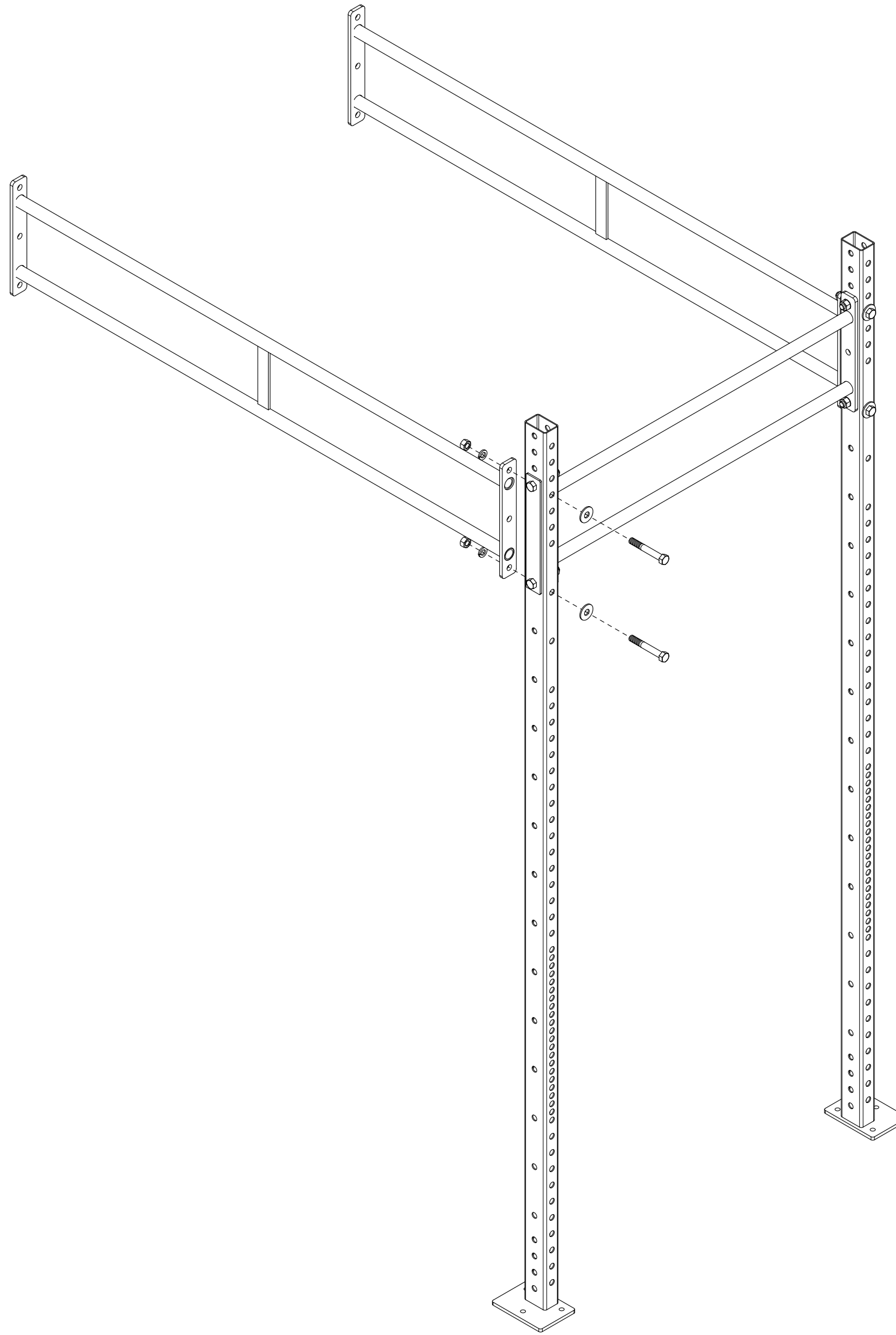

2-A

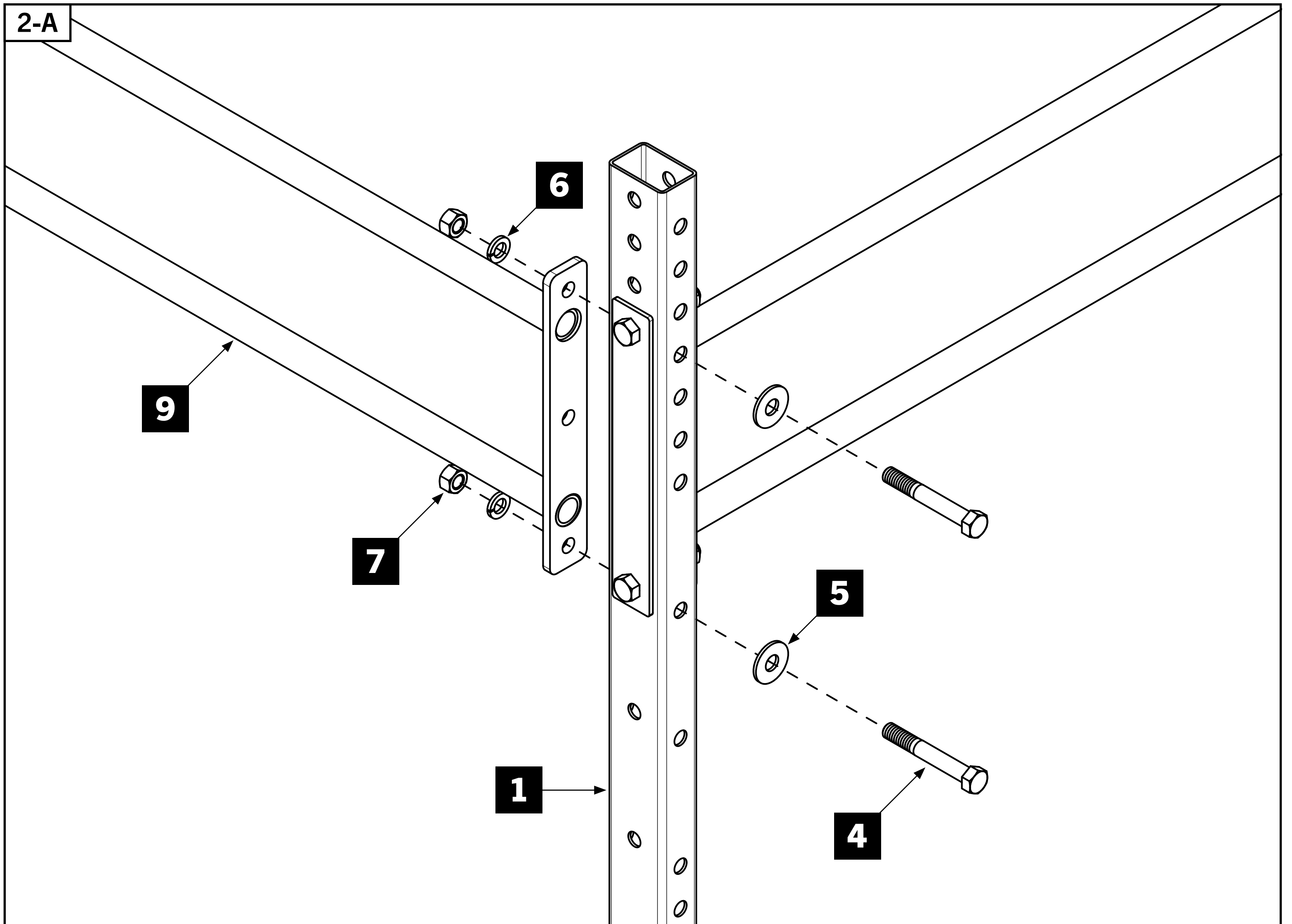

STEP 3

- Attach J Cup - LEFT and RIGHT to 108" SPX Rack Leg as shown in 3-A.
- Ensure each J Cup is securely attached before use.
- **FULLY TIGHTEN ALL HARDWARE.**
- Securely anchor the unit to the floor using the holes in the feet of the 108" SPX Rack Leg.

- If using rubber flooring, it is highly recommended to cut out a section so the feet anchor directly to the floor.

Anchor to wood or solid concrete floor:

- Wood: 3/8 x 3.5 Wood Lag Bolts
- Solid Concrete: 3/8" x 3.5" Concrete Wedge Anchors
- **Anchoring hardware not included.**

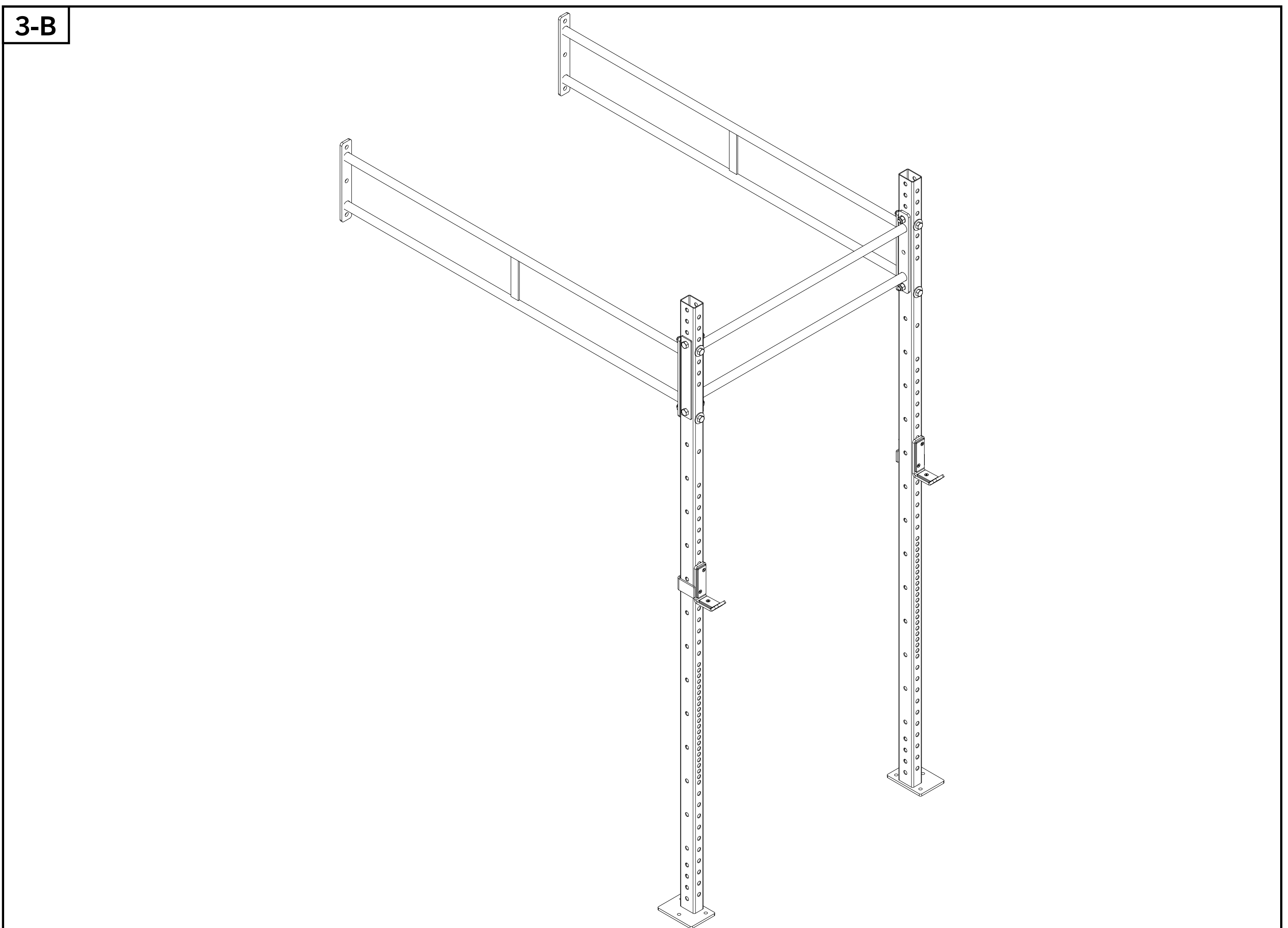
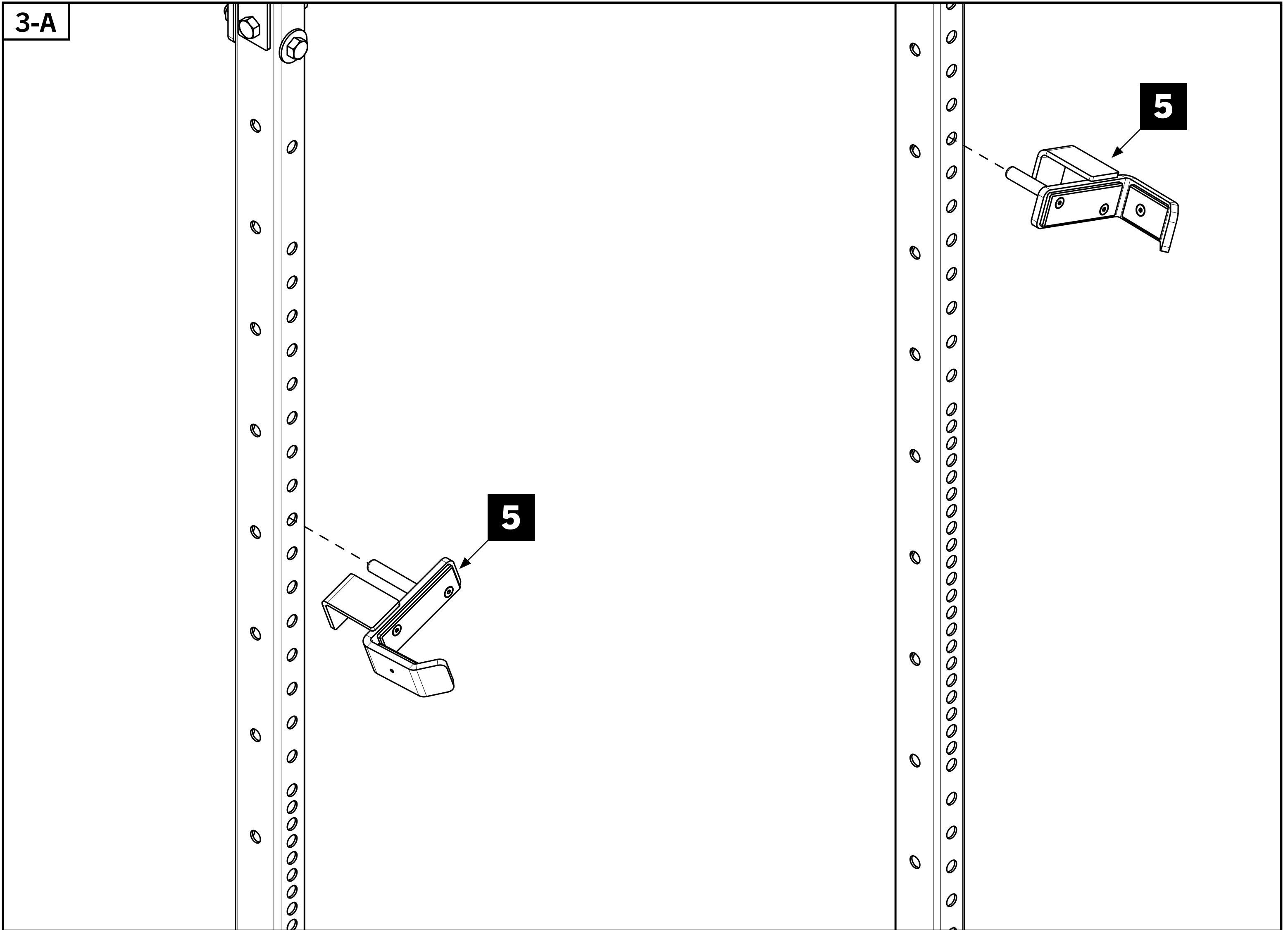

ROGUE



**SCAN FOR
INSTRUCTIONS**



**IRON GAME
PROGRAMMING**