

ROGUE®

RM-4 MONSTER RACK

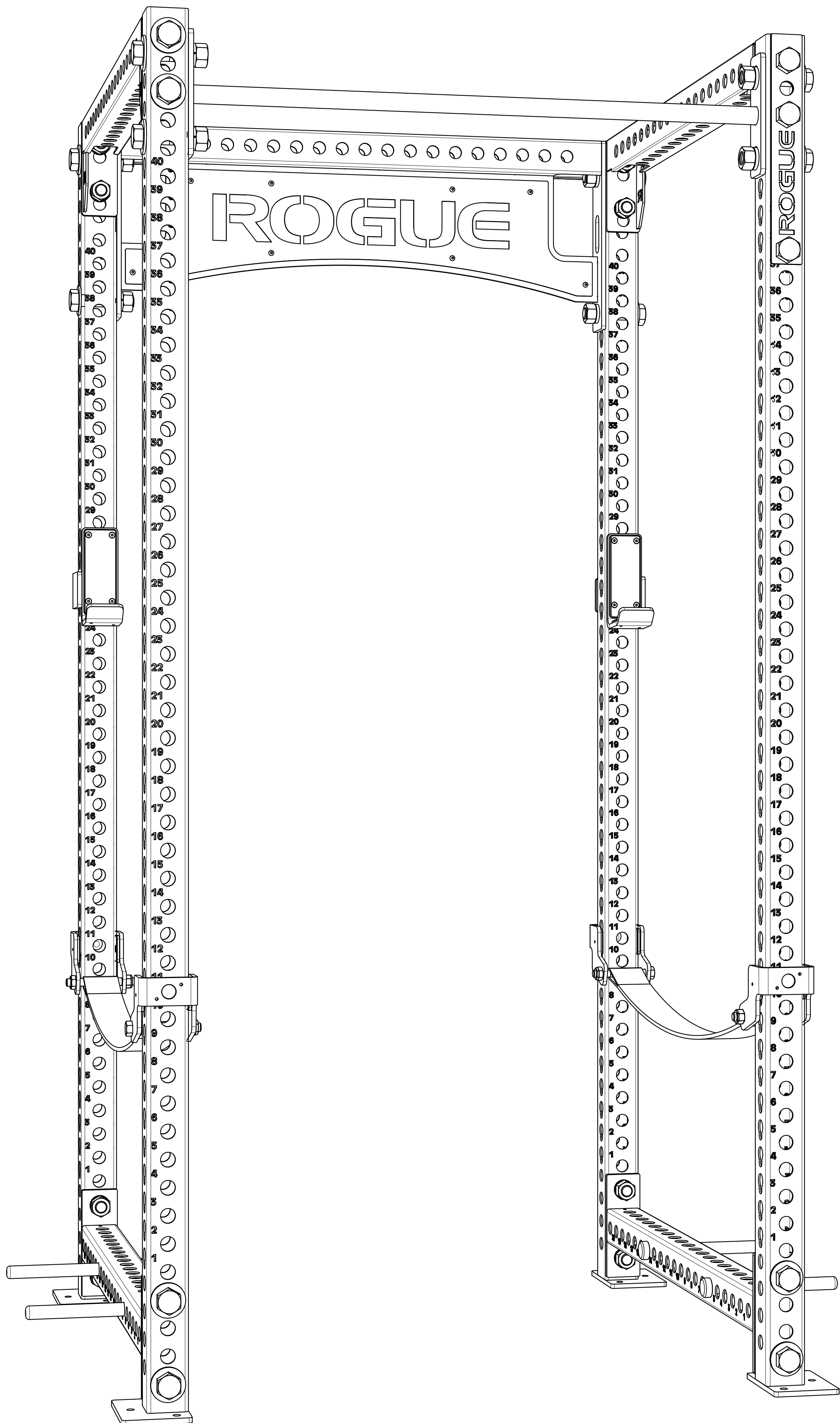

⚠ IMPORTANT SAFETY INFORMATION

DISCLAIMER:

Resistance training, gymnastics training, and activities at height are potentially dangerous and may lead to severe injury or even death. Use common sense when training, obtain instruction in the proper execution of movements, and understand your limitations. This equipment must only be used by competent and responsible persons. Obtaining instruction in appropriate techniques and methods of use is your own responsibility. You assume all risks and responsibilities for all damage, injury or death which may occur during or following incorrect use of this equipment in any matter whatsoever. Rogue Fitness bears no liability beyond the replacement value of the equipment in question.

WARNING:

MISUSE OF THIS PRODUCT CAN RESULT IN SEVERE INJURY. Both Rogue Fitness and buyer disclaim any express or implied warranty, including, without limitation, warranties or merchantability and/or fitness for a particular purpose with respect to the equipment. Buyer assumes all liability to use of equipment.

INCLUDED PARTS

Note: Images not shown at scale

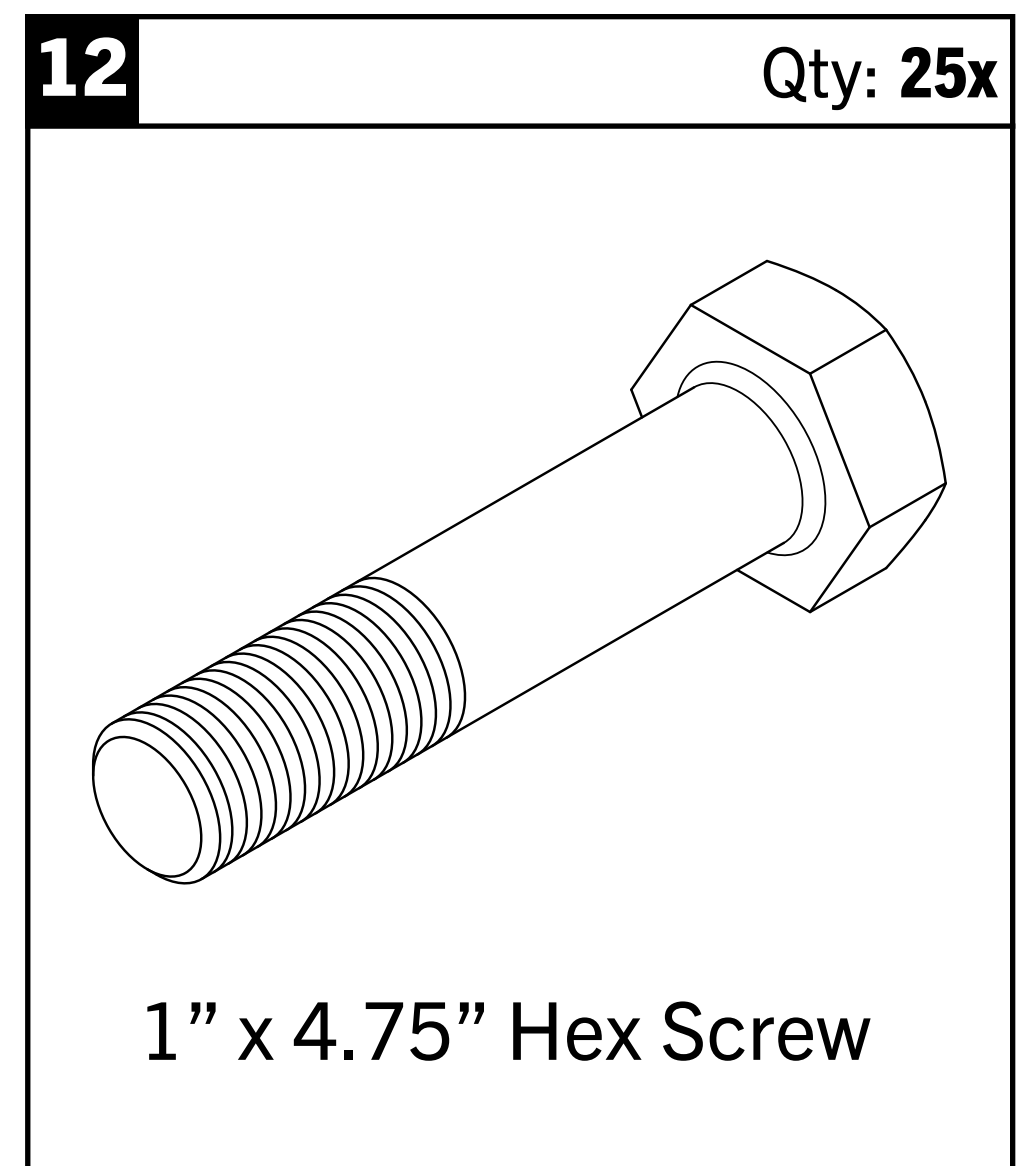
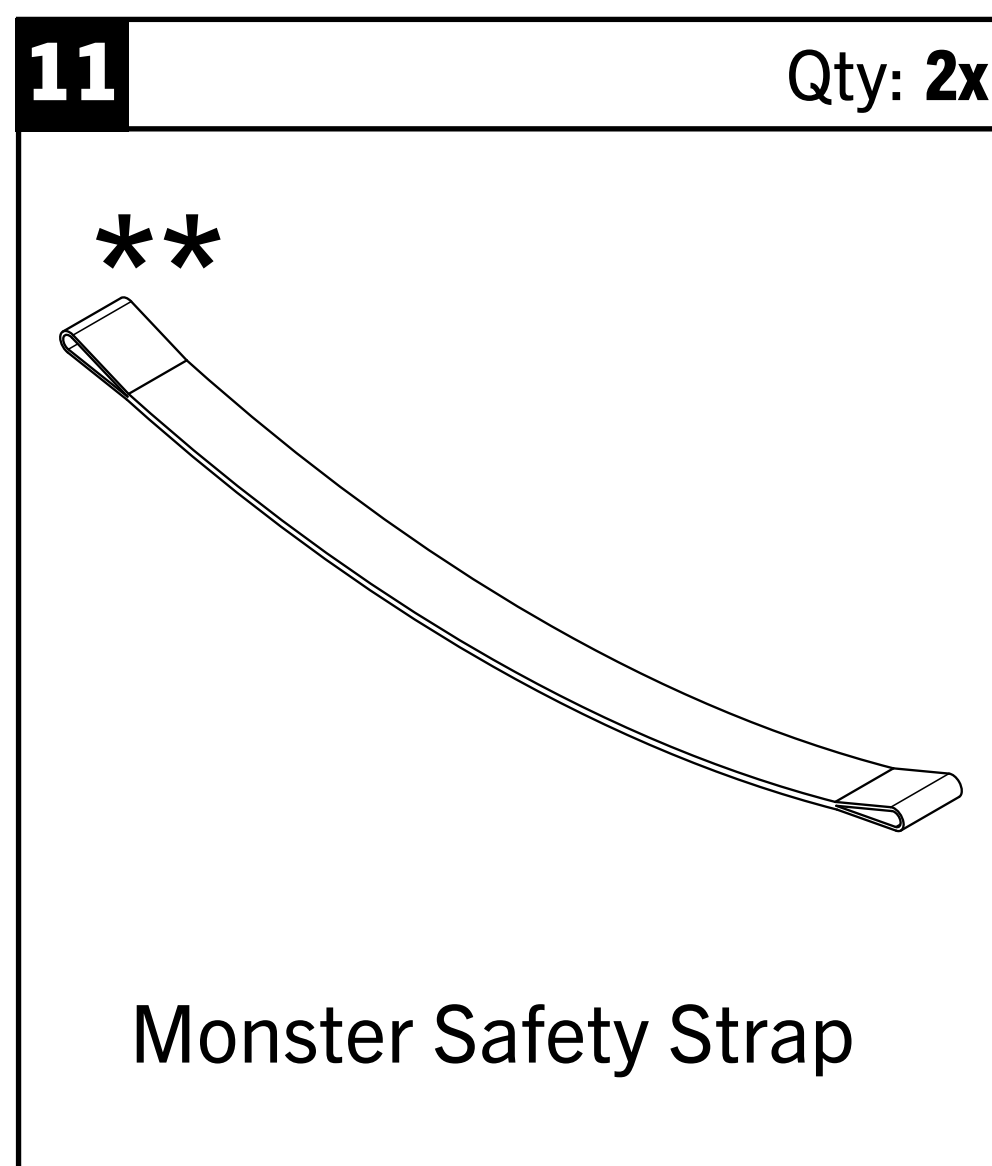
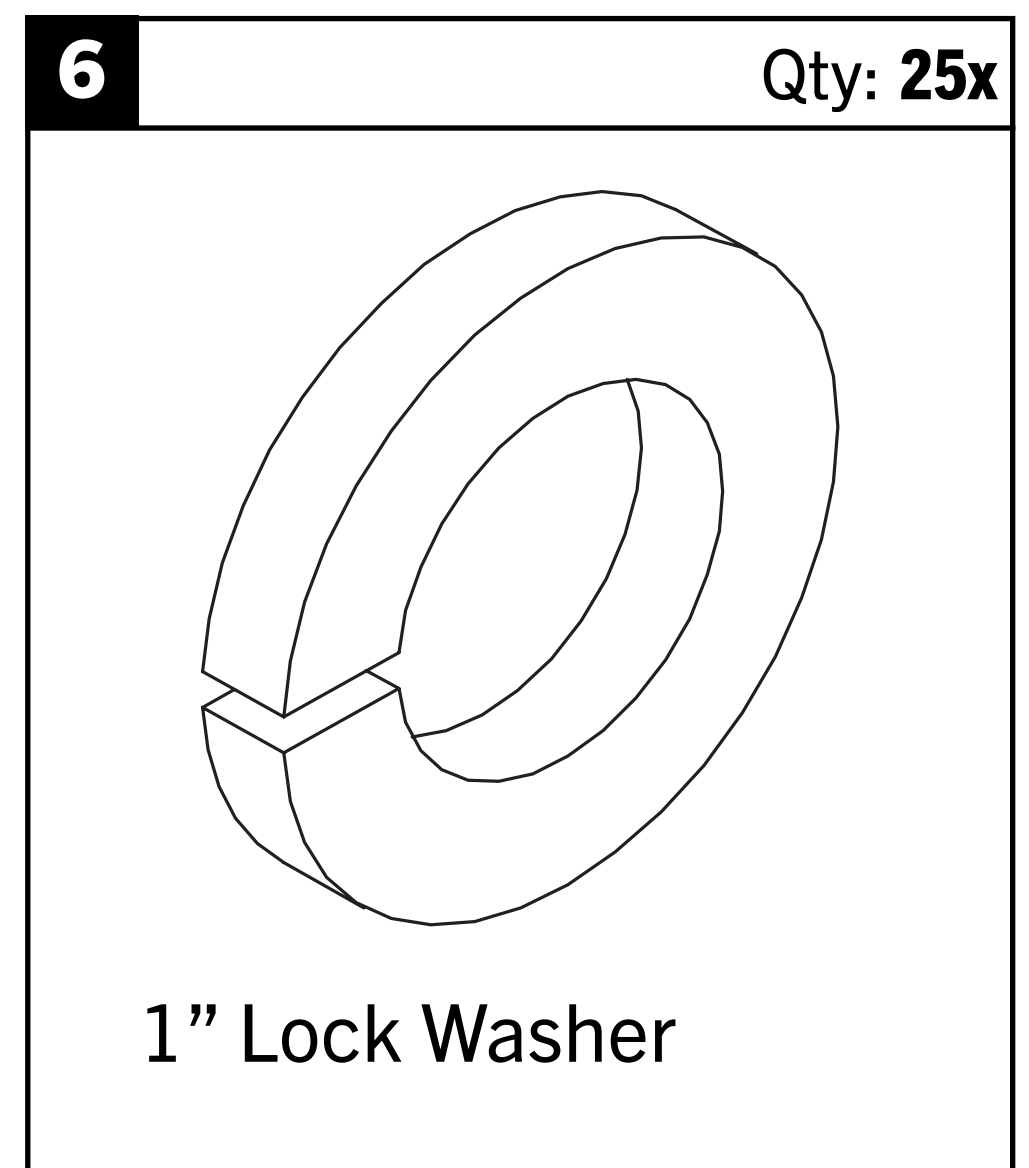
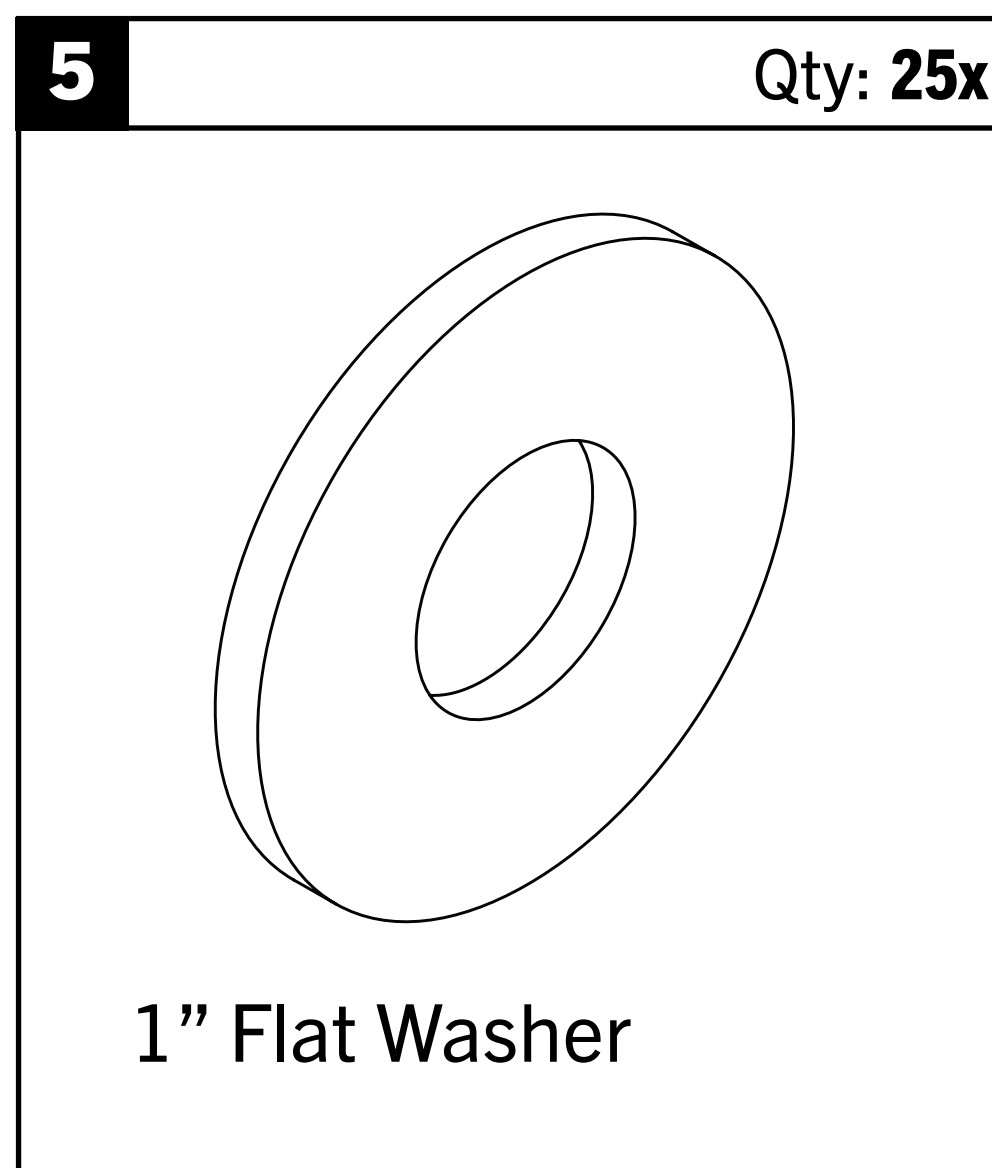
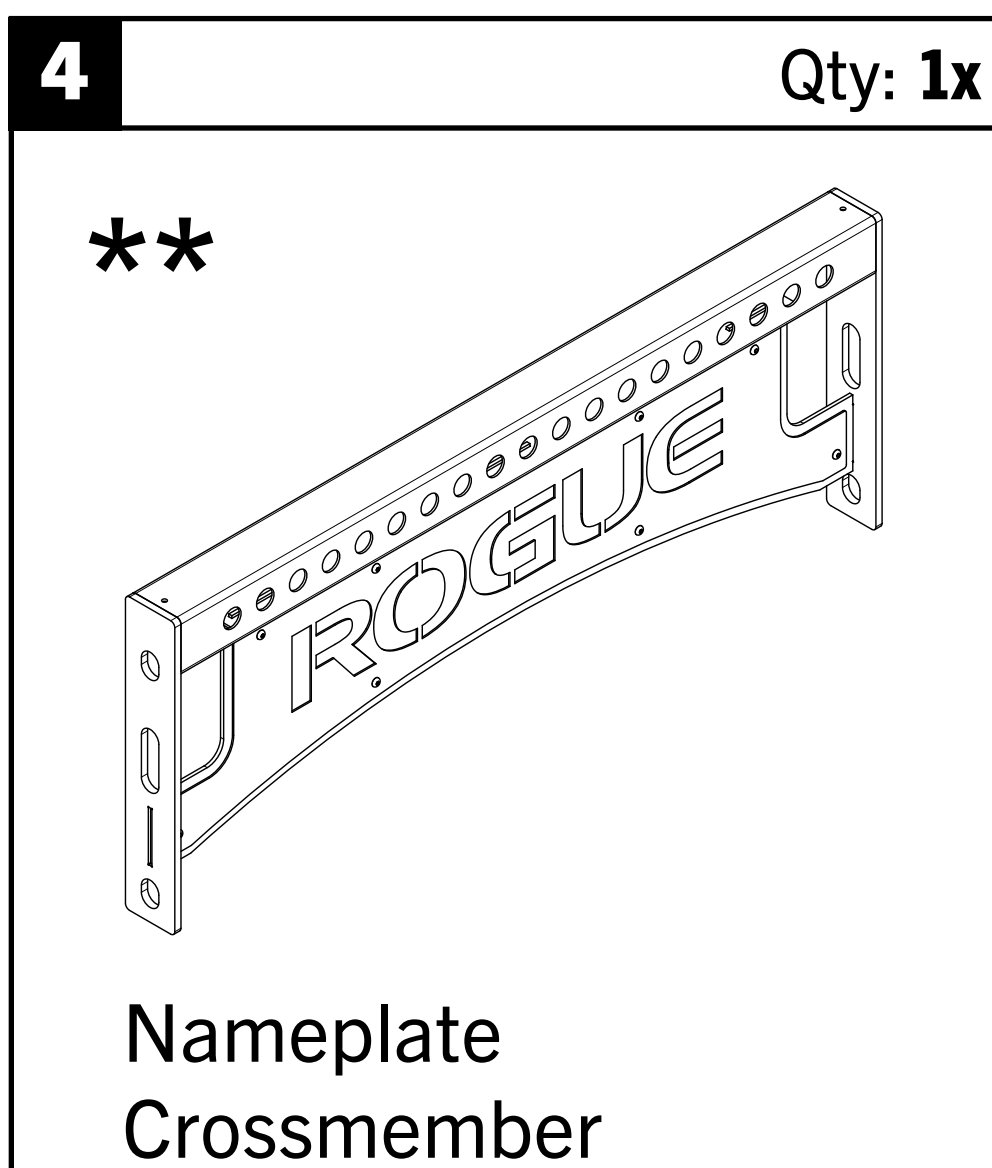
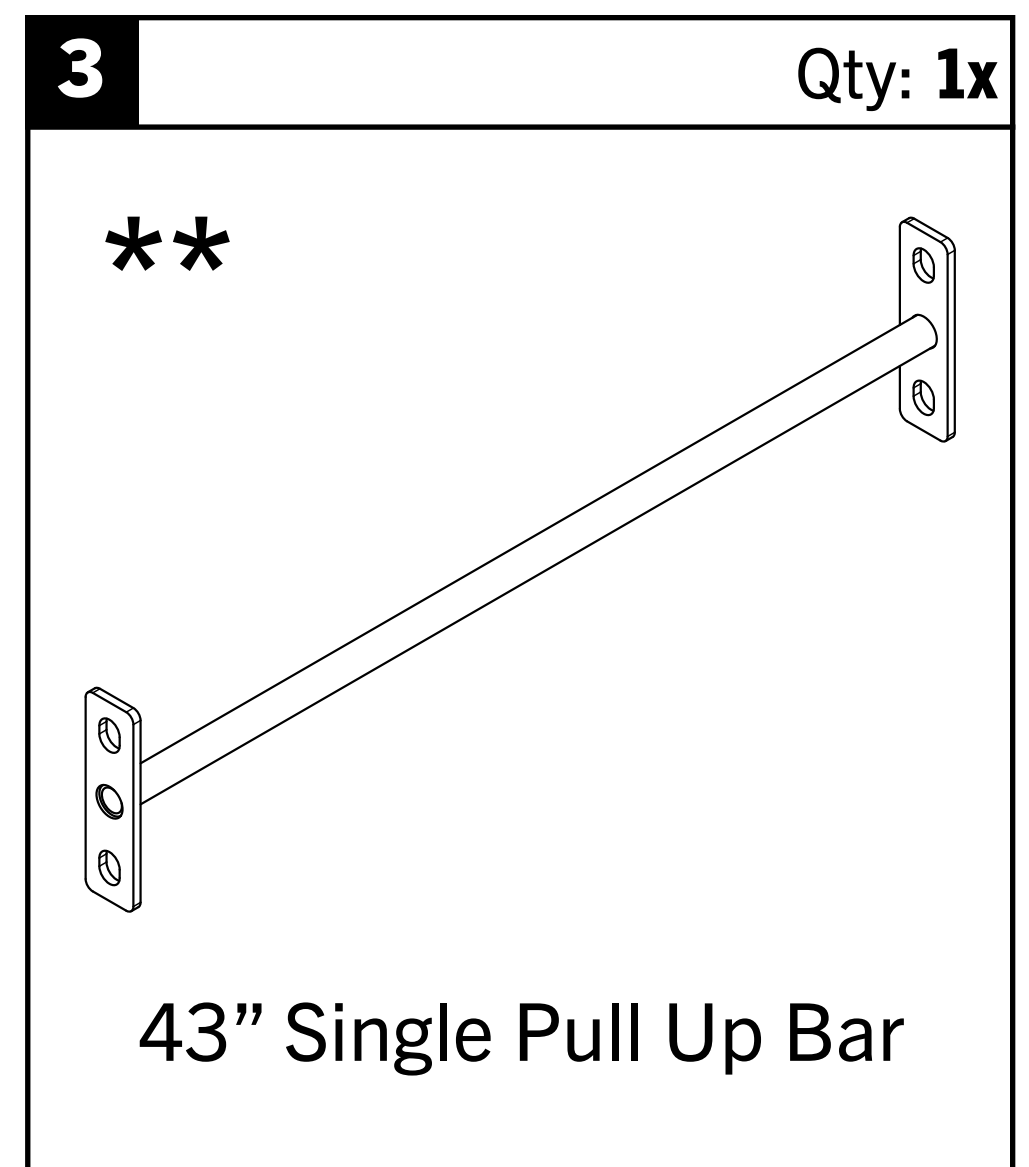
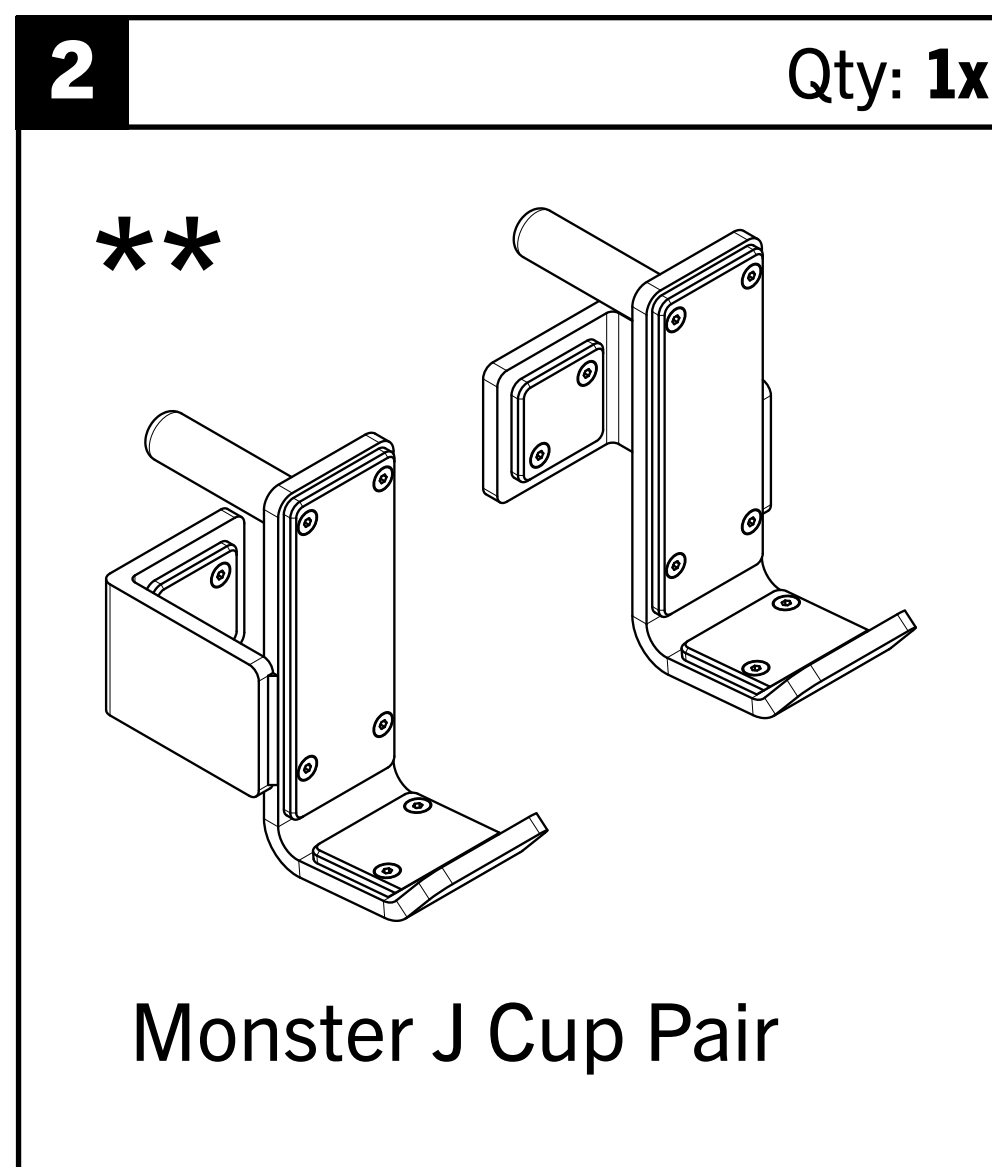
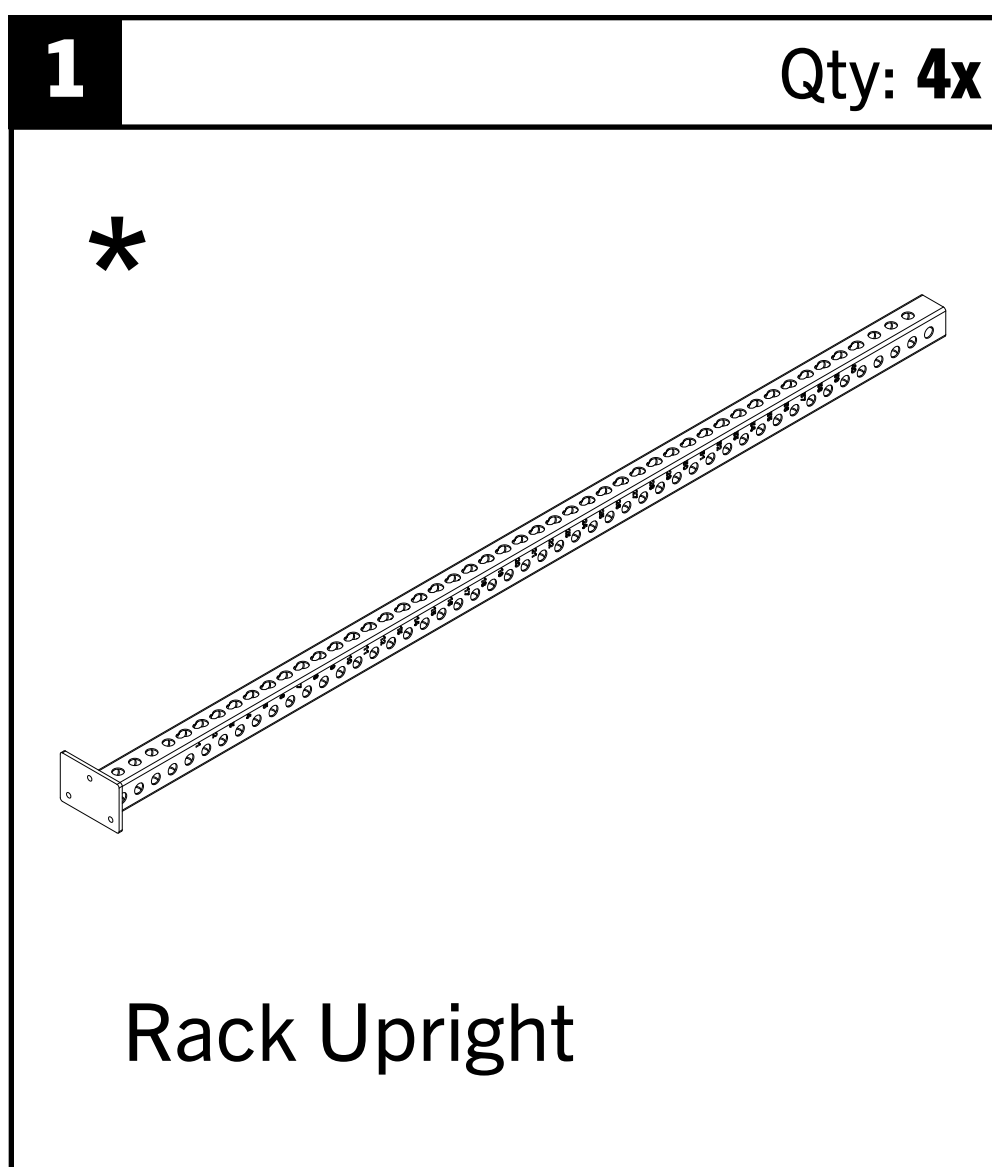

* Length depends on selection made at checkout.

** Product selection made at checkout.

INCLUDED PARTS

Note: Images not shown at scale

13 Qty: **4x**

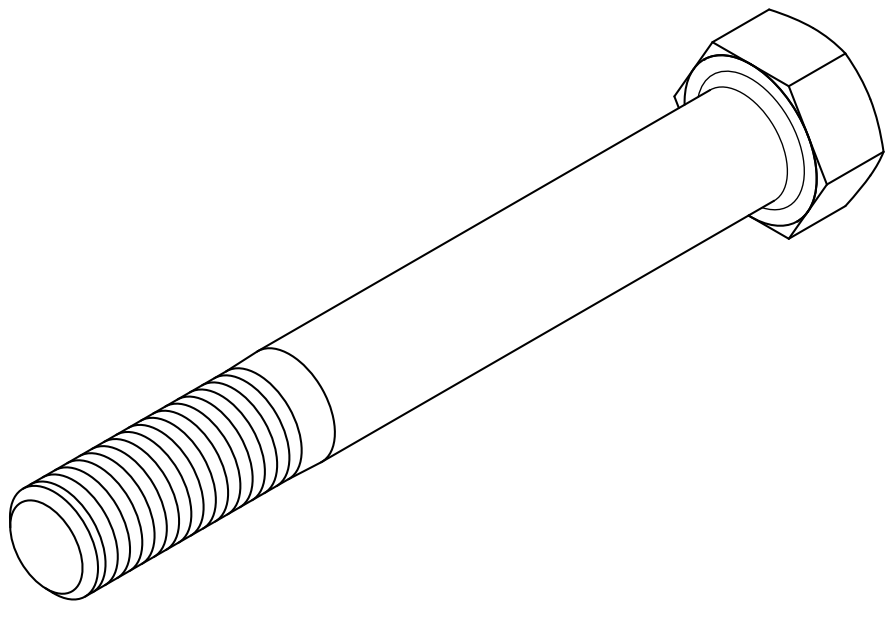

5/8" x 5" Hex Bolt

14 Qty: **2x**

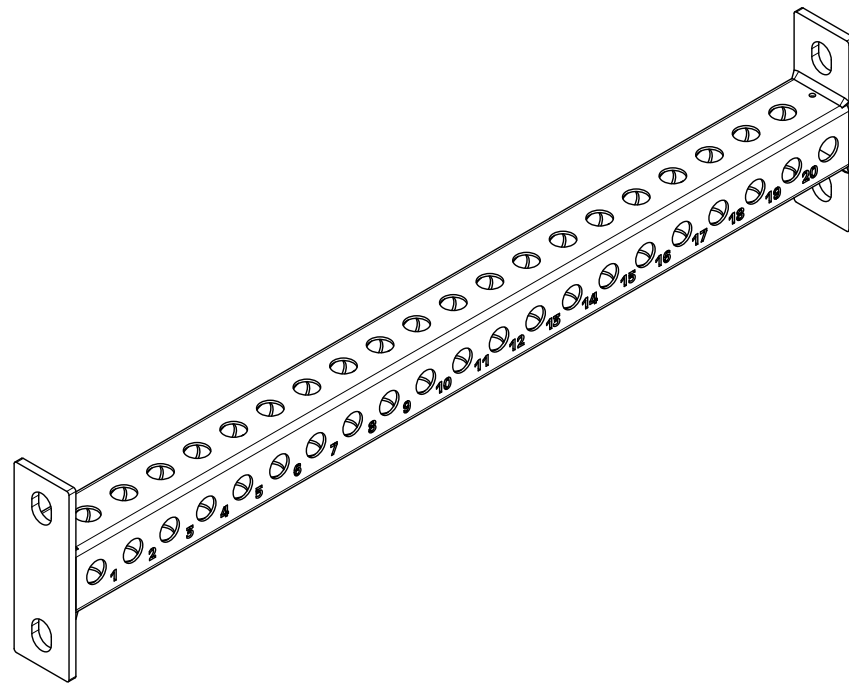

Monster 43" Bottom Crossmember

15 Qty: **2x**

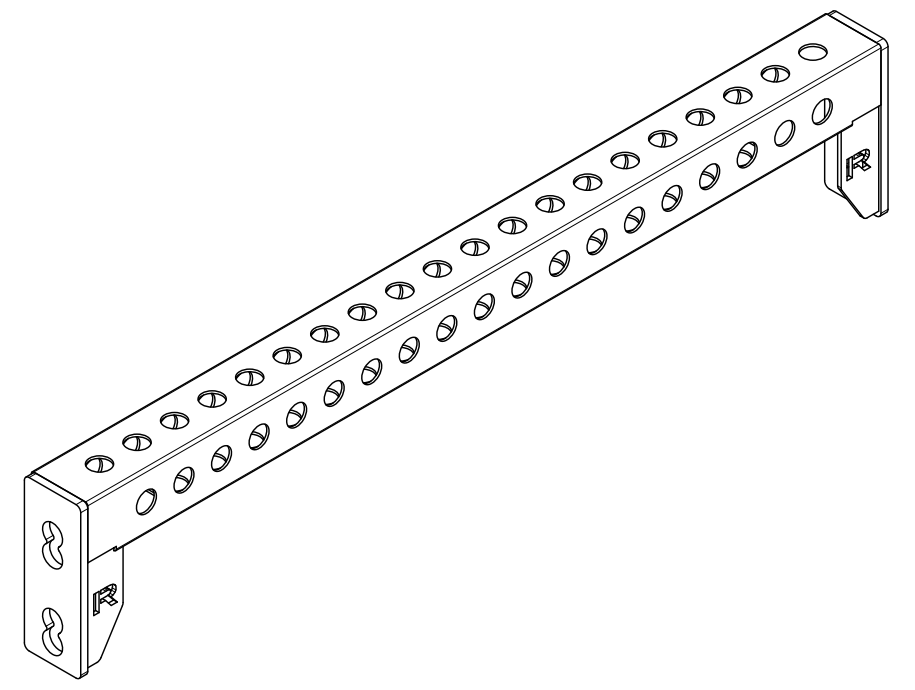

Monster 43" Top Crossmember

16 Qty: **1x**

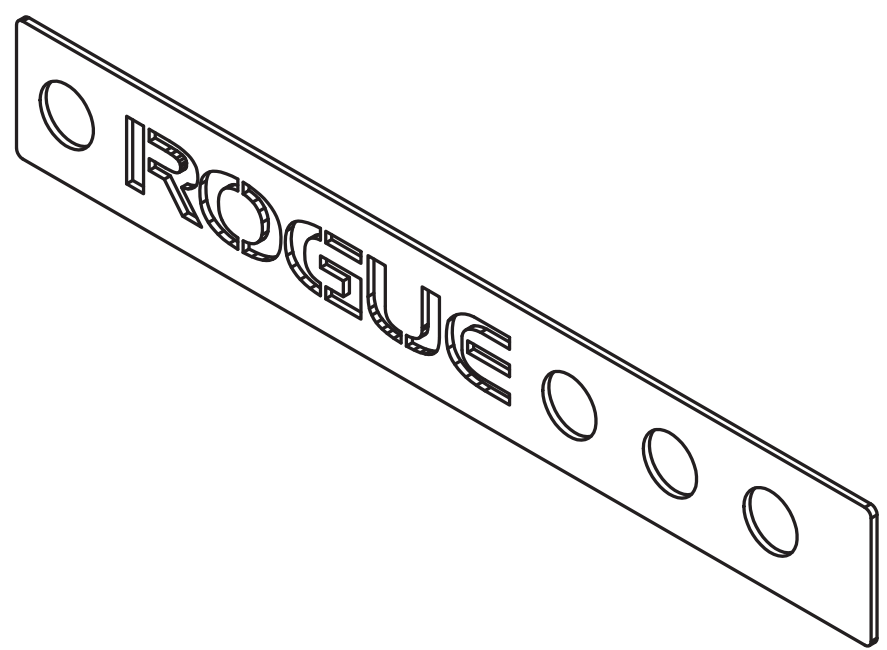

Branding Nameplate

17 Qty: **1x**

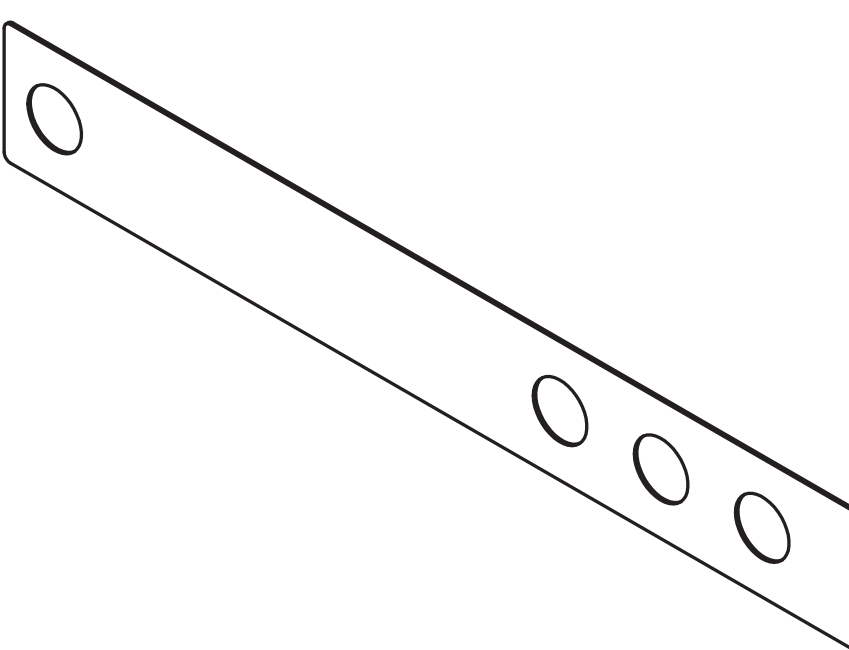

Branding Nameplate Backer

STEP 1

- Refer to overview image to plan assembly and ensure ample floor space is allotted.
- Lay down all parts on a non-abrasive surface in the orientation shown below.
- Position the footplates of uprights approximately 55" apart.
- Note orientation of Upright [1] feet in relation to the ground.
- Connect Uprights [1] to Crossmembers using 1"x 4.75" Hex Bolts [12], 1" Flat Washers [5], 1" Lock Washers [6], and 1" Hex Nuts [7].
- Attach Branding Nameplate [16], and Branding Nameplate Backer [17] to RH Panel using hardware as shown below.
- **HAND TIGHTEN ONLY.**

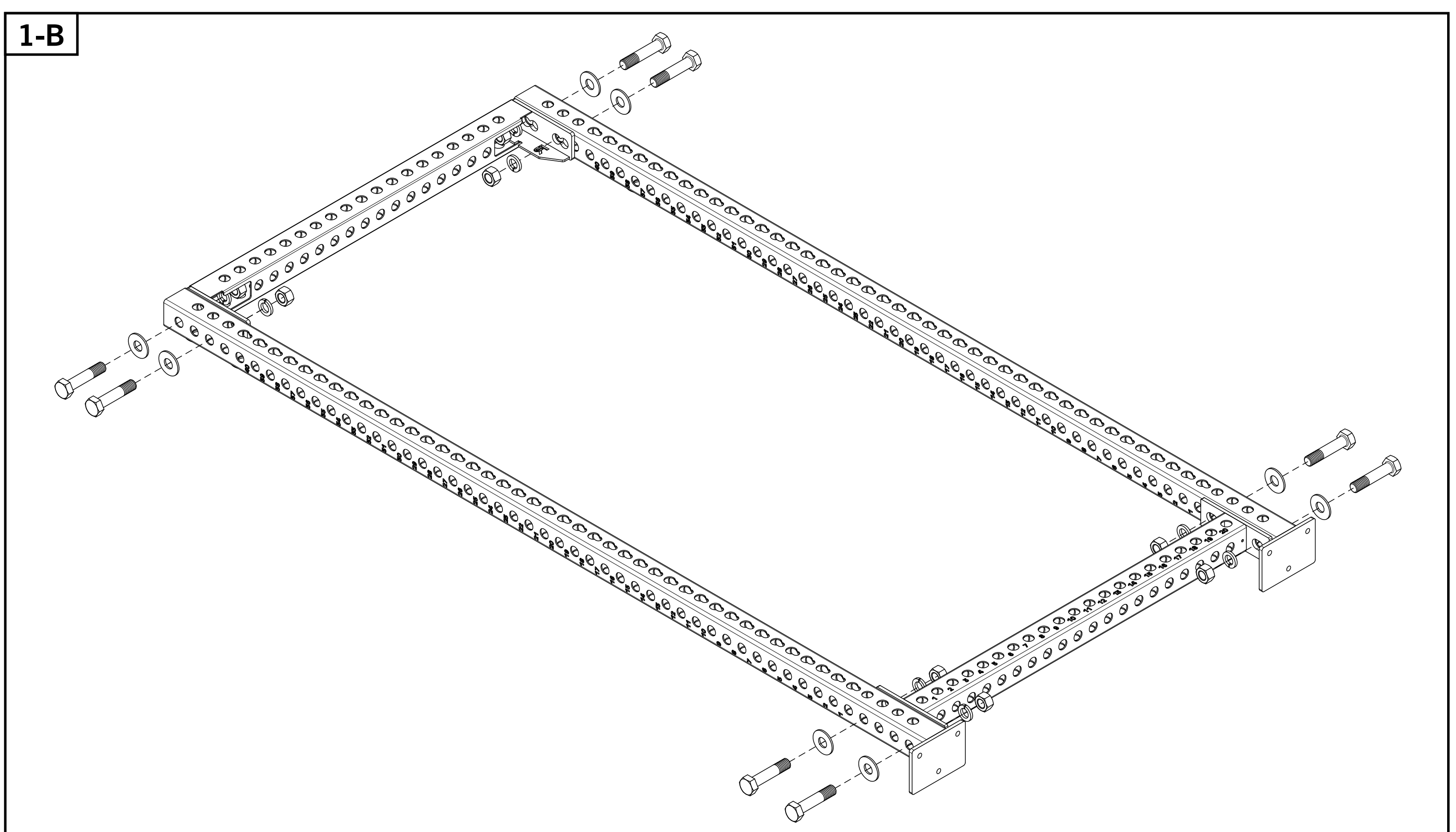
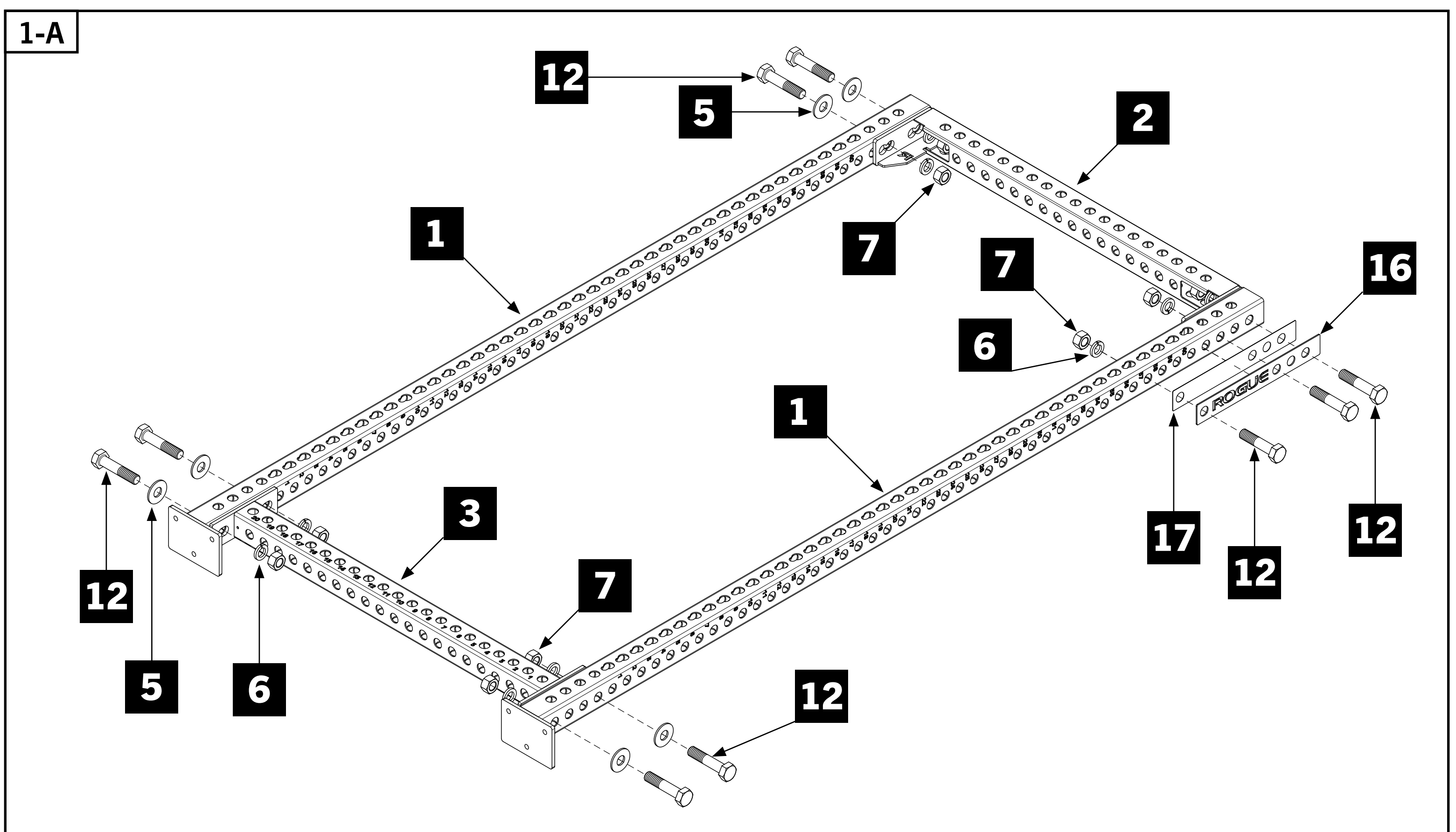
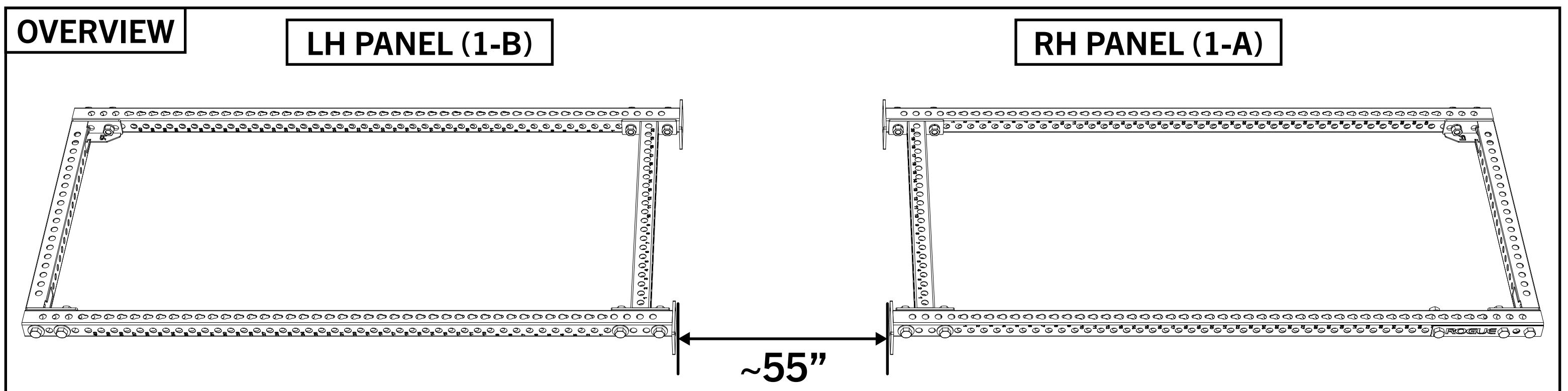

STEP 2

IMPORTANT:

- For safety, we recommend the remainder of these instructions be completed with **2 or 3 people**.
- Have two people stand one assembled panel up first.
- One person stabilizes the first panel while the other stands up the second panel.

- One or two people should stabilize both panels, ensuring panels don't fall while another person assembles the spanning Crossmembers in **STEP 3**.

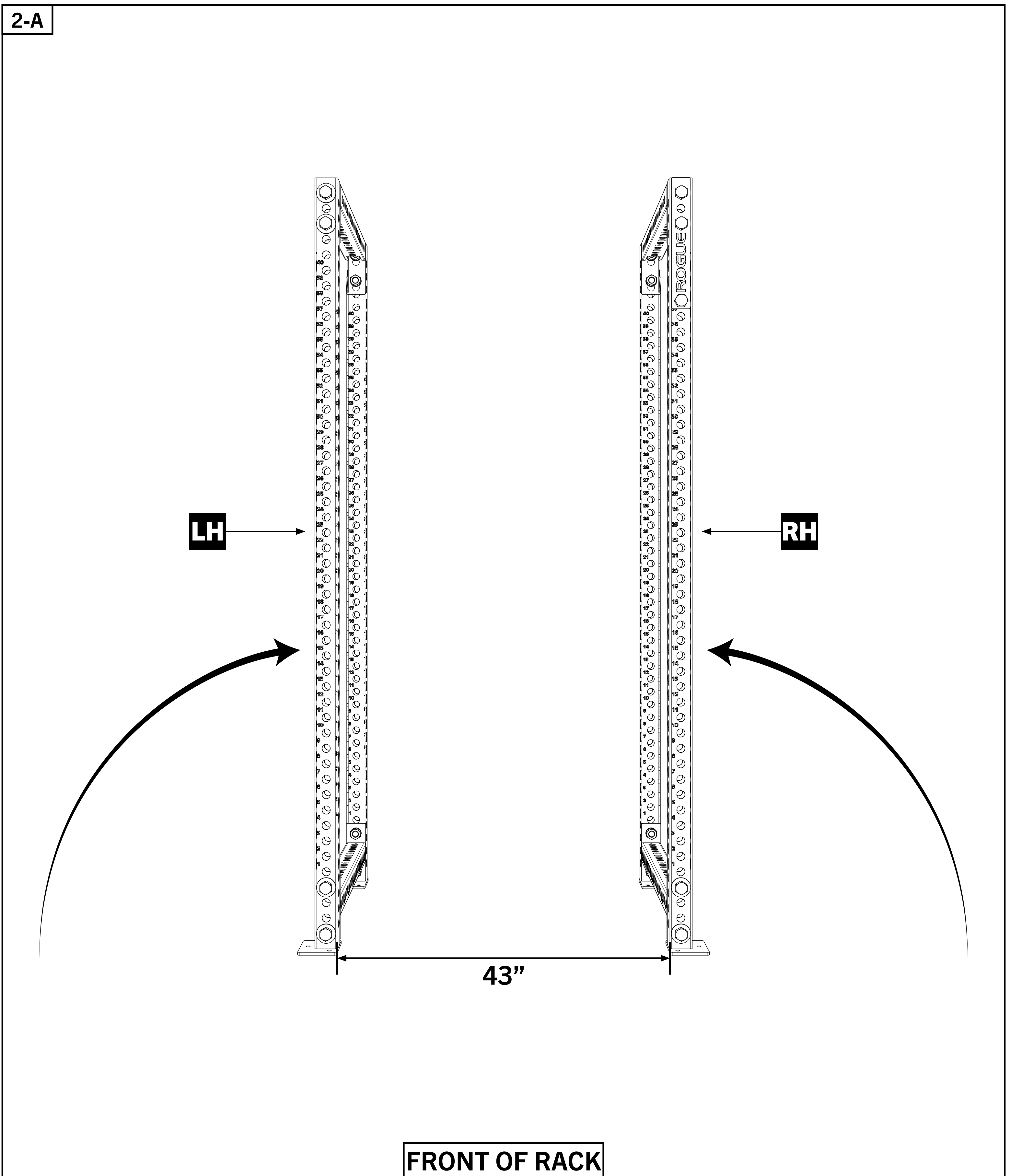
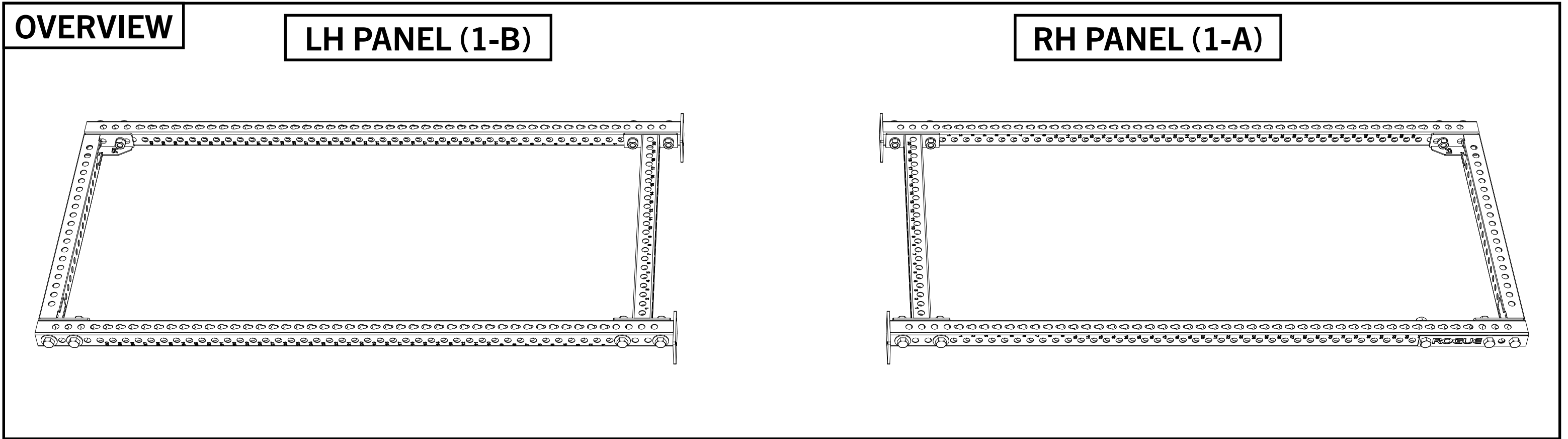

STEP 3

- Attach 43" Single Pull Up Bar [3] to Uprights [1] using 1" x 4.75" Hex Bolt [12], 1" Flat Washers [5], 1" Lock Washers [6], and 1" Hex Nuts [7].

- Attach Nameplate Crossmember to Rear Uprights using 1" x 4.75" Hex Bolt [12], 1" Flat Washers [5], 1" Lock Washers [6], and 1" Hex Nuts [7].

- **HAND TIGHTEN ONLY.**

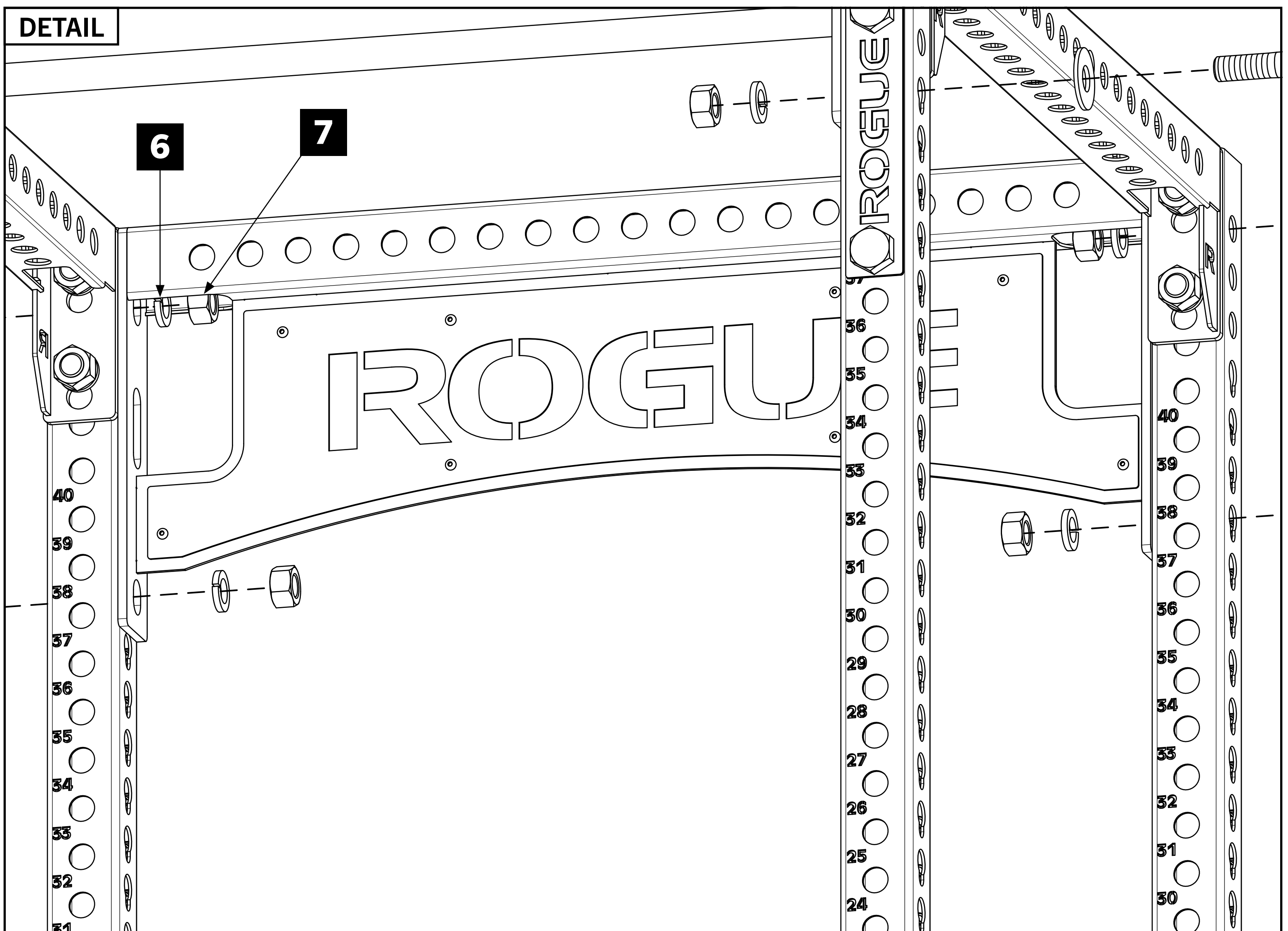
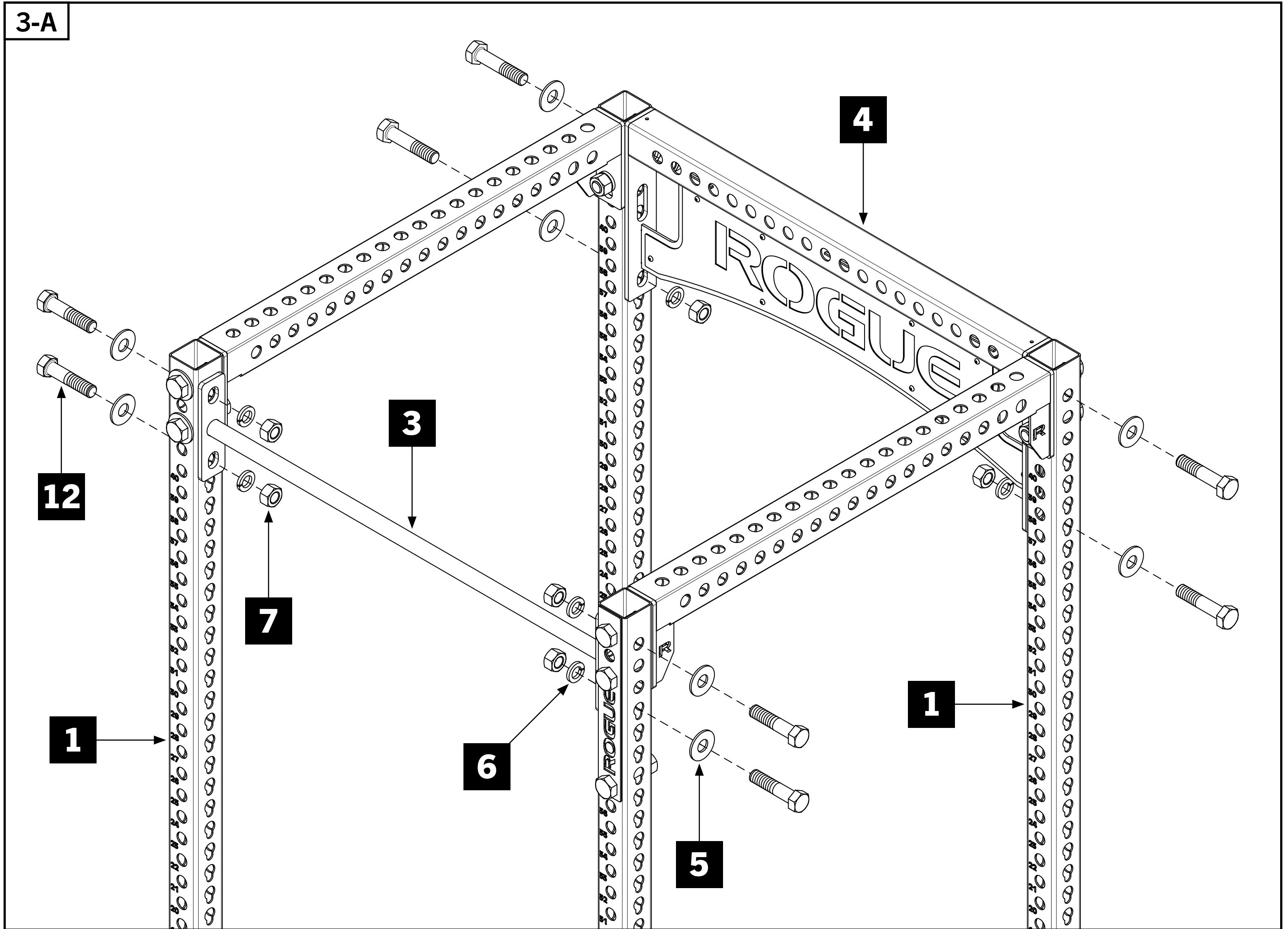

STEP 4

- Attach Monster J Cup Pair [2] to rear Rack Uprights [1] as shown in 4-A.
- Ensure each J Cup is securely attached before use.

- Insert Band Peg [9] into Monster 43" Bottom Crossmembers [14] as shown in 4-B.
- Do not fully tighten hardware until the entire rack is assembled. This will ensure that the rack sits level to the floor.
- Do not bolt rack to the floor until it is fully assembled and all hardware is tightened.

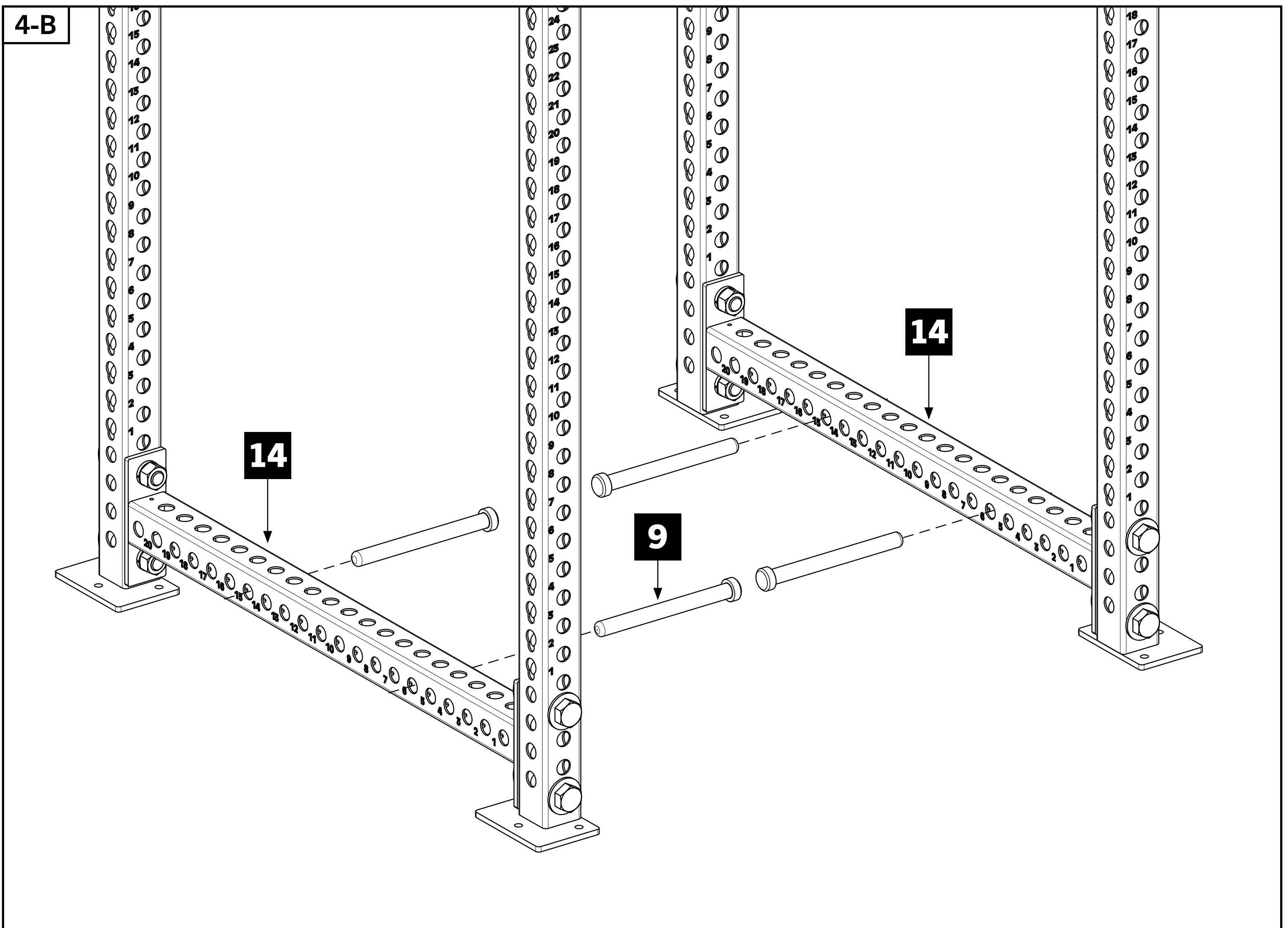
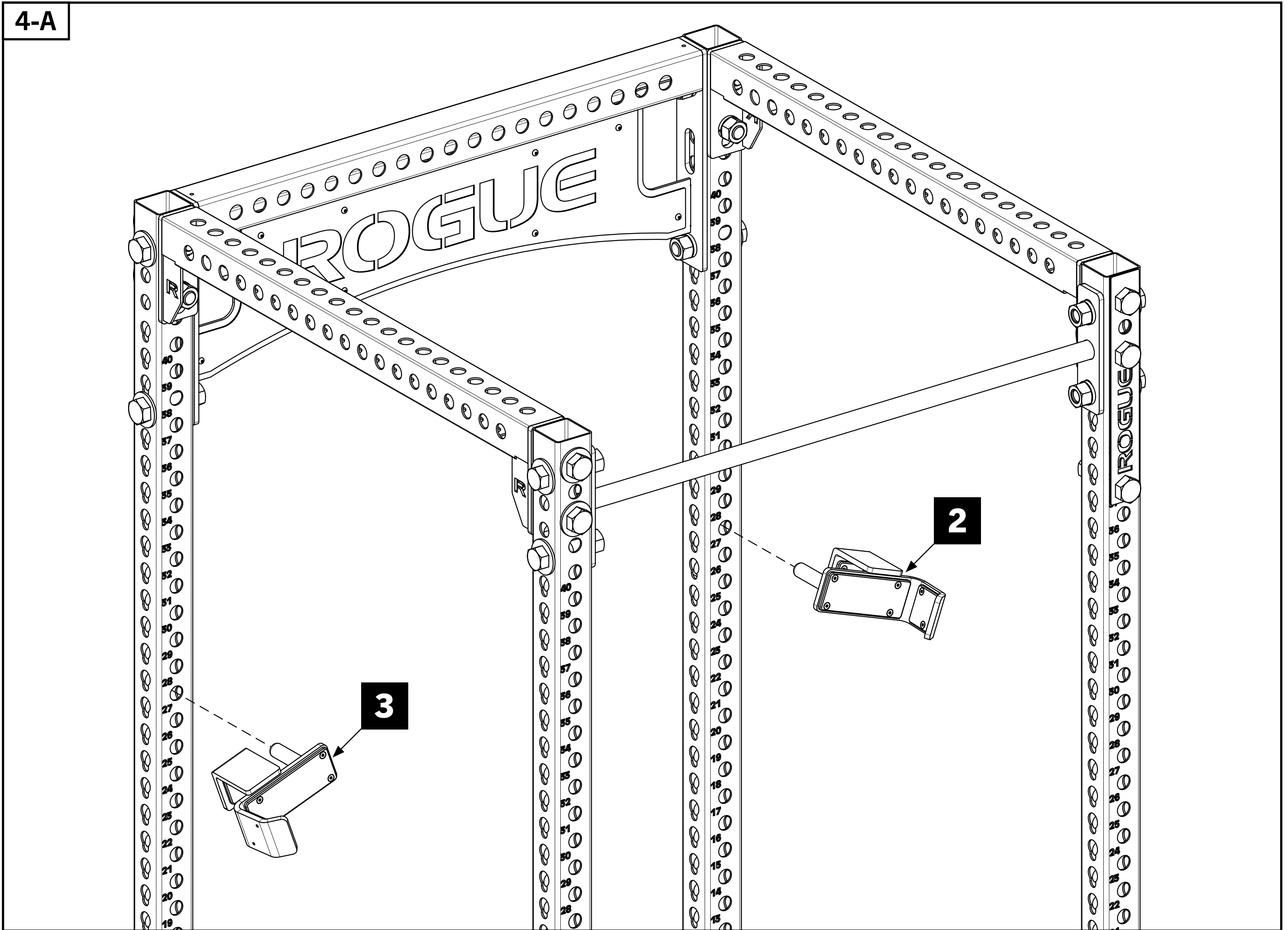

STEP 5

- Attach the Monster Safety Strap Hanger 2.0 [10] to each Rack Upright [1] by inserting the pin into a hole on the upright at the desired position.
- Ensure that pin notch on Monster Safety Strap Hanger 2.0 [10] is fully seated onto Upright tube wall opening.
- Attach Monster Safety Strap [11] to Monster Safety Strap Hanger 2.0 [10] using 5/8" x 5" Hex Bolt [13] and 5/8" Nylock Hex Nut [8].
- **FULLY TIGHTEN ALL HARDWARE.**

- Securely anchor the unit to the floor using the holes in the feet of the Rack Uprights [1].
- If using rubber flooring, it is highly recommended to cut out a section so the feet anchor directly to the floor.

Anchor to wood or solid concrete floor:

- Wood: 3/8 x 3.5 Wood Lag Bolts
- Solid Concrete: 3/8" x 3.5" Concrete Anchors
- **Anchoring hardware not included.**

5-A

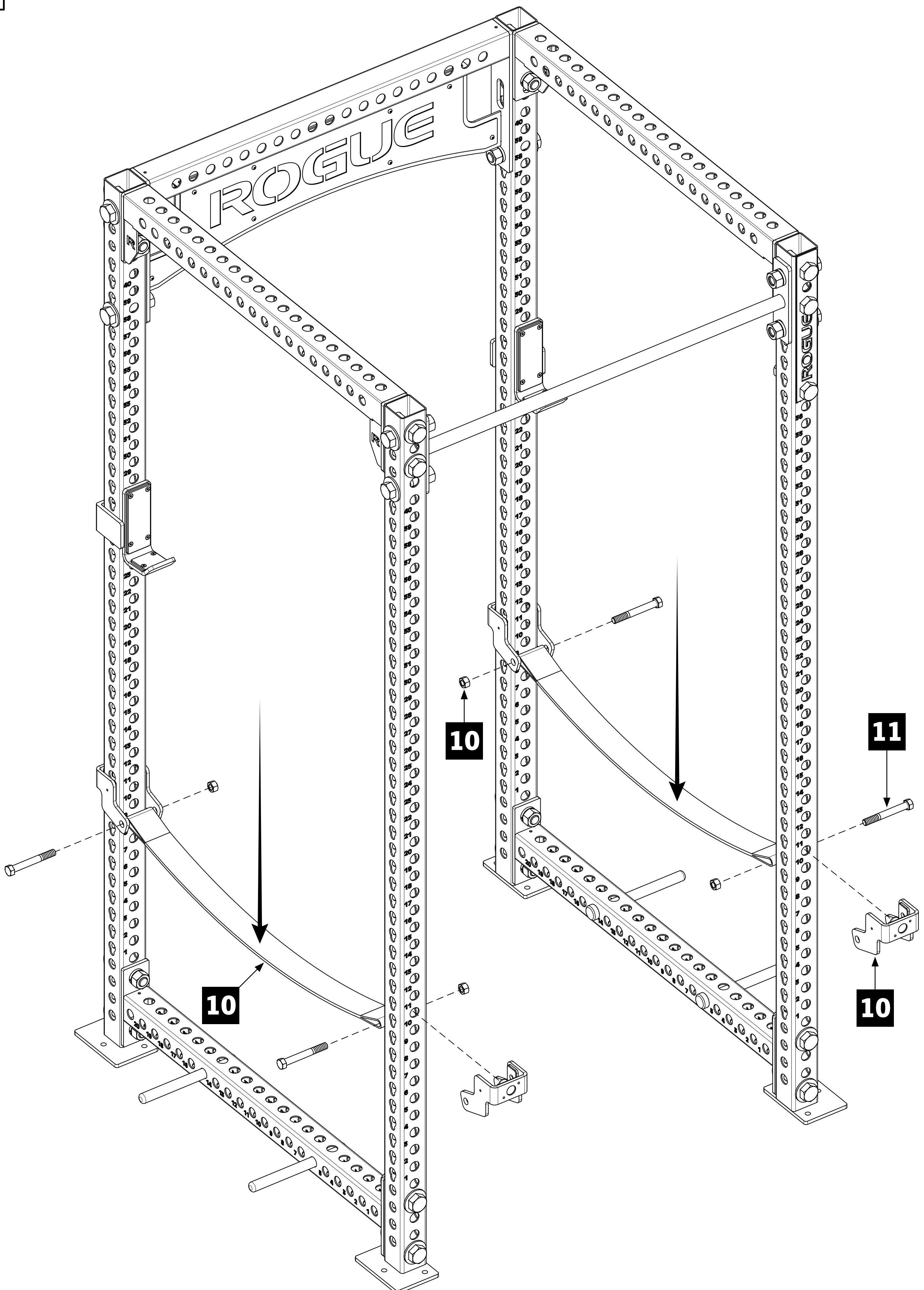

ROGUE



**SCAN FOR
INSTRUCTIONS**



**IRON GAME
PROGRAMMING**