

ROGUE OLY PLATFORM

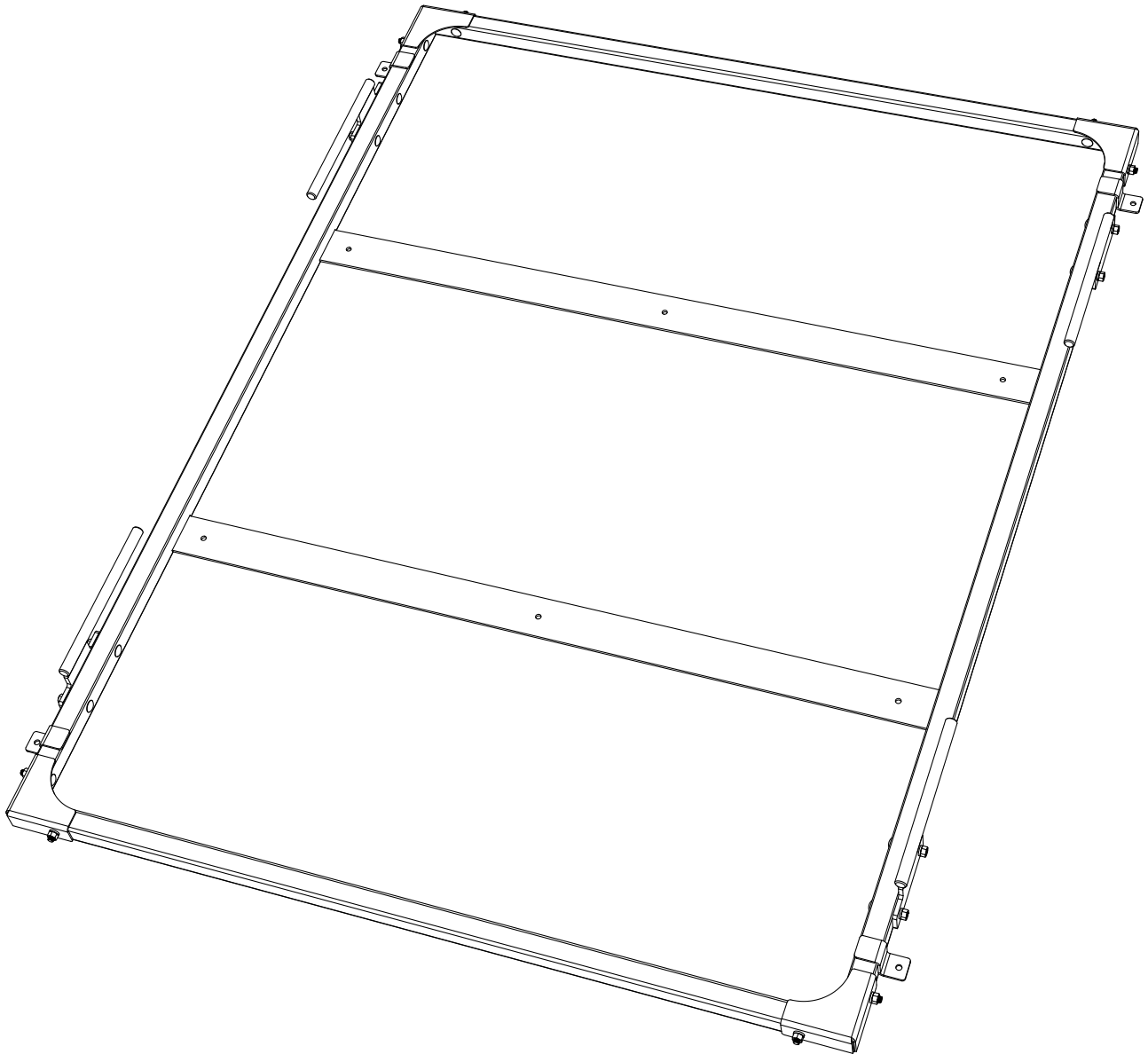

*Shown with optional Band Peg set and Floor Plate set

INSTRUCTIONS AND ASSEMBLY

ROGUE[®]

Rogue Fitness • 545 E 5th Ave. Columbus, Ohio 43201 • Customer Service: 614-358-6190 • Team@RogueFitness.com

GENERAL GUIDELINES

- Please read these customer instructions thoroughly prior to assembling.

TOOLS REQUIRED

Note: Images not shown at scale

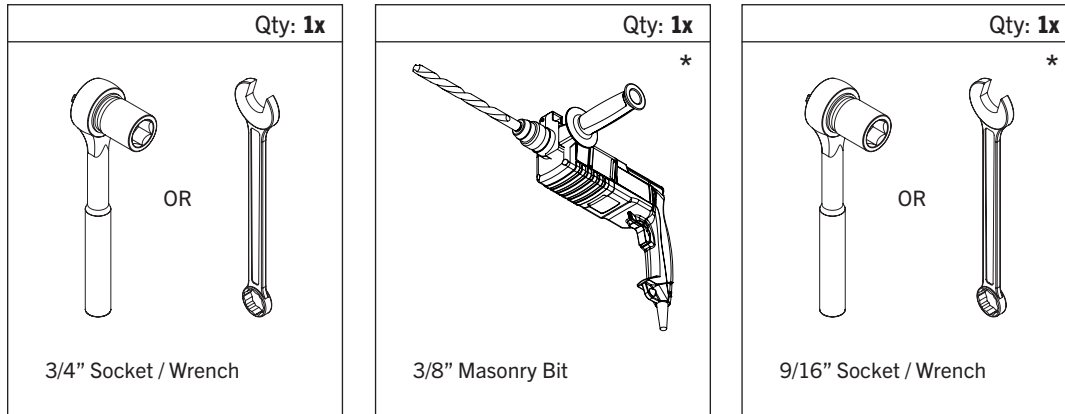

* Only needed if bolting unit to floor for banded work. A hammer drill is highly recommended.



IMPORTANT SAFETY INFORMATION

DISCLAIMER:

Resistance training, gymnastics training, and activities at height are potentially dangerous and may lead to severe injury or even death. Use common sense when training, obtain instruction in the proper execution of movements, and understand your limitations. This equipment must only be used by competent and responsible persons. Obtaining instruction in appropriate techniques and methods of use is your own responsibility. You assume all risks and responsibilities for all damage, injury or death which may occur during or following incorrect use of this equipment in any matter whatsoever. Rogue Fitness bears no liability beyond the replacement value of the equipment in question.

WARNING:

MISUSE OF THIS CAN RESULT IN SEVERE INJURY.

Both Rogue Fitness and buyer disclaim any express or implied warranty, including, without limitation, warranties or merchantability and/or fitness for a particular purpose with respect to the equipment. Buyer assumes all liability to use of equipment.

INCLUDED PARTS

Note: Images not shown at scale

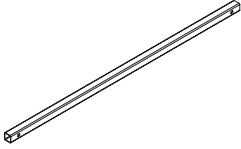
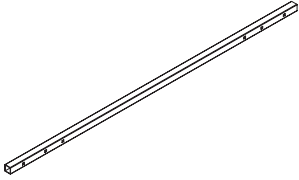
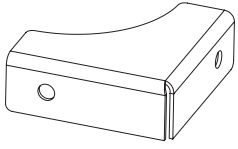
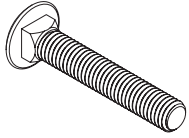
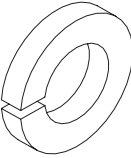
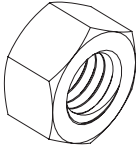
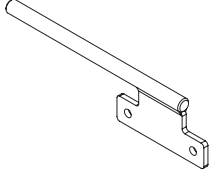
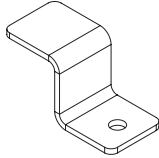
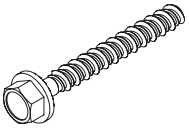
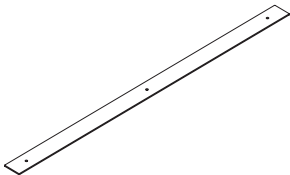
<p>1 Qty: 2x</p>  <p>72" Short Frame Tube</p>	<p>2 Qty: 2x</p>  <p>100" Long Frame Tube</p>	<p>3 Qty: 4x</p>  <p>Corner Bracket</p>	<p>4 Qty: 8x *16x</p>  <p>1/2" x 3" Carriage Bolt</p>
<p>5 Qty: 8x *16x</p>  <p>1/2" Lock Washer</p>	<p>6 Qty: 8x *16x</p>  <p>1/2" Hex Nut</p>	<p>7 Qty: 4x *</p>  <p>Band Peg</p>	<p>8 Qty: 4x *</p>  <p>Bolt-Down Bracket</p>
<p>9 Qty: 4x *</p>  <p>3/8" HD Concrete Anchor</p>	<p>10 Qty: 2x **</p>  <p>Floor Plate</p>		

* Included in optional Band Peg set. Additional 8x carriage bolts, lock washers, and nuts also included in Band Peg set.

** Included in optional Floor Plate set.

STEP 1

Tools Required:

- None

Note:

- If optional Floor Plates **10** were purchased, skip **STEP 1** and proceed to **STEP 2**.
- Lay out 72" Short **1** and 100" Long Frame Tubes **2** and position them as shown below.

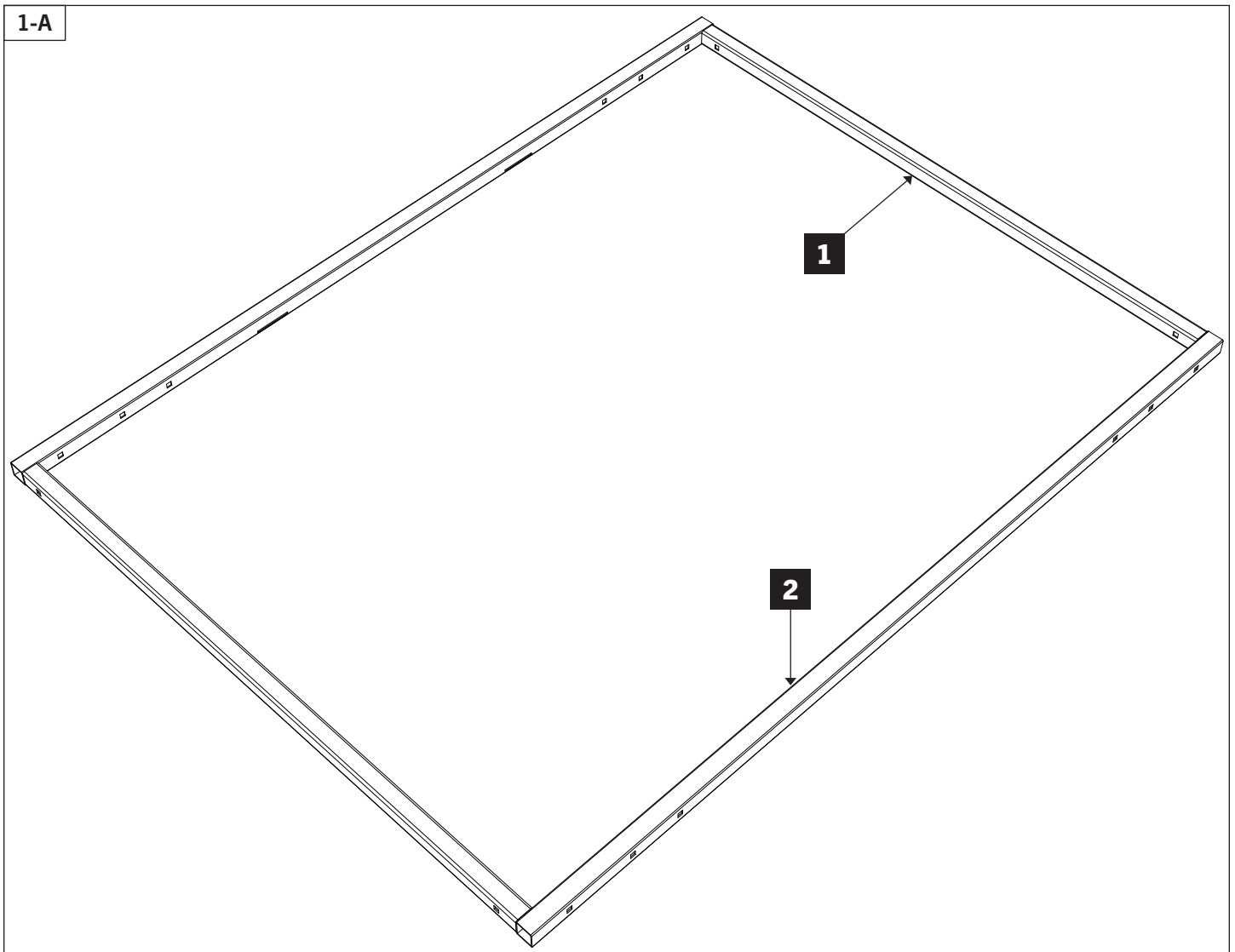

STEP 2 (OPTIONAL)

Tools Required:

- None
- **2-A** If optional Floor Plates **10** were purchased, slide them into the slots on both 100" Long Frame Tubes **2** as shown.
- **2-B** Once slotted, lay 72" Short Frame Tubes **1** into position as shown.

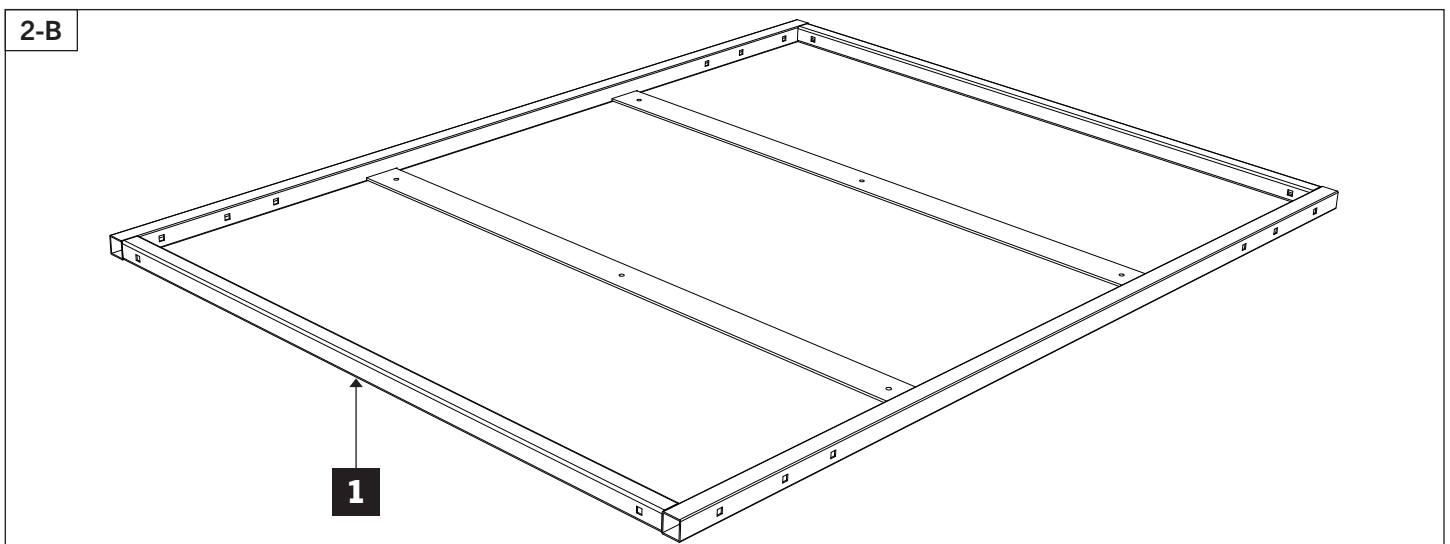
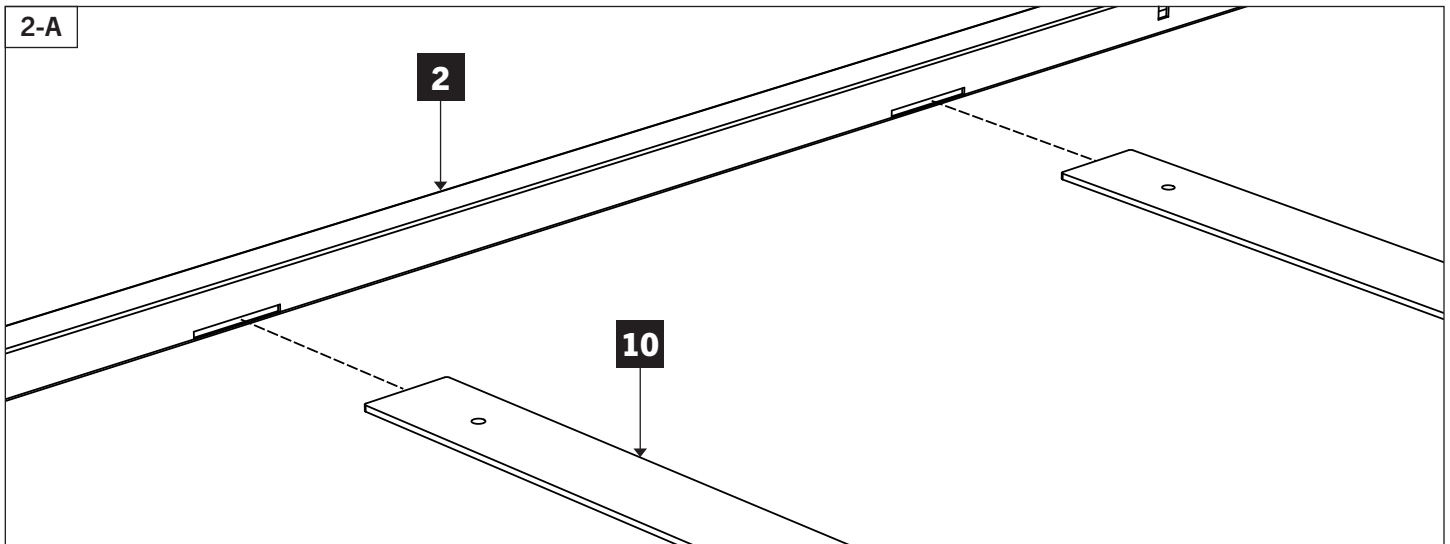

STEP 3

Tools Required:

- 3/4" Socket / Wrench

• Place Corner Brackets **3** on each corner of frame tubes and secure using 1/2" x 3" Carriage Bolts **4**, 1/2" Lock Washers **5**, and 1/2" Hex Nuts **6**.

• Fully tighten hardware once Corner Brackets are assembled.

Note:

- If Band Pegs were not purchased, assembly is complete.

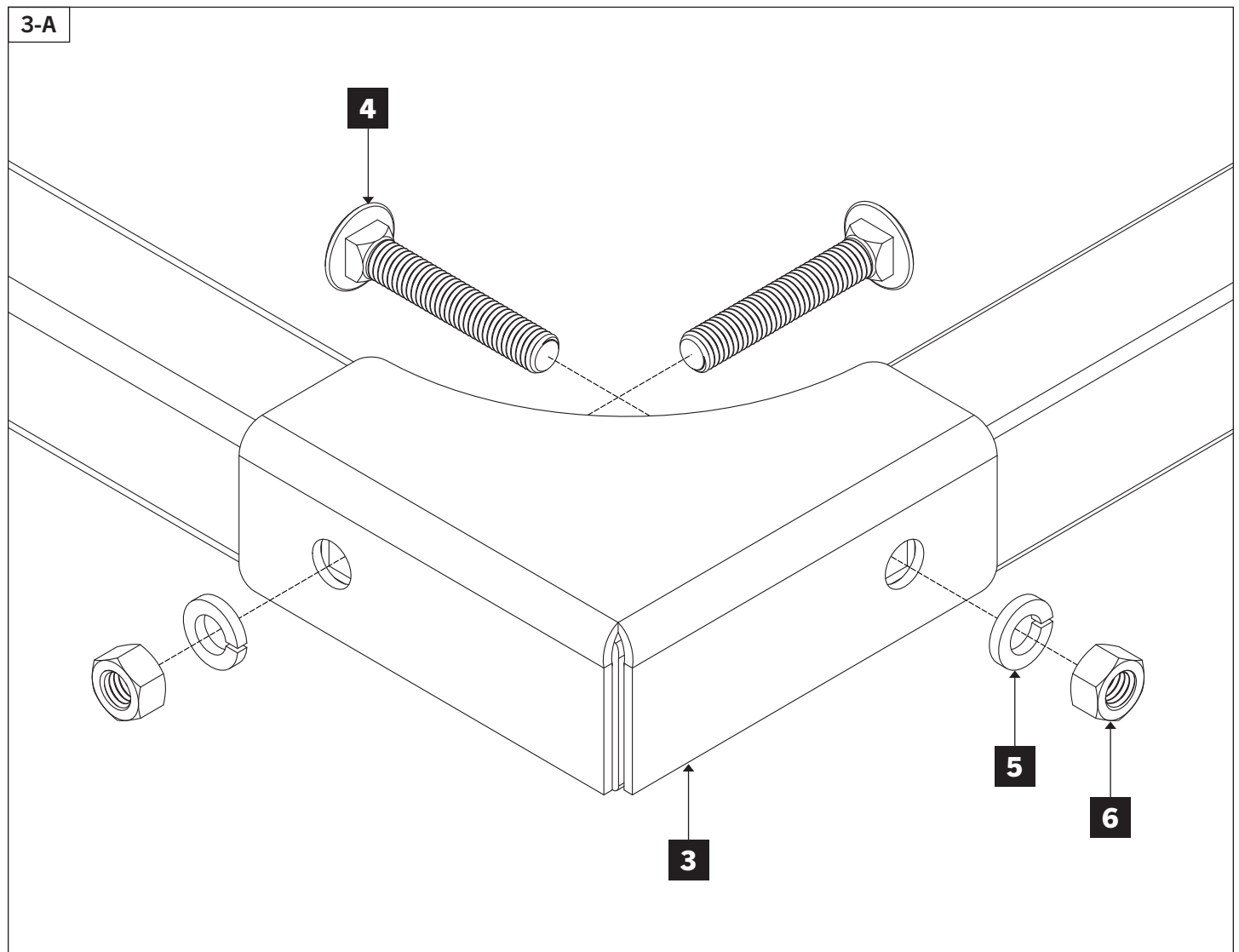
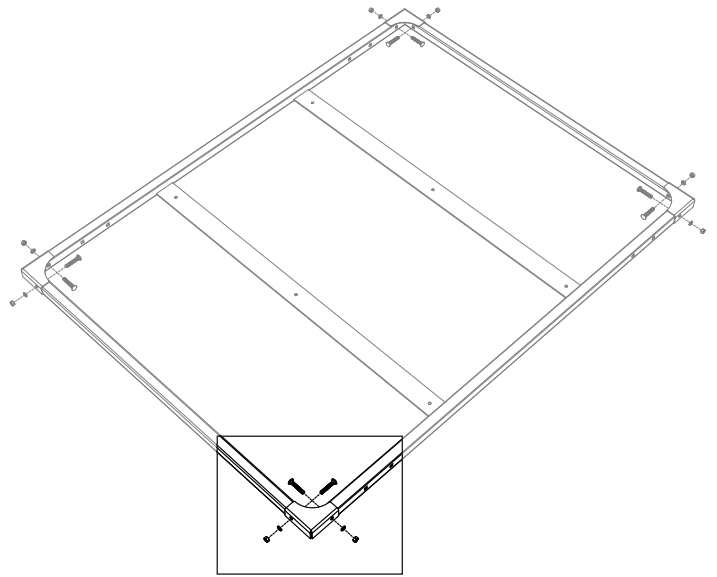

STEP 4 (OPTIONAL)

Tools Required:

- 3/4" Socket / Wrench

Note:

- If Band Pegs were not purchased, skip **STEP 4** and **STEP 5**.
- Attach Band Pegs **7** to the front and rear of the platform using 1/2" x 3" Carriage Bolts **4**, 1/2" Lock Washers **5**, and 1/2" Hex Nuts **6**.
- Fully tighten hardware once all Band Pegs are assembled.

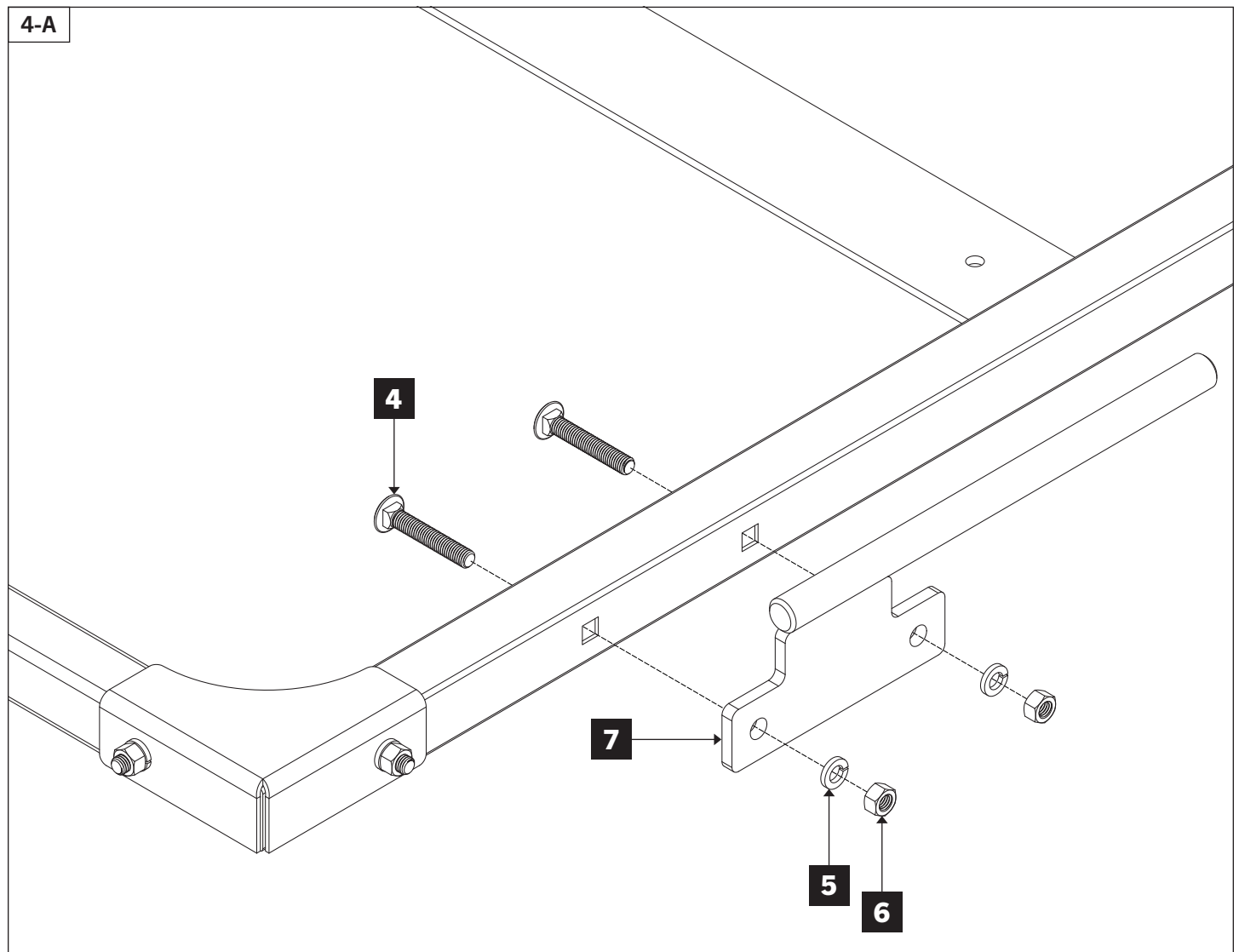
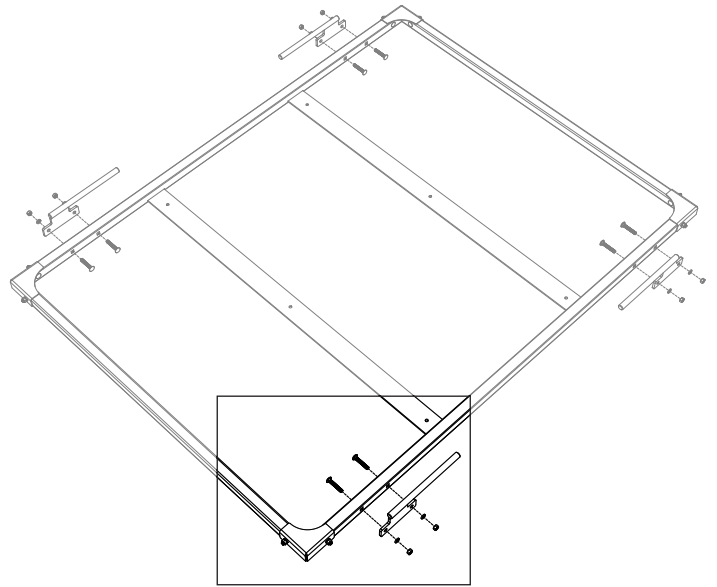

STEP 5 (OPTIONAL)

Tools Required:

- 3/8" Masonry Bit, 9/16" Socket / Wrench
- Ensure Oly Platform is in its permanent location and place Bolt-Down Brackets **8** on each corner, between Corner Bracket **3** and Band Peg **7**.
- Mark Bolt-Down Bracket hole locations and drill 9/16" holes using a hammer drill.
- Secure Bolt-Down Brackets to floor using 3/8" HD Concrete Anchors **9**.

