

# ROGUE FITNESS

## MONSTER SWING ARM GHD

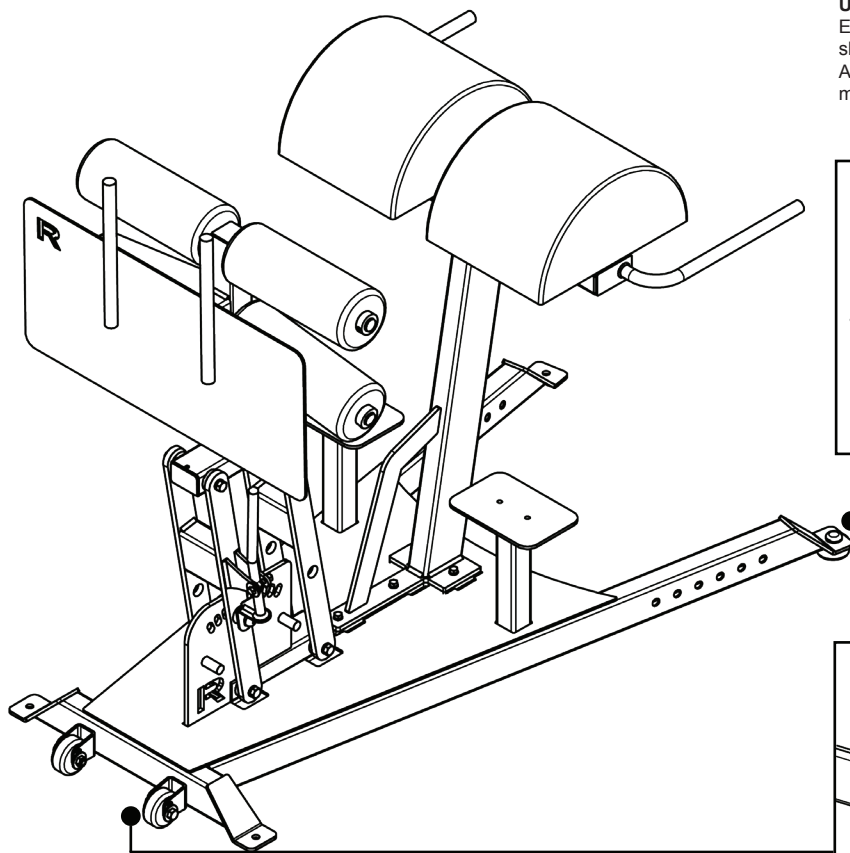

**ROGUE RECOMMENDS THIS UNIT BE ANCHORED FOR USE.** Hardware to bolt the rack to the floor is not included. Every application is unique and mounting hardware should be appropriately matched to the user's application. A 3/8 X 3.5 concrete wedge anchor (or similar) is recommended.

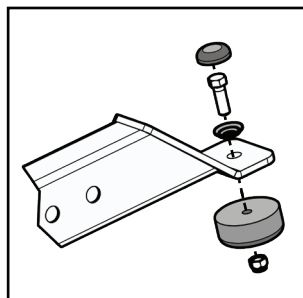

The provided rubber feet should be installed in the order shown if unit **IS NOT** mounted to the floor.

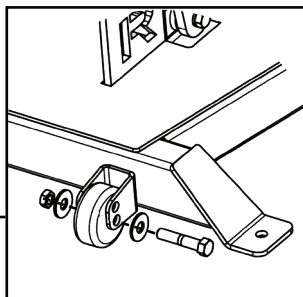

**Optional:** In place of Rubber Feet, the included Wheel Kit can be installed. Hardware: Hex Bolt, Flat Washer, Flat Washer, and secure with Lock Washer.

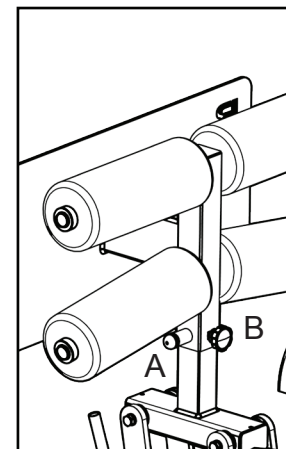

To Adjust Foot Height first set with (A) Pop Pin, secure by tightening (B) Knob. Always make sure the Adjustment is secure before use.

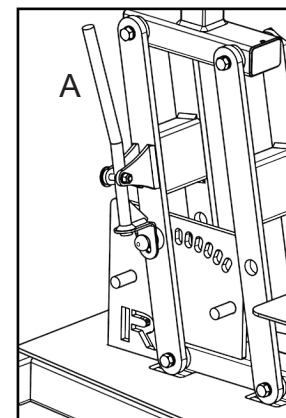

To adjust for different sized users, push handle (A) and move Seat Pads into desired position. Always make sure setting is fully secure before use.

## DISCLAIMER

Resistance training, gymnastics training, and activities at height are potentially dangerous and may lead to severe injury or even death. Use common sense when training, to obtain instruction in the proper execution of movements, and understand your limitations. This equipment must only be used by competent and responsible persons, or under the direct and visual control of a competent and responsible person. Obtaining instruction in appropriate techniques and methods of use is your own responsibility. You assume all risks and responsibilities for all damage, injury or death which may occur during or following incorrect use of this equipment in any matter whatsoever. Rogue Fitness bears no liability beyond the replacement value of the equipment in question.

## ⚠️ WARNING! ⚠️

MISUSE OF THIS CAN RESULT IN SEVERE INJURY

BOTH ROGUE FITNESS AND BUYER DISCLAIM ANY EXPRESS OR IMPLIED WARRANTY, INCLUDING, WITHOUT LIMITATION, WARRANTIES OR MERCHANTABILITY AND/OR FITNESS FOR A PARTICULAR PURPOSE WITH RESPECT TO THE EQUIPMENT. BUYER ASSUMES ALL LIABILITY IN USE OF EQUIPMENT.



**Rogue Fitness**  
 1080 Steelwood Rd.  
 Columbus Ohio 43212  
 614-358-6190  
 TEAM@Roguefitness.com