

ROGUE®

HORIZONTAL SINGLE BAR HOLDER

STEPS:

- Attach Single Bar Holder to outside of Rack/Rig using included 5/8" Hex Bolt, 5/8" Flat Washer, 5/8" Lock Washer, and 5/8" Hex Nut as shown.
- Check hardware before each use.

NOTE:

- 5/8" x 4-1/2" Hex Bolt used with Monster Lite 3X3 Tube. 5/8" x 3-1/2" Hex Bolt used with Infinity 2X3 Tube.
- Single Bar Holder should NEVER be mounted on the inside of Rack/Rig or anywhere near/underneath Pullup Bars.

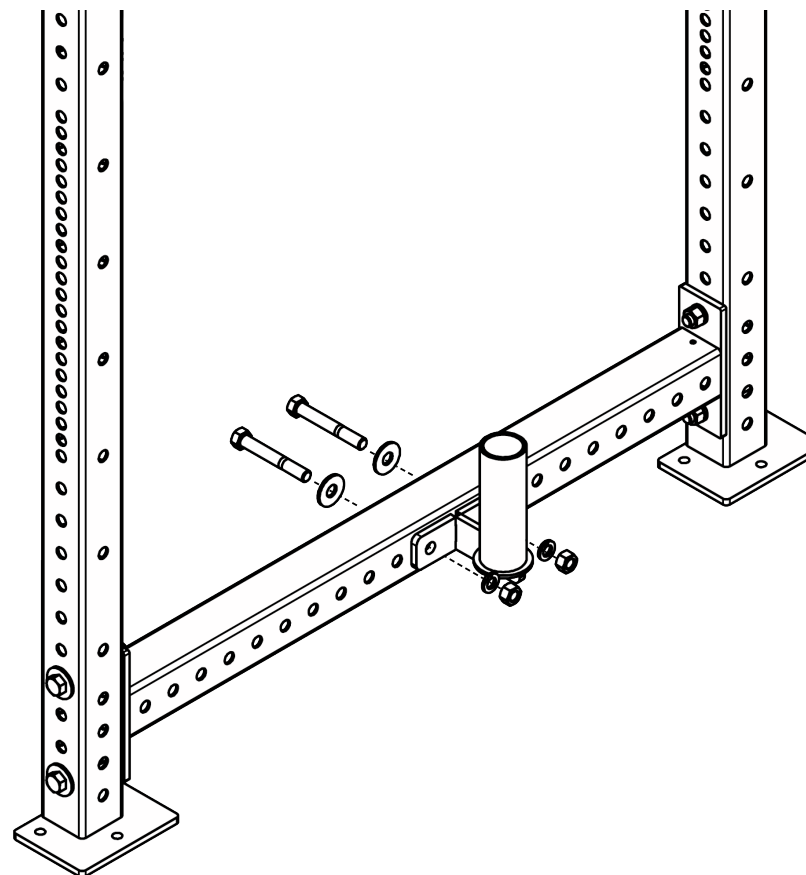

HARDWARE SIZE	TOOL REQUIRED
5/8" Hex Head	15/16" Socket / Wrench

IMPORTANT SAFETY INFORMATION

DISCLAIMER:

Resistance training, gymnastics training, and activities at height are potentially dangerous and may lead to severe injury or death. Use common sense when training, obtain instruction in the proper execution of movements, and understand your limitations. This equipment must only be used by competent and responsible persons. Obtaining instruction in appropriate techniques and methods of use is your own responsibility. You assume all risks and responsibilities for all damage, injury or death which may occur during or following incorrect use of this equipment in any matter whatsoever. Rogue Fitness bears no liability beyond the replacement value of the equipment in question.

WARNING:

MISUSE OF THIS CAN RESULT IN SEVERE INJURY.

Both Rogue Fitness and buyer disclaim any express or implied warranty, including, without limitation, warranties or merchantability and/or fitness for a particular purpose with respect to the equipment. Buyer assumes all liability to use of equipment.