

# ROGUE®

# RING HANGER 2.0

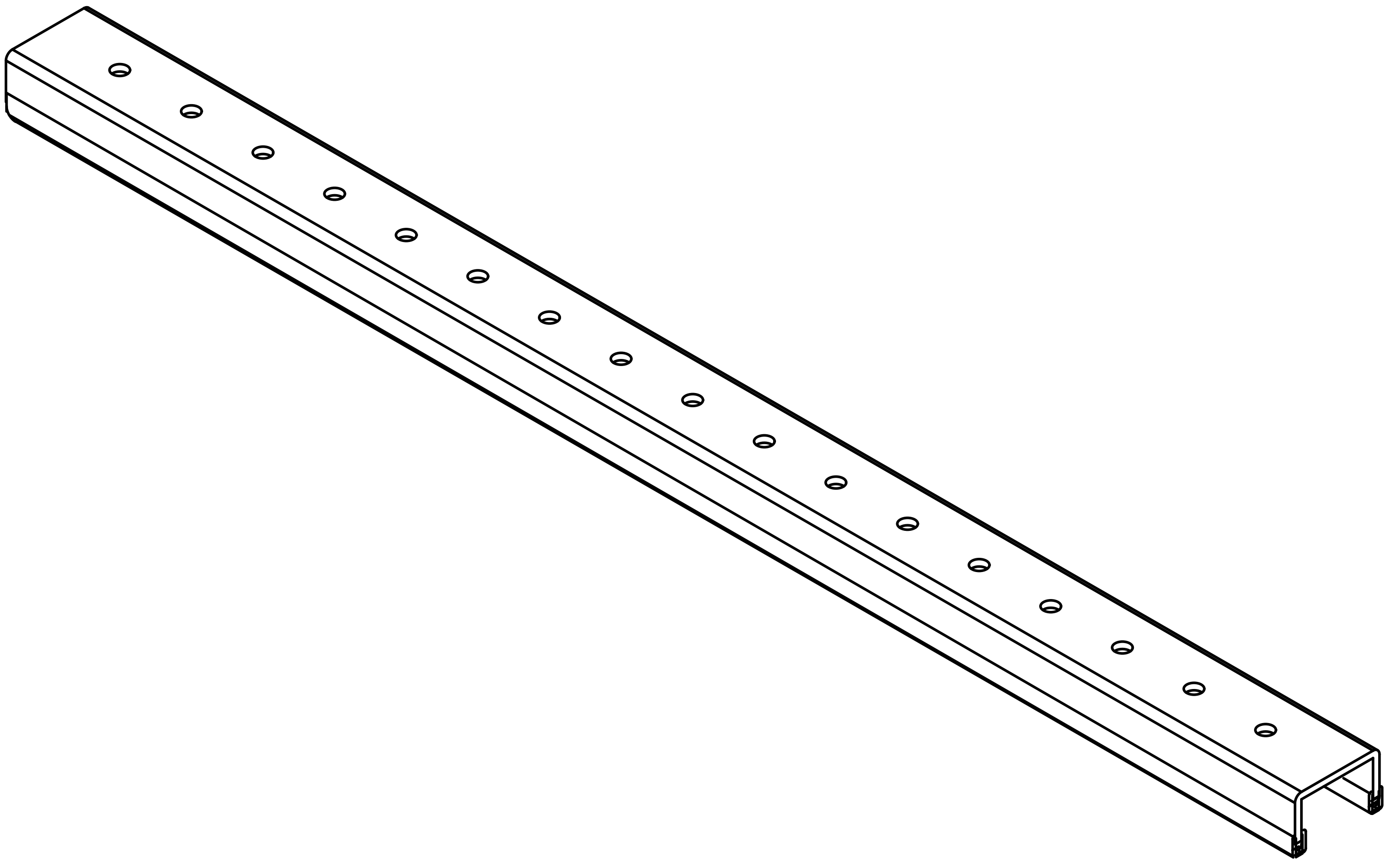

## **IMPORTANT SAFETY INFORMATION**

---

### **DISCLAIMER:**

Resistance training, gymnastics training, and activities at height are potentially dangerous and may lead to severe injury or even death. Use common sense when training, obtain instruction in the proper execution of movements, and understand your limitations. This equipment must only be used by competent and responsible persons. Obtaining instruction in appropriate techniques and methods of use is your own responsibility. You assume all risks and responsibilities for all damage, injury or death which may occur during or following incorrect use of this equipment in any matter whatsoever. Rogue Fitness bears no liability beyond the replacement value of the equipment in question.

### **WARNING:**

**MISUSE OF THIS PRODUCT CAN RESULT IN SEVERE INJURY.** Both Rogue Fitness and buyer disclaim any express or implied warranty, including, without limitation, warranties or merchantability and/or fitness for a particular purpose with respect to the equipment. Buyer assumes all liability to use of equipment.

# INCLUDED PARTS

Note: Images not shown at scale

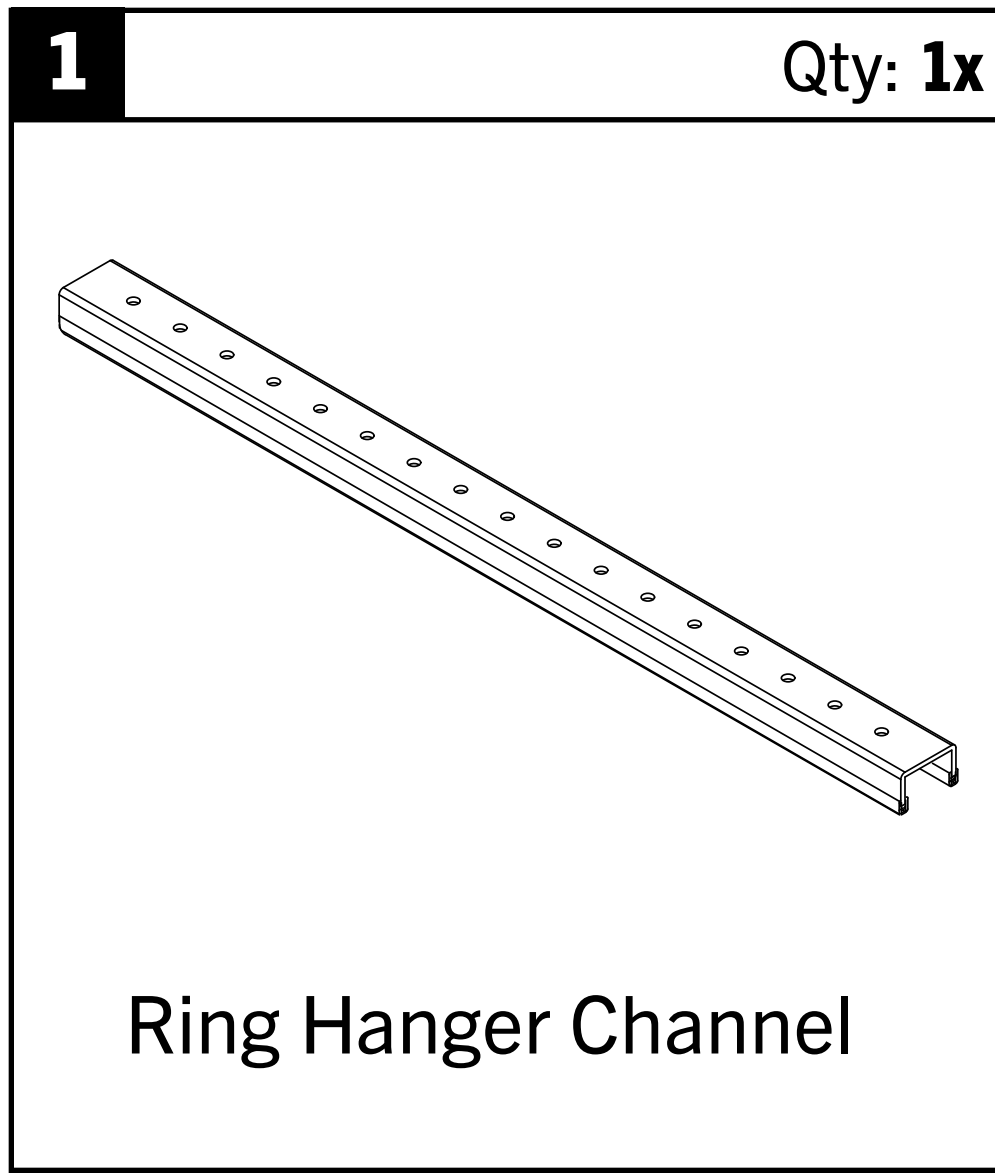

## STEP 1

• MOUNTING HARDWARE IS NOT INCLUDED. ROGUE IS NOT RESPONSIBLE FOR INSTALLATION.

• Every application is unique and mounting hardware should be appropriately matched to the users application.

SUGGESTIONS FOR MOUNTING TO:

- WOOD STUDS: 3/8" x 4.5" Lag Screw
- SOLID CONCRETE (not block): 3/8" x 4.5" Concrete Wedge Anchor

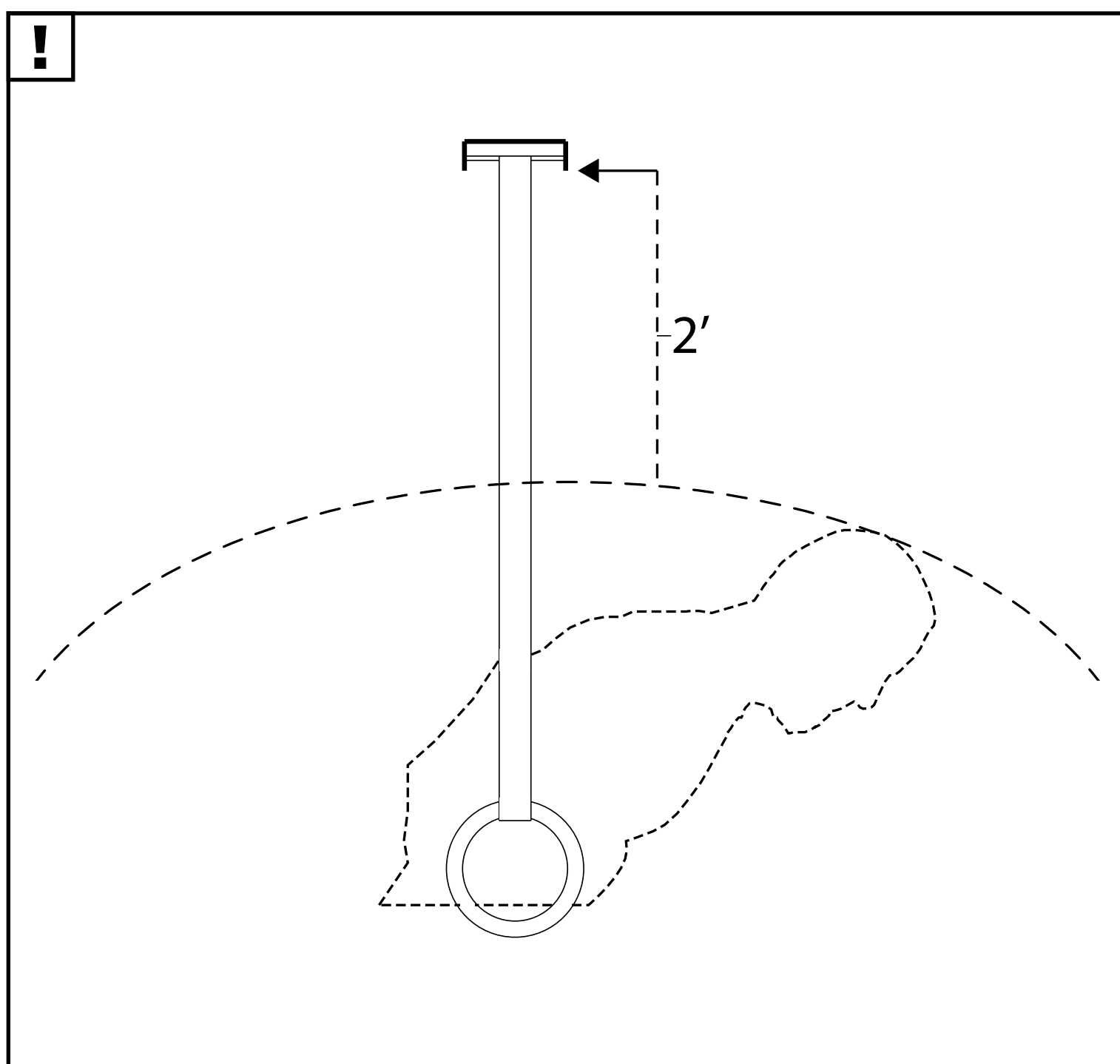
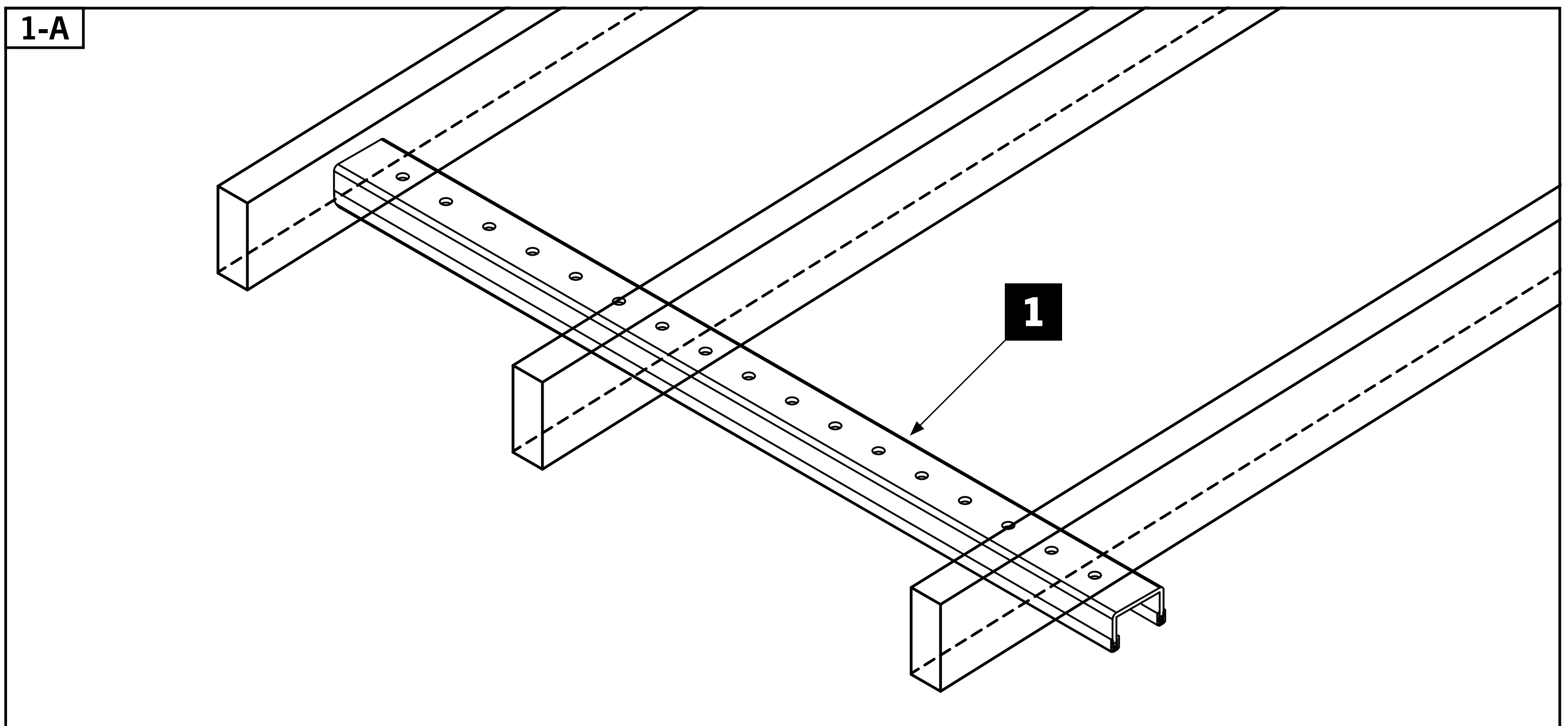

**⚠ WARNING! ⚠**  
MISUSE OF THIS EQUIPMENT CAN  
RESULT IN SEVERE INJURY



**ROGUE**



**SCAN FOR  
INSTRUCTIONS**



**IRON GAME  
PROGRAMMING**