

ROGUE FITNESS

RA0786-BZ CHALK STAND CASTER KIT

INSTALL (4) CASTERS AND (8) BRACKETS
ON CHALK STAND BASE LEGS

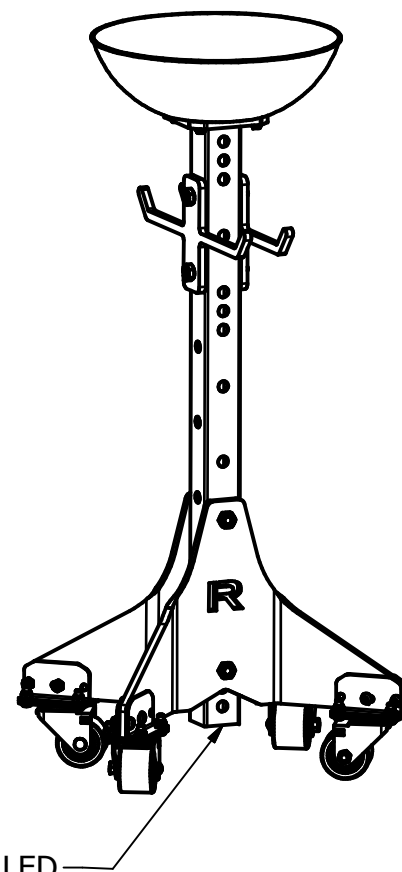
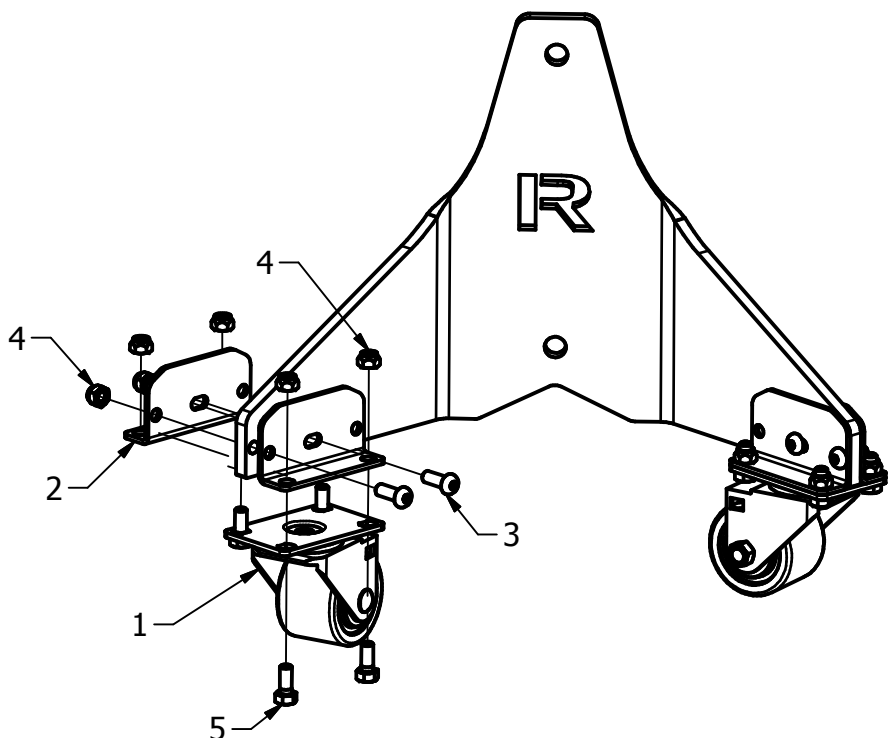

NOTE: WHEN CASTERS ARE INSTALLED
CHALK STAND HEIGHT CAN BE ADJUSTED
BY UTILIZING OTHER HOLES ON POST.

DISCLAIMER

Resistance training, gymnastics training, and activities at height are potentially dangerous and may lead to severe injury or even death. Use common sense when training, to obtain instruction in the proper execution of movements, and understand your limitations. This equipment must only be used by competent and responsible persons, or under the direct and visual control of a competent and responsible person. Obtaining instruction in appropriate techniques and methods of use is your own responsibility. You assume all risks and responsibilities for all damage, injury or death which may occur during or following incorrect use of this equipment in any matter whatsoever. Rogue Fitness bears no liability beyond the replacement value of the equipment in question.

* SEE SHEET 2 FOR ITEM DESCRIPTIONS AND QUANTITIES *



MISUSE OF THIS CAN RESULT IN
SEVERE INJURY

BOTH ROGUE FITNESS AND BUYER DISCLAIM ANY EXPRESS OR IMPLIED WARRANTY, INCLUDING, WITHOUT LIMITATION, WARRANTIES OR MERCHANTABILITY AND/OR FITNESS FOR A PARTICULAR PURPOSE WITH RESPECT TO THE EQUIPMENT. BUYER ASSUMES ALL LIABILITY IN USE OF EQUIPMENT.



Rogue Fitness
1080 Steelwood Rd.
Columbus, Ohio 43212
614-358-6190
TEAM@Roguefitness.com

ROGUE FITNESS

RA0786-BZ CHALK STAND CASTER KIT

INCLUDED PARTS
 *NOTE: IMAGES NOT SHOWN TO SCALE

ITEM	QTY.	DESCRIPTION
1	4	CASTER
2	8	CASTER BRACKET
3	8	5/16-18 X 7/8 BUTTON SOCKET CAP SCREW
4	24	5/16-18 LOCK NUT
5	16	5/16-18 X 3/4 HEX CAP SCREW

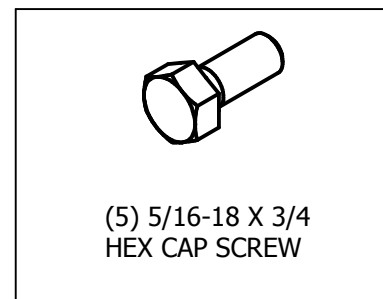
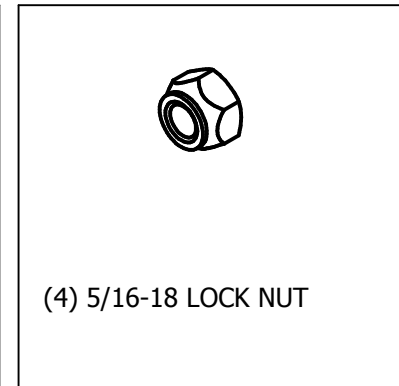
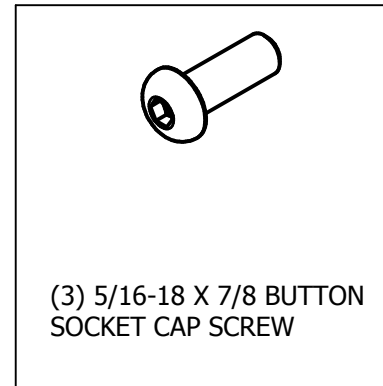
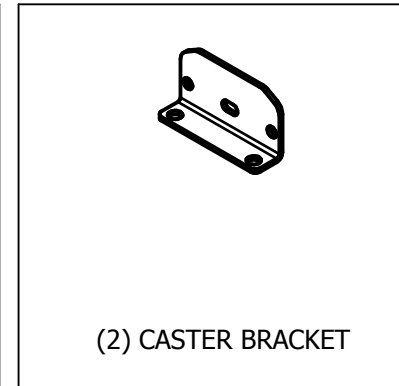
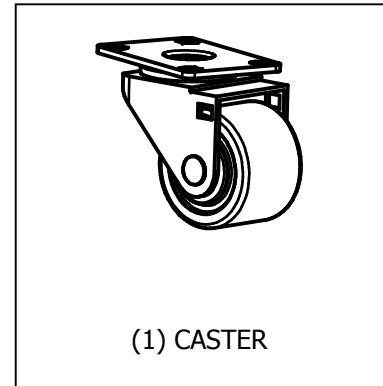

DISCLAIMER

Resistance training, gymnastics training, and activities at height are potentially dangerous and may lead to severe injury or even death. Use common sense when training, to obtain instruction in the proper execution of movements, and understand your limitations. This equipment must only be used by competent and responsible persons, or under the direct and visual control of a competent and responsible person. Obtaining instruction in appropriate techniques and methods of use is your own responsibility. You assume all risks and responsibilities for all damage, injury or death which may occur during or following incorrect use of this equipment in any matter whatsoever. Rogue Fitness bears no liability beyond the replacement value of the equipment in question.



WARNING!



MISUSE OF THIS CAN RESULT IN SEVERE INJURY

BOTH ROGUE FITNESS AND BUYER DISCLAIM ANY EXPRESS OR IMPLIED WARRANTY, INCLUDING, WITHOUT LIMITATION, WARRANTIES OR MERCHANTABILITY AND/OR FITNESS FOR A PARTICULAR PURPOSE WITH RESPECT TO THE EQUIPMENT. BUYER ASSUMES ALL LIABILITY IN USE OF EQUIPMENT.



Rogue Fitness
 1080 Steelwood Rd.
 Columbus, Ohio 43212
 614-358-6190
 TEAM@Roguefitness.com