

## BASIC MONSTER RIG NAMEPLATE

### DISCLAIMER

Resistance training, gymnastics training, and activities at height are potentially dangerous and may lead to severe injury or even death. Use common sense when training, to obtain instruction in the proper execution of movements, and understand your limitations. This equipment must only be used by competent and responsible persons, or under the direct and visual control of a competent and responsible person. Obtaining instruction in appropriate techniques and methods of use is your own responsibility. You assume all risks and responsibilities for all damage, injury or death which may occur during or following incorrect use of this equipment in any matter whatsoever. Rogue Fitness bears no liability beyond the replacement value of the equipment in question.



**MISUSE OF THIS CAN RESULT IN SEVERE INJURY**

BOTH ROGUE FITNESS AND BUYER DISCLAIM ANY EXPRESS OR IMPLIED WARRANTY, INCLUDING, WITHOUT LIMITATION, WARRANTIES OR MERCHANTABILITY AND/OR FITNESS FOR A PARTICULAR PURPOSE WITH RESPECT TO THE EQUIPMENT. BUYER ASSUMES ALL LIABILITY IN USE OF EQUIPMENT.



**Rogue Fitness**  
1080 Steelwood Rd.  
Columbus, Ohio 43212  
614-358-6190  
TEAM@Roguefitness.com

# ROGUE FITNESS

## BASIC MONSTER RIG NAMEPLATE

INCLUDED PARTS  
 \*NOTE: IMAGES NOT SHOWN TO SCALE

PARTS LIST		
ITEM	QTY	DESCRIPTION
1	2	MONSTER 2.0 NAMEPLATE
2	2	MONSTER 2.0 NAMEPLATE SS BACKER

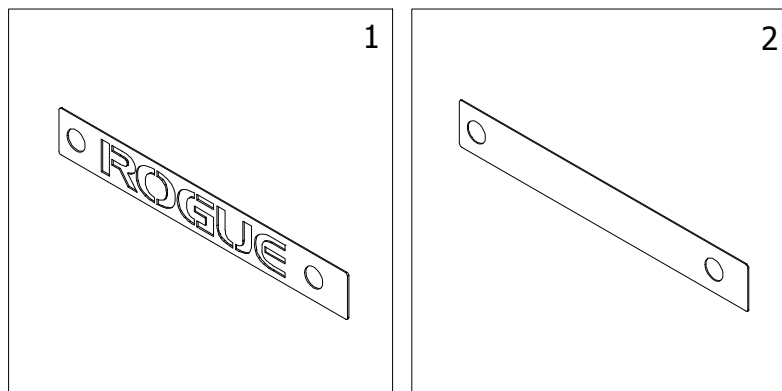

## DISCLAIMER

Resistance training, gymnastics training, and activities at height are potentially dangerous and may lead to severe injury or even death. Use common sense when training, to obtain instruction in the proper execution of movements, and understand your limitations. This equipment must only be used by competent and responsible persons, or under the direct and visual control of a competent and responsible person. Obtaining instruction in appropriate techniques and methods of use is your own responsibility. You assume all risks and responsibilities for all damage, injury or death which may occur during or following incorrect use of this equipment in any matter whatsoever. Rogue Fitness bears no liability beyond the replacement value of the equipment in question.



**WARNING!**

MISUSE OF THIS CAN RESULT IN SEVERE INJURY

BOTH ROGUE FITNESS AND BUYER DISCLAIM ANY EXPRESS OR IMPLIED WARRANTY, INCLUDING, WITHOUT LIMITATION, WARRANTIES OR MERCHANTABILITY AND/OR FITNESS FOR A PARTICULAR PURPOSE WITH RESPECT TO THE EQUIPMENT. BUYER ASSUMES ALL LIABILITY IN USE OF EQUIPMENT.



**Rogue Fitness**  
 1080 Steelwood Rd.  
 Columbus, Ohio 43212  
 614-358-6190  
 TEAM@Roguefitness.com

# ROGUE FITNESS

## BASIC MONSTER RIG NAMEPLATE

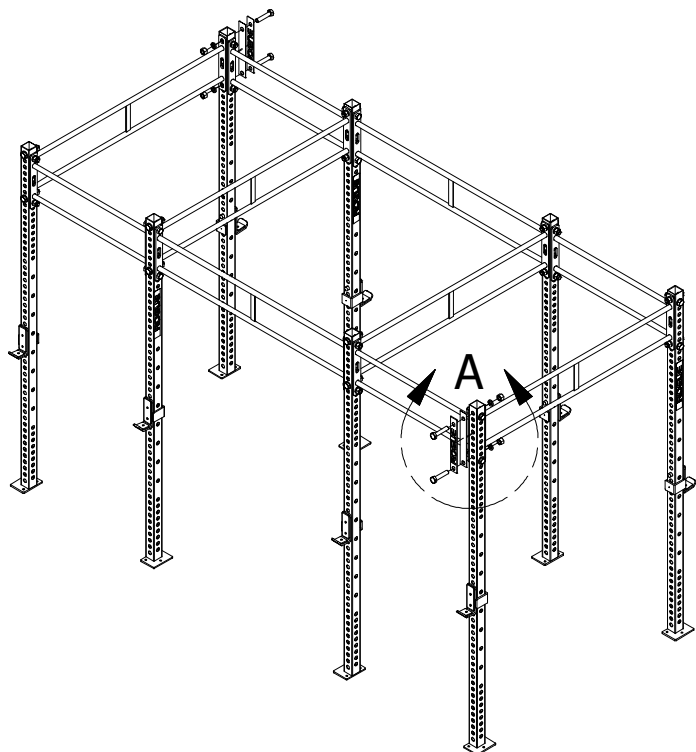

\*M-14 SHOWN AS EXAMPLE ONLY,  
NAMEPLATE IS COMPATIBLE WITH  
ALL BASIC MONSTER RIGS

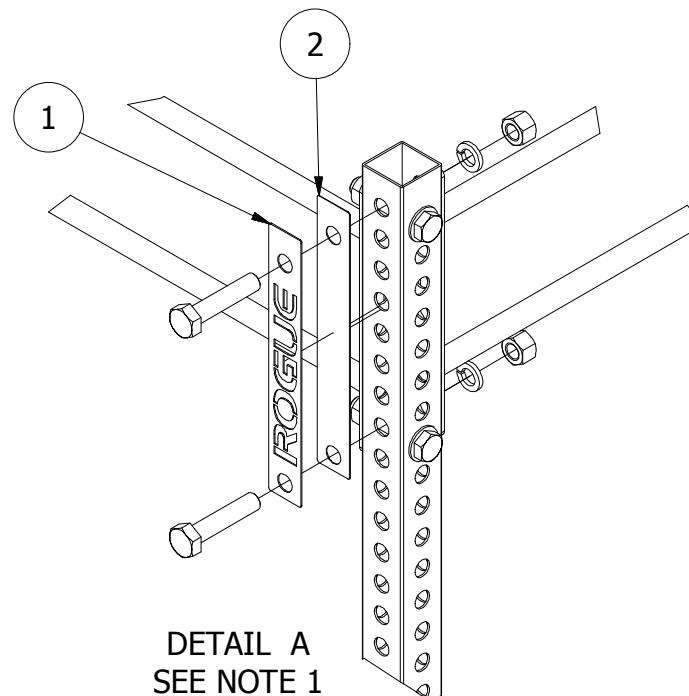

**STEP 1:**  
ATTACH NAMEPLATE AND STAINLESS BACKER TO THE TOP RIGHT SIDE OF RIG  
ON BOTH SIDES AS SHOWN.

\*SECURE USING HARDWARE FROM RIG KIT; 1"x4.75" HEX BOLTS,  
1" LOCK WASHERS AND 1" HEX NUT.

**NOTE 1:**  
FLAT WASHERS WILL NOT BE USED, NAMEPLATE ACTS AS FLAT WASHER.

## DISCLAIMER

Resistance training, gymnastics training, and activities at height are potentially dangerous and may lead to severe injury or even death. Use common sense when training, to obtain instruction in the proper execution of movements, and understand your limitations. This equipment must only be used by competent and responsible persons, or under the direct and visual control of a competent and responsible person. Obtaining instruction in appropriate techniques and methods of use is your own responsibility. You assume all risks and responsibilities for all damage, injury or death which may occur during or following incorrect use of this equipment in any matter whatsoever. Rogue Fitness bears no liability beyond the replacement value of the equipment in question.



# WARNING!



MISUSE OF THIS CAN RESULT IN  
SEVERE INJURY

BOTH ROGUE FITNESS AND BUYER DISCLAIM ANY EXPRESS  
OR IMPLIED WARRANTY, INCLUDING, WITHOUT LIMITATION,  
WARRANTIES OR MERCHANTABILITY AND/OR FITNESS FOR A  
PARTICULAR PURPOSE WITH RESPECT TO THE EQUIPMENT.  
BUYER ASSUMES ALL LIABILITY IN USE OF EQUIPMENT.



**Rogue Fitness**  
1080 Steelwood Rd.  
Columbus, Ohio 43212  
614-358-6190  
TEAM@Roguefitness.com