

ROGUE®

THE 3X3 STRIP 2.0

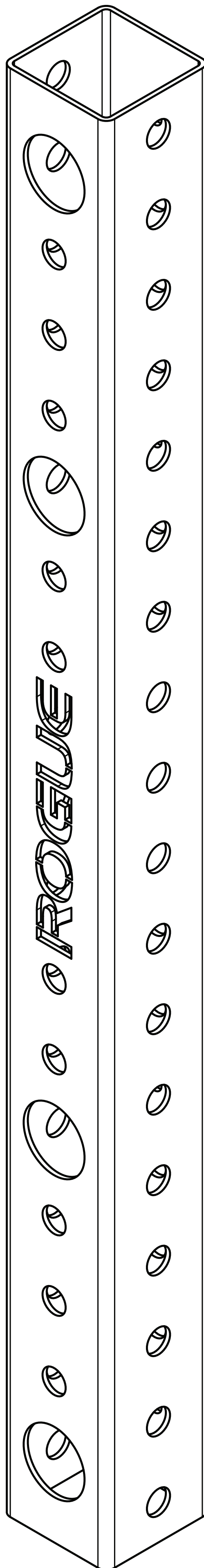

⚠ IMPORTANT SAFETY INFORMATION

DISCLAIMER:

Resistance training, gymnastics training, and activities at height are potentially dangerous and may lead to severe injury or even death. Use common sense when training, obtain instruction in the proper execution of movements, and understand your limitations. This equipment must only be used by competent and responsible persons. Obtaining instruction in appropriate techniques and methods of use is your own responsibility. You assume all risks and responsibilities for all damage, injury or death which may occur during or following incorrect use of this equipment in any matter whatsoever. Rogue Fitness bears no liability beyond the replacement value of the equipment in question.

WARNING:

MISUSE OF THIS PRODUCT CAN RESULT IN SEVERE INJURY. Both Rogue Fitness and buyer disclaim any express or implied warranty, including, without limitation, warranties or merchantability and/or fitness for a particular purpose with respect to the equipment. Buyer assumes all liability to use of equipment.

INSTALLATION STEPS

- 3/8" x 2-1/2" Wood Lag Screws and 3/8" Flat Washers are recommended if mounting Strip to wall or wood stud.
- 15/64" Diameter drill bit recommended if using 3/8" Lag Screws.
- Identify stud in wall and mark desired height of top hole. Drill pilot hole in marked location.
- Put thread-side of screw through washer then screw through top hole at the back of the Strip into wall until wood but do not fully tighten.
- Let strip hang and ensure it is square using a level then mark locations of the remaining holes.
- Hold strip to the side as shown in **1-B** and drill pilot holes in the marked locations.
- Put thread side of screw through the washer then screw through bottom 3/8" hole in back of Strip into the wall loosely.
- Screw in the remaining two Lag Screws and fully tighten all screws.
- If attempting to secure Strip to concrete or other material, the buyer is responsible for using correct hardware.
- It is the buyer's responsibility to install strip in a location and with hardware capable of supporting the aggregate weight of strip, all gear mounted or stored, and any person using it.
- If you are not confident in your mechanical skills, please seek the help of a professional to perform the installation.

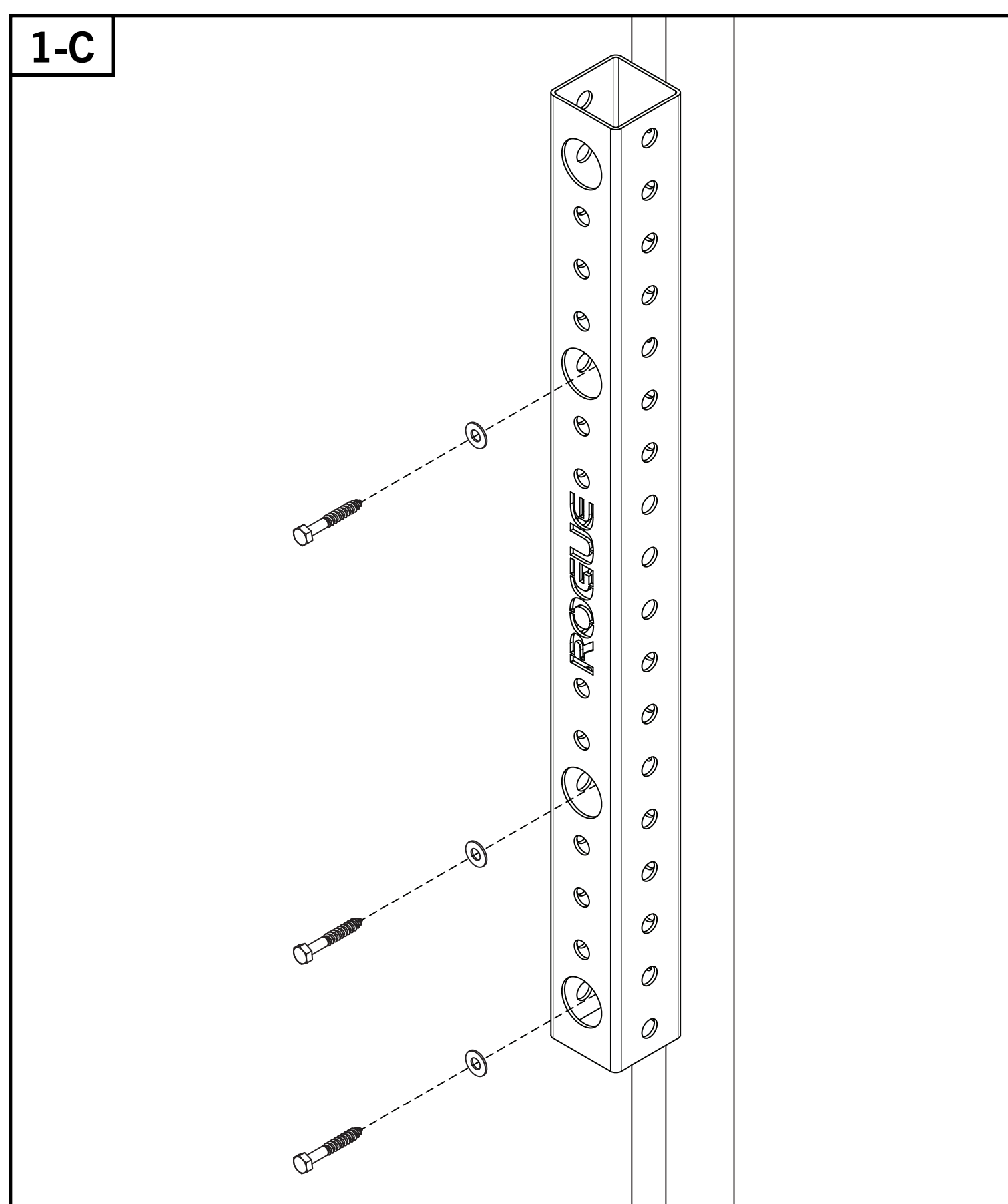
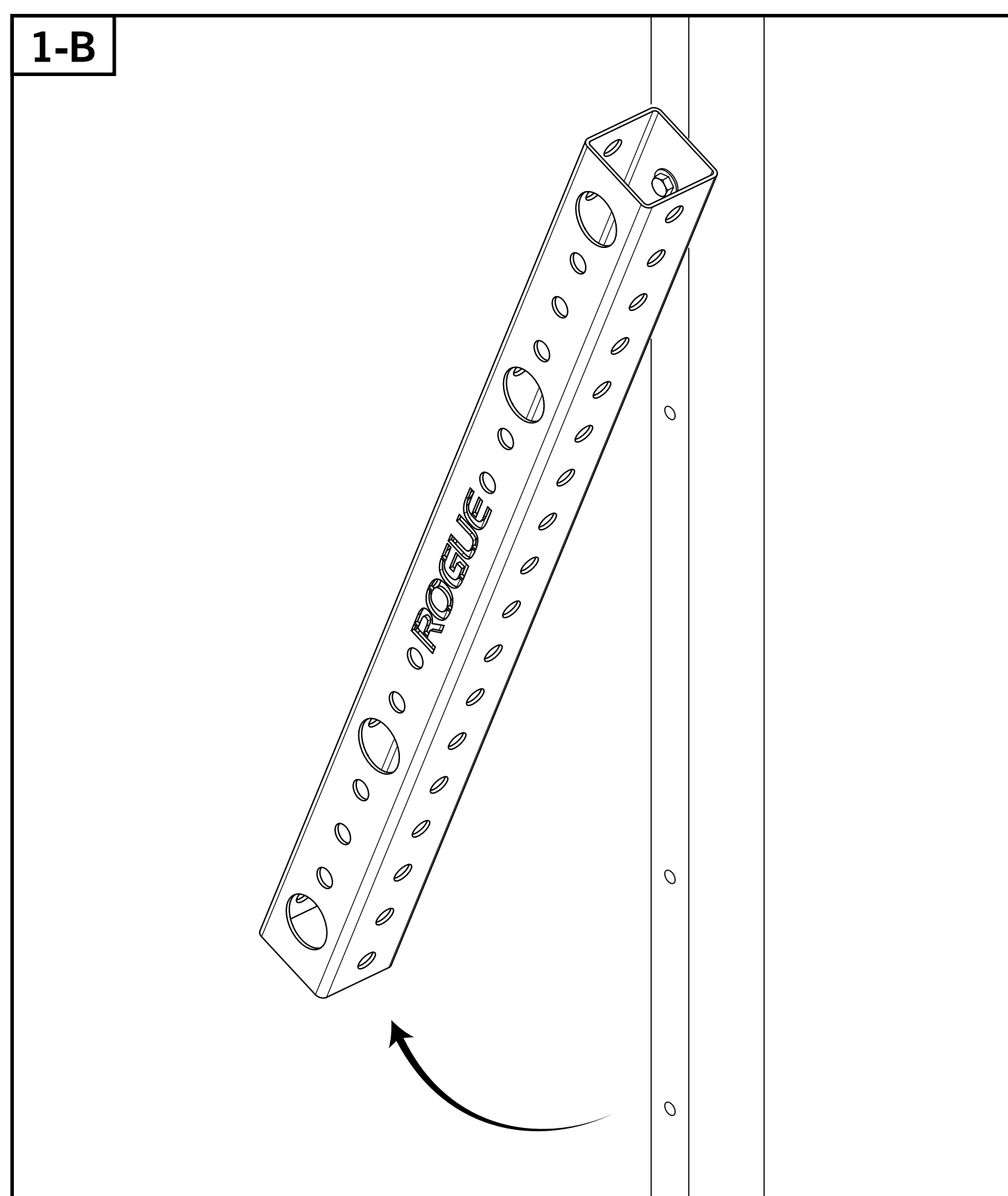
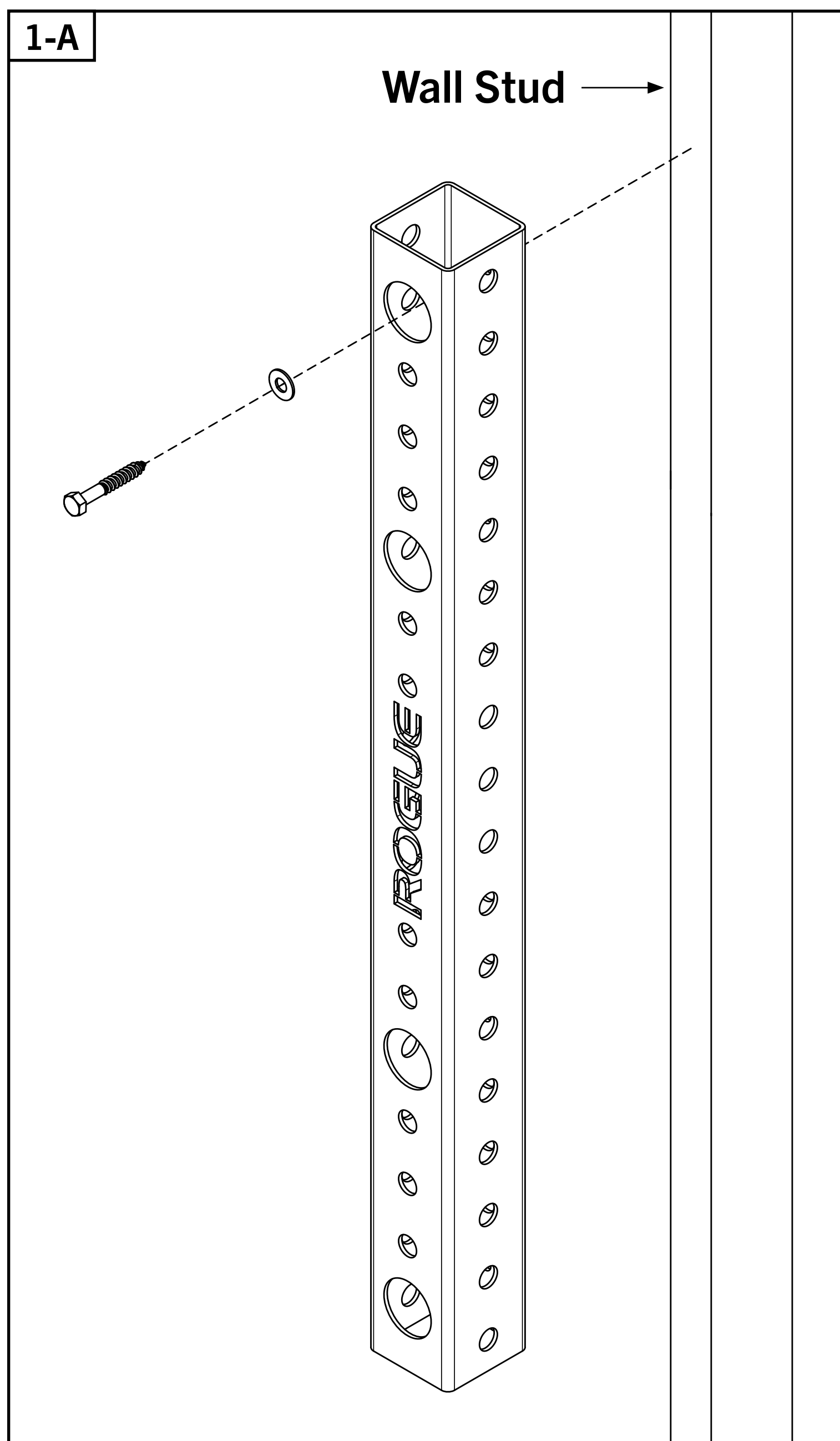
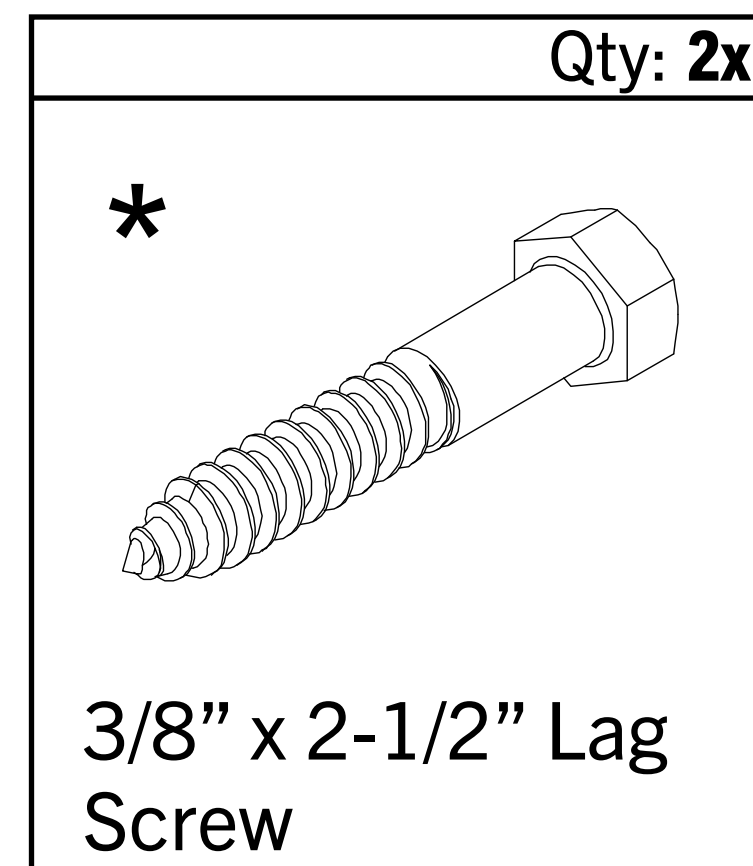
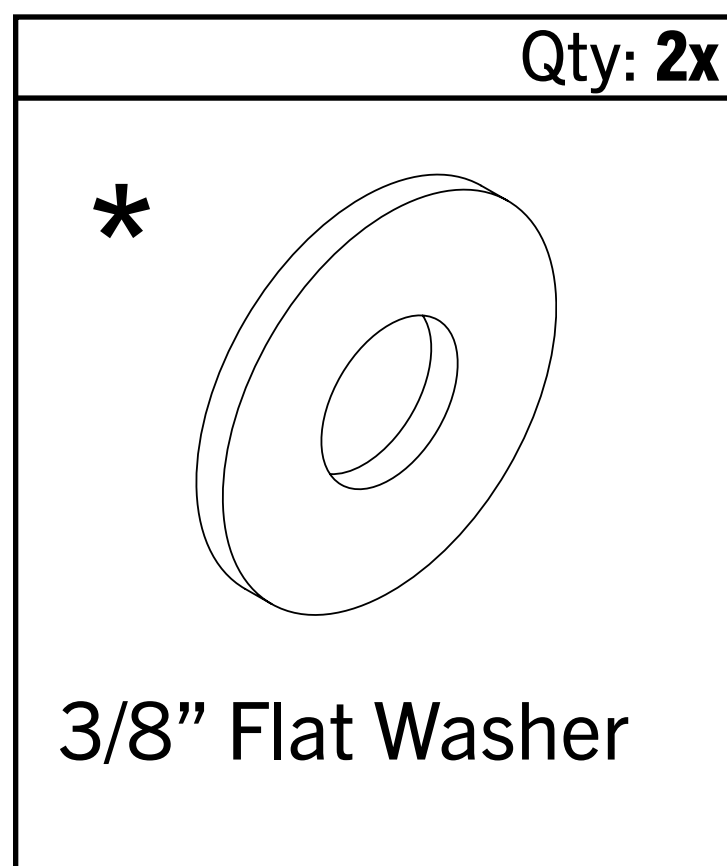

ROGUE



**SCAN FOR
INSTRUCTIONS**



**IRON GAME
PROGRAMMING**

IS0453-1