

MONSTER PLATE LOAD SLINGER

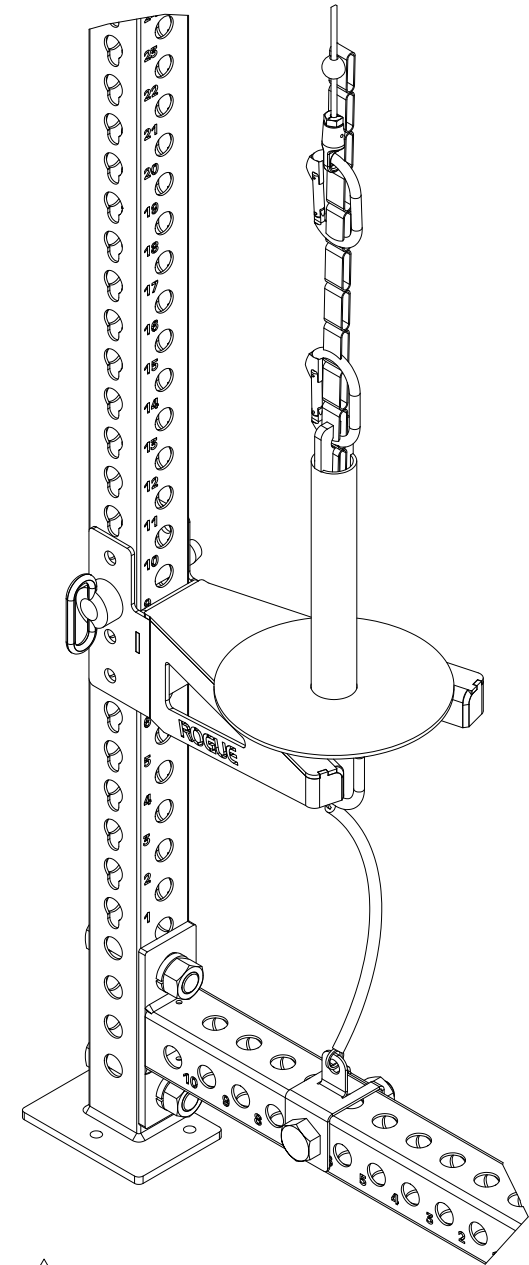

DISCLAIMER

Resistance training, gymnastics training, and activities at height are potentially dangerous and may lead to severe injury or even death. Use common sense when training, to obtain instruction in the proper execution of movements, and understand your limitations. This equipment must only be used by competent and responsible persons, or under the direct and visual control of a competent and responsible person. Obtaining instruction in appropriate techniques and methods of use is your own responsibility. You assume all risks and responsibilities for all damage, injury or death which may occur during or following incorrect use of this equipment in any matter whatsoever. Rogue Fitness bears no liability beyond the replacement value of the equipment in question.



WARNING!

MISUSE OF THIS CAN RESULT IN
SEVERE INJURY

BOTH ROGUE FITNESS AND BUYER DISCLAIM ANY EXPRESS OR IMPLIED WARRANTY, INCLUDING, WITHOUT LIMITATION, WARRANTIES OR MERCHANTABILITY AND/OR FITNESS FOR A PARTICULAR PURPOSE WITH RESPECT TO THE EQUIPMENT. BUYER ASSUMES ALL LIABILITY IN USE OF EQUIPMENT.



Rogue Fitness
545 E 5th Ave.
Columbus, Ohio 43201
614-358-6190
team@roguefitness.com

ROGUE

MONSTER PLATE LOAD SLINGER

INCLUDED PARTS

*NOTE: IMAGES NOT SHOWN TO SCALE

PARTS LIST		
ITEM	QTY	DESCRIPTION
1	1	MONSTER PLATE BASE
2	1	SLINGER PLATE POST
3	1	ECHO MONSTER SHACKLE
4	1	1" DETENT PIN
5	1	1" x 4.75" HEX BOLT
6	1	1" LOCK WASHER
7	1	1" HEX NUT
8	1*	CARABINER
9	1	STABILITY BAND

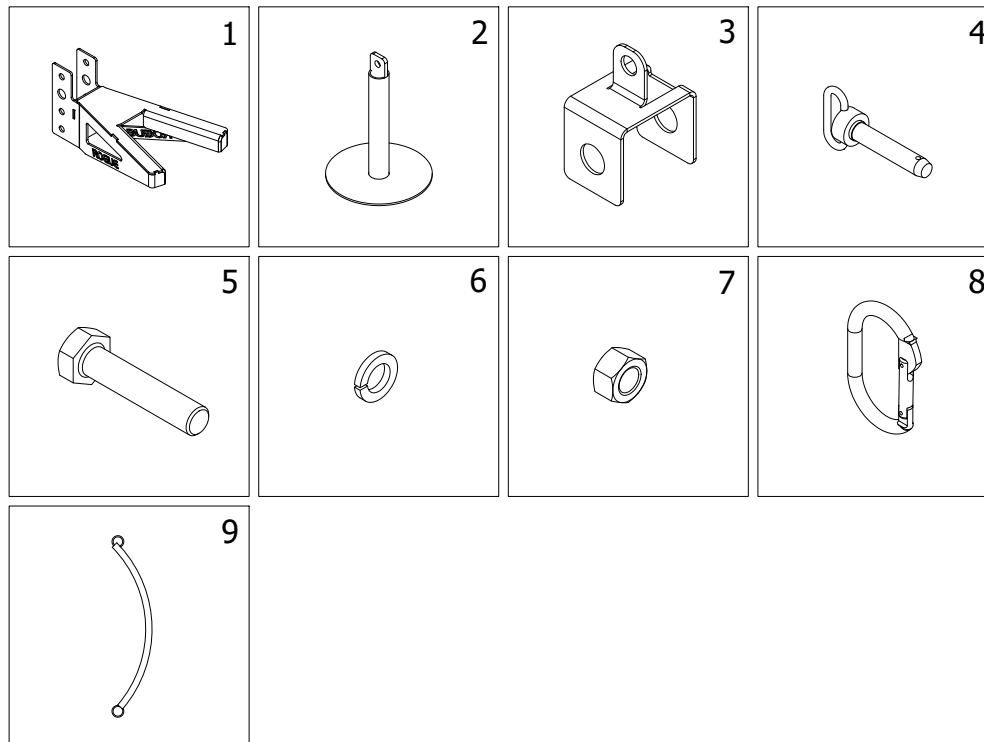

*ADDITIONAL CARABINERS INCLUDED WITH THE STANDARD SLINGER KIT WILL BE USED.

DISCLAIMER

Resistance training, gymnastics training, and activities at height are potentially dangerous and may lead to severe injury or even death. Use common sense when training, to obtain instruction in the proper execution of movements, and understand your limitations. This equipment must only be used by competent and responsible persons, or under the direct and visual control of a competent and responsible person. Obtaining instruction in appropriate techniques and methods of use is your own responsibility. You assume all risks and responsibilities for all damage, injury or death which may occur during or following incorrect use of this equipment in any matter whatsoever. Rogue Fitness bears no liability beyond the replacement value of the equipment in question.



WARNING!



MISUSE OF THIS CAN RESULT IN SEVERE INJURY

BOTH ROGUE FITNESS AND BUYER DISCLAIM ANY EXPRESS OR IMPLIED WARRANTY, INCLUDING, WITHOUT LIMITATION, WARRANTIES OR MERCHANTABILITY AND/OR FITNESS FOR A PARTICULAR PURPOSE WITH RESPECT TO THE EQUIPMENT. BUYER ASSUMES ALL LIABILITY IN USE OF EQUIPMENT.



Rogue Fitness
545 E 5th Ave.
Columbus, Ohio 43201
614-358-6190
team@roguefitness.com

ROGUE

MONSTER PLATE LOAD SLINGER

*****BEFORE STARTING THE PLATE LOAD INSTRUCTIONS COMPLETE THE STANDARD SLINGER INSTRUCTIONS INCLUDED WITH THE SLINGER KIT*****

STEP 1:

ATTACH THE ECHO SHACKLE IN THE 5TH HOLE FROM THE OUTSIDE UPRIGHT WITH THE 1" HARDWARE.

ATTACH THE PLATE LOAD BASE TO THE UPRIGHT IN THE 13TH HOLE FROM THE BOTTOM USING THE 1" DETENT PIN.

THE HEIGHT OF THE BASE CAN BE ADJUSTED UP TO CHANGE THE WEIGHT ENGAGEMENT.

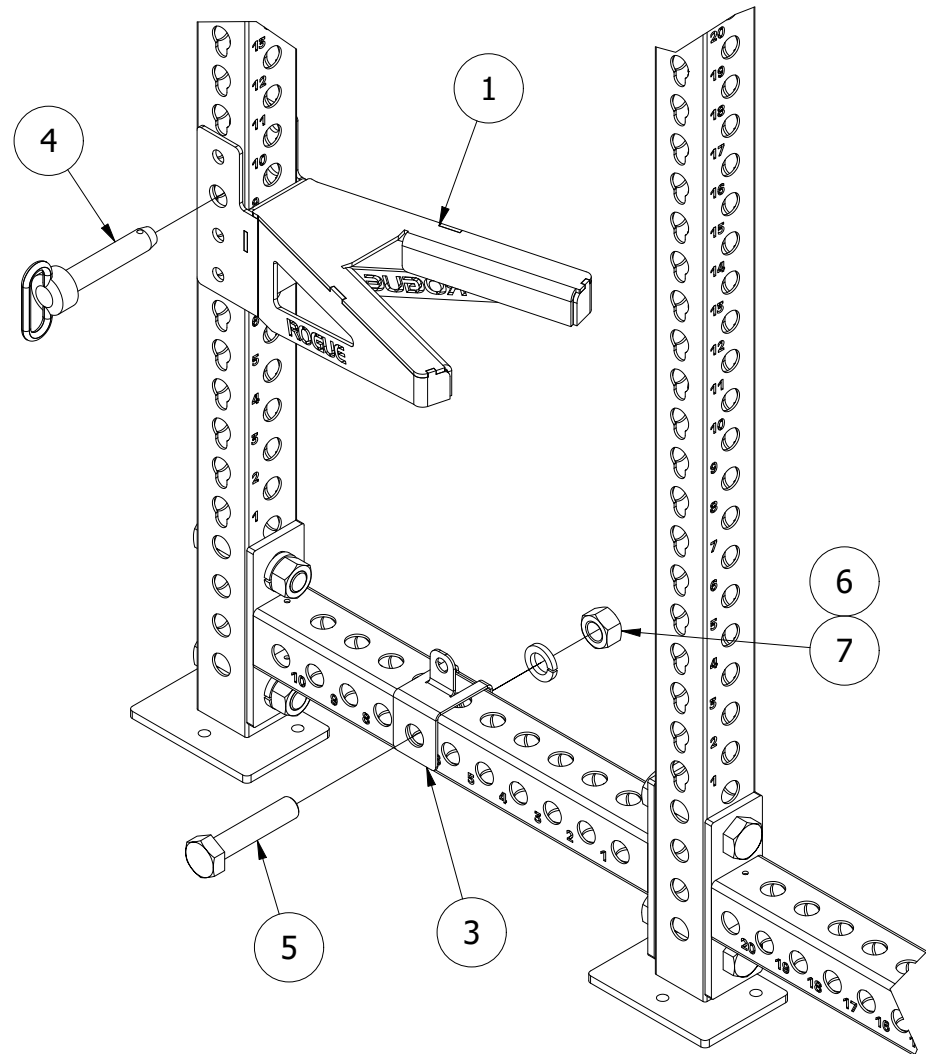

DISCLAIMER

Resistance training, gymnastics training, and activities at height are potentially dangerous and may lead to severe injury or even death. Use common sense when training, to obtain instruction in the proper execution of movements, and understand your limitations. This equipment must only be used by competent and responsible persons, or under the direct and visual control of a competent and responsible person. Obtaining instruction in appropriate techniques and methods of use is your own responsibility. You assume all risks and responsibilities for all damage, injury or death which may occur during or following incorrect use of this equipment in any matter whatsoever. Rogue Fitness bears no liability beyond the replacement value of the equipment in question.



WARNING!

MISUSE OF THIS CAN RESULT IN SEVERE INJURY

BOTH ROGUE FITNESS AND BUYER DISCLAIM ANY EXPRESS OR IMPLIED WARRANTY, INCLUDING, WITHOUT LIMITATION, WARRANTIES OR MERCHANTABILITY AND/OR FITNESS FOR A PARTICULAR PURPOSE WITH RESPECT TO THE EQUIPMENT. BUYER ASSUMES ALL LIABILITY IN USE OF EQUIPMENT.



Rogue Fitness
545 E 5th Ave.
Columbus, Ohio 43201
614-358-6190
team@roguefitness.com

ROGUE

MONSTER PLATE LOAD SLINGER

STEP 2:

PLACE THE SLINGER PLATE POST ON THE BASE.

ATTACH A CARABINER TO THE UNDERSIDE OF THE POST.

ATTACH THE STABILIZER BAND TO THE UNDERSIDE POST CARABINER, THEN TO THE ECHO SHACKLE.

IF USING A 90" RACK, ATTACH THE CABLE CARABINER DIRECTLY TO THE PLATE POST.

IF USING A 100" OR 108" RACK, ATTACH A CARABINER INTO THE PLATE POST, THEN LOOP THE END OF THE EXTENSION STRAP INTO IT.

LOOP THE EXTENSION STRAP THROUGH THE CABLE SIDE CARABINER SO THAT THERE IS MINIMAL SLACK, ATTACHMENT LOCATION WILL DEPEND ON THE RACK HEIGHT. (ACTUAL LOCATION NOT SHOWN)

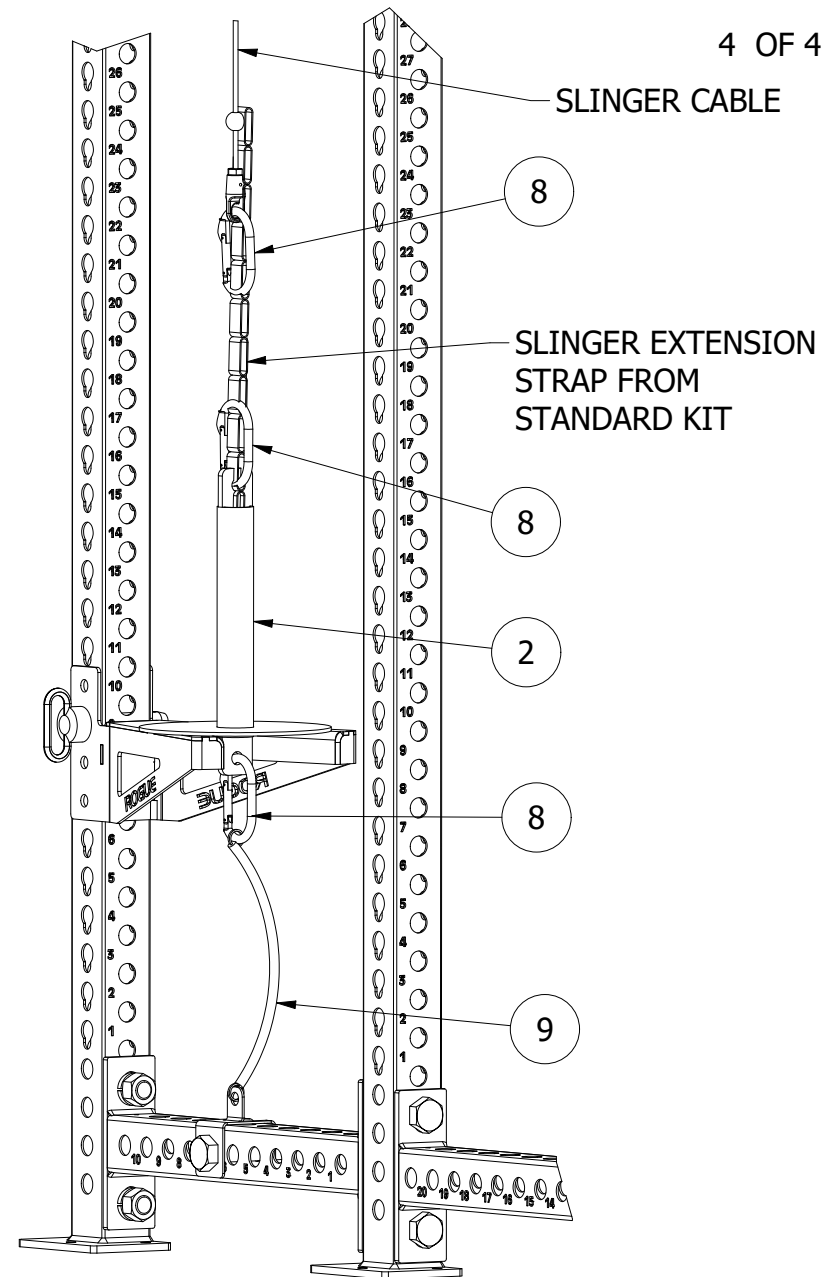

DISCLAIMER

Resistance training, gymnastics training, and activities at height are potentially dangerous and may lead to severe injury or even death. Use common sense when training, to obtain instruction in the proper execution of movements, and understand your limitations. This equipment must only be used by competent and responsible persons, or under the direct and visual control of a competent and responsible person. Obtaining instruction in appropriate techniques and methods of use is your own responsibility. You assume all risks and responsibilities for all damage, injury or death which may occur during or following incorrect use of this equipment in any matter whatsoever. Rogue Fitness bears no liability beyond the replacement value of the equipment in question.



MISUSE OF THIS CAN RESULT IN SEVERE INJURY

BOTH ROGUE FITNESS AND BUYER DISCLAIM ANY EXPRESS OR IMPLIED WARRANTY, INCLUDING, WITHOUT LIMITATION, WARRANTIES OR MERCHANTABILITY AND/OR FITNESS FOR A PARTICULAR PURPOSE WITH RESPECT TO THE EQUIPMENT. BUYER ASSUMES ALL LIABILITY IN USE OF EQUIPMENT.

R
Rogue Fitness
545 E 5th Ave.
Columbus, Ohio 43201
614-358-6190
team@roguefitness.com