

ROGUE

Monster Hip Thruster Bench

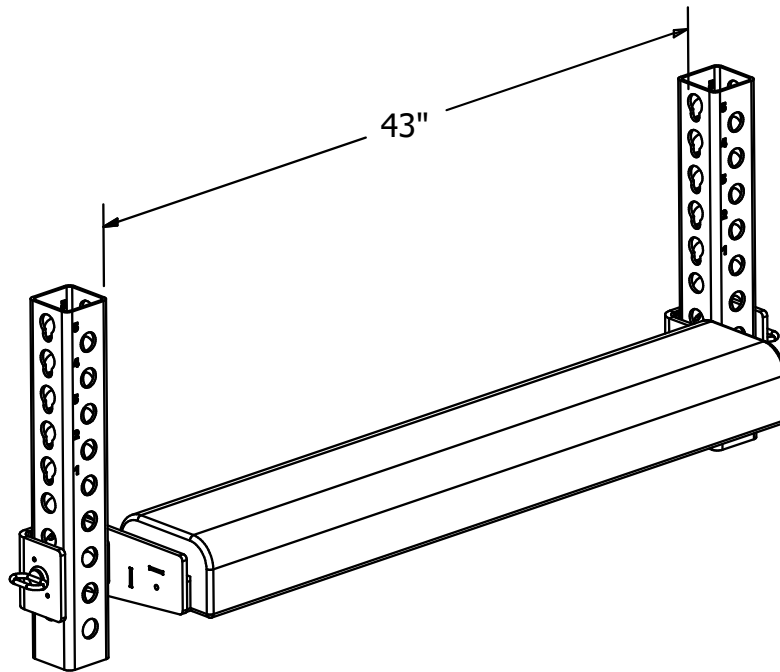

GENERAL GUIDELINES:

- PLEASE READ THESE CUSTOMER INSTRUCTIONS THOROUGHLY PRIOR TO ASSEMBLING.

Note : The Monster Hip Thruster Bench is designed to fit within a 43" space (from inside of upright to inside of upright). If the Hip Thruster Bench seems too short or too long, please first ensure that the uprights being mounted to measure 43" from inside face to inside face.

DISCLAIMER

Resistance training, gymnastics training, and activities at height are potentially dangerous and may lead to severe injury or even death. Use common sense when training, to obtain instruction in the proper execution of movements, and understand your limitations. This equipment must only be used by competent and responsible persons, or under the direct and visual control of a competent and responsible person. Obtaining instruction in appropriate techniques and methods of use is your own responsibility. You assume all risks and responsibilities for all damage, injury or death which may occur during or following incorrect use of this equipment in any matter whatsoever. Rogue Fitness bears no liability beyond the replacement value of the equipment in question.

* SEE SHEET 2 FOR ITEM DESCRIPTIONS AND QUANTITIES *



WARNING!



MISUSE OF THIS CAN RESULT IN
SEVERE INJURY

BOTH ROGUE FITNESS AND BUYER DISCLAIM ANY EXPRESS OR IMPLIED WARRANTY, INCLUDING, WITHOUT LIMITATION, WARRANTIES OR MERCHANTABILITY AND/OR FITNESS FOR A PARTICULAR PURPOSE WITH RESPECT TO THE EQUIPMENT. BUYER ASSUMES ALL LIABILITY IN USE OF EQUIPMENT.

Rogue Fitness
545 E 5th Ave.
Columbus, Ohio 43201
614-358-6190
team@roguefitness.com

ROGUE

Monster Hip Thruster Bench

INCLUDED PARTS
*NOTE: IMAGES NOT SHOWN TO SCALE

PARTS LIST		
ITEM	QTY	PART NUMBER
1	1	Monster Hip Thruster Bench
2	2	1" x 4-1/2" Detent Pin

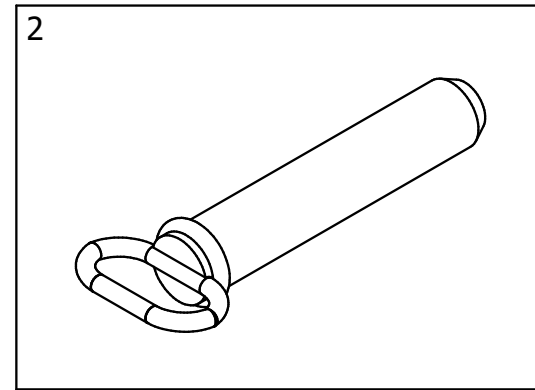
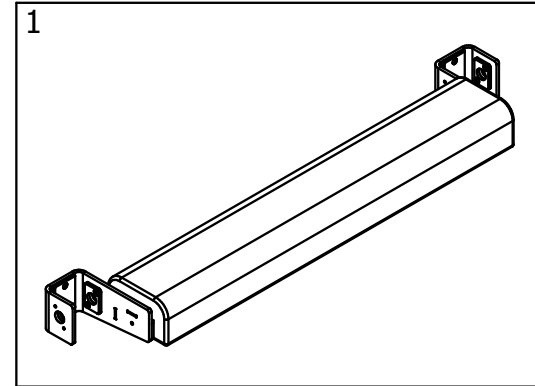

DISCLAIMER

Resistance training, gymnastics training, and activities at height are potentially dangerous and may lead to severe injury or even death. Use common sense when training, to obtain instruction in the proper execution of movements, and understand your limitations. This equipment must only be used by competent and responsible persons, or under the direct and visual control of a competent and responsible person. Obtaining instruction in appropriate techniques and methods of use is your own responsibility. You assume all risks and responsibilities for all damage, injury or death which may occur during or following incorrect use of this equipment in any matter whatsoever. Rogue Fitness bears no liability beyond the replacement value of the equipment in question.



MISUSE OF THIS CAN RESULT IN
SEVERE INJURY

BOTH ROGUE FITNESS AND BUYER DISCLAIM ANY EXPRESS OR IMPLIED WARRANTY, INCLUDING, WITHOUT LIMITATION, WARRANTIES OR MERCHANTABILITY AND/OR FITNESS FOR A PARTICULAR PURPOSE WITH RESPECT TO THE EQUIPMENT. BUYER ASSUMES ALL LIABILITY IN USE OF EQUIPMENT.

Rogue Fitness
545 E 5th Ave.
Columbus, Ohio 43201
614-358-6190
team@roguefitness.com

ROGUE

Monster Hip Thruster Bench

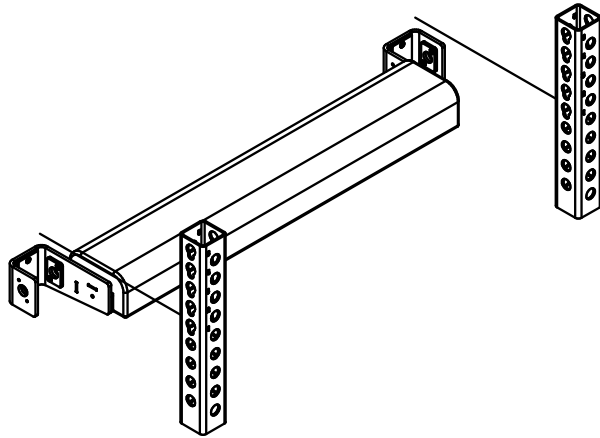

Step 1: Line the Monster Hip Thruster Bench up with the rack at the desired height.

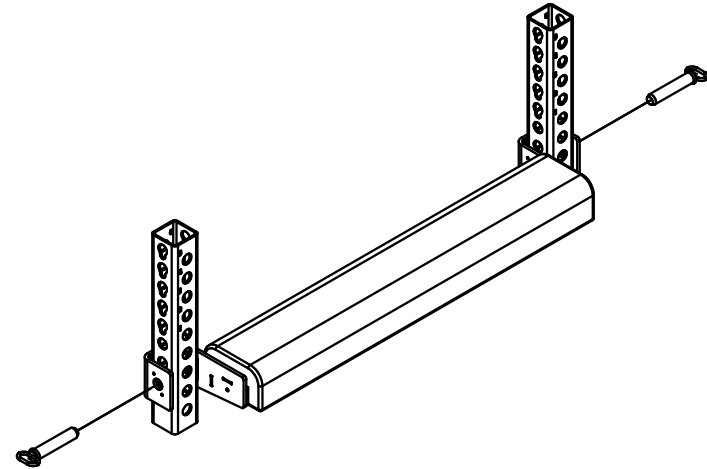

Step 2: At the desired height, insert both 1" x 4-1/2" Detent Pins through the rack and the Monster Hip Thruster Bench from to outside of the rack toward the inside of the rack.

DISCLAIMER

Resistance training, gymnastics training, and activities at height are potentially dangerous and may lead to severe injury or even death. Use common sense when training, to obtain instruction in the proper execution of movements, and understand your limitations. This equipment must only be used by competent and responsible persons, or under the direct and visual control of a competent and responsible person. Obtaining instruction in appropriate techniques and methods of use is your own responsibility. You assume all risks and responsibilities for all damage, injury or death which may occur during or following incorrect use of this equipment in any matter whatsoever. Rogue Fitness bears no liability beyond the replacement value of the equipment in question.



MISUSE OF THIS CAN RESULT IN SEVERE INJURY

BOTH ROGUE FITNESS AND BUYER DISCLAIM ANY EXPRESS OR IMPLIED WARRANTY, INCLUDING, WITHOUT LIMITATION, WARRANTIES OR MERCHANTABILITY AND/OR FITNESS FOR A PARTICULAR PURPOSE WITH RESPECT TO THE EQUIPMENT. BUYER ASSUMES ALL LIABILITY IN USE OF EQUIPMENT.

Rogue Fitness
545 E 5th Ave.
Columbus, Ohio 43201
614-358-6190
team@roguefitness.com