

ROGUE

MONSTER WEIGHT STACK SLINGER

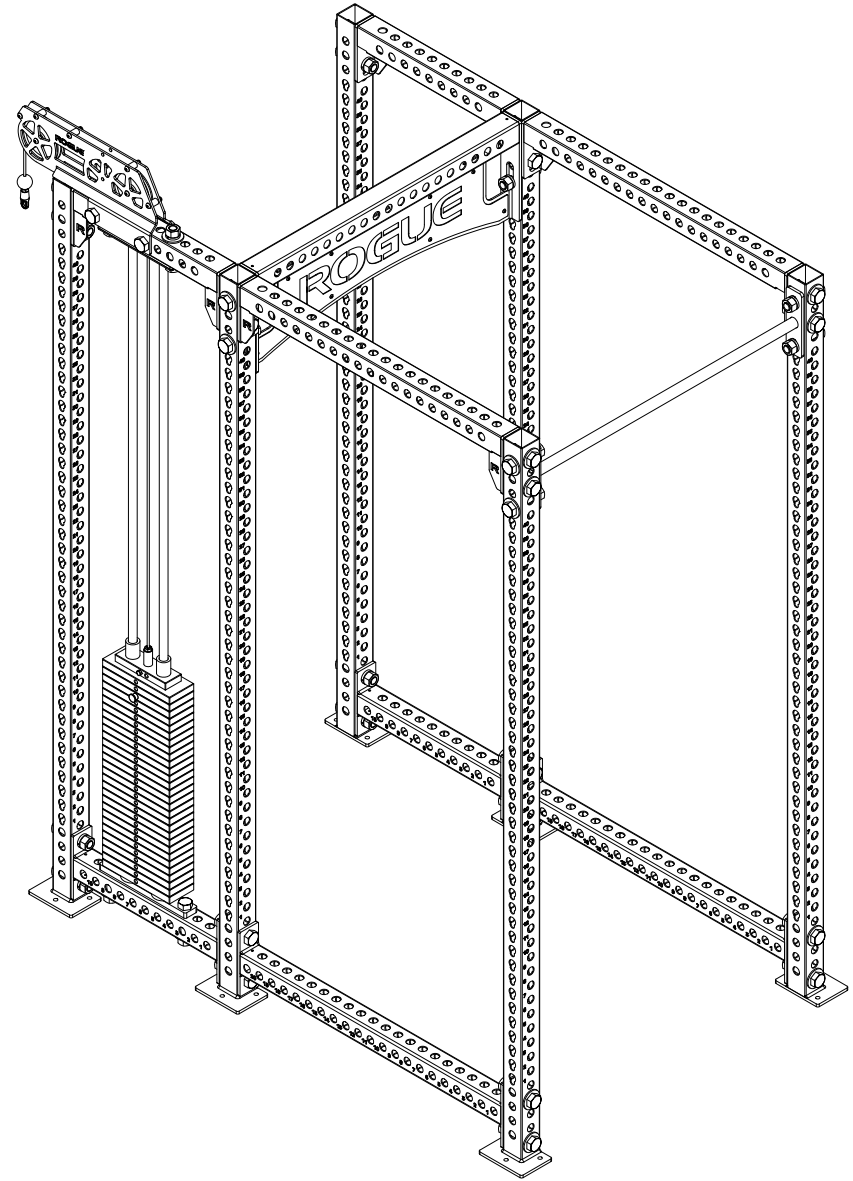

WARNING:
ANY RACK OR RIG UTILIZING THE
SLINGER ATTACHMENT MUST BE SECURELY
FASTENED TO THE FLOOR FOR USE.

DISCLAIMER

Resistance training, gymnastics training, and activities at height are potentially dangerous and may lead to severe injury or even death. Use common sense when training, to obtain instruction in the proper execution of movements, and understand your limitations. This equipment must only be used by competent and responsible persons, or under the direct and visual control of a competent and responsible person. Obtaining instruction in appropriate techniques and methods of use is your own responsibility. You assume all risks and responsibilities for all damage, injury or death which may occur during or following incorrect use of this equipment in any matter whatsoever. Rogue Fitness bears no liability beyond the replacement value of the equipment in question.



MISUSE OF THIS CAN RESULT IN
SEVERE INJURY

BOTH ROGUE FITNESS AND BUYER DISCLAIM ANY EXPRESS OR IMPLIED WARRANTY, INCLUDING, WITHOUT LIMITATION, WARRANTIES OR MERCHANTABILITY AND/OR FITNESS FOR A PARTICULAR PURPOSE WITH RESPECT TO THE EQUIPMENT. BUYER ASSUMES ALL LIABILITY IN USE OF EQUIPMENT.

Rogue Fitness
545 E 5th Ave.
Columbus, Ohio 43201
614-358-6190
team@roguefitness.com