

ROGUE

MONSTER SINGLE SIDE LEAN-TO BAR RACK

GENERAL GUIDELINES:

- PLEASE READ THESE CUSTOMER INSTRUCTIONS THOROUGHLY PRIOR TO ASSEMBLING.

TOOLS REQUIRED:

- 1-1/2" Wrench/Socket
- 7/16" Wrench/Socket
- 5/32" Hex Key

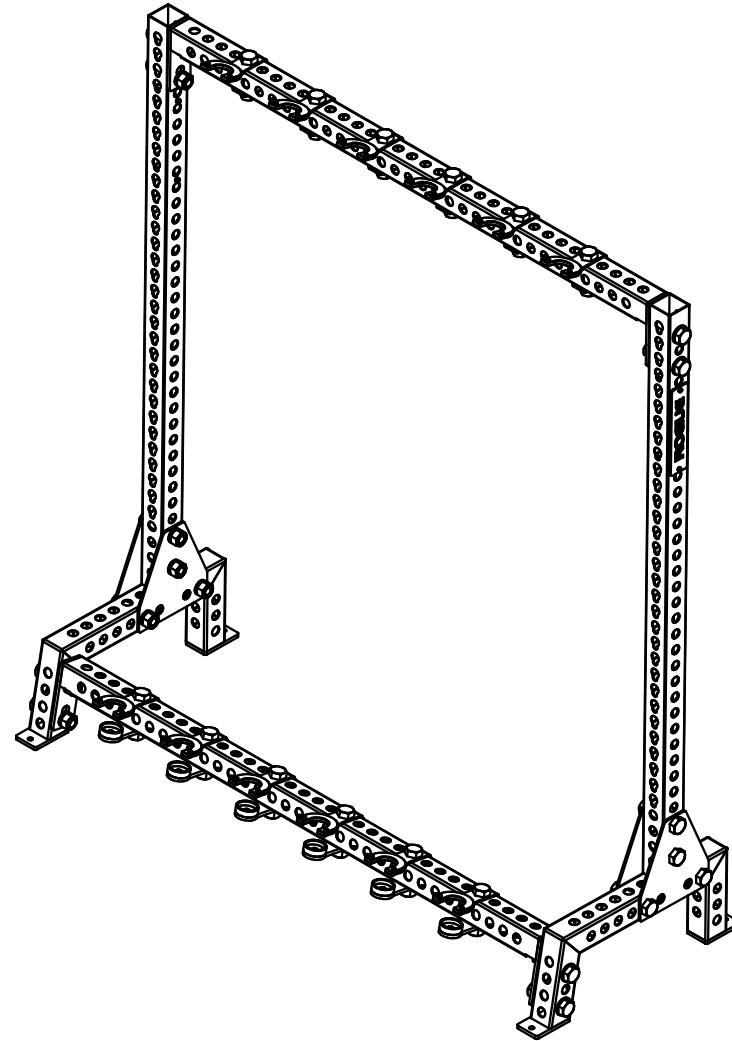

* SEE SHEET 2 FOR ITEM DESCRIPTIONS AND QUANTITIES *

DISCLAIMER

Resistance training, gymnastics training, and activities at height are potentially dangerous and may lead to severe injury or even death. Use common sense when training, to obtain instruction in the proper execution of movements, and understand your limitations. This equipment must only be used by competent and responsible persons, or under the direct and visual control of a competent and responsible person. Obtaining instruction in appropriate techniques and methods of use is your own responsibility. You assume all risks and responsibilities for all damage, injury or death which may occur during or following incorrect use of this equipment in any matter whatsoever. Rogue Fitness bears no liability beyond the replacement value of the equipment in question.



MISUSE OF THIS CAN RESULT IN
SEVERE INJURY

BOTH ROGUE FITNESS AND BUYER DISCLAIM ANY EXPRESS OR IMPLIED WARRANTY, INCLUDING, WITHOUT LIMITATION, WARRANTIES OR MERCHANTABILITY AND/OR FITNESS FOR A PARTICULAR PURPOSE WITH RESPECT TO THE EQUIPMENT. BUYER ASSUMES ALL LIABILITY IN USE OF EQUIPMENT.

Rogue Fitness
545 E 5th Ave.
Columbus, Ohio 43201
614-358-6190
team@roguefitness.com

ROGUE

MONSTER SINGLE SIDE LEAN-TO BAR RACK

INCLUDED PARTS
*NOTE: IMAGES NOT SHOWN TO SCALE

PARTS LIST		
ITEM	QTY	PART NUMBER
1	4	Triangle Plate
2	2	Rogue Nameplate
3	2	SS Nameplate Backer
4	8	1" Flat Washer
5	28	1" x 4-3/4" Hex Bolt
6	28	1" Spring Lock Washer
7	28	1" Hex Nut
8	4	1/4" Flange Locknut
9	4	1/4" x 3-1/2" Button Head Screw
10	2	Base Foot
11	2	Crossmember
12	2	Upright
13	6	Bottom Bar Socket Formed Piece
14	6	Bottom Bar Socket Flat Piece
15	6	Top Bar Socket

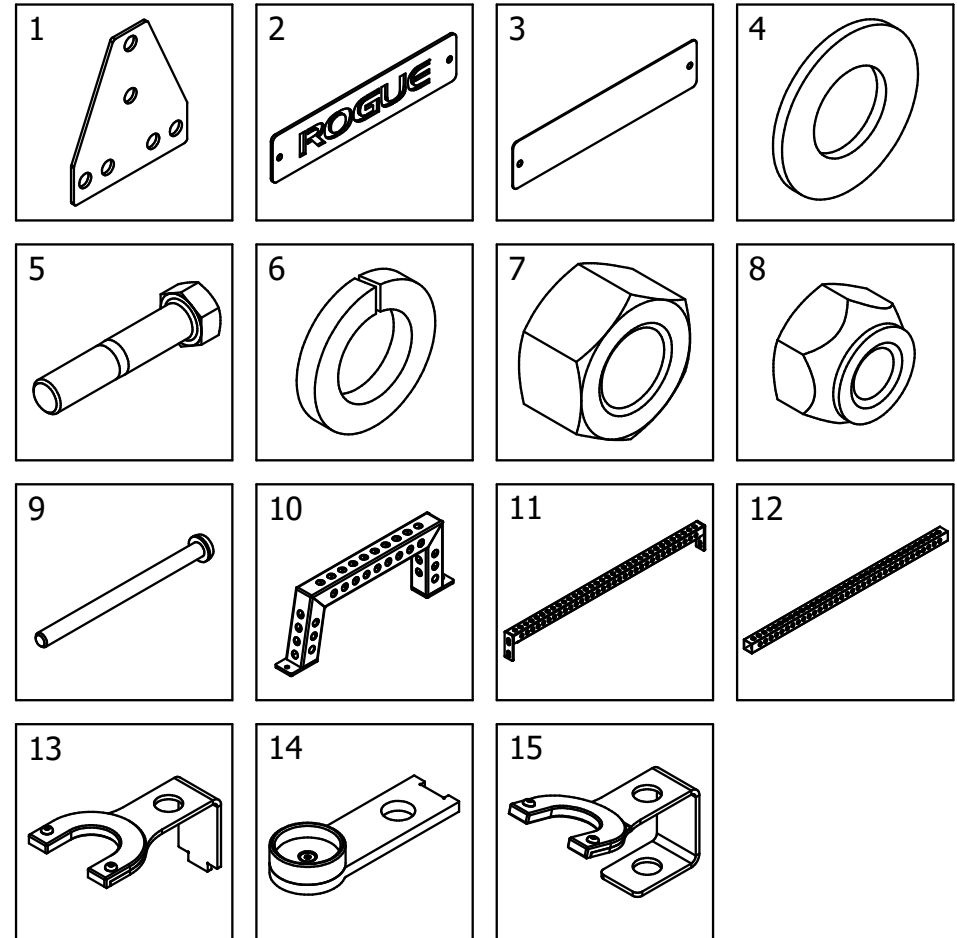

DISCLAIMER

Resistance training, gymnastics training, and activities at height are potentially dangerous and may lead to severe injury or even death. Use common sense when training, to obtain instruction in the proper execution of movements, and understand your limitations. This equipment must only be used by competent and responsible persons, or under the direct and visual control of a competent and responsible person. Obtaining instruction in appropriate techniques and methods of use is your own responsibility. You assume all risks and responsibilities for all damage, injury or death which may occur during or following incorrect use of this equipment in any matter whatsoever. Rogue Fitness bears no liability beyond the replacement value of the equipment in question.



WARNING!



MISUSE OF THIS CAN RESULT IN SEVERE INJURY

BOTH ROGUE FITNESS AND BUYER DISCLAIM ANY EXPRESS OR IMPLIED WARRANTY, INCLUDING, WITHOUT LIMITATION, WARRANTIES OR MERCHANTABILITY AND/OR FITNESS FOR A PARTICULAR PURPOSE WITH RESPECT TO THE EQUIPMENT. BUYER ASSUMES ALL LIABILITY IN USE OF EQUIPMENT.

Rogue Fitness
545 E 5th Ave.
Columbus, Ohio 43201
614-358-6190
team@roguefitness.com

ROGUE

MONSTER SINGLE SIDE LEAN-TO BAR RACK

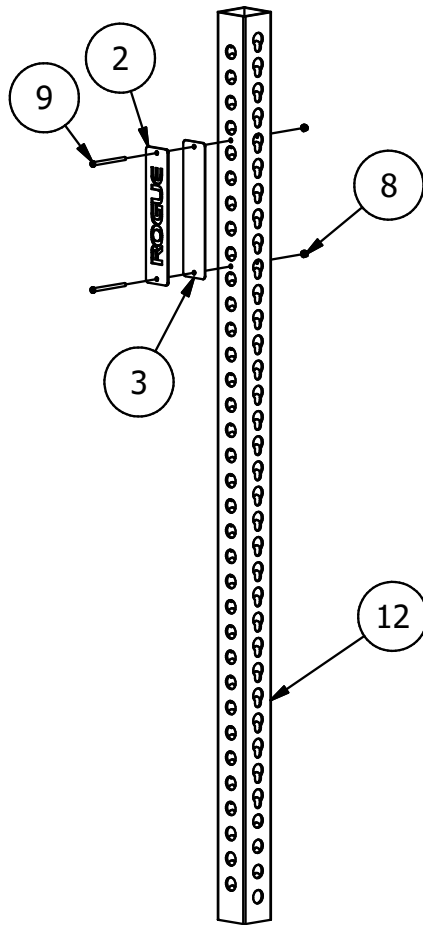

Step 1: Attach the Rogue Nameplates and Stainless Steel Backers to the Uprights using 1/4" x 3-1/2" Button Head Screws and 1/4" Flange Locknuts.

NOTE: The Uprights have 0.28" holes for the Rogue Nameplate to be attached.

Step 2: Attach the Uprights to the Base Feet using the Triangle Plates, 1" x 4-3/4" Hex Bolts, 1" Spring Lock Washers, and 1" Hex Nuts. Repeat for both Uprights/Base Feet. (Loosely hand tighten only)

NOTE: The outside hole of the Triangle Plates should be aligned with the last hole on the top of the Base Foot.

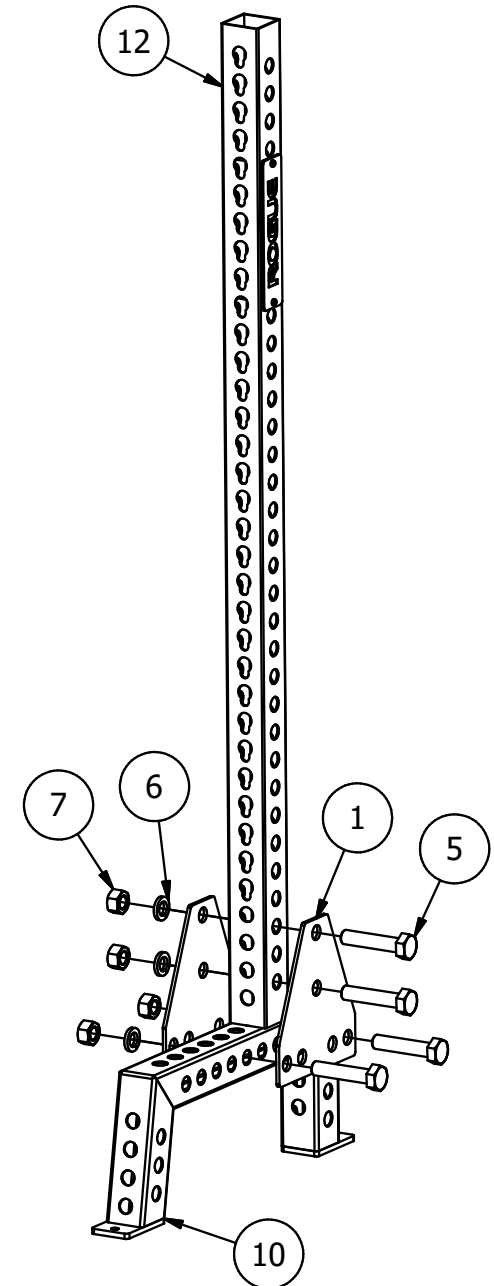
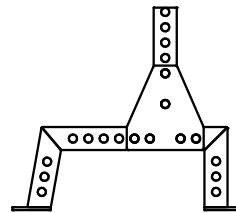

DISCLAIMER

Resistance training, gymnastics training, and activities at height are potentially dangerous and may lead to severe injury or even death. Use common sense when training, to obtain instruction in the proper execution of movements, and understand your limitations. This equipment must only be used by competent and responsible persons, or under the direct and visual control of a competent and responsible person. Obtaining instruction in appropriate techniques and methods of use is your own responsibility. You assume all risks and responsibilities for all damage, injury or death which may occur during or following incorrect use of this equipment in any matter whatsoever. Rogue Fitness bears no liability beyond the replacement value of the equipment in question.



WARNING!

MISUSE OF THIS CAN RESULT IN SEVERE INJURY

BOTH ROGUE FITNESS AND BUYER DISCLAIM ANY EXPRESS OR IMPLIED WARRANTY, INCLUDING, WITHOUT LIMITATION, WARRANTIES OR MERCHANTABILITY AND/OR FITNESS FOR A PARTICULAR PURPOSE WITH RESPECT TO THE EQUIPMENT. BUYER ASSUMES ALL LIABILITY IN USE OF EQUIPMENT.

Rogue Fitness
545 E 5th Ave.
Columbus, Ohio 43201
614-358-6190
team@roguefitness.com

ROGUE

MONSTER SINGLE SIDE LEAN-TO BAR RACK

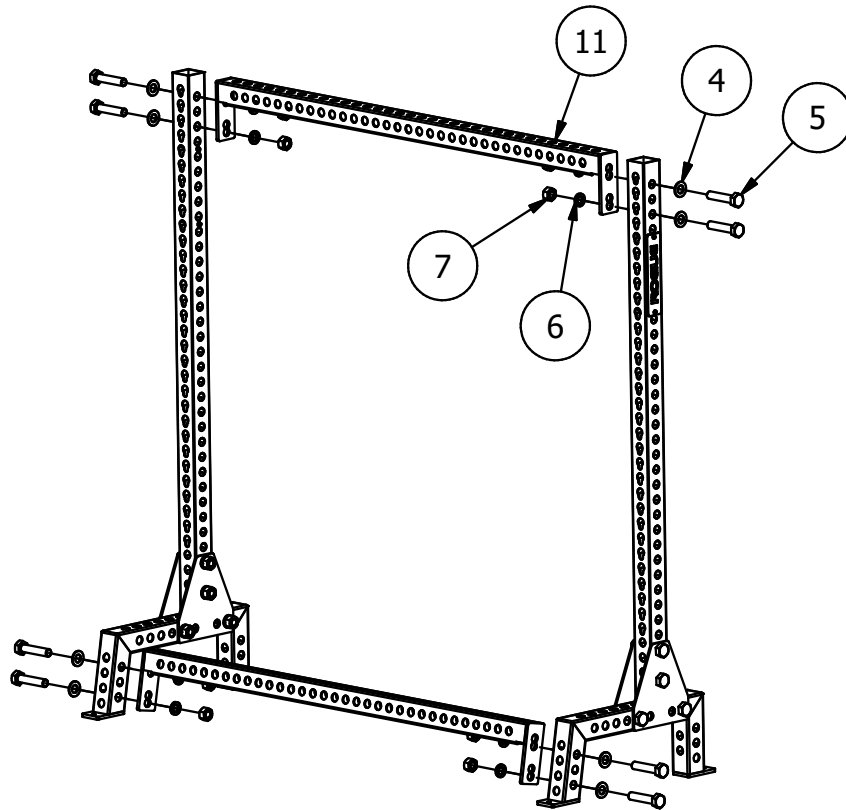

Step 3: Attach a Crossmember to the top of the upright using 1" x 4-3/4" Hex Bolts, 1" Flat Washers, 1" Spring Lock Washers, and 1" Hex Nuts. The top of the Crossmember should sit flush with the top of the Uprights. (Loosely hand tighten only.)

Step 4: Attach a Crossmember to the Base Feet using 1" x 4-3/4" Hex Bolts, 1" Flat Washers, 1" Spring Lock Washers, and 1" Hex Nuts. Use the bottom of the connected holes on the Crossmember end plate when performing this step. (Hardware can now be fully tightened.)

DISCLAIMER

Resistance training, gymnastics training, and activities at height are potentially dangerous and may lead to severe injury or even death. Use common sense when training, to obtain instruction in the proper execution of movements, and understand your limitations. This equipment must only be used by competent and responsible persons, or under the direct and visual control of a competent and responsible person. Obtaining instruction in appropriate techniques and methods of use is your own responsibility. You assume all risks and responsibilities for all damage, injury or death which may occur during or following incorrect use of this equipment in any matter whatsoever. Rogue Fitness bears no liability beyond the replacement value of the equipment in question.



MISUSE OF THIS CAN RESULT IN
SEVERE INJURY

BOTH ROGUE FITNESS AND BUYER DISCLAIM ANY EXPRESS OR IMPLIED WARRANTY, INCLUDING, WITHOUT LIMITATION, WARRANTIES OR MERCHANTABILITY AND/OR FITNESS FOR A PARTICULAR PURPOSE WITH RESPECT TO THE EQUIPMENT. BUYER ASSUMES ALL LIABILITY IN USE OF EQUIPMENT.

Rogue Fitness
545 E 5th Ave.
Columbus, Ohio 43201
614-358-6190
team@roguefitness.com

ROGUE

MONSTER SINGLE SIDE LEAN-TO BAR RACK

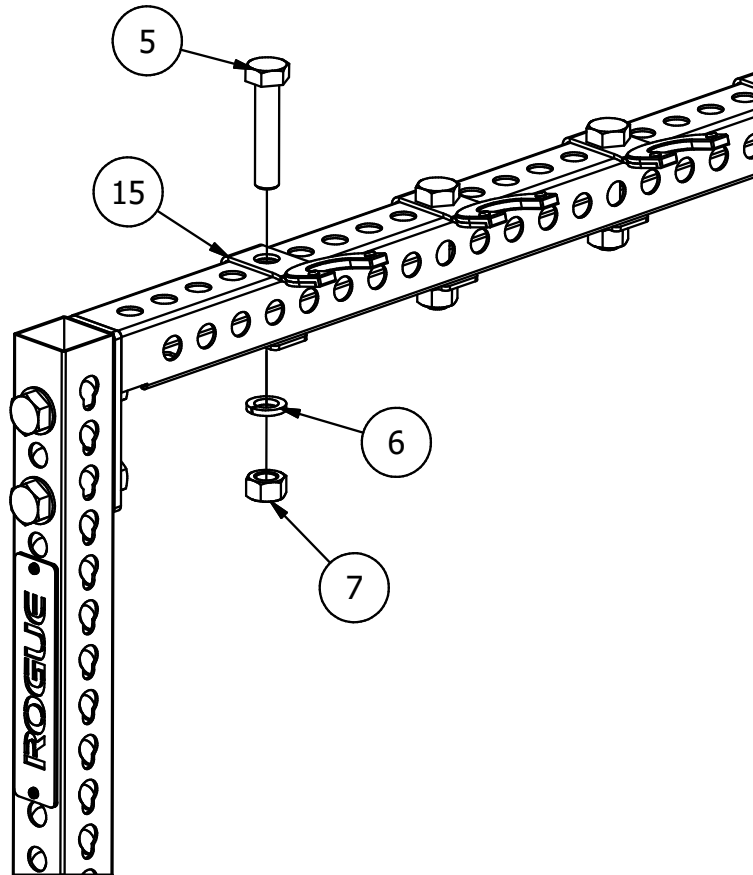

Step 5: Attach the Top Bar Sockets to the top Crossmember using 1" x 4-3/4" Hex Bolts, 1" Spring Lock Washers, and 1" Hex Nuts.

NOTE: The Top Attachments can be attached anywhere on the top crossmember. However, we recommend either spacing them 5 holes apart (for trap bar storage) or 3 holes apart (for barbell storage).

DISCLAIMER

Resistance training, gymnastics training, and activities at height are potentially dangerous and may lead to severe injury or even death. Use common sense when training, to obtain instruction in the proper execution of movements, and understand your limitations. This equipment must only be used by competent and responsible persons, or under the direct and visual control of a competent and responsible person. Obtaining instruction in appropriate techniques and methods of use is your own responsibility. You assume all risks and responsibilities for all damage, injury or death which may occur during or following incorrect use of this equipment in any matter whatsoever. Rogue Fitness bears no liability beyond the replacement value of the equipment in question.



WARNING!

MISUSE OF THIS CAN RESULT IN
SEVERE INJURY

BOTH ROGUE FITNESS AND BUYER DISCLAIM ANY EXPRESS OR IMPLIED WARRANTY, INCLUDING, WITHOUT LIMITATION, WARRANTIES OR MERCHANTABILITY AND/OR FITNESS FOR A PARTICULAR PURPOSE WITH RESPECT TO THE EQUIPMENT. BUYER ASSUMES ALL LIABILITY IN USE OF EQUIPMENT.

Rogue Fitness
545 E 5th Ave.
Columbus, Ohio 43201
614-358-6190
team@roguefitness.com

ROGUE

MONSTER SINGLE SIDE LEAN-TO BAR RACK

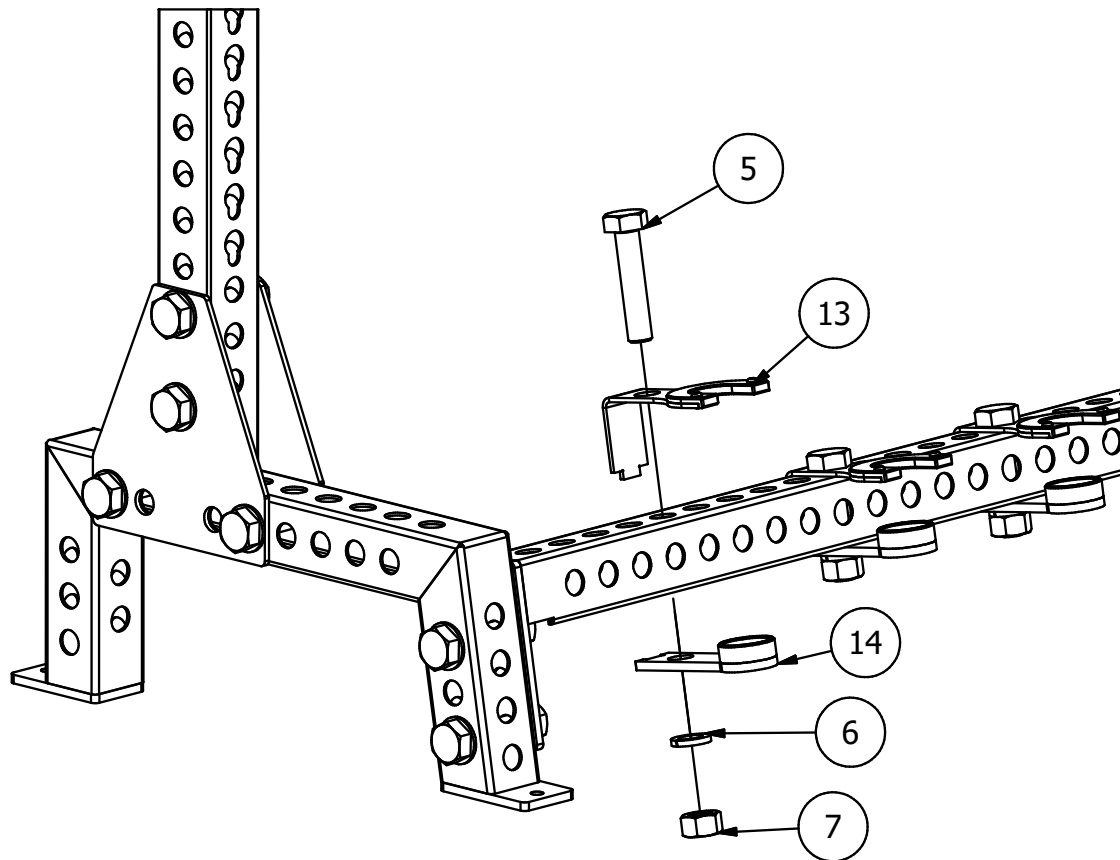

Step 5: Attach the Bottom Bar Socket Formed Pieces and the Bottom Bar Socket Flat Pieces to the bottom Bar Socket Flat Pieces to the bottom Crossmember using 1" x 4-3/4" Hex Bolts, 1" Spring Lock Washers, and 1" Hex Nuts. The specific crossmember and hole location of the Bottom Bar Sockets will be determined by the position of the Top Bar Sockets chosen in the previous step.

DISCLAIMER

Resistance training, gymnastics training, and activities at height are potentially dangerous and may lead to severe injury or even death. Use common sense when training, to obtain instruction in the proper execution of movements, and understand your limitations. This equipment must only be used by competent and responsible persons, or under the direct and visual control of a competent and responsible person. Obtaining instruction in appropriate techniques and methods of use is your own responsibility. You assume all risks and responsibilities for all damage, injury or death which may occur during or following incorrect use of this equipment in any matter whatsoever. Rogue Fitness bears no liability beyond the replacement value of the equipment in question.



MISUSE OF THIS CAN RESULT IN
SEVERE INJURY

BOTH ROGUE FITNESS AND BUYER DISCLAIM ANY EXPRESS OR IMPLIED WARRANTY, INCLUDING, WITHOUT LIMITATION, WARRANTIES OR MERCHANTABILITY AND/OR FITNESS FOR A PARTICULAR PURPOSE WITH RESPECT TO THE EQUIPMENT. BUYER ASSUMES ALL LIABILITY IN USE OF EQUIPMENT.

Rogue Fitness
545 E 5th Ave.
Columbus, Ohio 43201
614-358-6190
team@roguefitness.com