

GHOST STRONG HD & COMP PR COMBO RACK INSTRUCTIONS:

STEP 1:

- INSERT SLIP BAR INTO LEFT LOWER FRAME AND HAND TIGHTEN (2) THUMB SCREWS.
- INSERT RIGHT LOWER FRAME IN OTHER END OF SLIP BAR AND HAND TIGHTEN (2) THUMB SCREWS.

STEP 2:

- INSERT LEFT UPRIGHT W/ LEVER ARM (GHOST STICKERS FACING OUTWARD) INTO LEFT LOWER FRAME AND INSTALL (1) QUICK RELEASE PIN.
- INSTALL CAM LINKAGE (WITH TAPPED HOLE ON TOP) AND INSERT INTO THE BOTTOM OF THE SMALL CHANNEL PIECE (BELOW THE QUICK RELEASE PIN) THEN THREAD (1) CAM LINK THUMB SCREW INTO THE TAPPED HOLE OF THE CAM LINKAGE.
- INSTALL CAM SO THREADED STUD IS VISIBLE THROUGH THE CENTER HOLE AND THE DOWEL GOES INTO SLOT ON FRONT OF CONNECTION JOINT AND INTO UPRIGHT TUBE.
- LOOSEN CAM LINK THUMB SCREW AND LOWER CAM LINKAGE INTO LEFT NOTCH IN THE CAM, THEN SCREW CAM LOCK ONTO THREADED STUD AND HAND TIGHTEN. (THIS WILL PUT THE UPRIGHT IN THE VERTICAL POSITION)
- PLACE (1) PIN INTO THE HORIZONTAL TUBE NEAR THE LEVER ARM.

(REPEAT STEP 2 FOR RIGHT SIDE)

NOTE: TO TILT UPRIGHT INWARD, LOOSEN THE CAM LOCK AND LIFT CAM LINKAGE OUT OF THE NOTCH ON THE CAM, THEN SNUG CAM LINK THUMB SCREW TO HOLD IT IN PLACE. TILT UPRIGHT INWARD AND LOOSEN CAM LINK THUMB SCREW AND DROP CAM LINKAGE INTO NOTCH ON CAM, THEN HAND TIGHTEN CAM LOCK.

STEP 3:

- INSERT LEFT SAFETY FRAME (BAND PEGS OUTWARD) INTO SQUARE OPENING ON THE FRONT OF THE LEFT LOWER FRAME AND HAND TIGHTEN (1) THUMB SCREW TO LOCK IN PLACE AT CONNECTION.

(REPEAT STEP 3 FOR RIGHT SAFETY FRAME)

STEP 4:

- INSERT LEFT J-CUP UPRIGHT (SMALL GHOST STICKERS FACING INWARD) INTO LEFT UPRIGHT W/ LEVER ARM AND USE (1) PIN TO ADJUST TO DESIRED HEIGHT.
- INSERT LEFT SAFETY ARM (NUMBERS FACING INWARD) INTO LEFT SAFETY FRAME AND USE (1) PIN TO ADJUST TO DESIRED HEIGHT, THEN HAND TIGHTEN (1) THUMB SCREW INTO THE TAPPED BOSS ON THE VERTICAL TUBE OF THE SAFETY FRAME.

(REPEAT STEP 4 FOR RIGHT SIDE)

STEP 5:

- ATTACH AND SECURE BENCH PAD FRAME TO SPOTTER CROSS-MEMBER USING (3) THUMB SCREWS.
- LIFT FRONT OF BENCH PAD FRAME AND SPOTTER CROSS-MEMBER AND ROLL INTO POSITION AND LOWER DOWN SO THAT THE TABS ON THE BOTTOM OF THE PLATES AT EACH END OF THE SPOTTER CROSS-MEMBER DROP INTO THE RECTANGULAR OPENINGS ON THE LOWER FRAMES, THEN SECURE WITH (2) THUMB SCREWS.

ASSEMBLY IS COMPLETE - SEE PAGE 2 FOR A COMPLETELY ASSEMBLED COMBO RACK.



ASSEMBLY INSTRUCTIONS

HD & COMP PR COMBO RACK

PAGE 1 OF 2

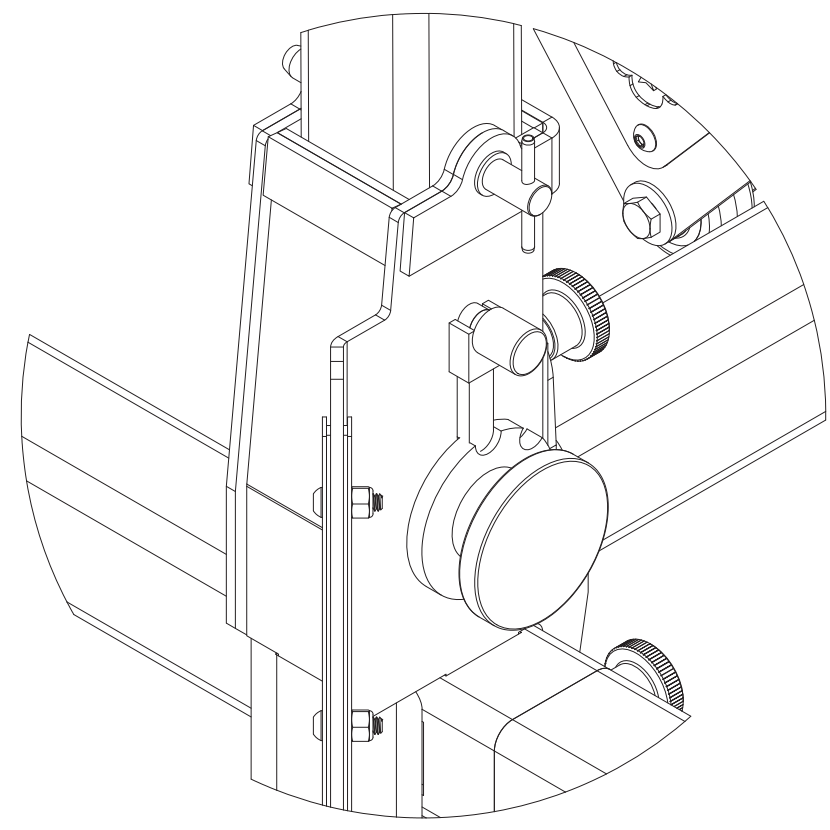

DETAIL A

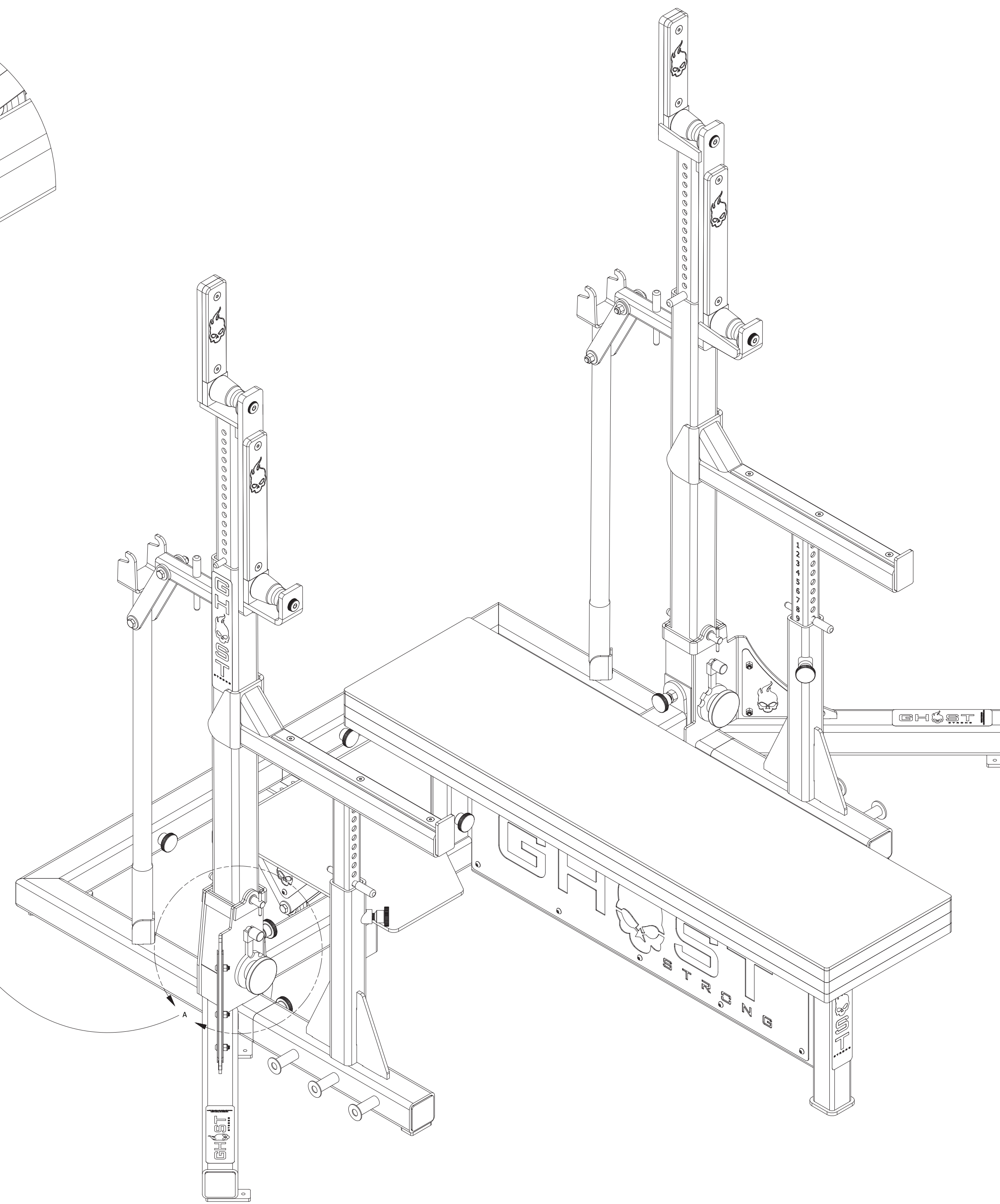

ASSEMBLY INSTRUCTIONS
HD & COMP PR COMBO RACK