

ROGUE®

MONSTER LITE

PRITCHETT PAD

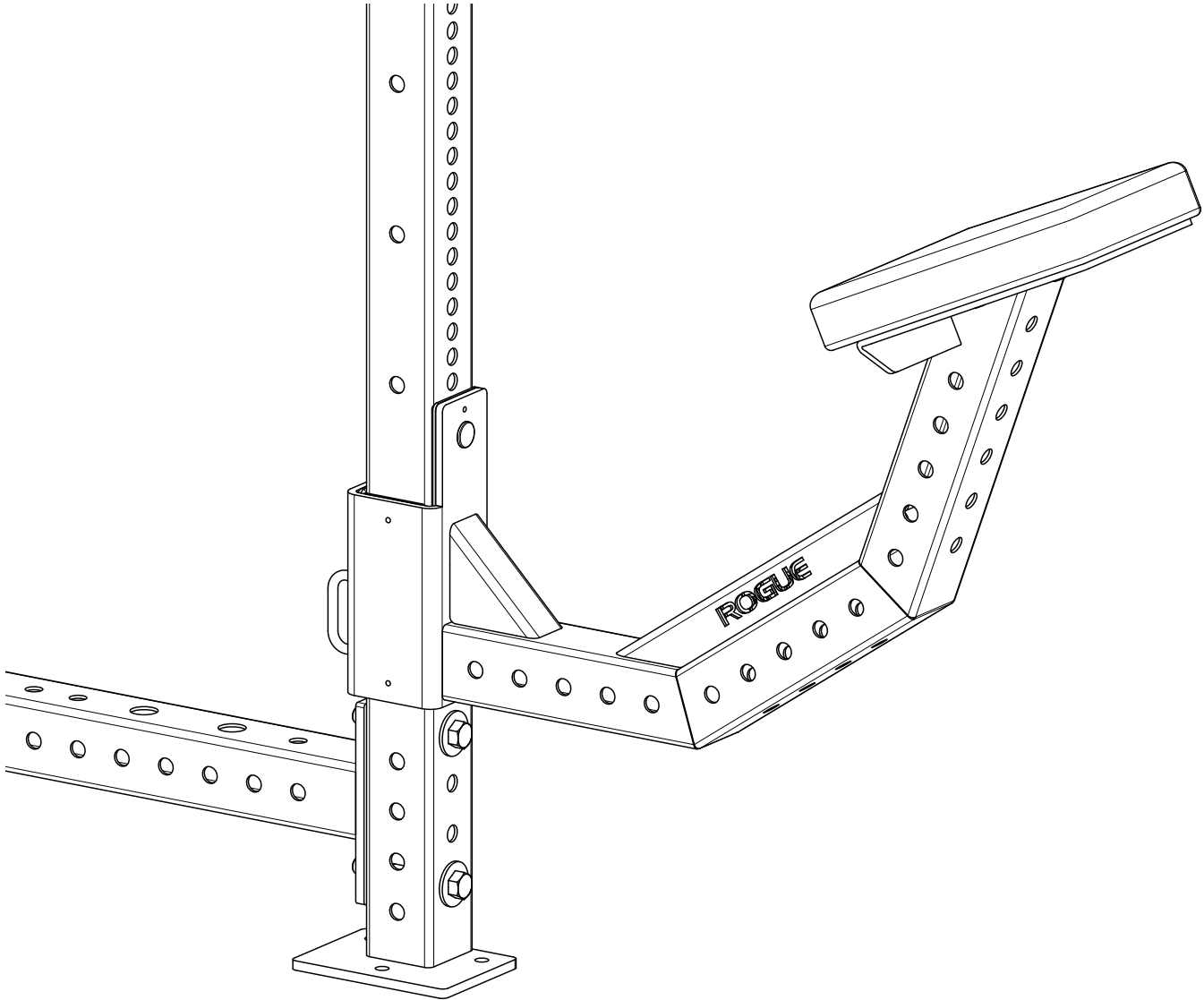

IMPORTANT SAFETY INFORMATION

DISCLAIMER:

Resistance training, gymnastics training, and activities at height are potentially dangerous and may lead to severe injury or even death. Use common sense when training, obtain instruction in the proper execution of movements, and understand your limitations. This equipment must only be used by competent and responsible persons. Obtaining instruction in appropriate techniques and methods of use is your own responsibility. You assume all risks and responsibilities for all damage, injury or death which may occur during or following incorrect use of this equipment in any matter whatsoever. Rogue Fitness bears no liability beyond the replacement value of the equipment in question.

WARNING:

MISUSE OF THIS CAN RESULT IN SEVERE INJURY.

Both Rogue Fitness and buyer disclaim any express or implied warranty, including, without limitation, warranties or merchantability and/or fitness for a particular purpose with respect to the equipment. Buyer assumes all liability to use of equipment.

INCLUDED PARTS

Note: Images not shown at scale

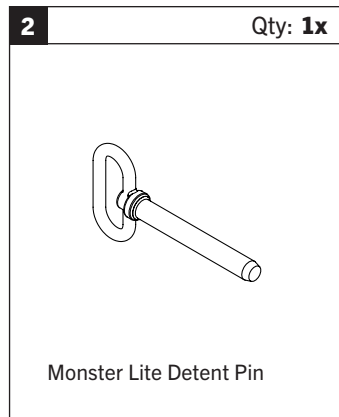
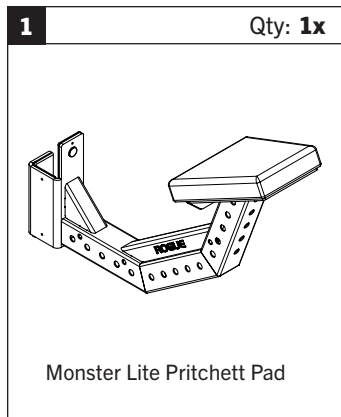

STEP 1

- Insert Monster Lite Pritchett Pad into hole at desired height on the front left upright of Monster Lite rack.

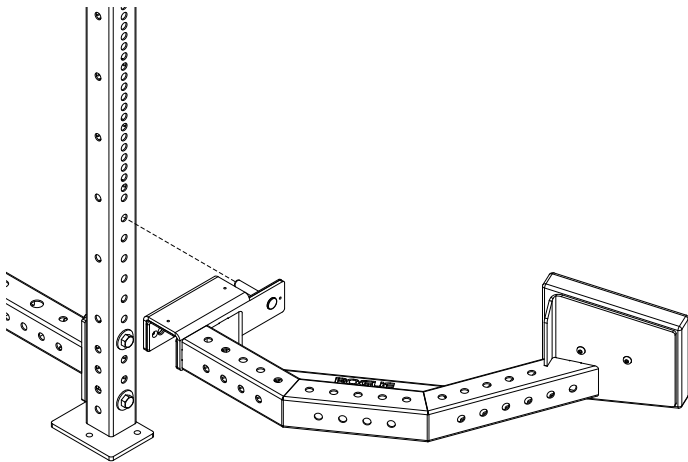

STEP 2

- Carefully rotate unit down into place and always secure using provided Monster Lite Detent Pin.

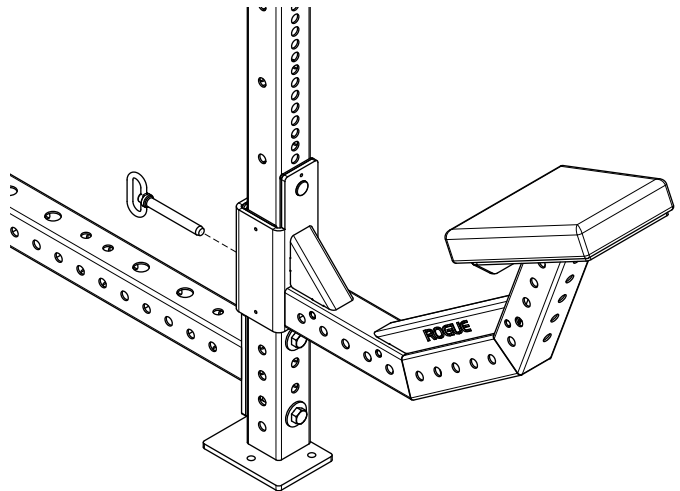

STEP 3

- We recommend using your Pritchett Pad with a rack-mounted landmine and landmine handle for optimal performance.

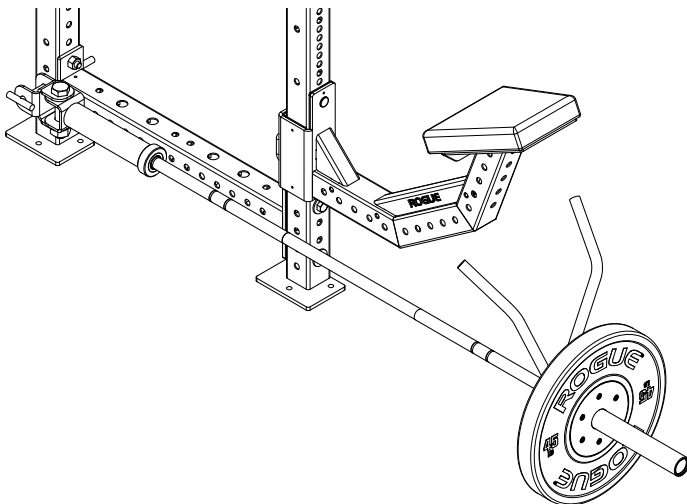

WARNING!

- Rack must be bolted to floor prior to using Pritchett Pad. Concrete anchors can be purchased at roguefitness.com.

