

ROGUE®

CTM-1 BAND PEG

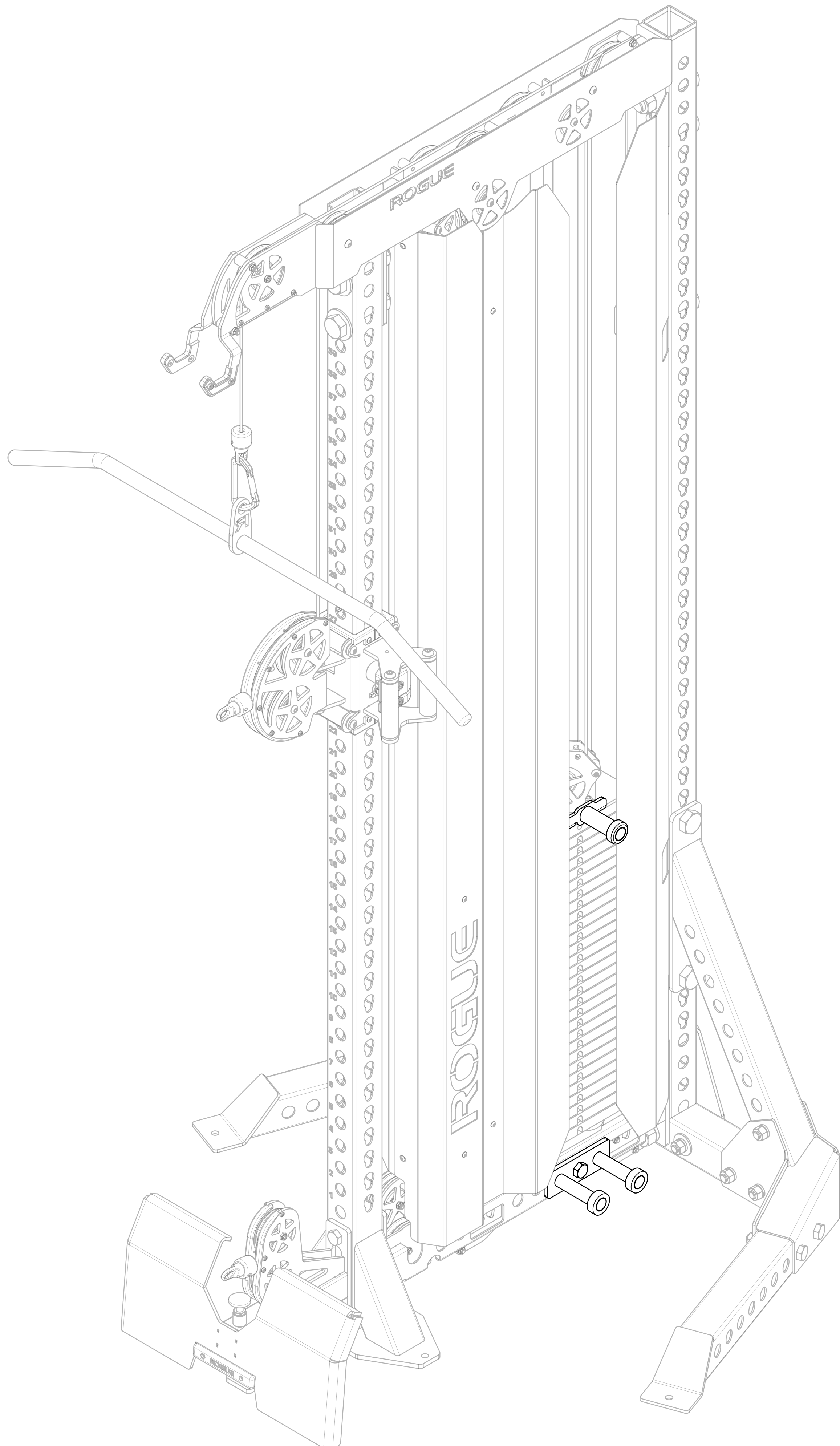

⚠ IMPORTANT SAFETY INFORMATION

DISCLAIMER:

Resistance training, gymnastics training, and activities at height are potentially dangerous and may lead to severe injury or even death. Use common sense when training, obtain instruction in the proper execution of movements, and understand your limitations. This equipment must only be used by competent and responsible persons. Obtaining instruction in appropriate techniques and methods of use is your own responsibility. You assume all risks and responsibilities for all damage, injury or death which may occur during or following incorrect use of this equipment in any matter whatsoever. Rogue Fitness bears no liability beyond the replacement value of the equipment in question.

WARNING:

MISUSE OF THIS PRODUCT CAN RESULT IN SEVERE INJURY. Both Rogue Fitness and buyer disclaim any express or implied warranty, including, without limitation, warranties or merchantability and/or fitness for a particular purpose with respect to the equipment. Buyer assumes all liability to use of equipment.

INCLUDED PARTS

Note: Images not shown at scale

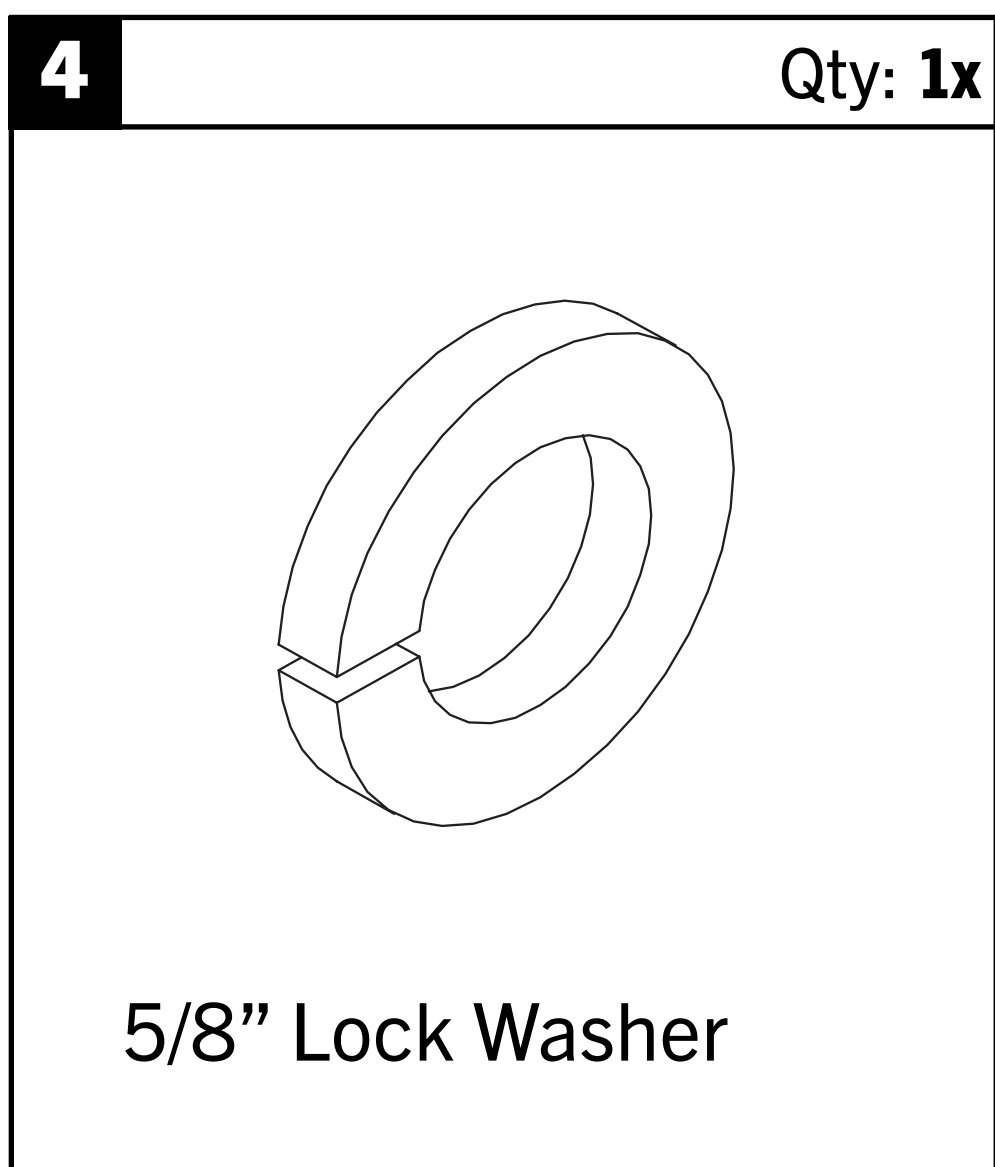
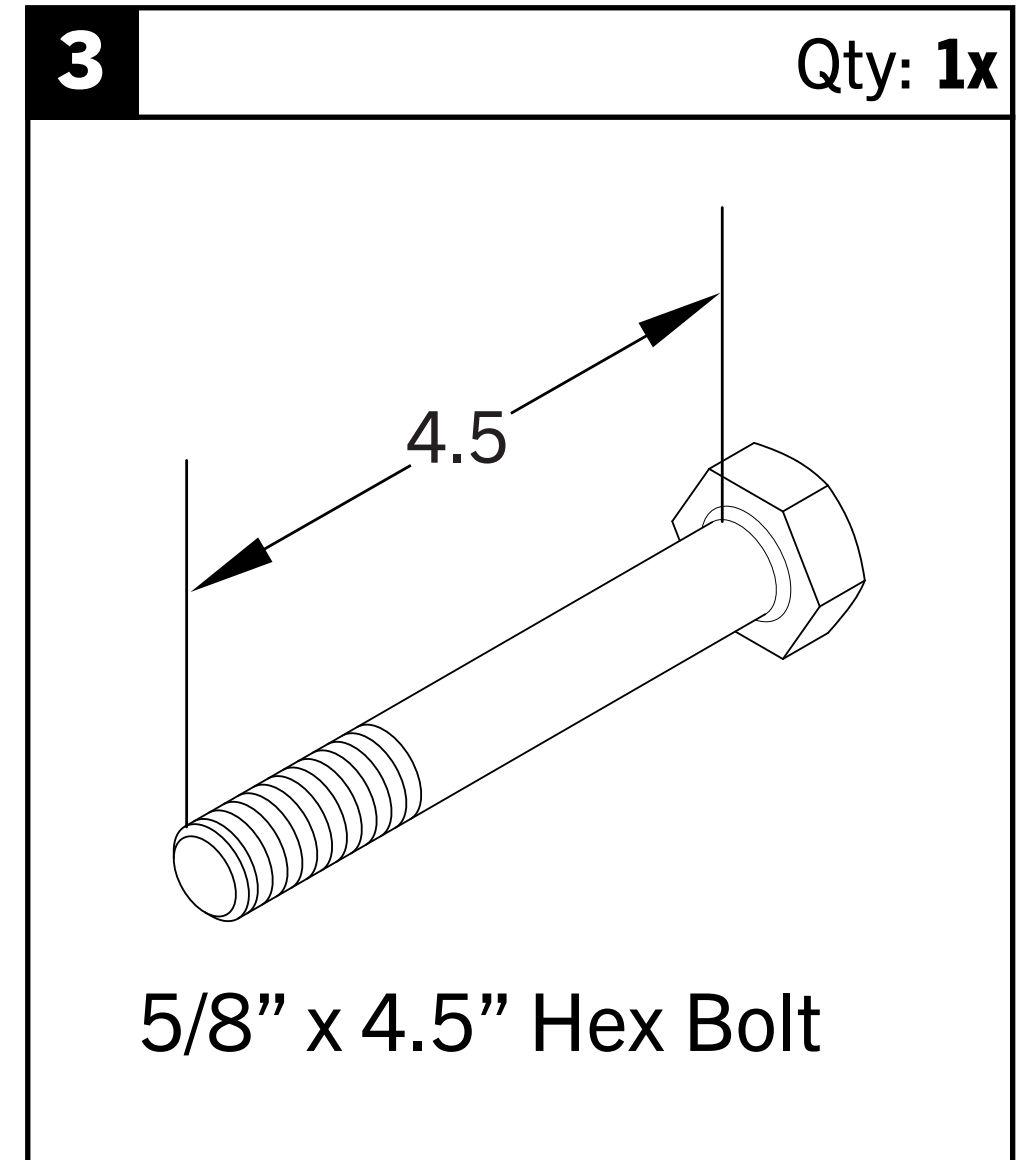
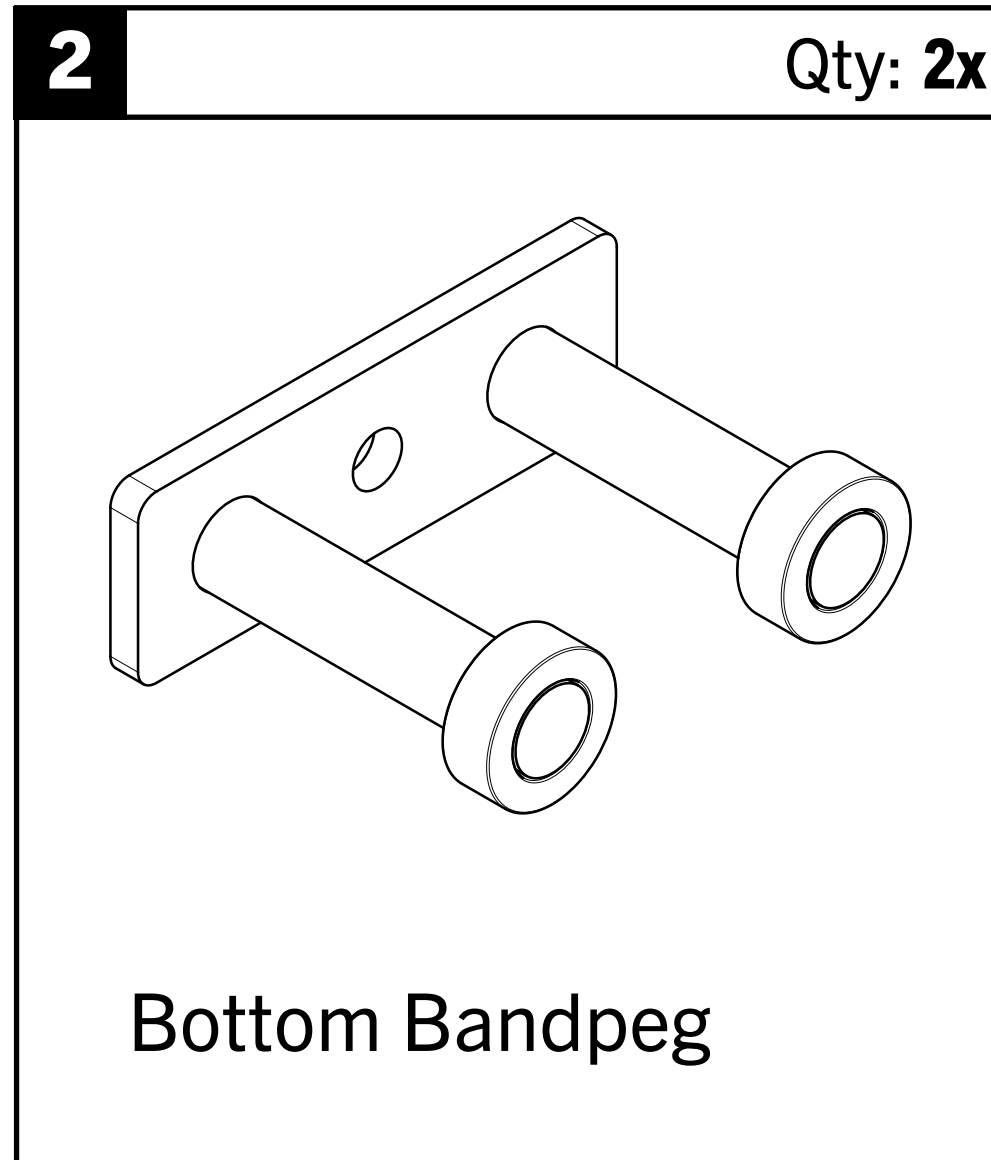
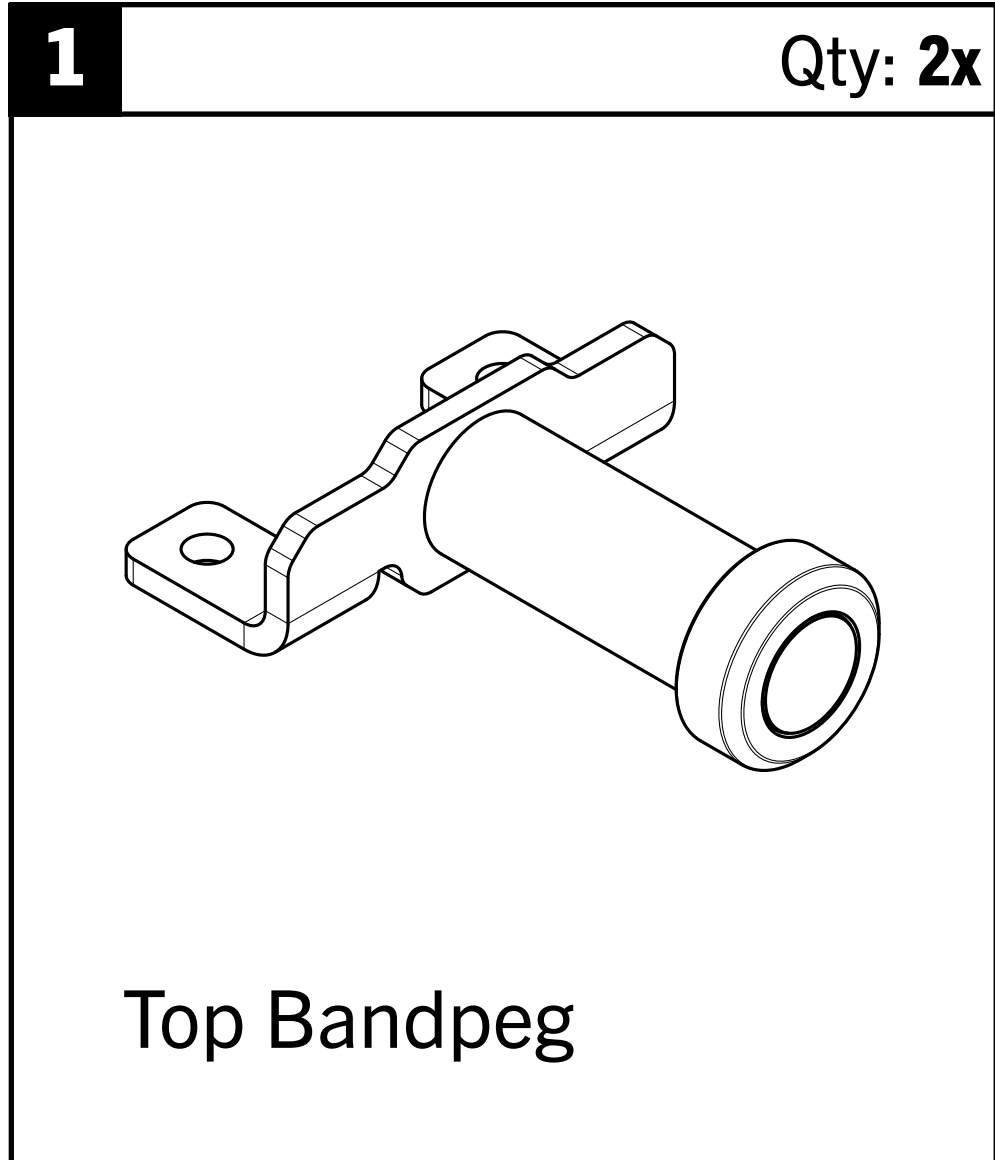

STEP 1

- To install Top Band Pegs [1], remove hardware from Weight Stack Stem shown in 1-A.
- Install Top Band Pegs [1] using hardware removed in step 1-A.
- If installing Top Band Pegs on existing CTM-1 Tower, lift Weight Stack and place weight stack selector in hole to create space for assembly.

- Attach Bottom Band Peg [2] to CTM Bottom Crossmember using 5/8" x 4.5" Hex Bolt [3], 5/8" Lock Washer [4], and 5/8" Hex Nut [5].

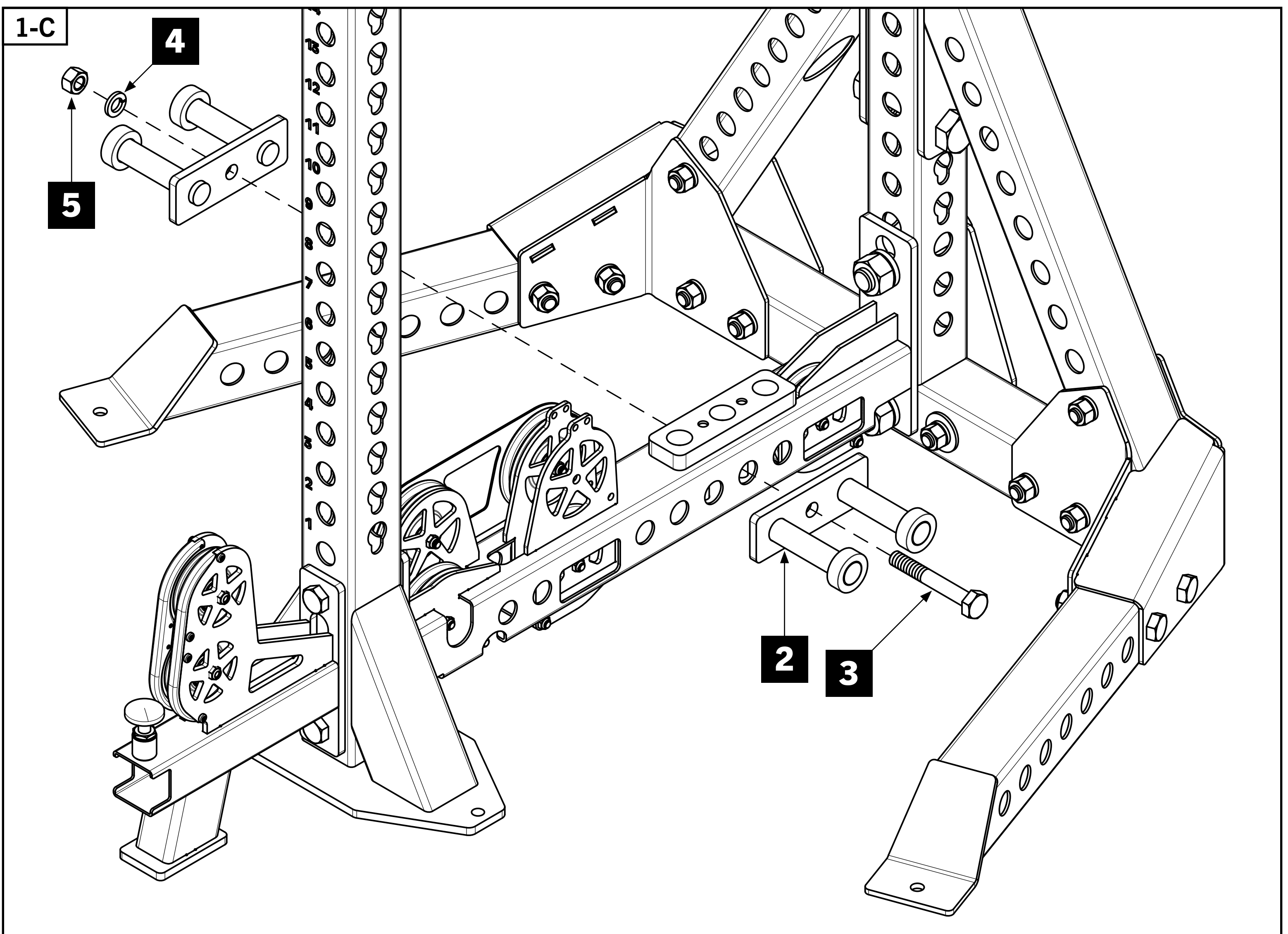
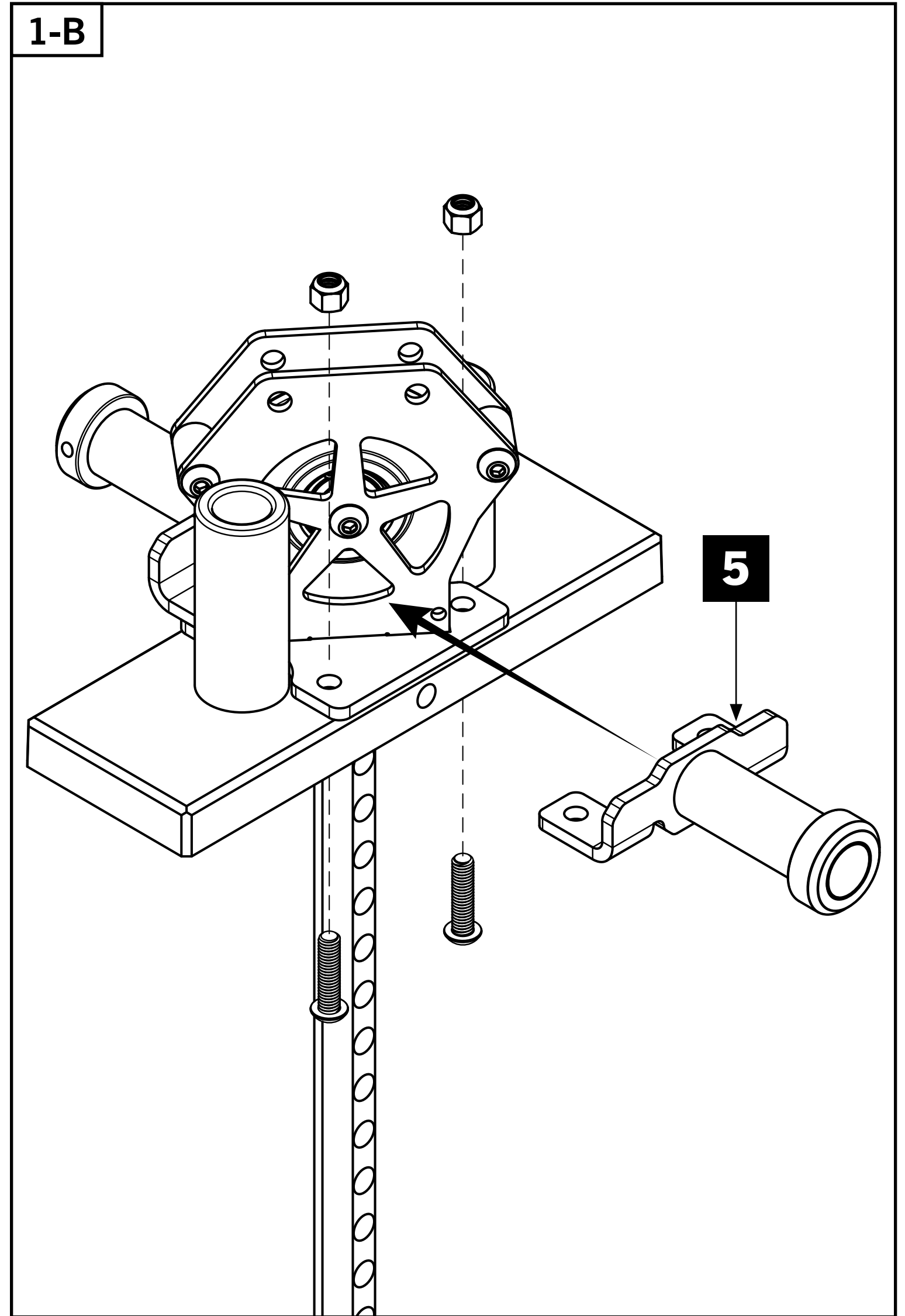
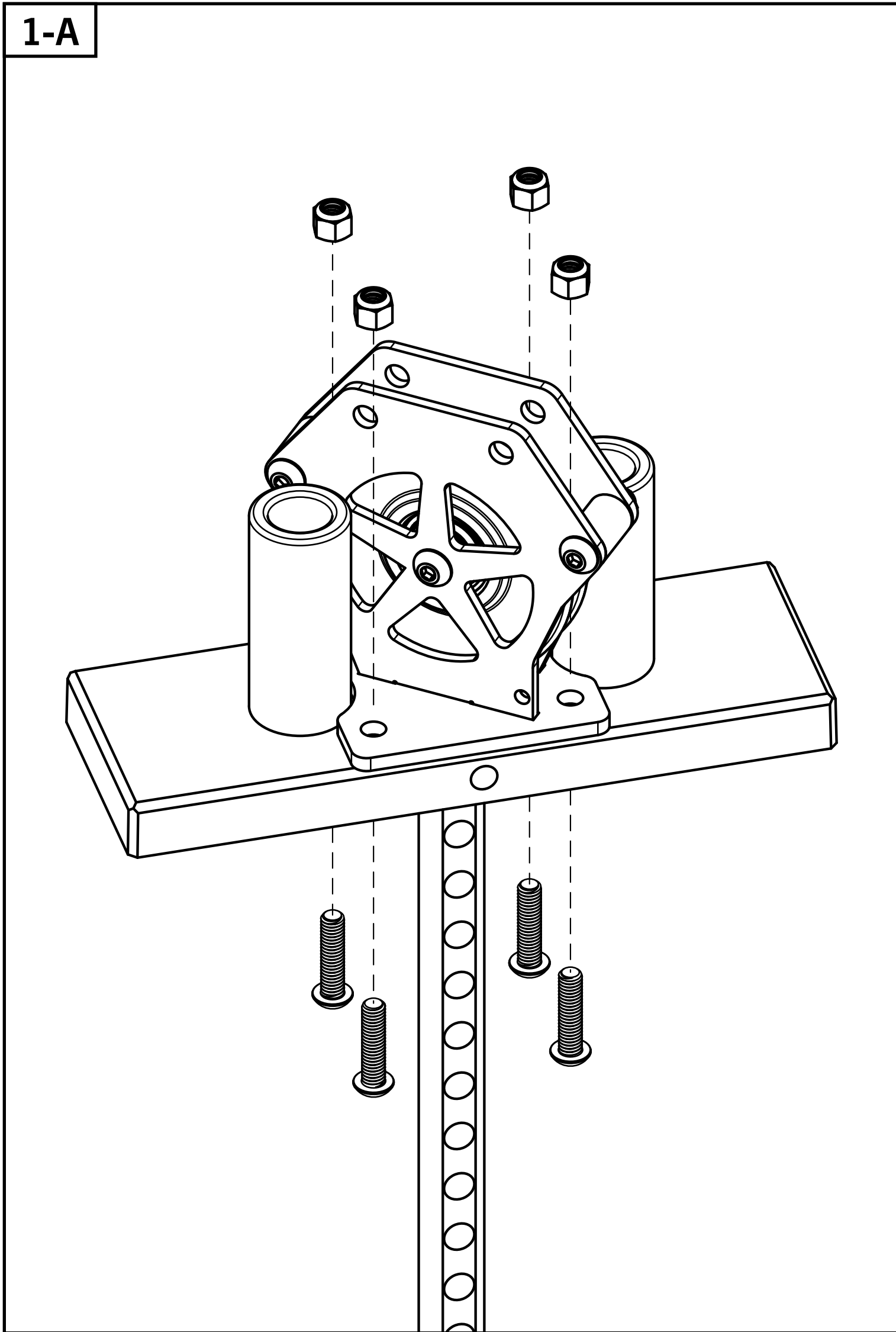

ROGUE



**SCAN FOR
INSTRUCTIONS**



**IRON GAME
PROGRAMMING**