

ROGUE®

ECHO WEIGHT VEST

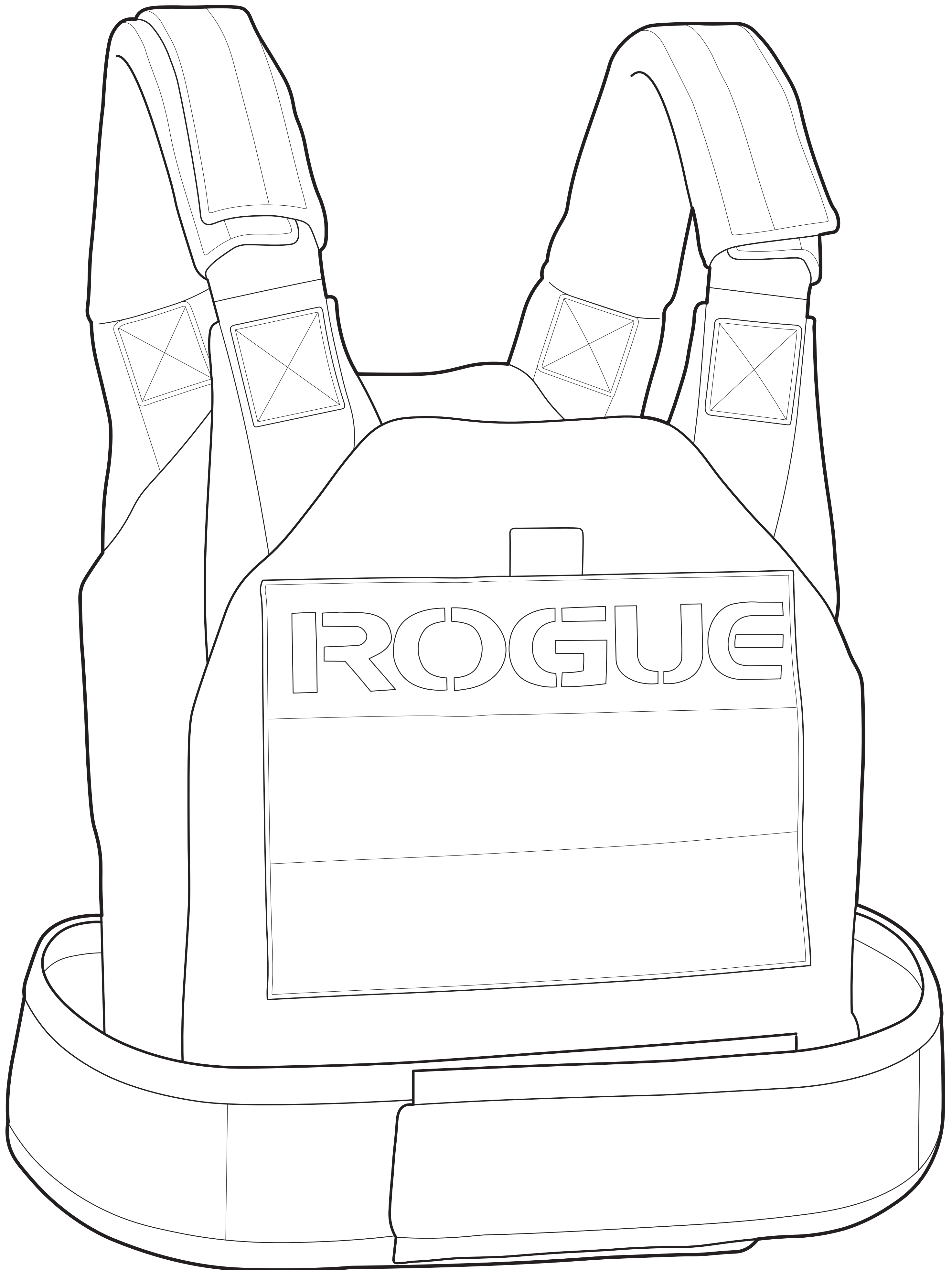

⚠ IMPORTANT SAFETY INFORMATION

DISCLAIMER:

Resistance training, gymnastics training, and activities at height are potentially dangerous and may lead to severe injury or even death. Use common sense when training, obtain instruction in the proper execution of movements, and understand your limitations. This equipment must only be used by competent and responsible persons. Obtaining instruction in appropriate techniques and methods of use is your own responsibility. You assume all risks and responsibilities for all damage, injury or death which may occur during or following incorrect use of this equipment in any matter whatsoever. Rogue Fitness bears no liability beyond the replacement value of the equipment in question.

WARNING:

MISUSE OF THIS PRODUCT CAN RESULT IN SEVERE INJURY.

Both Rogue Fitness and buyer disclaim any express or implied warranty, including, without limitation, warranties or merchantability and/or fitness for a particular purpose with respect to the equipment. Buyer assumes all liability to use of equipment.

IMPORTANT:

The Rogue Echo Weight Vest is intended strictly as a fitness accessory and should NEVER be used as body armor.

INCLUDED PARTS

Note: Images not shown at scale

1 Qty: **1x**

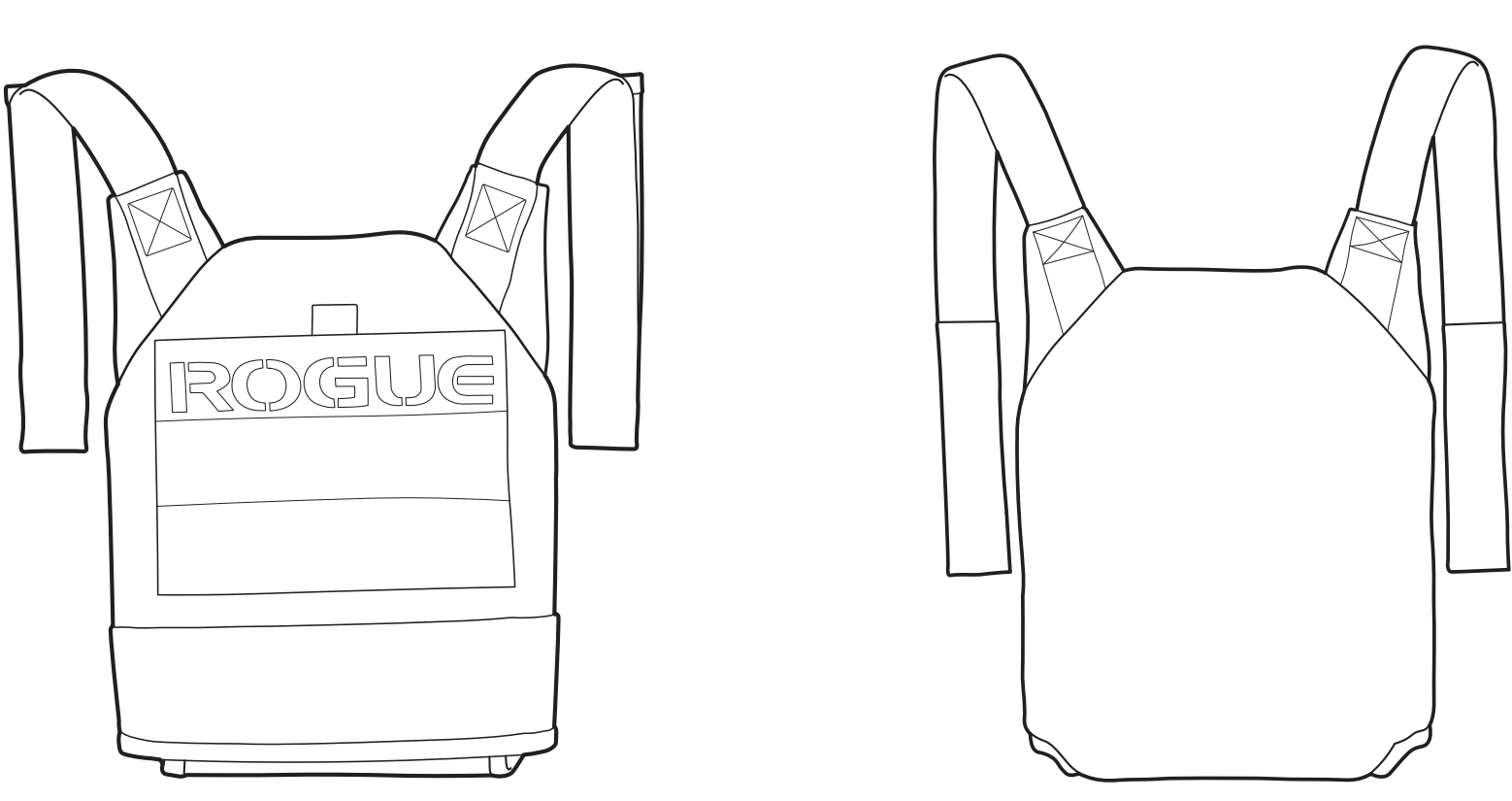

Front Panel (Exterior) Front Panel (Interior)

The exterior view shows a rectangular panel with a central pocket labeled 'ROGUE' and two shoulder straps with buckles. The interior view shows the reverse side of the panel with two shoulder straps and a central attachment point.

2 (Sold Separately) Qty: **2x**

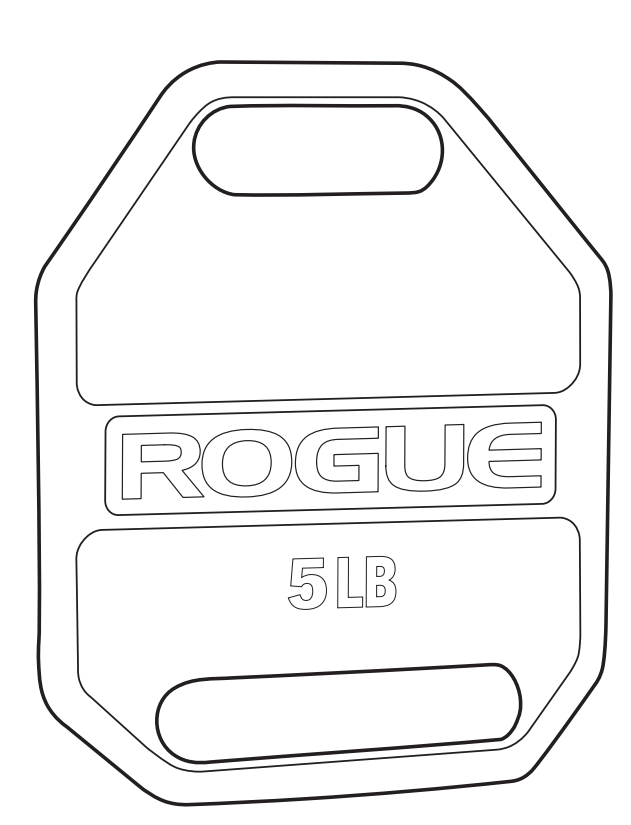

Weight Vest Plate

The weight vest plate is a rectangular plate with rounded corners, featuring a central pocket labeled 'ROGUE' and '5LB' and two horizontal slots at the top and bottom.

3 Qty: **1x**

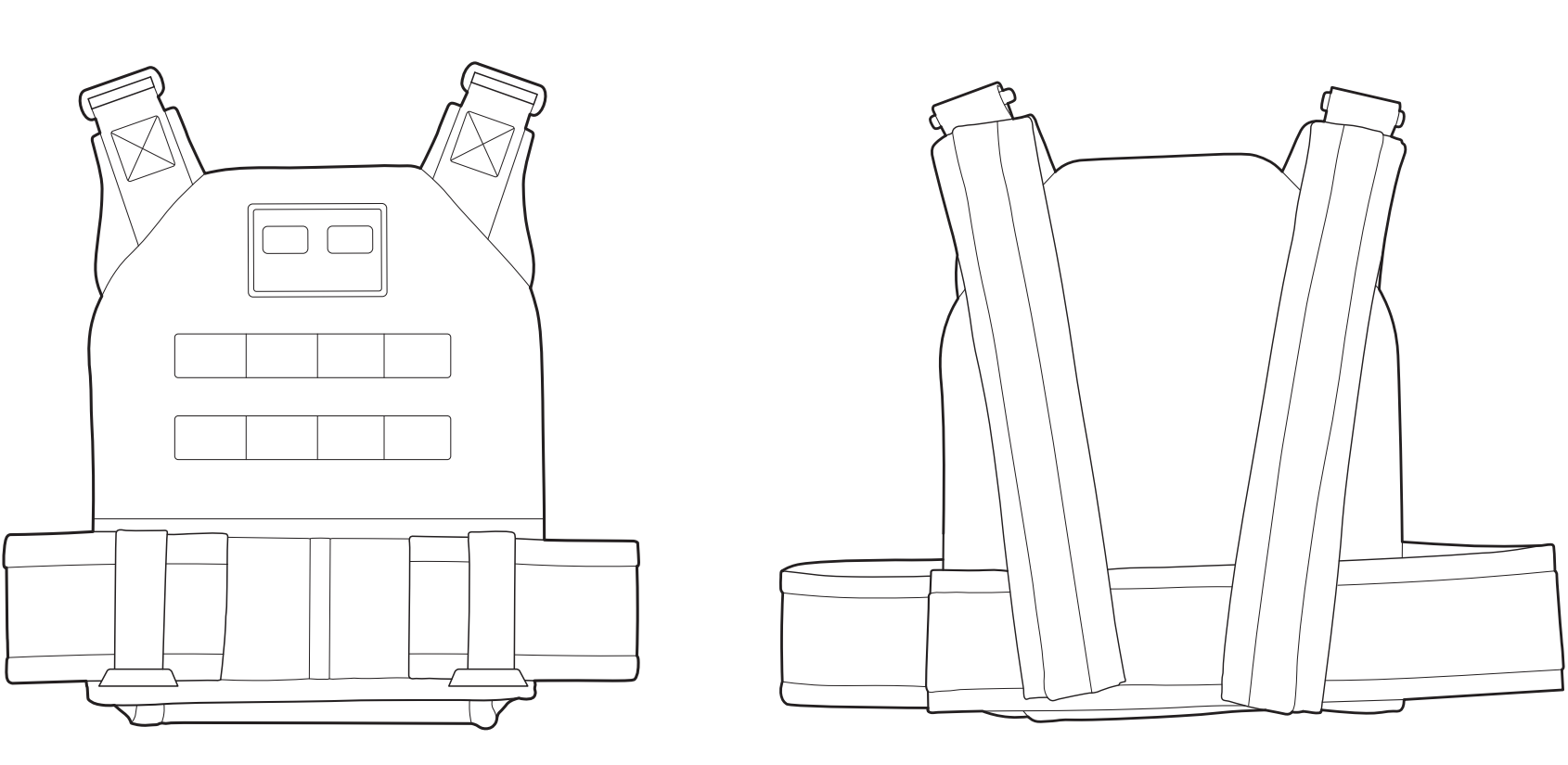

Back Panel (Exterior) Back Panel (Interior)

The exterior view shows a rectangular panel with a central pocket, two horizontal slots, and two shoulder straps with buckles. The interior view shows the reverse side of the panel with two shoulder straps and a central attachment point.

STEP 1

- **Important:** This product is strictly a fitness accessory and should **NEVER** be used as body armor.
- Position the Back Panel [3] interior side-up and the Front Panel [1] exterior side-up, as shown in 1-A.
- Prepare Shoulder Pads attached to the Back Panel [3]:
 - Separate the Velcro, as shown in 1-A.
- Guide Front Panel [1] shoulder strap through corresponding loop on Back Panel [3] and adjust to desired length before securing, as shown in **DETAIL**.

- Wrap the opened Shoulder Pad flaps around the strap and press Velcro together to prevent slipping, as shown in **DETAIL**.
- Repeat this process for the opposite side.
- Wrap waist belt attached to the Back Panel [3] around and fasten securely to the Front Panel [1] as shown in 1-B.
- **See VEST FIT for ideal sizing and vest positioning.**

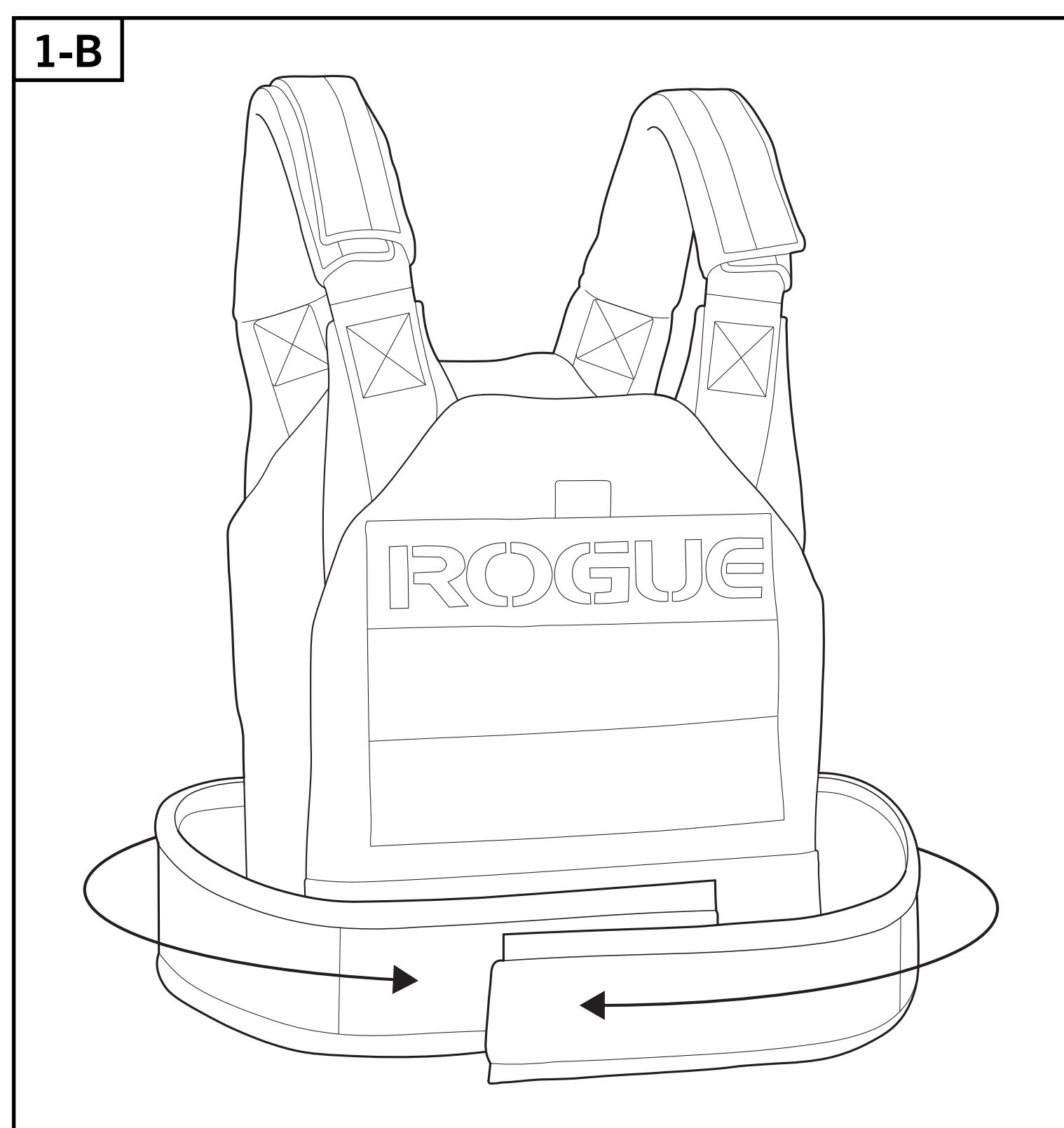
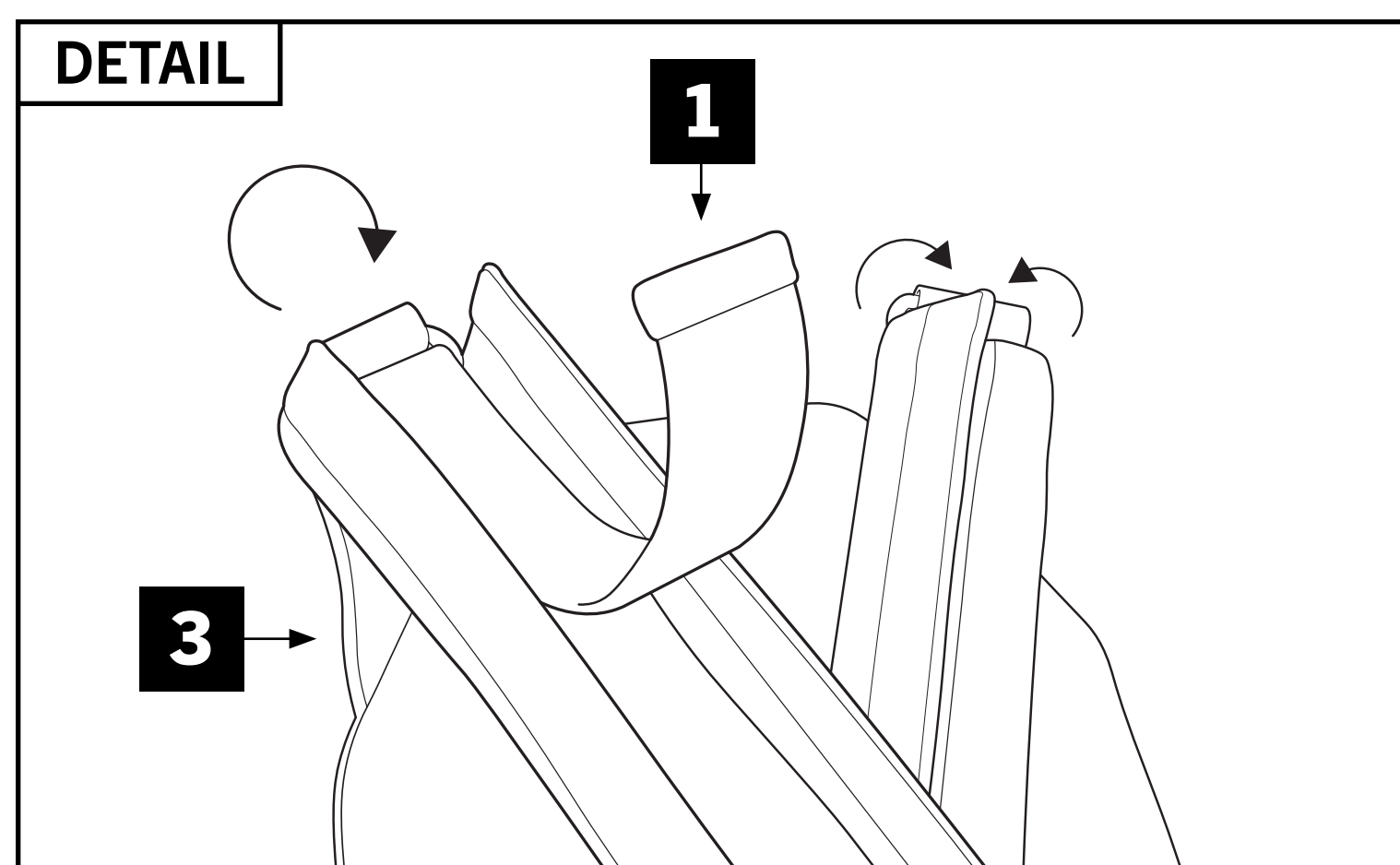
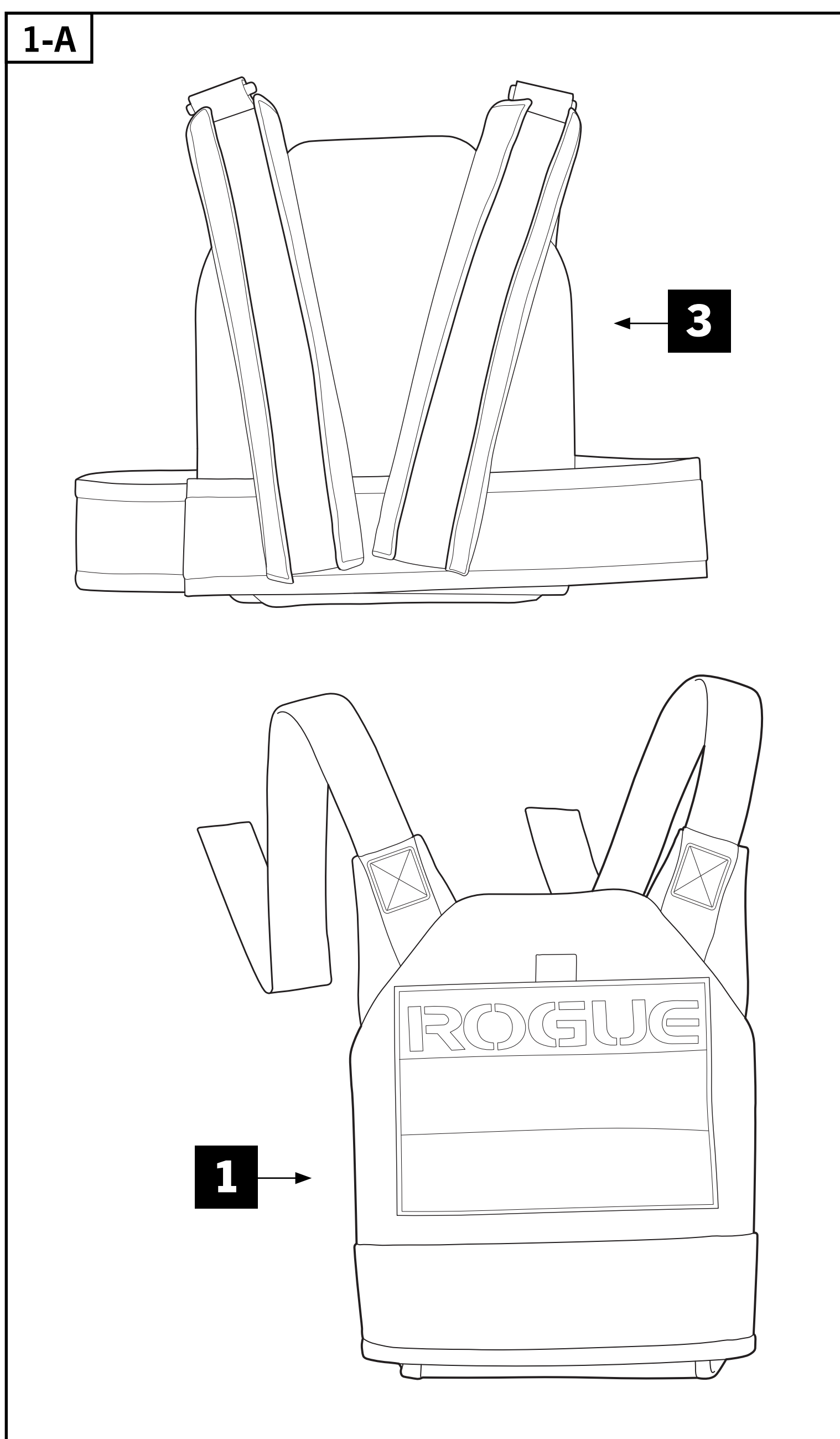

VEST FIT

Vest should sit securely and evenly across the torso, with the top of the front panel (B) approximately 1"-3" below the sternal notch (A), as shown. See **DETAIL** in **STEP 1** for shoulder strap adjustment instructions.

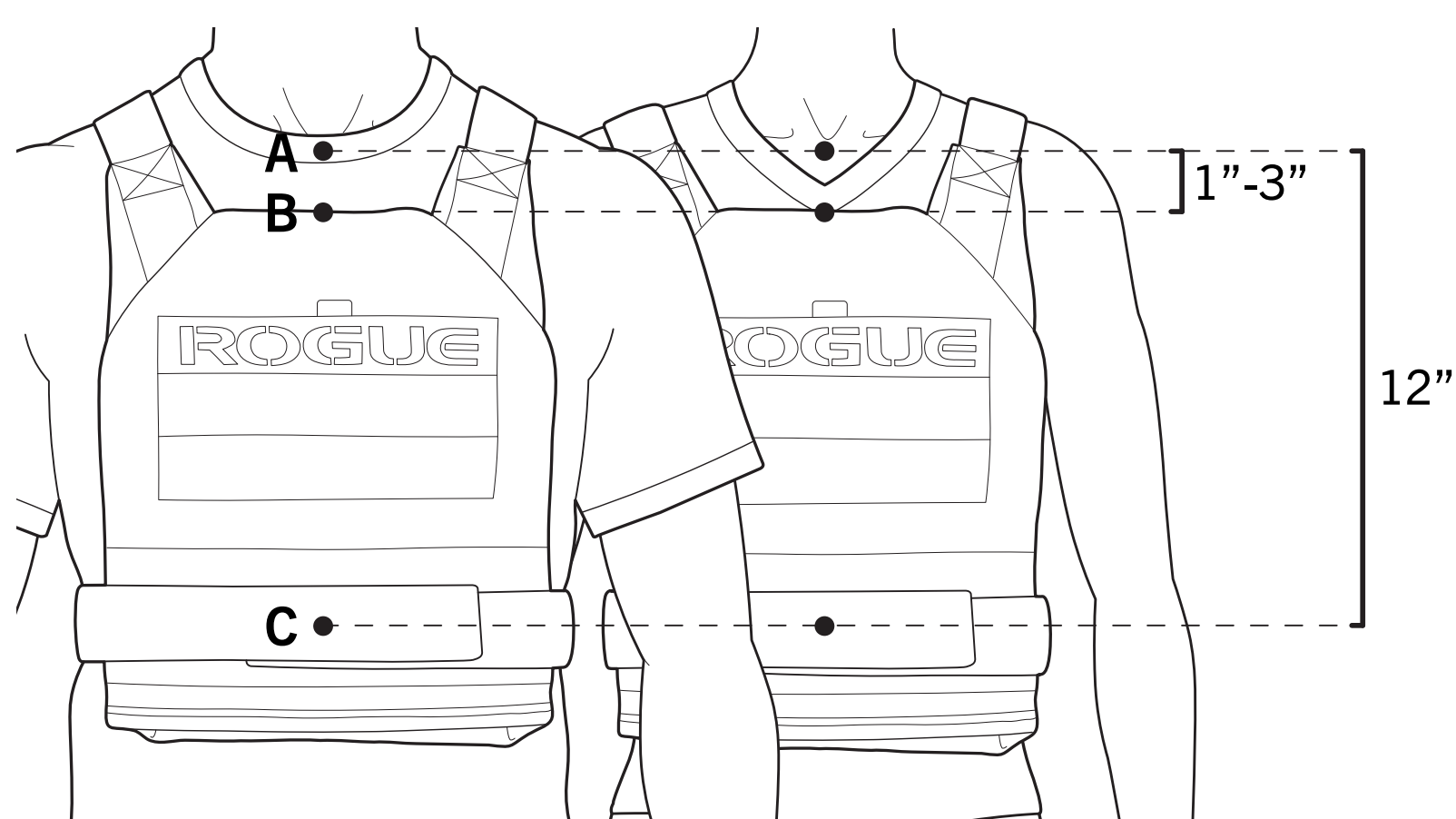

Size	Torso (C)	Shoulder Strap Max Length
S	25" - 34"	16"
M	34" - 42"	18"
L	42" - 50"	21"

To determine vest size, measure around the torso (C) 12" below the sternal notch (A).

STEP 2

- **Important: Weight Vest Plates SOLD SEPARATELY.** This product is compatible with Rogue Echo Weight Vest Plates and Rogue USA Cast Weight Vest Plates **ONLY**.
- Undo Front Panel [1] Velcro closure.
- Fully extend internal strap, as shown in **DETAIL 1**, and secure together with the hook, creating a loop.
- Hold the looped straps **ABOVE** the Weight Vest Plate [2] before sliding inside, as shown in **2-A**.
- Undo the hook and run strap through and around the handle at the end of the Weight Vest Plate [2] before reconnecting, as shown in **DETAIL 2**.
- Push Weight Vest Plate [2] to the top seam of the carrier.
- Tighten the strap with medium pressure to avoid puckering at the seam and tuck Velcro flap into carrier, as shown in **2-B**.
- **See PLATE FIT for additional instruction on proper tucking method and fit details.**
- Smooth out Velcro closure and secure tight with firm pressure.
- Repeat process for the Back Panel [3] as needed.

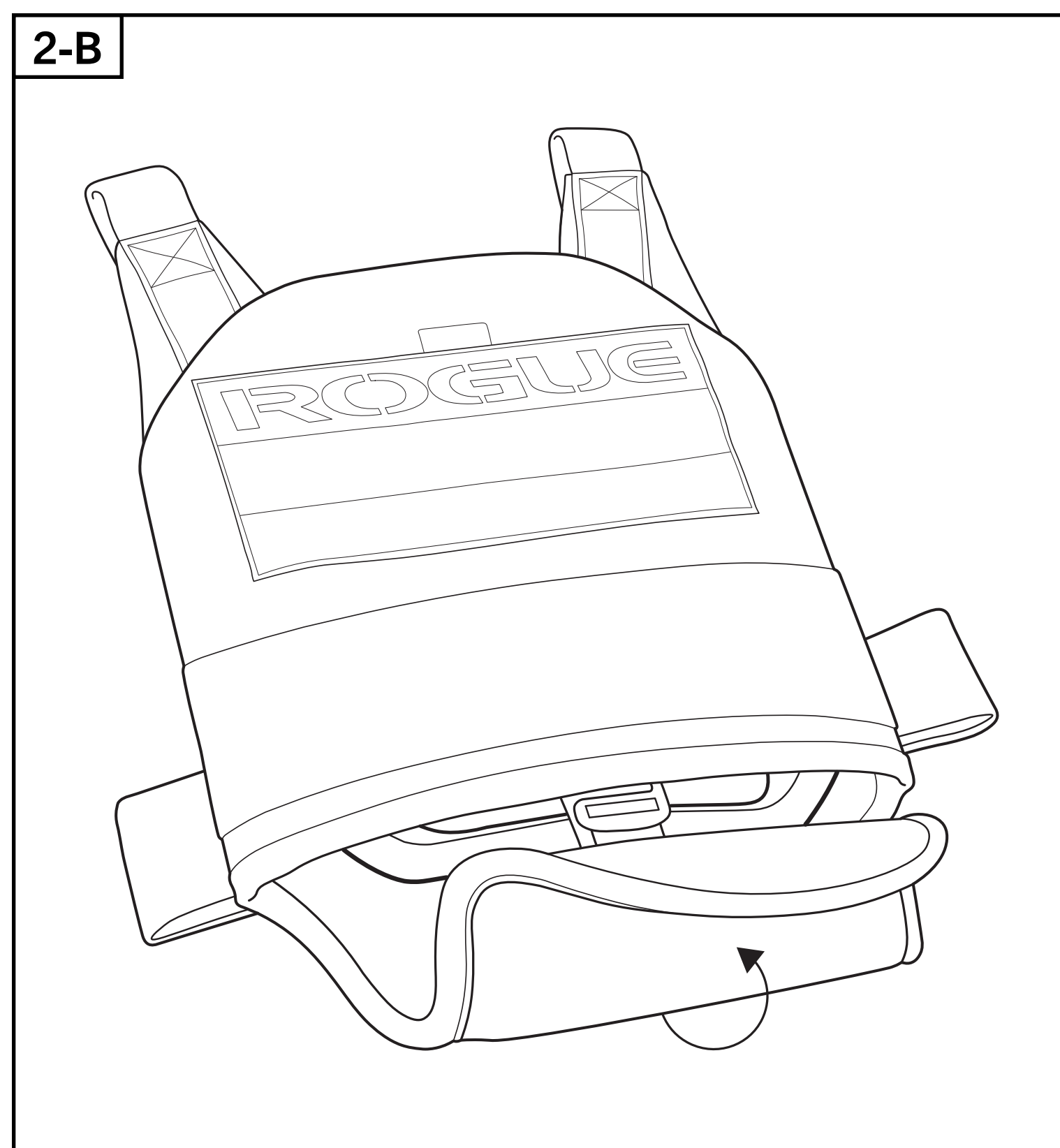
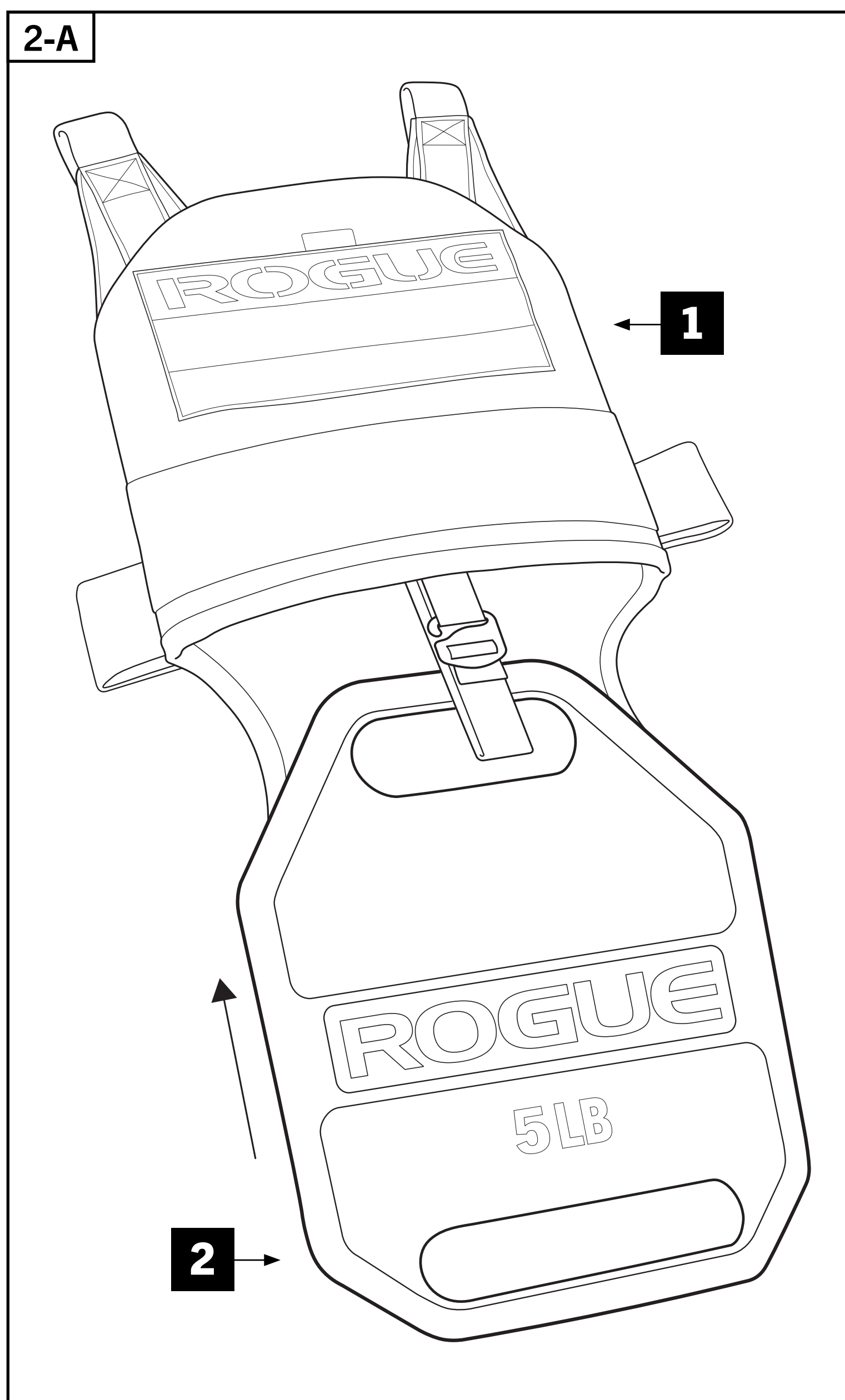
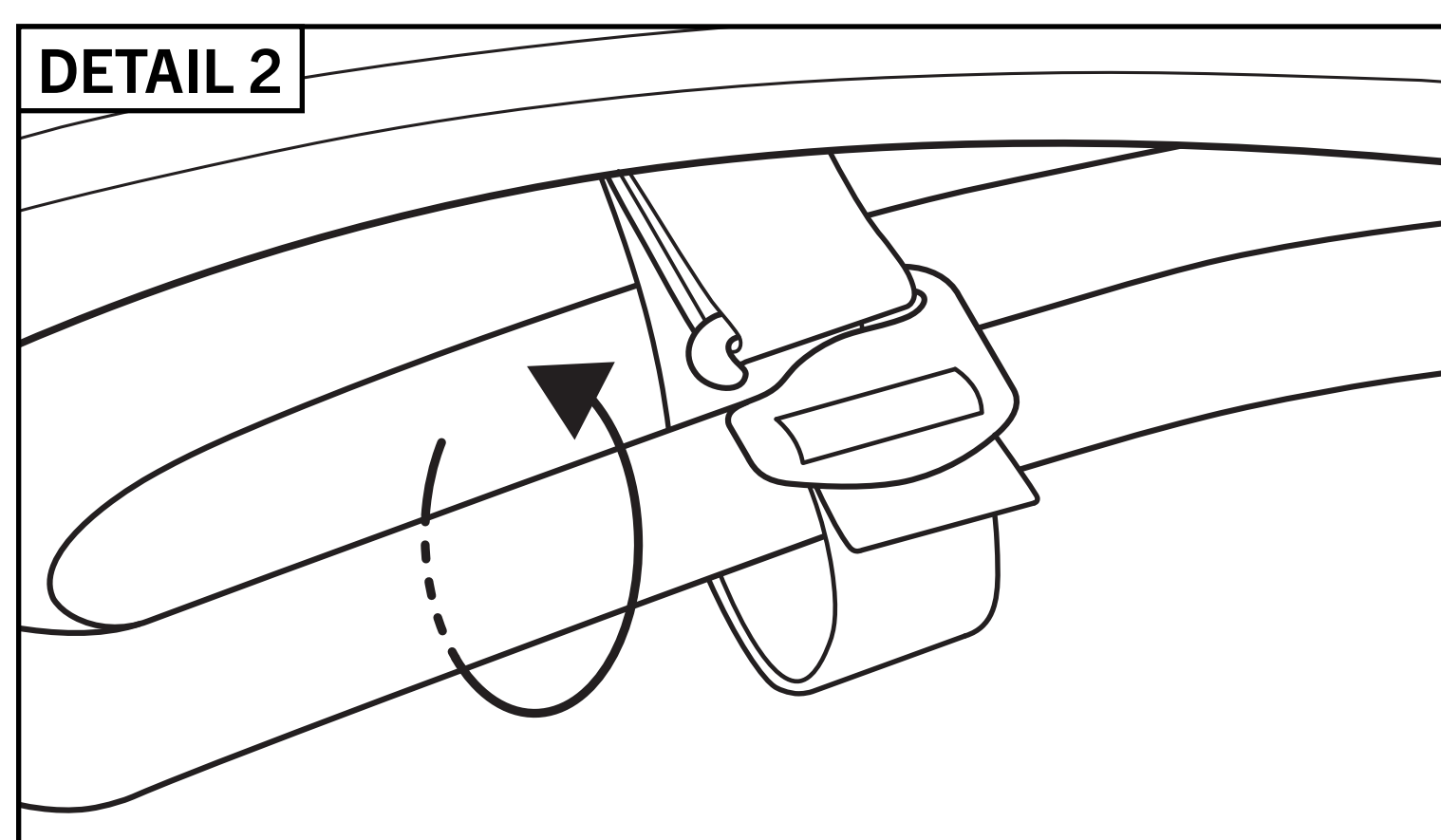
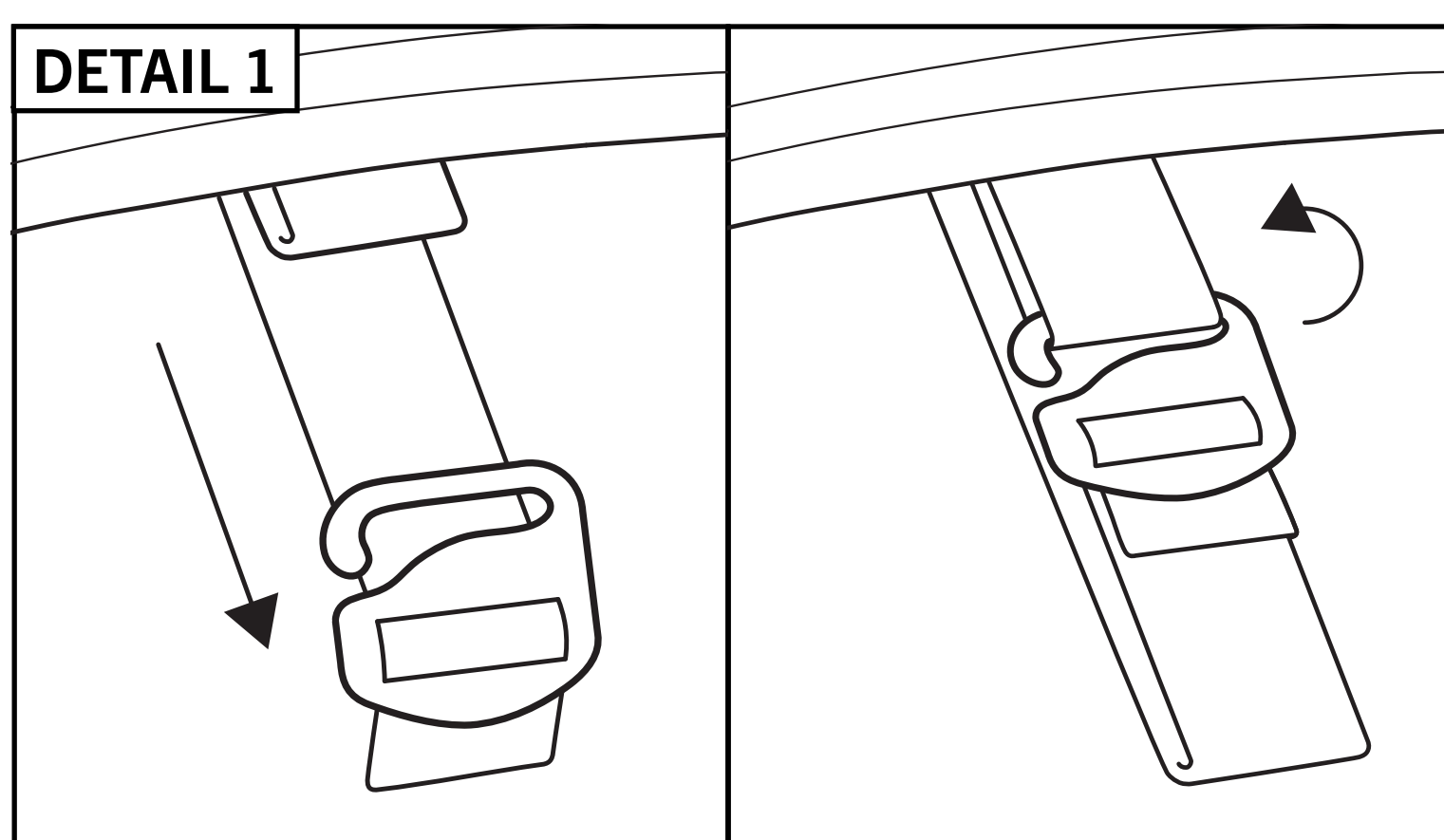
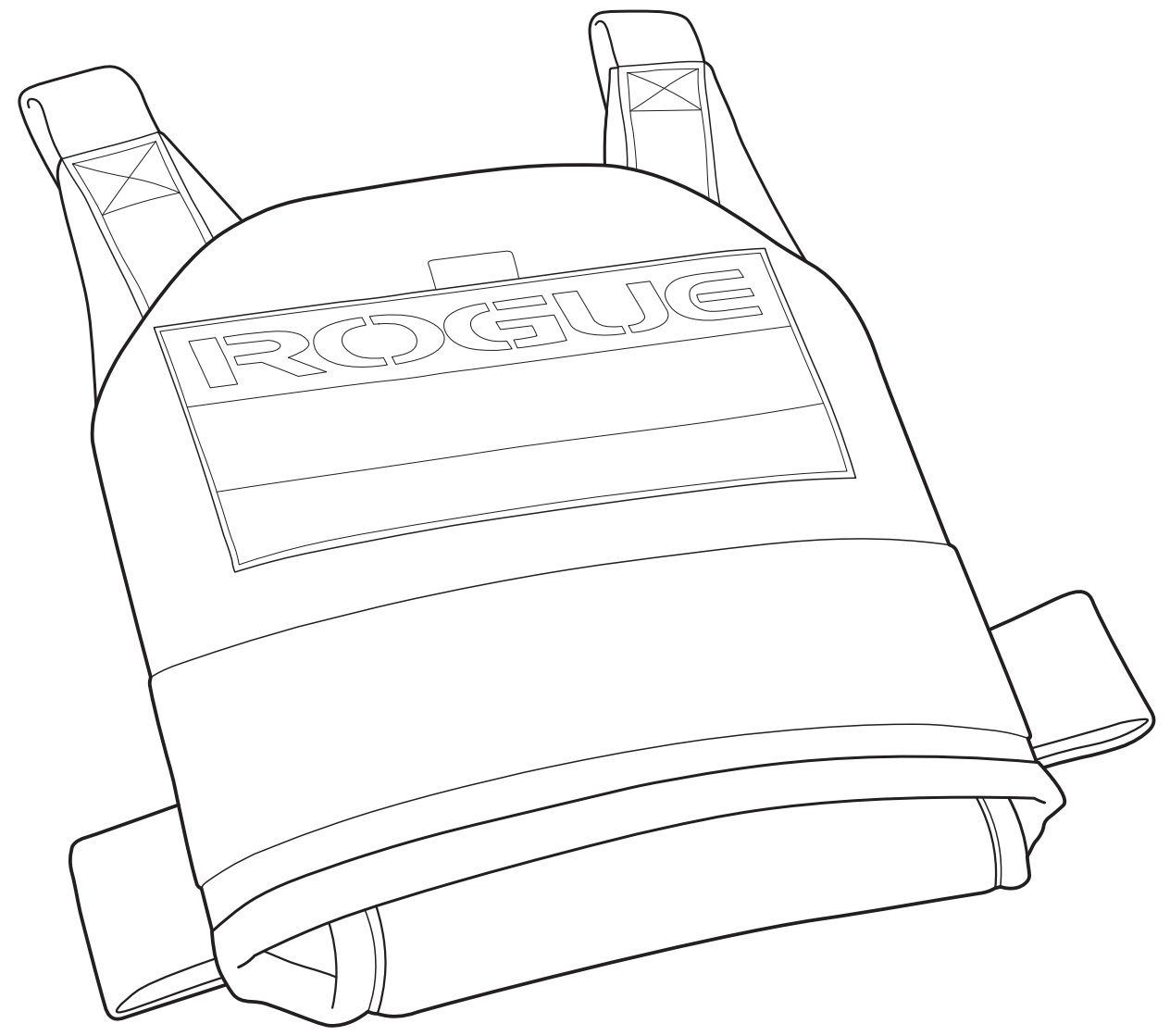
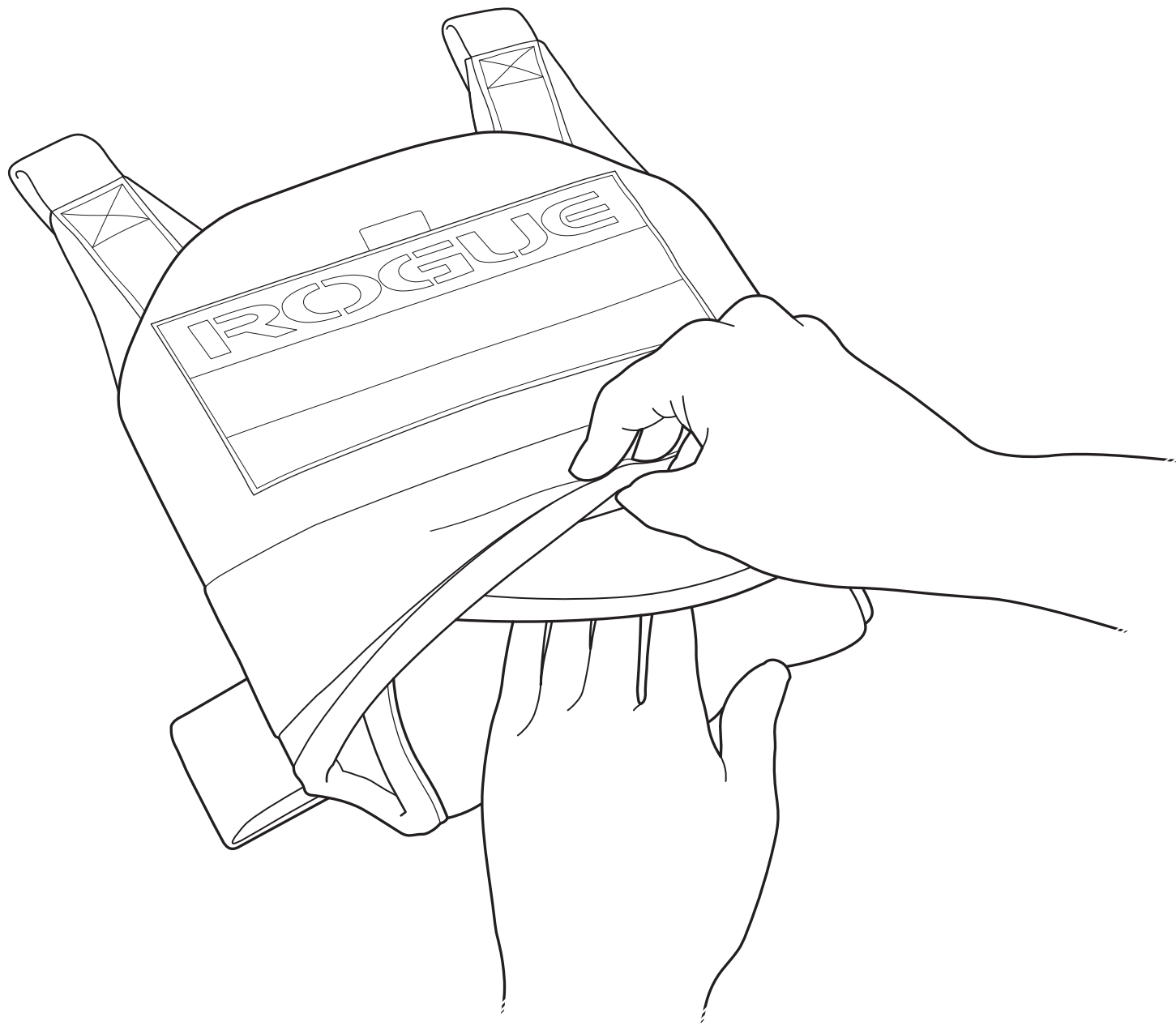
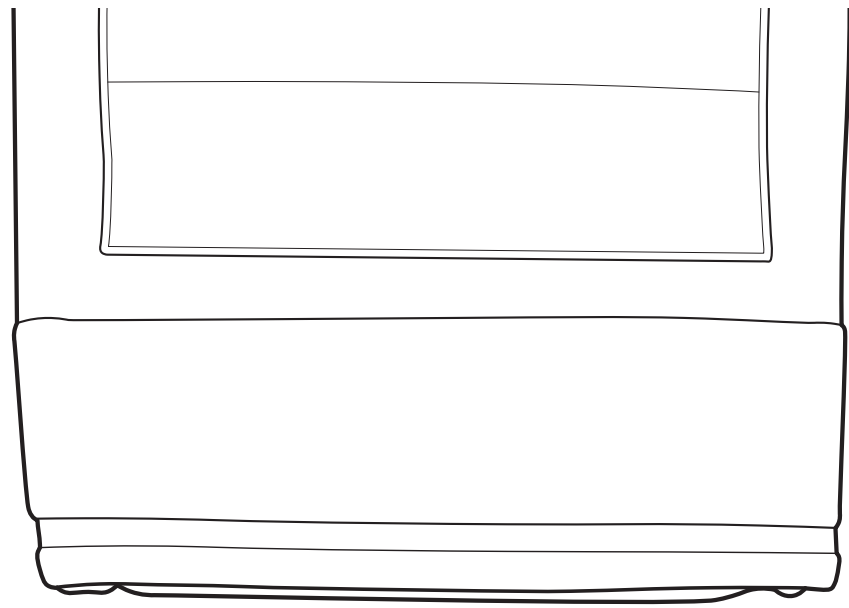

PLATE FIT

Plate fit may vary slightly depending on the size and thickness of the vest plates used. To properly secure the flap, fold it inward before inserting it into the carrier, then allow it to unfold flat against the plate, as shown below.



Larger plates can cause the securing flap to extend farther due to the added material inside the carrier, as shown below. As long as the internal strap is correctly routed through the plate, the flap is fully closed, and the Velcro is properly fastened, the plate will remain secure during training.



5LB/2.5KG PLATES

The Rogue 5LB Vest Plate sits fully inside the carrier and remains above the bottom hem when properly secured.

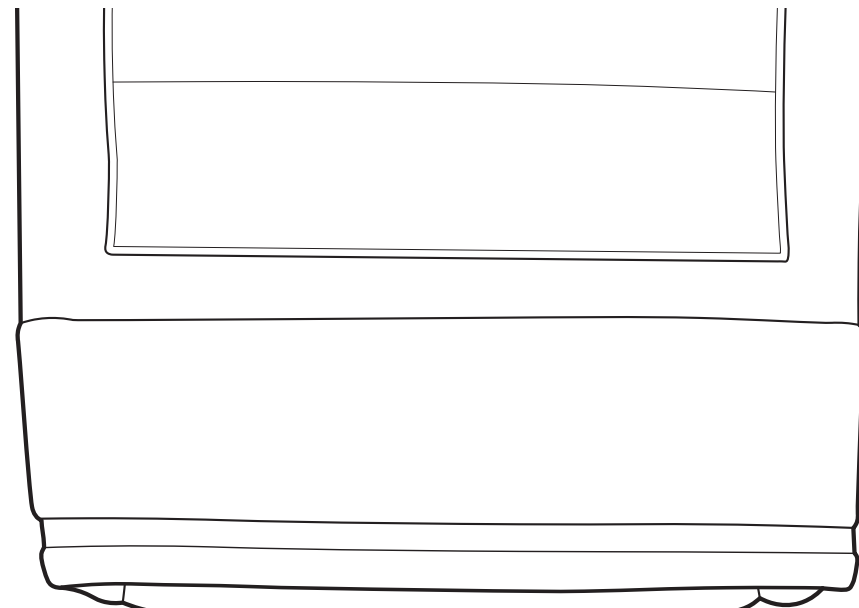

10LB/5KG PLATES

The Rogue 10LB Vest Plate sits flush with, or may extend slightly below, the bottom hem of the vest when fully secured.

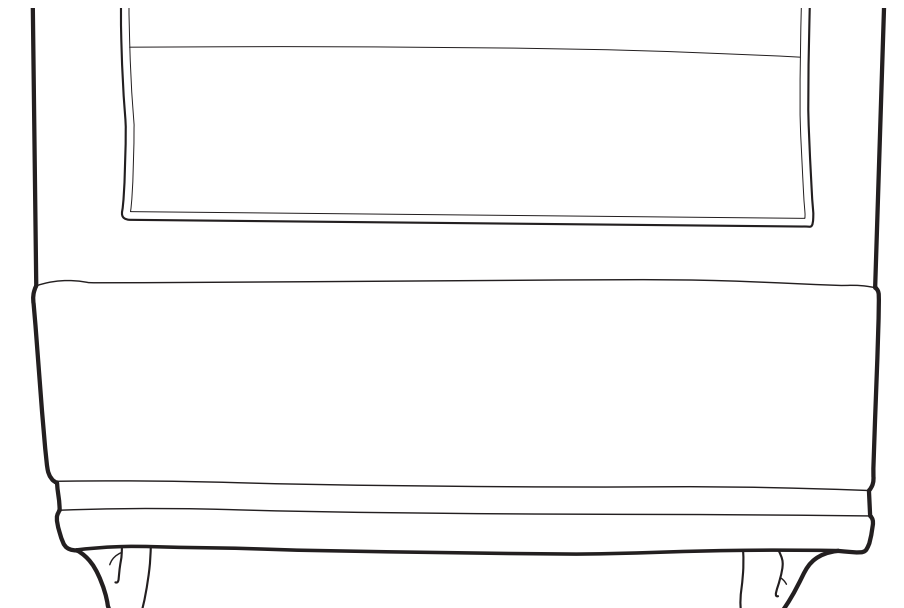

20LB/10KG PLATES

The Rogue 20LB Vest Plate extends approximately 3/4" below the bottom hem of the vest when properly secured.

ROGUE



**SCAN FOR
INSTRUCTIONS**



**IRON GAME
PROGRAMMING**